

# SIRUBA

電控參數說明書

ELECTRONIC CONTROL PARAMETER MANUAL

■700K(BKF)/CE



# 目錄 Content

I. 安裝與調整 / Installation and Adjustment .....	1
II. 縫製畫面 / Sewing screen .....	3
III. 編程畫面 / Programming screen .....	7
IV. 參數設定畫面 / Parameter setting screen .....	11
V. 鬆線緊度調整畫面 / Elastic adjustment screen.....	19
VI. 裝置測試畫面 / Solenoid valve test screen.....	21
VII. 控制箱說明 / Description of the control box .....	24
VIII. 光檢知器靈敏度調整 / Sensor sensitivity adjustment .....	26
IX. 錯誤代碼 / Error Code list .....	27

# I. 安裝與調整 / Installation and Adjustment

(1).馬達的安裝：請參閱各車頭製造廠之說明書。

**Motor installation:** Please refer to the machine head's instruction.

(2).控制箱的安裝：

## Control Box Installation:

a).車板右側面須預留 100 mm 以上空間  
Leave 100 mm space at right

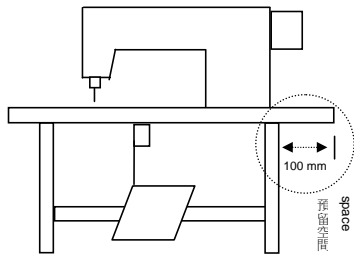

b).將 i70L 制箱鎖裝於車板下方  
Mounting i70L Under the working table

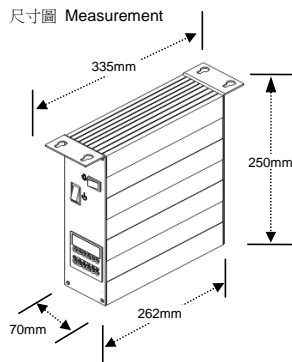

c).安裝後示意圖  
Installation layout

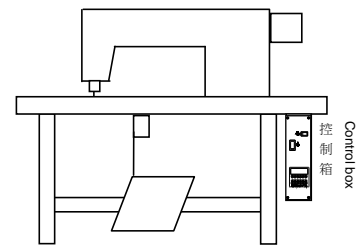

(3).控速器的安裝：

## Speed Control Unit Installation:

a).控速器與其支架座  
Speed Control Unit

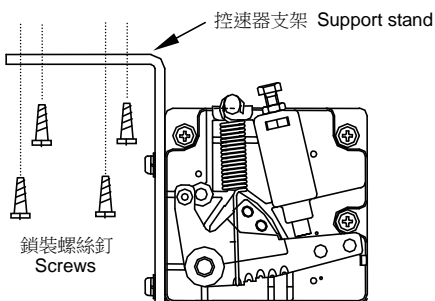

鎖裝螺絲釘時，需以螺絲起子全程鎖裝。

Always use screwdriver to tightly secure screws

b).保持在吊桿成直線下，將控速器連座鎖於車板下方  
Keep rod in vertical, secure the unit under the table

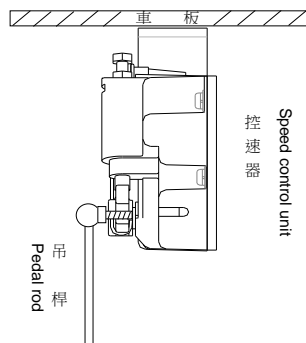

c).安裝後示意圖  
Installation layout

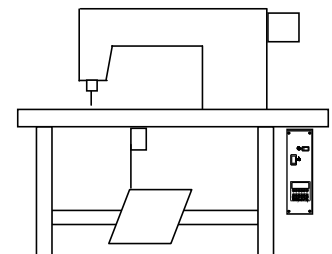

(4).控速器前/後踏力量的調整：

## Adjust the speed control unit:

控速器各部位名稱：如右圖示

Components of the speed control unit: see figure

- A: 前踏力量彈簧 / Spring for toeing forward force adjustment
- B: 後踏力量的調整螺栓 / Bolt for heeling backward force adjustment
- C: 踏板旋臂 / Treadle / Pedal arm
- D: 腳踏板吊桿 / Pitman Rod for Treadle / Pedal

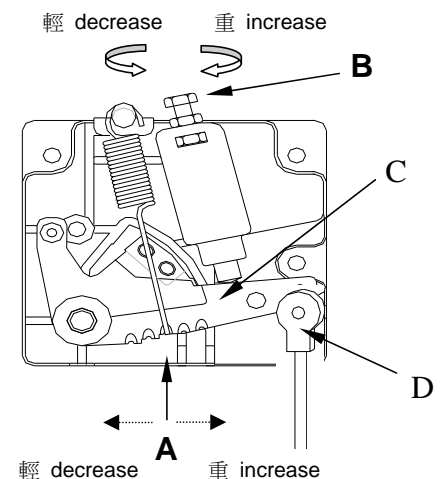

調整需求 Term of adjustment		調整結果 Adjustment result
1	踏板前踏力量的調整 Toeing forward force adjustment	當彈簧 A 愈向右側勾時，表示力量愈重。 Spring A move to right = force increased. 當彈簧 A 愈向左側勾時，表示力量愈輕。 Spring A move to left = force decreased.
2	踏板後踏力量的調整 Heeling backward force adjustment	當螺栓 B 愈向上↶時，則後踏力量愈輕。 Bolt B turn ↶ = force decreased. 當螺栓 B 愈向下↷時，則後踏力量愈重。 Bolt B turn ↷ = force increased.
3	踏板行程長短的調整 Treadle stroke adjustment	當吊桿 D 向右側孔鎖裝時，表示行程較長。 Rod D secure at right = stroke is longer. 當吊桿 D 向左側孔鎖裝時，表示行程較短。 Rod D secure at left = stroke is shorter.

## II. 縫製畫面 / Sewing screen

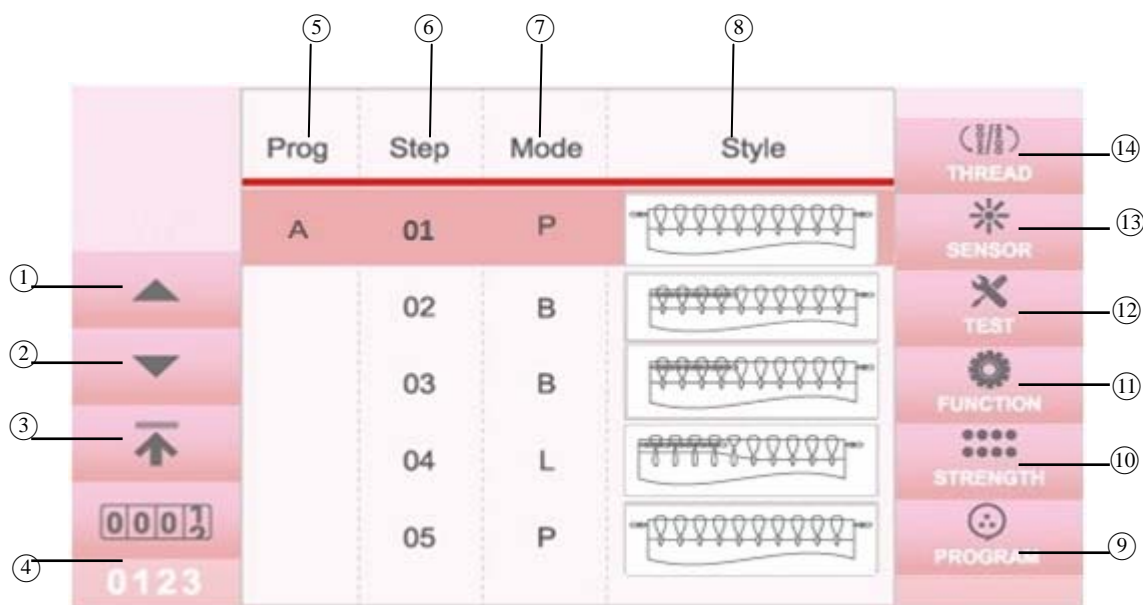

### ① 銀幕光棒上移鍵 / Shift upward

說明：每按一次上移鍵，光棒則返回上一階。

Description: To go to the previous step when press shift upward key.

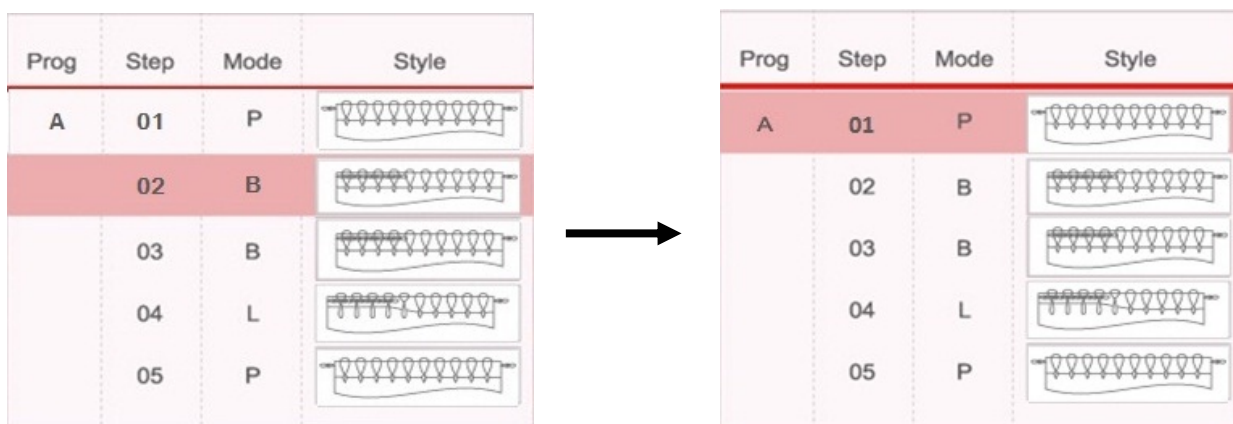

### 注意!

按此鍵，縫製模式由 Step 02 (B) 返回 Step 01 (P) 或者由 Step 05 (P) 返回 Step 04 (L) 時，必須在沒有布料的狀態下，踩下踏板或者按下空線鍵重置鍵 ，進行空線鍵重置動作。若縫製模式由 step4 (L) 返回 step3 (B) 時，不必進行空線鍵重置動作。

### CAUTION!

If the sewing mode returns to Step 01 (P) from Step 02 (B) or to Step 04 (L) from Step 05 (P) when press shift upward key, be sure to press the machine treadle once with no fabric under the sensor or press  thread key in order to proceed with the sewing operation. When the sewing mode returns to Step 03 (B) from Step 04 (L), there is no need to press treadle or the thread key.

②



銀幕光棒下移鍵 / Shift downward

說明：每按一次下移鍵，光棒則往下一階。

Description: To go to the next step when press shift downward key.

③



回到縫製模式 Step 01 / return to the first step

說明：按此鍵後會回到縫製模式 Step 01。

Description: Press key to return to the first step (sewing mode).

Prog	Step	Mode	Style
A	01	P	
	02	B	
	03	B	
	04	L	
	05	P	

→

Prog	Step	Mode	Style
A	01	P	
	02	B	
	03	B	
	04	L	
	05	P	

**注意!**

按此鍵 ，縫製模式將由 Step 03 (B) 返回 Sep 01 (P)，必須在沒有布料的狀態下，踩下踏板或者按下空線鍵重置鍵 ，進行空線鍵重置動作。

**CAUTION!**

If the operation type (sewing mode) changes by pressing key, be sure to press the machine treadle once with no fabric under the sensor or press thread key before starting a sewing operation.

④

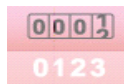

計數器 / Counter

說明：縫製物計數用，按此鍵 3 秒可重置計數器。

Description: fabric counting. Press the button 3 seconds to reset the counter.

⑤

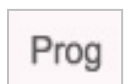

縫製工程 / Programs

說明：縫製工程,共 A~Z 26 個工程。

Description: the sewing programs, a total of 26 types (A~Z).

⑥



縫製段數 / Steps

說明：縫製段數, 共有 20 段。

Description: sewing number of step, a total of 20 steps.

⑦

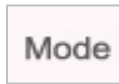

縫製模式 / Sewing mode

說明：顯示縫製模式,共有 9 種縫製模式(B、P、R、S、Bc、Pc、Rc、Sc、L)。

Description: displays a type of sewing mode, a total of 9 sewing modes(B、P、R、S、Bc、Pc、Rc、Sc、L).

⑧



縫製圖形 / Sewing patterns

說明：顯示各種縫製模式的圖形。

Description: all kinds of sewing patterns.

⑨



編程畫面 / Programming key

說明：按此鍵後進入到編程畫面。

Description: to enter sewing modes

⑩



鬆線緊度調整鍵 / Strength key

說明：按此鍵會切換到鬆線緊度調整畫面。

Description: to adjust the sewing performance after replacing the needle or threading the machine.

⑪



參數設定鍵 / Function key

說明：按此鍵會切換到參數設定畫面。

Description: press this key, it will switch to the parameter setting mode.

⑫



輸出裝置測試鍵 / Device test key

說明：按此鍵時會進入輸出裝置測試畫面。

Description: press key into the solenoid valve test screen.

⑬



布料檢知器 / Fabric detect sensor

說明：當有檢出到有布料時，由原先淡紅色變成深紅色。

Description: When sensor detected the fabric, the original light red changes to dark red.

⑭



空線鏈重置鍵 / Thread key

說明：執行空線鏈重置的動作。

Description: To perform a SET UP operation.

例1. 當工程 B (縫製模式為倒回縫 B) 變更為工程 A (縫製模式為基本縫 P) 時，夾線裝置還殘留著工程 B 的空線鏈。

When the kind of Prog is changed from B (its first step is backlatching) to A (its first step is plain seaming), the thread chains is still remaining in the clamp for backlatching operation of the Prog B.

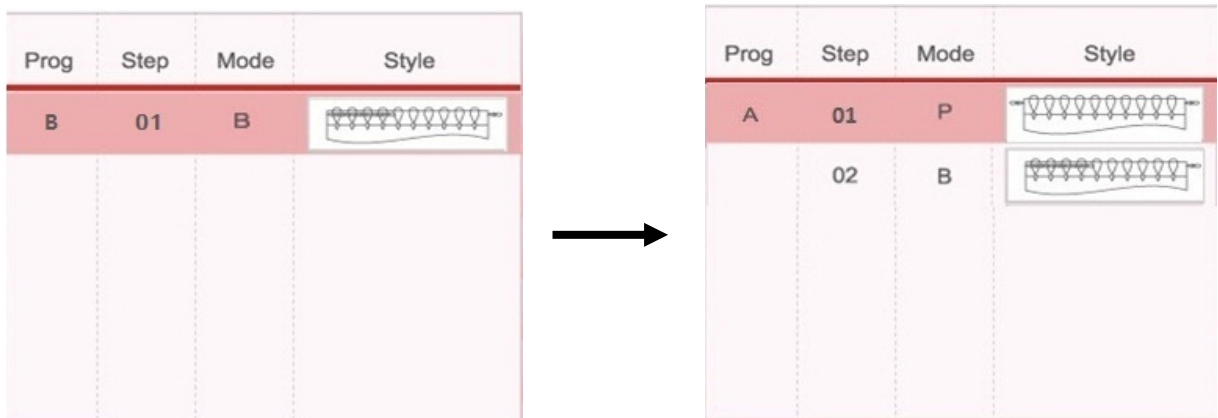

變更為工程 A 後就開始縫紉，即使縫製模式為基本縫 (P)，縫出來還是倒回縫 (B)。為了進行基本縫 (P)，必須踩下踏板或者按下空線鏈重置鍵 ，取掉夾線裝置內的空線鏈。

With the thread chain held in the clamp, the machine performs the Backlatching operation even if the plain seaming is to be performed as the first step. To carry out the plain seaming, press  thread key or the machine treadle so that the thread chain is released from the clamp to get the machine ready for plain seaming.

例2. 當空線鏈沒有被夾線裝置夾住時，則無法完成倒回縫 (B) 的動作，必須下一次縫紉前，踩下踏板或者按下空線鏈重置鍵 ，進行空線鏈重置動作。

As the thread chain is not held with the clamp, a backlatching operation cannot be performed.

Press  thread key or the machine treadle once with toe. The machine gets activated and the thread chain is held in the clamp for the next operation.



### III. 編程畫面 / Programming screen

Prog	Step	Mode	No.	Description	Value
A	01	B	03	SC Start Count	2
	02	B	05	SC End Count	2
	03	B	06	Chain Return Cnt	2
	04	L	25	Clamp	10
	05	P	26	Length	15

Callouts: 1 (Return key), 2 (Prog), 3 (Step), 4 (Mode), 5 (No.), 6 (Description), 7 (Value), 8 (+/-), 9 (Up/Down arrows), 10 (Stitch pattern), 11 (Up/Down arrows), 12 (Return key).

- ①  返回鍵 / Return key

說明：返回到縫製畫面。

Description: back to the sewing screen.

- ②  縫製工程 / Programs

說明：縫製工程,共 A~Z 26 個工程。

Description: the sewing programs, a total of 26 types.

- ③  縫製段數 / Steps

說明：縫製段數, 共有 20 段。

Description: sewing number of step, a total of 20 steps.

**Mode**

## ④ 縫製模式 / Sewing mode

說明：顯示縫製模式,共有 9 種縫製模式(B、P、R、S、Bc、Pc、Rc、Sc、L)。

Description: displays a type of sewing mode, a total of 9 sewing modes(B、P、R、S、Bc、Pc、Rc、Sc、L).

**No.**

## ⑤ 參數代碼 / Parameter no.

說明：參數代碼。

Description: parameter no.

**Description**

## ⑥ 參數名稱 / Parameter name

說明：只顯示該縫製模式相關的參數,無關的參數不顯示,下表為縫製模式和參數的關係表:

Description: show only the sewing mode related parameters unrelated parameters are not displayed. The following table shows the sewing modes and parameters of the relationship table:

No.	Parameter name	P	B	R	S	Pc	Bc	Rc	Sc	L
03	SC Start Count	V	V	V	V					
04	SC Start (Condensed)					V	V	V	V	
05	SC End Count		V				V			V
06	Chain Return Cnt		V	V	V		V	V	V	V
13	MS Start Counter					V	V	V	V	
14	MS Counter					V	V	V	V	
16	RS STOP Counter			V				V		
17	RS Counter			V				V		
21	Special BLSC Cnt				V				V	
22	Loose BL Counter									V
25	Clamp		V	V	V					V
26	Length	V	V	V	V					V
27	C Clamp						V	V	V	
28	C Length					V	V	V	V	
33	P NS CNT	V				V				
34	P NS TEN	V				V				
35	P SE CNT	V				V				

⑦ **Value** 參數設定值 / Parameter value

說明：參數設定值

Description: parameter value



⑧ 參數值調整鍵 / Parameter value ADJ. key

說明：調整參數值用。

Description: to modify the parameter value.

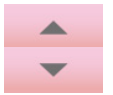

⑨ 參數選擇鍵 / Parameter select key

說明：選擇參數用。

Description: to select parameters.



⑩ 縫製模式選擇鍵 / Sewing mode select key

說明：進入縫製模式選擇畫面,縫製模式選擇畫面如下圖所示：

Description: Enter sewing mode select screen, sewing mode select screen shown below:

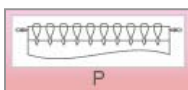
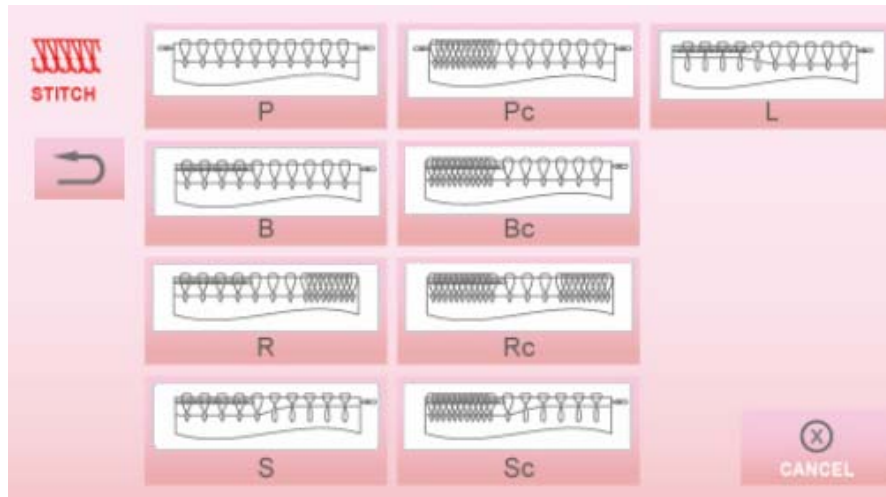

：基本縫 / Plain seaming

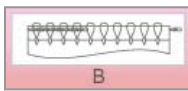

：倒回縫 / Backlatching

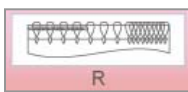

：倒回縫+返回縫 / Backlatching+Reverse stitching

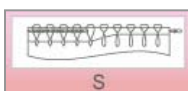

：特殊倒回縫 / Special backlatching

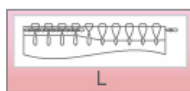

L : 開始縫鬆弛倒回縫 / Loose backlatching

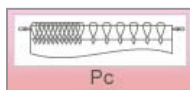

Pc : 基本縫+密縫 / Plain seaming with condensed stitching at the start of sewing

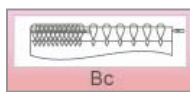

Bc : 倒回縫+密縫 / Backlatching with condensed stitching at the start of sewing

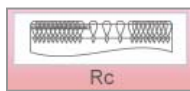

Rc : 倒回縫+返回縫+密縫 / Backlatching with condensed stitching at the start of sewing + Reverse stitching

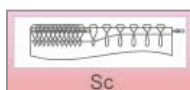

Sc : 特殊倒回縫+密縫 / Special backlatching with condensed stitching at the start of sewing



CANCEL : 刪除縫製模式 / Delete sewing mode

⑪

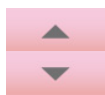

縫製段數選擇鍵 / Step select key

說明：切換縫製段數用。

Description: to switch Step.

⑫

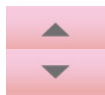

縫製工程選擇鍵 / Programs select key

說明：切換縫製工程用,共 A~Z 26 個工程。

Description: to switch Program, a total of 26 types (A~Z).

## IV. 參數設定畫面 / Parameter setting screen

The screenshot shows a parameter setting screen. On the left, there is a vertical sidebar with a red gear icon and the word 'FUNCTION' above a return key icon (labeled 1). The main area is a table with three columns: 'No.' (labeled 2), 'Description' (labeled 3), and 'Value' (labeled 4). The table contains five rows of parameters. Below the table are two rows of navigation buttons: an up arrow (labeled 6) and a down arrow (labeled 6), and a '+' button (labeled 5) and a '-' button (labeled 5).

No.	Description	Value
01	PL MODE	A
02	PL TIME	100
03	SC Start Count	2
04	SC Start	2
05	SC End Count	2
		+
		-

①  返回鍵 / Return key

說明：返回到縫製畫面。

Description: back to the sewing screen.

②  參數代碼 / Parameter no.

說明：參數代碼。

Description: parameter no.

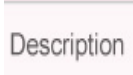
③  參數名稱 / Parameter name

說明：顯示參數名稱。

Description: sew parameter name.

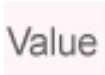
④  參數設定值 / Parameter value

說明：參數設定值。

Description: parameter value.

- ⑤  參數值調整鍵 / Parameter value ADJ key

說明：調整參數值用。

Description: to modify the parameter value.

- ⑥  參數選擇鍵 / Parameter select key

說明：選擇參數用。

Description: to switch parameter.

參數表 1/6 / Parameter List 1/6

NO.	參數名稱 Description	設定值範圍 Range of values	值 Val.	參數的功能說明 Description of the parameters	屬性 Pty.	Oper	Mech
01	PL MODE	Manual / Auto	A	車縫停止時,手/自動抬押腳功能 At motor stop the presser foot by auto or manual	獨	V	V
02	PL TIME	50~2000	150	當光電開關檢知到布後,押腳自動下放的延遲時間,只有 PL MODE 為 AUTO 有效 When the sensor is detection fabric come in, the presser foot goes down delay time adjust. Only valid when 01 PL MODE set at A.	獨	V	V
03	SC Start Count	0~99	2	設定B、P、R、S 起縫時從空線環變為基本縫的針數。 In each mode of B, P, R and S, set the stitch at which the thread chain mode is changed to the plain seaming mode at the start of sewing	獨	V	V
04	SC Start (Condensed)	0~99	2	設定 Bc,Pc,Rc,Sc 起縫時從空線環變為基本縫的針數。 In each mode of Bc, Pc, Rc, and Sc, set the stitch at which the thread chain mode is changed to the plain seaming mode at the start of sewing.	獨	V	V
05	SC End Count	0~98	2	設定從縫紉完的基本縫變為空線環時針數 To set the stitch at which the plain seaming mode is changed to the thread chain mode at the end of sewing	獨	V	V
06	Chain Return Cnt	1~99	4	設定返回夾空線環的針數,此針數結束後,下刀會切斷空環線 To set the stitches at thread chain clamp (left) on. The lower knife will cut thread chain.	獨	V	V
07	End Count	1~99	35	設定從感應器檢知到布邊後到縫紉機自動停止間針數 To setting the stitch number for the sensor detection to fabric edge until to machine stop automatically. PS.此針數設定值必須大於 SC End Count 針數 PS.The 07 End Count value should be more than 05 Sc End Count	獨	V	V
08	Start Mode	M / A	M	縫紉機自動車縫或手動車縫模式選擇 Auto sewing or manual sewing mode select	獨	V	V

參數表 2/6 / Parameter List 2/6

NO.	參數名稱 Description	設定值範圍 Range of values	值 Val.	參數的功能說明 Description of the parameters	屬性 Pty.	Oper	Mech
09	Machine Start Tr	50~2000	50	在縫紉機自動車縫模式時,踩下踏板在返回到中 立位置後,縫紉機起動延遲時間調整, 只有 08 START MODE 為 A 有效 To set the start running delay time, when pedal down then released the pedal . Only valid when 08 START MODE set at A mode.	獨	V	V
10	Item Change with	Mech / Oper	Mech	●"Mech":用維修人員等級的參數設定畫面 Mechanic level parameter setting screen ●"Oper":用操作人員等級的參數設定畫面 Operator level parameter setting screen	共	V	V
12	Condensed Stitch	Off / On	Off	設定使用密縫功能 To select the condensed stitching is used or not	共		V
13	MS Start Counter	0~99	2	設定起縫幾針後密縫功能開始動作,當 12.Condensed Stitch 為 ON 有效 Setting stitches of condensed stitching after start sewing when the 12.Condensed Stitch is set ON.	獨		V
14	MS Counter	0~99	10	設定密縫針數,當 12.Condensed Stitch 為 ON 有效 Adjust the stitches of the condensed stitch when the 12.Condensed Stitch is set ON.	獨		V
15	Reverse Seam	Off / On	On	選擇返回縫功能的 ON/OFF reverse stitching mode is set to ON/OFF	共		V
16	RS STOP Counter	0~99	2	在返回縫模式下,設定從感應器檢知到布邊後到 縫紉機自動停止間針數 When reverse stitching mode is ON, to setting the stitch number for the sensor detection to fabric edge until to machine stop automatically.	獨		V
17	RS Counter	0~99	10	在返回縫模式下,設定將布翻轉後,感應器再次檢 知到布執行返回縫針數 Enter the number of reverse stitches after turning over the fabric when the sensor detection to fabric	獨		V
18	Mesh Counter Set	Off / On	Off	縫紉網眼布料時設定為 ON Select ON when sewing a mesh fabric	共		V
19	Mesh Counter	0~99	3	設定通過網眼孔部分的針數,當 18.Mesh Counter Set 為 ON 有效 Adjust the stitches of the mesh counter when the 18 Mesh Counter mode is set ON	獨		V



參數表 3/6 / Parameter List 3/6

NO.	參數名稱 Description	設定值範圍 Range of values	值 Val.	參數的功能說明 Description of the parameters	屬性 Pty.	Oper	Mech
20	Chain BlowRearTr	50~1500	400	空線鏈返回狀態時吹風時間設定(ms) Blowing time for thread chain function adjust after end of sewing. Note:吹風時間過短會導致線頭無法吹到夾線裝置位置 Note: Blowing time is too short will cause the thread chain cannot left cloth plate get to thread clamp device.	獨		V
21	Special BLSC Cnt	0~99	10	縫製模式 S 或 Sc 時,起縫幾針時解除鬆線功能 Set the stitch at which the thread releasing stops from the start of sewing on S or Sc mode.	獨		V
22	Loose BL Counter	0~99	30	做緊身褲等的鎖縫工序時,將開始縫橡筋部的接縫設定到線鏈壓線處的計數器; 縫製模式L,啟縫時從空線環變為基本縫的針數. In sewing mode of L, set the stitch at which the thread chain mode is changed to the plain seaming mode at the start of sewing	獨		V
23	Set Up Selection	SW / Pedal / SW&Pedal	SW	對於空線鏈動作,可選擇由"面板按鍵"、"腳踏板"或"面板按鍵&腳踏板"進行設置 For thread function key setting that can be by panel or pedal and panel & pedal SW:To perform a SET UP operation by "THREAD"key Pedal:To perform a SET UP operation by pedal SW&Pedal: to perform a SET UP operation by "THREAD"key or pedal	共		V
24	PL Selection	H&P / P / H	P	踏板來源選擇 Pedal control function selection H&P:一般踏板和立作業踏板 support SOP-6 standard pedal and speed control unit. P: 一般踏板: Support speed control unit H: 立作業踏板: Support SOP-6 standard pedal	共		V

參數表 4/6 / Parameter List 4/6

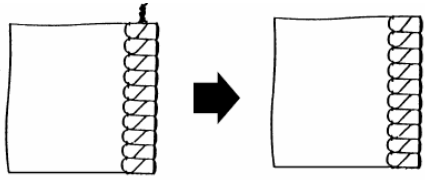
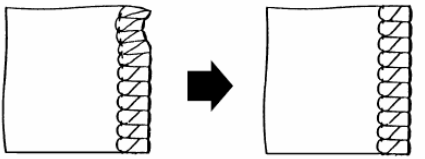
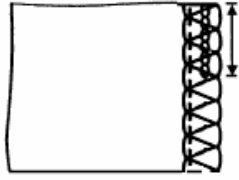



NO.	參數名稱 Description	設定值範圍 Range of values	值 Val.	參數的功能說明 Description of the parameters	屬性 Pty.	Oper	Mech
25	Clamp	0 / 99	15	<p>縫製模式為 B,R,S,L 時,布料起縫處發生收縮或殘留空線鏈時需要進行設定.</p> <p>In each mode of B, R, S and L, Set this counter when a fabric tends to shrink at the start of sewing or when the thread chain knots tend to be produced in backlatching operation.</p> <p>EX: 設定過小,起縫處殘留線頭 EX: When the value is setting too small, the thread chain knots are produced at the start sewing, increase the value to 15</p>  <p>EX: 設定過大,起縫處布料收縮 EX: When the value is setting too much, the fabric shrinks at the start sewing, reduce the value to 15.</p> 	獨	V	V
26	Length	0 / 99	20	<p>縫製模式為 B,R,S,L 時,倒回縫空線鏈長度的設定</p> <p>In each mode of B, R, S and L, to set the backlatching thread chain length</p> <p>在這參數是調整包線頭的長度</p> <p>On this parameter, adjust the thread chain length to be sewn into the seam.</p>  <p>PS. 這個參數值不能小於 25 號參數針數設定 PS. This parameter cannot be less than parameter 25 at the stitches setting.</p>	獨	V	V





參數表 5/6 / Parameter List 5/6

NO.	參數名稱 Description	設定值範圍 Range of values	值 Val.	參數的功能說明 Description of the parameters	屬性 Pty.	Oper	Mech
27	C Clamp	0 / 99	15	縫製模式為 Bc,Rc,Sc,時,布料啟縫處發生收縮或 殘留空線鏈時需要進行設定. In each mode of Bc, Rc and Sc, Set this counter when a fabric tends to shrink at the start of sewing or when the thread chain knots tend to be produced in backlatching operation.	獨	V	V
28	C Length	0 / 99	20	縫製模式為 Bc,Rc,Sc,時,倒回縫空線鏈長度的設 定 In each mode of B, R, S and L, to set the backlatching thread chain length PS. 這個參數值不能小於 27 號參數針數設定 PS. This parameter cannot be less than parameter 27 at the stitches setting.	獨	V	V
33	P NS CNT	1~99	20	P和Pc模式時,設定在縫紉完後布料從感應器抽出 時,縫紉機自動停止的針數 In sewing mode P&Pc, to set the stitch when the machine stops automatically after the fabric has gone through the sensor light.	獨		V
34	P NS TEN	1~99	10	P 和 Pc 模式時,設定在縫紉完後布料從感應器抽 出時,縫紉多少針數後做夾線動作 In sewing mode P&Pc, to set the stitch when the clamp works automatically after the fabric has gone through the sensor light.	獨		V
35	P SE CNT	1~99	1	P和Pc模式時,設定在縫紉完後布料從感應器抽出 時,縫紉機自動車縫多少針數,再執行“Param33.(P NS CNT)”的針數 In sewing mode P&Pc, set the stitch after the fabric has gone through the sensor light, sewing machines, automatic sewing how many stitches, and then execute the “Param33.(P NS CNT)”	獨		V
36	Buzzer On-Off	Off / On	On	按鍵聲的開啟或關閉 To set buzzer on or off	共	V	V

參數表 6/6 / Parameter List 6/6

NO.	參數名稱 Description	設定值範圍 Range of values	值 Val.	參數的功能說明 Description of the parameters	屬性 Pty.	Oper	Mech
37	Safety switch	NO / NC / off	off	設定安全開關模式 set safety switch ,mode NO: Normal Open NC: Normal Close Off: Not used	共	V	V
38	Restore default	nop / run	nop	回復操作盒出廠設定值 Restore parameter default value on the panel	共	V	V
39	LCD auto pwr off	Off / On	Off	LCD 一分鐘自動斷電功能開啟或關閉 LCD minute automatically power-off function is turned on or off	共	V	V
40	LCD brightness	0~99	99	LCD 亮度設定 To set LCD brightness	共	V	V
41	Motor Speed	500 ~ 9999	4000	縫製最高速度設定(spm) The maximum sewing speed adjustment	共		V
*42	Position	0 ~ 359	0	縫紉機針上定位角度調整 The machine up-position angle adjustment	共		V
50	End counter speed	1000~6000	3000	執行空線鍵重置的縫紉速度 sewing speed for "THREAD"key function.	共		V
59	PL Time For Reset	200~3000	200	執行空線鍵重置時,壓腳抬起的持續時間.只在 01 PL Mode=M 時有效 Presser lift time when PL Mode. is set Manual	共		V
60	Air ON time	100~3000	800	每針氣壓閥的持續動作時間(ms) solenoid valve the continuous operation time every stitch.(ms)	共		V
61	NCL on stitch	0 ~999	0	預留 Reserve	共		V
62	NCL off stitch	0 ~999	0	預留 Reserve	共		V
64	Save to default	Nop / Run	Nop	將目前的參數值設定為出廠設定值 the current value of parameters is set to factory settings	共		V

PS. 一般情況下只有顯示參數 01~參數 42, 如果在參數設定畫面下依序按下  →  →  →  後就可以顯示參數 01~參數 64。

PS. Only display Param01 to Param42 under normal circumstances in the parameter setting screen, after pressing  →  →  →  →  will display Param01 to Param64.

\*參數 42.position 僅供微調用,調整時角度不可超過 50 度

\*Parameter42.position is for fine-tuning, adjust the angle of not more than 50 degrees.

## V. 鬆線緊度調整畫面 / Elastic adjustment screen

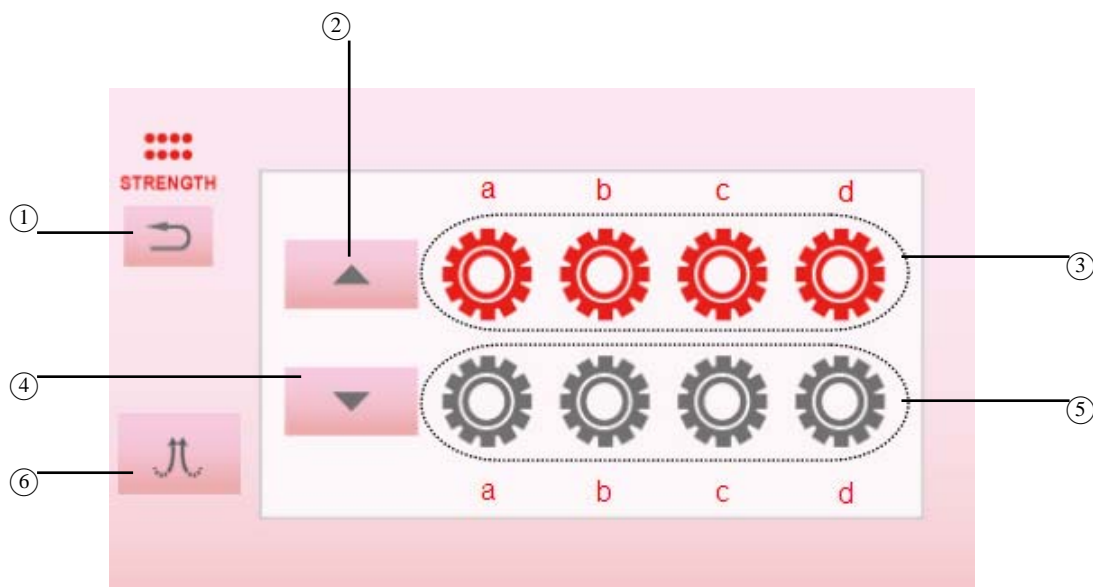

- ①  返回鍵 / Return key

說明：返回到縫製畫面。

Description: back to the sewing screen.

- ②  上排鬆緊裝置動作 / To activate top row elastic device

說明：按此鍵時，上排鬆緊裝置動作，可做線張力調整用。

Description: press this key, activate top row elastic device, can be use as thread tension adjustment.

- ③  上排鬆緊裝置 (基本縫)/ Top row elastic device

說明：上排鬆緊裝置，"a" 與 "b" 為直縫線用，"c" 與 "d" 為環縫線用。

Description: top row elastic device, "a" and "b" for line sewing, "c" and "d" for link sewing.

- ④  下排鬆緊裝置動作 / To activate bottom row elastic device

說明：按此鍵時，下排鬆緊裝置動作，可做線張力調整用。

Description: press this key, activate bottom row elastic device, can be use as thread tension adjustment.

⑤



下排鬆緊裝置 (空線環)/ Bottom row elastic device

說明：下排鬆緊裝置，"a" 與 "b" 為直縫線用，"c" 與 "d" 為環縫線用

Description: bottom row elastic device, "a" and "b" for line sewing, "c" and "d" for link sewing.

⑥



後吸線頭裝置 / Thread rear suction device

說明：啟動或關閉後吸線頭裝置功能

Description: turn on or turn off thread rear suction device

## VI. 裝置測試畫面 / Solenoid valve test screen

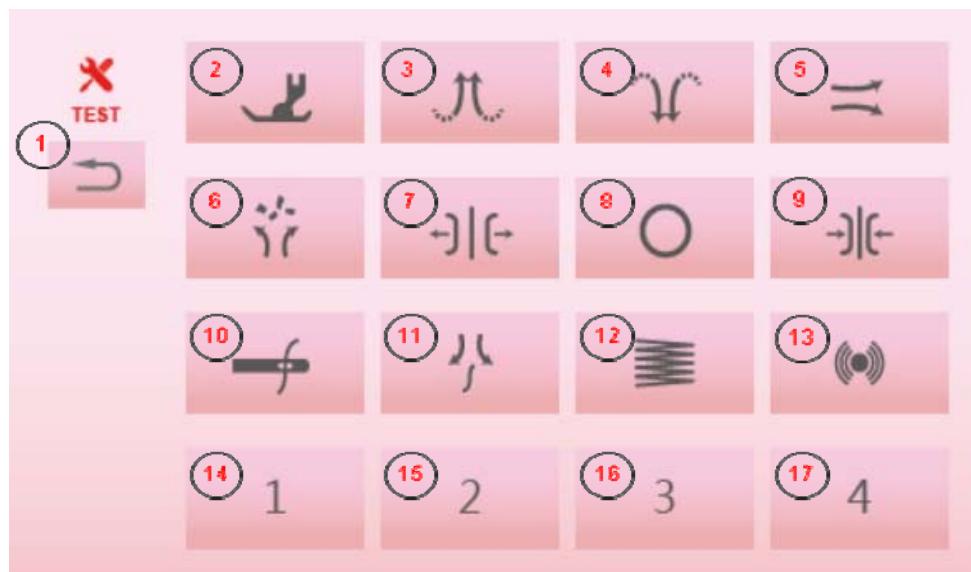
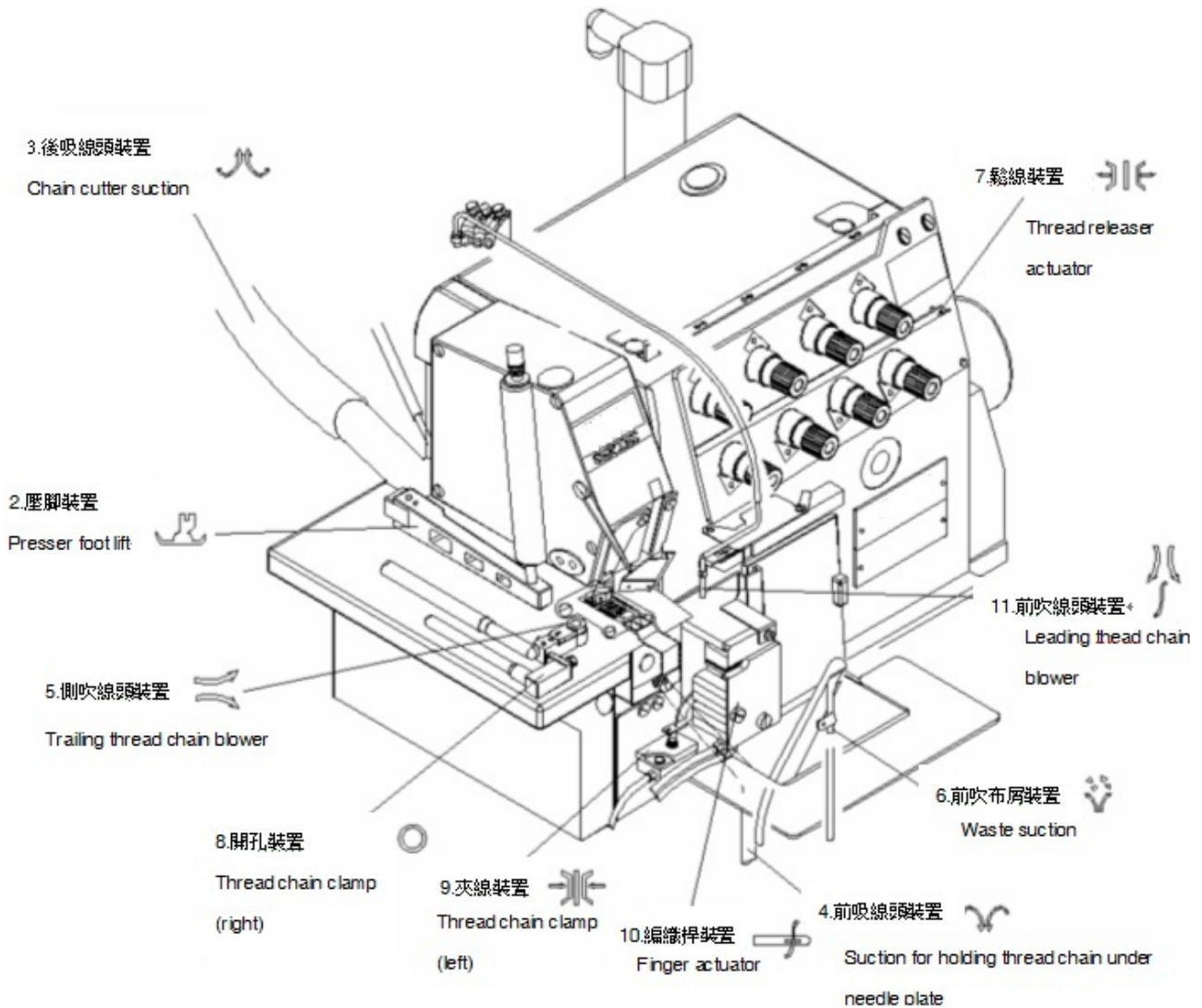

1



返回鍵 / Return key

說明：返回到縫製畫面。

Description: back to the sewing screen.

2



押腳裝置 / Presser foot lifter

說明：押腳功能測試鍵。

Description: check presser foot function.

3



後吸線頭裝置 / Chain cutter suction

說明：後吸線頭裝置測試鍵。

Description: check chain cutter suction function.

4



前吸線頭裝置 / Suction for holding thread chain under needle plate

說明：前吸線頭裝置測試鍵。

Description: check suction for holding thread chain function.

5



側吹線頭裝置 / Trailing thread chain blower

說明：側吹線頭裝置測試鍵。

Description: check trailing thread chain blower function.

6



前吹布屑裝置 / Waste suction

說明：前吹布屑裝置測試鍵。

Description: check waste suction function.

7



鬆線裝置 / Thread releaser actuator

說明：鬆線裝置測試鍵。

Description: check thread releaser actuator function.

8



開孔裝置 / Thread chain clamp(right)

說明：開孔裝置測試鍵。

Description: check thread chain clamp(right) function.



9



夾線裝置 / Thread chain clamp(left)

說明：夾線裝置測試鍵。

Description: check thread chain clamp(left) function.

10



編織桿裝置 / Finger actuator

說明：編織桿裝置測試鍵。

Description: check finger actuator function.

11



前吹線頭裝置 / Leading thread chain blower

說明：前吹線頭裝置測試鍵。

Description: check leading thread chain blower function.

12



密縫裝置 / Cylinder for condensed stitching

說明：密縫裝置測試鍵。

Description: check cylinder for condensed stitching function.

13



蜂鳴器裝置 / Buzzer

說明：蜂鳴器裝置測試鍵。

Description: check buzzer function.

14



保留 / Reserve

15

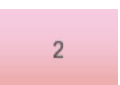

保留 / Reserve

16

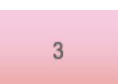

保留 / Reserve

17



保留 / Reserve

## VII. 控制箱說明 / Description of the control box

前視圖 / Front side

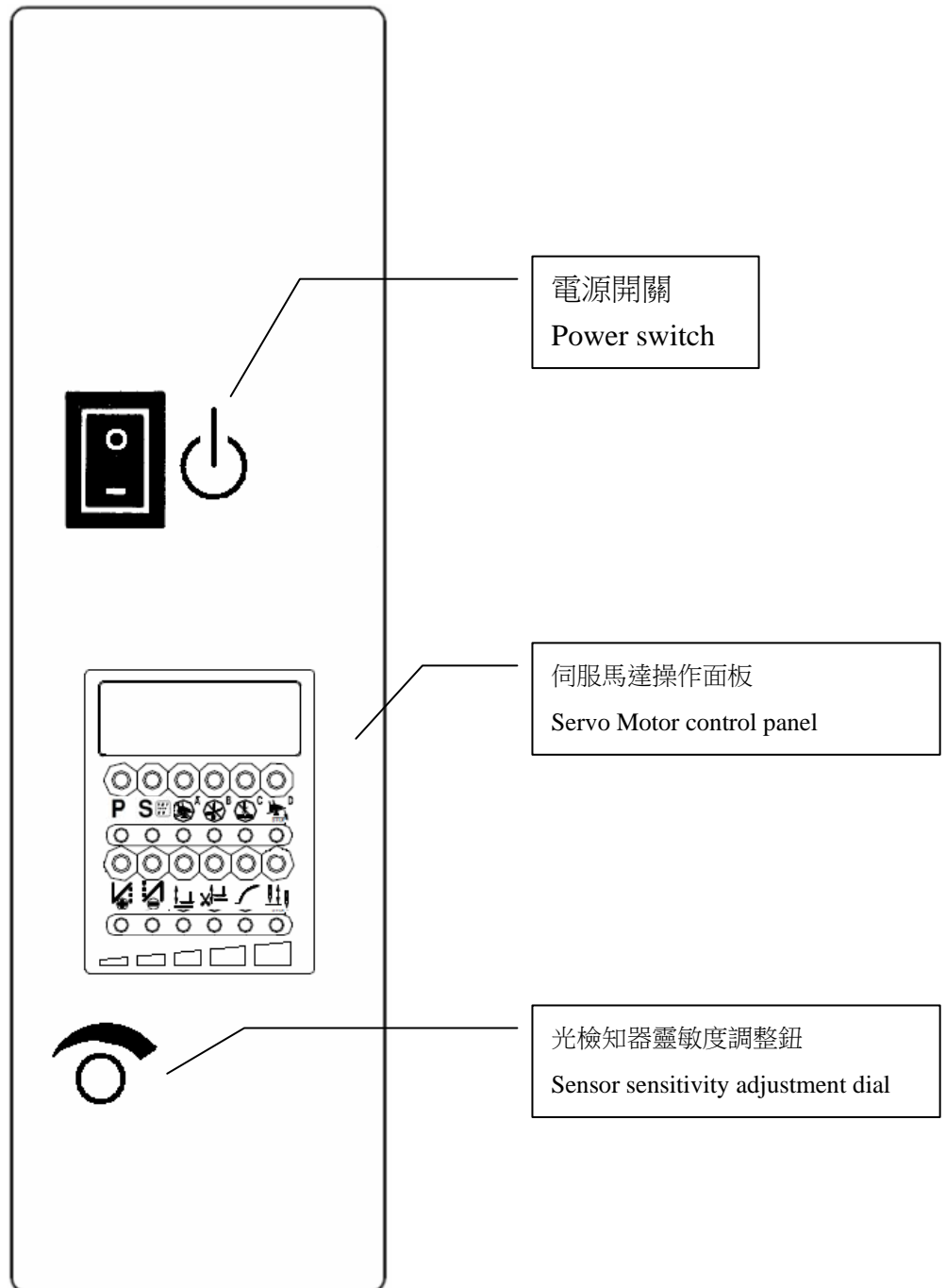

後視圖 / Rear side

ENCODER	
1	+5V
2	UP
3	DOWN
4	A PHASE
5	B PHASE
6	R
7	S
8	T
9	0V

SYNCHRONIZER	
1	---
2	+5V
3	DOWN
4	0V
5	NO SYNC.
6	---
7	UP
8	ENC

LEVER	
1	+12V
2	START
3	VC
4	FRONT
5	VC1
6	BACK
7	KNEE SW.
8	TM
9	0V

OPERATION BOX	
1	+12V
2	---
3	T1out
4	R1in
5	---
6	---
7	T2out
8	R2in
9	0V

SENSOR		
1	+5V	+5V
2	INB	PSD
3		---
4	0V	0V

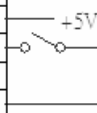

SEWING MACHINE 1			
1	OA	側吹線頭 Trailing thread chain blower	MT
8	+24V	+24V	
2	OB	前吸線頭 Suction for holding thread chain	MY
9	+24V	+24V	
3	OC	後吸線頭 Chain cutter suction	MR
10	+24V	+24V	
4	OD	前吹線頭 Leading thread chain blower	ML
11	+24V	+24V	
5	O2	前吹布屑 Waste suction	VC1
12	+24V	+24V	
6	O7	密縫 Condensed stitching	O7
13	+24V	+24V	
7		---	
14		---	

SEWING MACHINE 2			
1	O1	開線頭孔 Thread chain clamp-R	OP
6	+24V	+24V	
2	OF	押腳 Presser Foot lift	MP
7	+24V	+24V	
3	O3	夾線 Thread chain clamp-L	HP
8	+24V	+24V	
4	O4	鬆線 Thread releaser actuator	O4
9	+24V	+24V	
5	O5	編織桿 Finger actuator	O5
10	+24V	+24V	

OPTION			
1	O6	OUTPUT1	O6
7	+24V	+24V	
2		---	
8		---	
3	IN4	INPUT1	
9	0V	0V	
4	IN5	INPUT2	
10	0V	0V	
5	INL	INPUT3	
11	0V	0V	
6	INF	FL INPUT	
12	0V	0V	

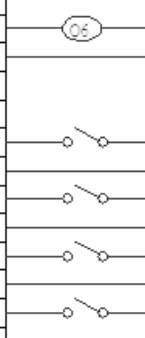

DC+12V LAMP		
1	0V	0V
2	+12V	+12V

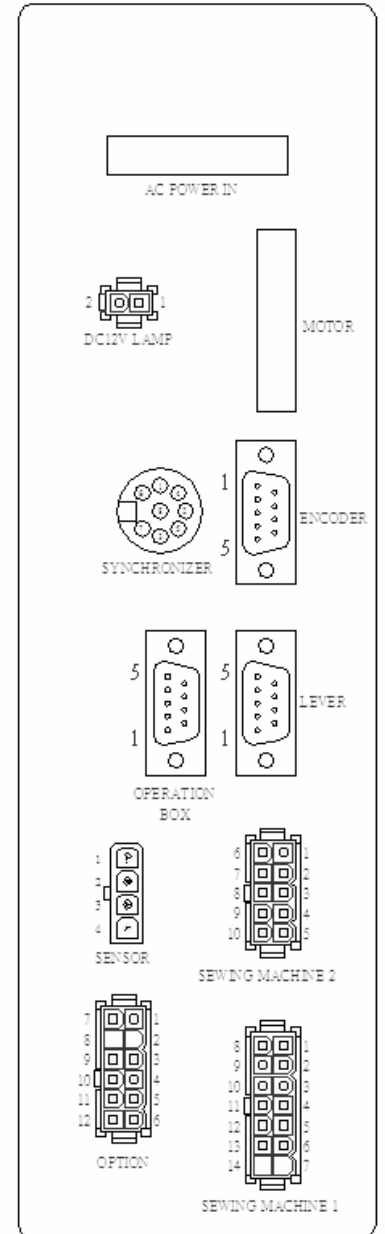



## VIII. 光檢知器靈敏度調整 / Sensor sensitivity adjustment

1 開啟電源 / Turn on the power

2 調整旋鈕 1，直至紅色信號燈 4 個燈亮

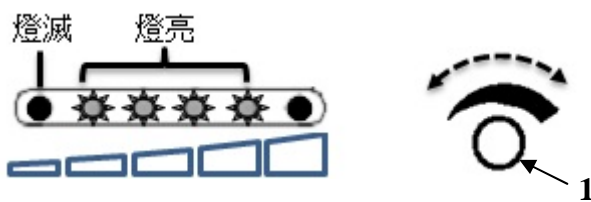
Turn sensitivity adjusting **dial 1** clockwise or counterclockwise until the fourth lamp of red lamps is lit.



3 調整旋鈕 1，往順時鐘方向慢慢旋轉，直至紅色信號燈第 5 個燈亮

Turn **dial 1** clockwise slowly until the fifth red lamp is lit.

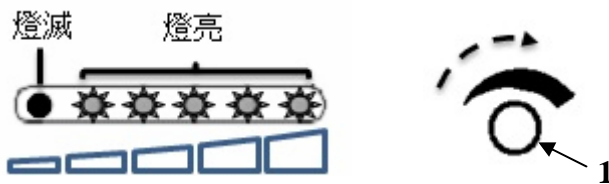

4 確認無布料時，紅色信號燈是否全部亮，橘色信號燈是否熄滅。

Check that orange lamp is turned off and all the red lamps are lit with no fabric under the sensor.

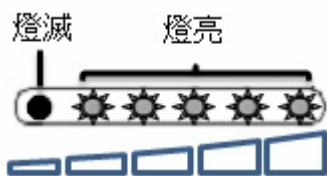

確認有布料時，紅色信號燈是否全部熄滅，橘色信號燈是否燈亮。

Check that orange lamp is lit and all the red lamps are turned off with fabric under the sensor.

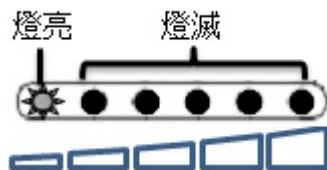

PS. 一般情況下只有橘色信號燈亮才會正常車縫

PS. Only the orange lamp is light the machine can running normal.

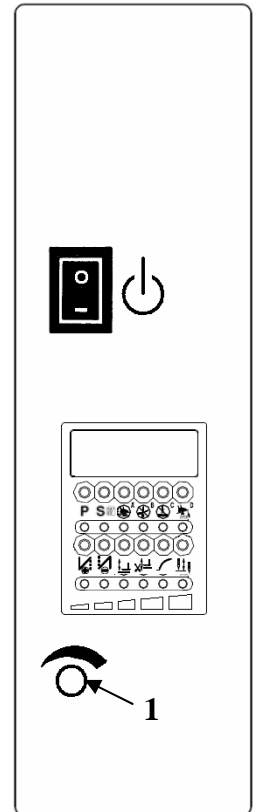

## IX. 錯誤代碼 / Error Code list

控制箱用: / For control box:

錯誤碼 Error Code	故障原因 Cause of the problem	說明 Comment
ER0.4	<p>1.電源 ON 時，主電壓檢知過高時。 2.插錯電壓或供應電壓過高時。</p> <p>1. When power on, detected high voltage. 2. Connect the wrong voltage, too high.</p>	<p>馬達與車頭出力將全部關閉成無動作狀態。 請檢查 AC 電源電壓是否正確或是否超過使用規定的額定電壓。 *如控制箱為 AC 220V 系統, 請勿使用 AC 380V 的電源, 否則於送電 2 秒後出現 ER0. 4 的故障碼。如果持續送入 380V 電源, 則會導致電控箱故障。 請檢查主基板組控制回路機能是否異常。 <b>Motor and machine will be shutting down.</b> <b>Please check the AC power. (Too high)</b> * If control box is AC 220V system, don't use the AC 380V power voltage, otherwise the display will show ER0. 4 after 2 second of power ON. If continue supply the 380V power, the control box will be damage. <b>Please check the main pc board.</b></p>
ER0.7	<p>1.馬達插頭配線接觸不良導致不轉時。 2.馬達編碼器信號異常時。 3.車頭機構鎖死或馬達異物捲入卡住。 4.加工物過厚，馬達扭力不足無法貫穿時。</p> <p>1.Bad connection at the motor connector. 2. Encoder signal error. 3. Machine or motor locked. 4. Sewing material is too thick.</p>	<p>馬達與車頭出力將全部關閉成無動作狀態。 請檢查馬達本身或馬達插頭配線等信號是否異常。 請檢查編碼器信號是否異常。 請檢查車頭是否卡住或干涉轉動困難。 <b>Motor and machine will be shutting down.</b> <b>Please check the motor or motor connectors' connection.</b> <b>Please check the encoder signal.</b> <b>Please check machine head to see if objects stuck in the motor pulley, or rotate not smoothly.</b></p>

<b>ER0.9</b>	<p>1.車頭線圈 (或電磁閥) 短路時。 2.驅動車頭電磁閥之功率電晶體迴路有故障。</p> <p>1. Machine solenoid shorted. 2. Main board's power transistor is faulty.</p>	<p>馬達可正常運轉，所有功能關閉為無效。 請檢查車頭電磁閥(或線圈)之迴路是否短路。 請檢查主基板組之各功率驅動電晶體是否故障。</p> <p>Motor still can run, but all output signals will be invalid.</p> <p>Please check machine's solenoids .</p> <p>Please check which related to power transistors</p>
--------------	---	--











操作盒用: / For operation box:

<b>錯誤碼 Error Code</b>	<b>顯示訊息 Message</b>	<b>說明 Comment</b>
<b>N098</b>	<b>successfully saved</b>	<p>出廠參數值儲存成功。 <b>Factory preset value saved successfully.</b></p>
<b>N099</b>	<b>please reboot</b>	<p>已回復出廠參數值,請重啟電源。 <b>Has returned to factory preset value, please restart the power.</b></p>
<b>E100</b>	<b>No response from front panel</b>	<p>操作盒和控制箱無法互相通信,請檢查操作盒的連接線是否插好或插錯接口。 <b>Operation box can not communicate to control box, please check the operation box cable is plugged in or plugged into the wrong connector.</b></p>



























七段顯示器字體與實際數值對照表：

**7-Segment Display Characters Compare Table**

數值字體部份：（Arabic Numerals）

實際數值 Actual	0	1	2	3	4	5	6	7	8	9
七段顯示器 Display										

英文字體部份：（English Alphabet）

英文數字 (Actual)	A	B	C	D	E	F	G	H	I	J
七段顯示器 (Display)										
英文數字 (Actual)	K	L	M	N	O	P	Q	R	S	T
七段顯示器 (Display)										
英文數字 (Actual)	U	V	W	X	Y	Z				
七段顯示器 (Display)										



高林股份有限公司  
KAULIN MFG. CO., LTD.

由於對產品的改良及更新，本產品使用說明書中與零件圖之產品及外觀的修改恕不事先通知！  
The specification and/or the equipment described in the instruction book and parts list  
are subject to change because of modification with out previous notice  
AUG.2020