

SIRUBA

ORIGINAL

使用說明書與零件圖

INSTRUCTION BOOK & PARTS LIST

700L-BKF1

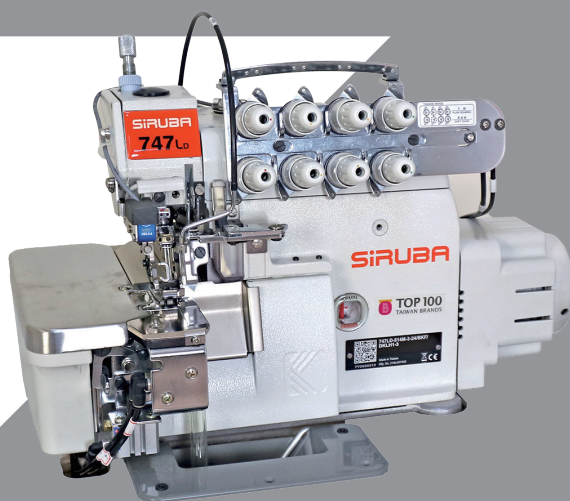

溫馨提醒 A WARM REMINDER

請儘快下載 SIRUBA APP，並將您的機器註冊，以便獲得原廠的保固。APP 還提供多項有用的資訊。

please register your Siruba machine online or through Siruba App at once, as to gain the full warranty protection. You may also acquire more useful information through Siruba APP.



安全警示 GENERAL SAFETY INSTRUCTION

有關於縫紉機，自動化機構，以及其他輔助設備（以下統稱為機器），在工作中無可避免會接近機器移動區域，也就有伴隨著潛在風險。因此，我們強烈要求操作者，維修技師一定要先仔細閱讀並瞭解本操作手冊的內容。安全指示係包含了某些未載於規格書上的加裝配件。現場管理者有責任要求所有操作者要閱讀並瞭解機器的操作與注意事項。未能確實遵守本手冊所記載的事項，將可能導致機器的損害，或是人員的傷亡。

警告標示說明

For the sewing machine, automatic mechanic system, and auxiliary devices (hereinafter referred as “machine”), it is inevitable to conduct work near moving parts of the machine. This means that there is always a potential risk from the moving parts. Operators actually operating the machine and service technicians performing maintenance and repair are strongly advised to read and understand fully the following instructions in advance. The safety instructions include items which are not listed in the specifications of your product. It is the manager/supervisor’s responsibility to have their fellow workers fully understand before operation. Fail to follow the instructions may cause damage to properties, severe injury or even death.

Explanation of warning indications and labels.

	<p>高壓電危險 在機器關機後十分鐘內，勿開啟電控箱。</p> <p>HIGH VOLTAGE DANGER Do not open the power cabinet within 10 minutes after the power off.</p>		<p>零部件移動區 勿接近，以避免人員受傷。</p> <p>Machine moving area! Stay away and keep clear to avoid injury.</p>
	<p>零部件高速移動區 勿接近，以避免人員受傷。</p> <p>High speed moving area! Stay away and keep clear to avoid injury.</p>		

標告標示說明 WARNING LABELS		標告標示說明 WARNING LABELS	
	<p>機器零部件移動區，勿接近，以避免人員損傷。 A risk of cut and injury from moving parts. Stay away and keep clear.</p>		<p>請注意，在操作過程中握住縫紉機會傷到您的手。 Be aware that holding the sewing machine during operation can hurt your hands.</p>
	<p>有電，危險。 A risk of electric shock. Stay away and keep clear.</p>		<p>小心被機械捲件受傷！ There is a risk of entanglement in the belt resulting in injury.</p>
	<p>高溫度區！危險，勿靠近。 A risk of burn from the high temperature area. Stay away and keep clear.</p>		<p>如果觸摸按鈕托架，可能會造成人身傷害。 There is a risk of injury if you touch the button carrier.</p>
	<p>強光！勿直視，以避免眼睛受傷。 Avoid direct eye contact with the laser beam or other light source.</p>	<p>一般安全標示 GENERAL SAFETY INDICATIONS</p>	
	<p>小心頭部撞擊！ A risk of injury to head from upper contact. Apply proper protection (helmet) and keep clear.</p>		<p>機器運行方向 The correct direction is indicated.</p> <p>電氣接地位置標示 Grounding connection as indicated.</p>

安全須知

SAFETY PRECAUTIONS

危險

意外事件將會導致人員受傷甚至死亡，也會造成財產的損害。當有必要進行電控系統的檢修時，務必要關閉電源，並等候至少5分鐘以上才能打開電控箱／操作箱，以避免電擊。

注意

1. 基本預防

- (1) 在操作前務必先閱讀操作手冊與其他機器電件的說明書，請妥善保存操作手冊與說明書以便隨時查閱。
- (2) 這些注意措施包含了機器上加裝，但未列在規格書上的項目。
- (3) 務必要戴護目鏡與手套，以避免破損零件所帶來的傷害。
- (4) 有裝戴心臟調節器的人員，請先詢問醫護人員有關注意事項。

2. 安全裝置與警告標示

- (1) 操作前要檢查，並確認所有的安全設施有妥善安裝且運作正常。
- (2) 若安全設施因維修需要而移動，在機器重新啟動操作前，請確認安全設施有重新安裝回原位，並且運作正常。
- (3) 機器上的安全警告標示要保持完整與可辨視。如果有污損或遺失，請儘以更新。
- (4) 未能確實遵守安全規範，將會導致人員受傷，甚至影響生命安全。

3. 應用與修改

- (1) 嚴格禁止機器使用在非原始設計用途。也禁止以任何不是操作手冊上記載的方式來操作機器。
- (2) 嚴格禁止修改機器。任何未經原廠許可的變動將不在保固範圍內。
- (3) 機台一經修改變動，本公司將不擔負財務損失，人員傷亡的責任。

4. 教育與訓練

- (1) 工廠主管人員有義務提供機台使用人（操作者／維修者）相關的教育訓練。良好的教育訓練不僅可以避免造成人員傷害，也可以避免財產的損失。
- (2) 操作人員操作機器之前，都必需接受過良好的訓練。
- (3) 機器的維修保養必須由合格的技師執行。

5. 必須關閉電源的情況：

如何關閉電源：按壓下緊急停止開關（如果機器有配置的話），關閉電源，拔除電源線。

- (1) 當機器出現異常時，按下緊急停止開關（如果有配置），關閉電源。
- (2) 為了避免機器突然起動造成意外，在操作機器前，要先確定機器電源關閉，再行開啟電源。
- (3) 當檢查或清潔機器時，關閉電源，並確定機器已完全停止運作。
- (4) 當維修機器時（如更換或調整零件），要關閉電源，並確定機器已完全停止運作。

6. 拔除電源線時，務必要抓住電源插頭，而非抓住電源線，以避免斷裂，電擊，甚至火災。

7. 當機器停止運作，且無人看管時，要關閉電源。

8. 萬一停電或電力供應出現不穩，關閉電源，以避免意外發生。

Danger

An accident means " to cause personal injury or death, or damage to property."

When it is necessary to perform service on electrical parts, be sure to turn the power off and wait for 5 minutes or more before opening the power cabinet/box in order to avoid electrical shock.

Caution

1. Basic precaution

- (1) Read the manual and other papers supplied with accessories of the machine before operation. Keep the manual and papers at hand for quick reference.
- (2) The content of this section includes items which are not listed in the specification of your product.
- (3) Always wear safety goggles and gloves to avoid accident caused by parts breakage.
- (4) For those who use a heart pacer, please consult the medical specialist first.

2. Safety devices and warning labels

- (1) Check to ensure all safety devices are correctly installed in place and properly before operation.
- (2) If any of the safety devices is removed for service cause, please be sure to replace it back to position and verify that it works normally before resuming operation.
- (3) Always keep the warning labels adhered on the machine clearly visible. If any of the labels missing or contaminated, replace with a new one at soon.
- (4) Fail to obey instructions above may cause severe injury or death to the operators.

3. Application and modification

- (1) It is prohibited to use the machine for any application other than its original intention, or in any manner other than that prescribed in the instruction manual.
- (2) Never modify or alter the machine. Any unauthorized change of the specification will not be covered by the warranty.
- (3) Our company assumes no responsibility/liability to damages, injuries, or death resulting from the machine which has been modified or altered.

4. Education and training

- (1) The plant managers/supervisors are obliged to provide education and training to operators and service technicians. A good education/training plan not only avoids personal injury but also prevent damage to the property.
- (2) Only a well-trained operator is allowed to operate the machine.
- (3) Only a certified technician is allowed to perform service to the machine.

5. Situations that you must turn off the power

Turning off the power: press EMG Stop (if there is one), switch off the power, and remove the power plug from the outlet.

- (1) When there is a failure or abnormality, press EMG Stop (if there is one), switch off the power.
 - (2) To prevent accident resulting from abrupt start of the machine, before operating the machine, always turn off the power and switch on again.
 - (3) When cleaning or inspecting the machine, make sure the machine stops completely after turning off the power.
 - (4) When performing service (i.e. changing of adjusting any component), make sure the power is off and the machine stops completely.
6. Remove the power plug by holding the plug section instead of the cord to avoid electrical shock, leakage, or fire accident.
7. Turn off the power whenever the machine is left unattended between works.
8. In case of a power failure or black out, turn off the power to avoid damage or accident.

在不同階段的注意事項

1. 運輸

- (1) 當搬運或移動機器時，請考量機器重量，選擇安全合適的方式。請參考機器規格。
- (2) 採取足夠的安全防護，以避免機台在搬運或移動中掉落。
- (3) 為避免意外，運送時不要重覆使用包裝材料。

2. 拆箱

- (1) 在拆箱前，檢查機器是否平穩放置，並採用適當的工具維持拆箱過程的穩定。
- (2) 進行拆箱時，遵循外箱上的指示，小心外箱上的釘子或碎片。

3. 安裝：

3A. 桌板與腳架

- (1) 採用原廠的桌板以確保機器得到足夠的保護與支撐。如果在安裝或維修時，需要暫時將機器置放於物件上，請確定該物件有足夠的支撐力。
- (2) 如果桌板有裝置滾輪，滾輪需要有煞車鎖定機構，而且在操作與維修時，煞車機構必需鎖定。

3B. 電線與管路

- (1) 電線與管路的材質必需符合規範與需求。
- (2) 電線與管路不能夠有折彎或壓迫。移動的零配件上，電線與管路需有至少 30mm 以上的預留量。
- (3) 接線時不能有跳火。
- (4) 所有接頭都必需確實固定。當拆除時，務必要抓住接頭本體。

3C. 接地

- (1) 接地是必需的。且需由合格的技師來施工。
- (2) 在操作前需確認接地有確實。

3D. 馬達

- (1) 馬達的選用，必需符合規範與需求。
- (2) 如果馬達為皮帶傳動，務必要安裝保護措施以避免捲入危險。

4. 在開始操作前

- (1) 在開啟電源前，確認所有接頭，電線，管路都完好無損，確實連結。
- (2) 檢查皮帶輪的轉向與標示為同一方向。
- (3) 確認腳架滾輪都已鎖定。
- (4) 保持作業範圍淨空。

5. 在操作中

PRECAUTIONS TO BE TAKEN IN VARIOUS OPERATION STAGES

1. Transportation

- (1) When lift or move the machine, please take the machine weight into consideration and apply a safe manner. Refer to the specification for the information you need for transportation.
- (2) Apply sufficient safety measures when lifting or moving the machine to avoid falling or dropping.
- (3) To avoid unexpected accident, do not reuse the packing material for transportation.

2. Unpacking

- (1) Before proceeding to unpacking, check the balance of the machine and apply necessary tools to hold the proper position.
- (2) When unpacking, follow the instruction printed on the cartoon. Be careful of the nails and chips when unpacking from a wooden rack.

3. Installation:

3A. Table and Stand

- (1) Only adopt a qualified genuine table and stand to assure the holding support. In case you need to leave the machine on a surface temporarily for service, make sure the surface is strong enough to hold the weight.
- (2) If casters are applied to the table stand, adopt casters with a locking mechanism only and lock them well to secure the machine during the operation and service.

3B. Cable and Wire

- (1) The cables and wires must comply with the specification and requirement.
- (2) The cables and wires shall be free from bending or extra force. Reserve a free space of at least 30mm between cables/wires and the moving parts.
- (3) Do not apply starburst connection when wiring.
- (4) All connectors must be fixed securely. And always hold the connector body when removing it.

3C. Grounding

- (1) Grounding is necessary and must be done by a certified technician. (2) Check and ensure the grounding is secured before operation.

3D. Motor

- (1) The motor must comply with the specification and requirement.
- (2) If there is a belt in the motor transmission, adopt or apply a proper protector to avoid entangling.

4. Before Operation

- (1) Before turning on the power, make sure all the connectors, cables, and wires are free from damage, dropout, or looseness.
- (2) Check and make sure the pulley rotation follows the same direction as labels.
- (3) Make sure all the stand casters are locked or fixed in position.
- (4) Keep the working area clean from obstacles.

5. During Operation

- (1) Always keep your fingers, hair, or clothing away from the moving components and moving area. Do not place your personal belongings on the machine.

- (1) 注意手，頭髮，衣服不在機件移動範圍。不要將個人物品置放於機器上。
- (2) 機器會高速運作。保持雙手遠離移動機件範圍。機器完全停止前不要靠近。
- (3) 在移動物件或重新設定機器時，注意不要被機器或零件撞擊。
- (4) 避免突然起動造成意外，在檢查或維修馬達或皮帶時，務必關閉電源並確認機器完全停止。
- (5) 機器停止時，伺服馬達是無聲的。注意要關閉電源以免突然起動。
- (6) 永遠保持電控箱的風扇與氣道淨空。

6. 潤滑

- (1) 請依照說明書指示，選用合格的油脂來潤滑機件。
- (2) 如果油品接觸到眼睛或身體，立即以清水沖洗。如有不適，立即尋求醫護人員協助。
- (3) 如果油品不慎進入身體，立即尋求最近的醫療協助。

7. 維修保養

- (1) 只有合格的技師或工程師能夠進行維修服務，包含機器調整與修理。只採用原廠的零件進行更換。如果採用非原廠零件，或是因不當維修／調整所造成的傷害，本公司將不負任何責任。
- (2) 只有合格的技師或認證的工程師才能對電控系統進行維修或保養。
- (3) 當對氣動原件（如氣缸）進行維修保養時，務必先拔除風源，並將氣體完全洩除，以避免突然啟動。
- (4) 在調整或更換部件後，檢查所有螺絲是否鎖固。
- (5) 定期清潔是必需的。在清潔前務必先關閉電源，並確認機台完全停止。
- (6) 如果運作異常或不良，立即停止操作並關閉電源。聯絡授權經銷商或我們公司以尋求技術協助。
- (7) 當保險絲故障，立即關閉電源，找出故障原因並予以排除後，更換同規格的新的保險絲。
- (8) 定期檢查與清潔風道，電線與管路。

8. 工作環境

- (1) 機器必需不用電磁波干擾。
- (2) 電源供應必需良好且穩定。電壓波動不得超過 10%。
- (3) 隨時檢查空壓的壓力與品質。如果氣源不穩定，請安裝合適器材以改善。
- (4) 機器操作環境，室溫 5° C ~ 35° C，相對濕度 35%~85%。
- (5) 為了保護電子元件與安全起見，當有劇烈氣溫變化而導致凝水時，立即關閉並拔除電源，並靜候至完全乾燥為止。
- (6) 為了安全起見，當有打電或閃電時，請停止操作，關閉並拔除電源。
- (7) 勿在機器週遭使用電視或收音機，以避免干擾。
- (8) 依當地法令規範，在操作中採取必要的防護。
- (9) 關於包裝材料，潤滑油品，以及機器（含零配件）的丟棄，請依各地政府法規的規範執行。

- (2) The machine is designed to run at high speed. Always keep your hands away from the moving area. Do not resume the work cycle until the machine stops completely.
- (3) Be careful not to be caught by the machine or components when removing or resetting the machine.
- (4) To avoid accident caused by abrupt start, when performing service on the motor or belt, make sure the power is off and the machine stops completely.
- (5) A servo motor is silent as the machine stops. Be sure to turn off the power to avoid an abrupt start. (6) Always keep the fan and airway of the power cabinet clean from any obstacle.

6. Lubrication

- (1) Apply only qualified oil and grease onto the parts as instructed in the manual.
- (2) If the lubricant contacts your eye or body, wash it off immediately. Consult a medical care if necessary.
- (3) If the lubricant goes into your body accidentally, go to the nearby medical care immediately.

7. Service

- (1) Only a certified engineer/technician is allowed to perform service to the machine, including adjusting and repairing. Use only genuine parts for replacement. Our company assumes no responsibility/liability for any accident caused by improper repair or adjustment, or the use of any parts other than genuine one.
- (2) Only a certified technician or authorized engineer is allowed to repair or maintenance the electric system.
- (3) When performing service to air-driven parts, like an air cylinder, first disconnect the air supply and expel the air completely to avoid abrupt start.
- (4) Check all screws and nut are fixed well after adjusting and replacement.
- (5) A periodical cleaning is necessary. Make sure the power is off and the machine stops completely before cleaning.
- (6) If the machine functions poorly or abnormally, stop the operation and turn off the power. Contact the authorized dealers or us to request for a technical service support.
- (7) When there is a fuse failure, turn off the power, find out the cause of the failure and apply solution to it, then replace with a new one with the same spec.
- (8) Periodically check and clean the fan airway and the cable/wiring.

8. Working Environment

- (1) The machine should be free from the affection of electro-magnetic wave.
- (2) The power supply should be in good and reliable condition, the fluctuation of rated voltage should be less than 10%.
- (3) Always check the air pressure and quality. Some extra device might be needed if the supply is not reliable.
- (4) The machine is designed to be used with ambient temperature 5° C ~ 35° C, relative humidity 35%~85%.
- (5) To protect the electronic components and for safety cause, when there is a frost resulting from a dramatic temperature rise, disconnect the power and wait until it dry completely.
- (6) For safety cause, when there is a thundering or lightening, stop the operation and disconnect the power supply.
- (7) Do not use TV or radio nearby the machine as to avoid interference.
- (8) Apply necessary protection during operation. Follow applicable regulations set by local administration.
- (9) For disposal of packages, lubricant, and product, please follow the applicable regulations set by local administration.

索引 INDEX

頁 PAGE

各部件名稱	NAMES OF MAJOR PARTS	1
安裝與調整	INSTALLATION AND ADJUSTMENT	2
縫製畫面	SEWING SCREEN	4
編程畫面	PROGRAMMING SCREEN	7
參數設定畫面	PARAMETER SETTING SCREEN	9
登入使用者畫面	LOGIN USER SCREEN	12
鬆線緊度調整畫面	ELASTIC ADJUSTMENT SCREEN	13
裝置測試畫面	SOLENOID VALVE TEST SCREEN	14
系統設定畫面	SYSTEM SETTING SCREEN	16
警報歷史畫面	HISTORICAL ALARM	16
語言設定畫面	LANGUAGE SETTING SCREEN	17
接管圖	WIRING GRAM	18
提示代碼和錯誤代碼	TIP CODE LIST AND ERROR CODE LIST	19
報廢流程	DEMOLITION PROCEDURE	19
零件圖	PARTS LIST	20

各部件名稱

NAMES OF MAJOR PARTS



- ①控制箱
- ②操作盒
- ③機體
- ④吸風集塵裝置
- ⑤線架

- ① Operation Box
- ② Operation Padel
- ③ Machine
- ④ Dust collecting suction device
- ⑤ Thread Frame

安裝與調整

INSTALLATION AND ADJUSTMENT

(1) 馬達的安裝：請參閱各車頭製造廠之說明書。

Motor installation: Please refer to the machine head's instruction.

(2) 控制箱的安裝：

Control Box Installation:

a). 桌板右側面須預留 100 mm 以上空間
Leave 100 mm space at right

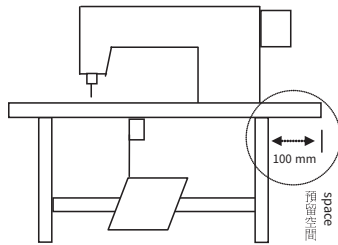

b). 將控制箱鎖裝於桌板下方

Mounting under the working table

尺寸圖 Measurement



c). 安裝後示意圖

Installation layout

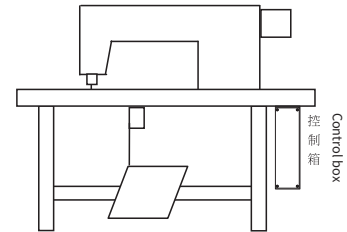

(3) 控速器的安裝：

Speed Control Unit Installation:

a). 控速器與其支架座

Speed Control Unit

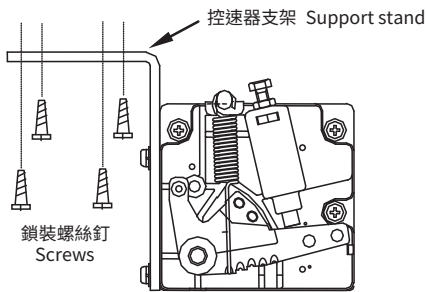

鎖裝螺絲釘時，需以螺絲起子全程鎖裝。

Always use screwdriver to tightly secure screws

b). 保持在吊桿成直線下，將控速器連座鎖於桌板下方

Keep rod in vertical, secure the unit under the table

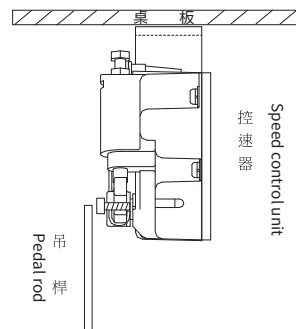

c). 安裝後示意圖

Installation layout

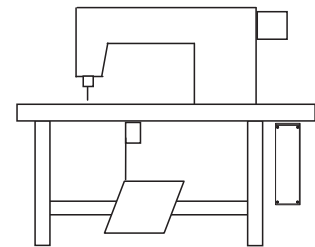

(4) 控速器前/後踏力量的調整：

Adjust the speed control unit:

控速器各部位名稱：如右圖示

Components of the speed control unit: see figure

A：前踏力量彈簧 / Spring for toeing forward force adjustment

B：後踏力量的調整螺栓 / Bolt for heeling backward force adjustment

C：踏板旋臂 / Treadle / Pedal arm

D：腳踏板吊桿 / Pitman Rod for Treadle / Pedal

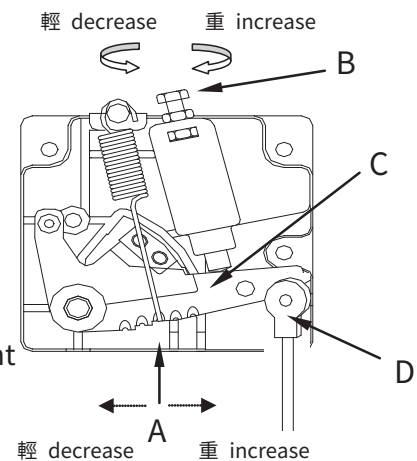

	調整需求 Term of adjustment	調整結果 Adjustment result
1	踏板前踏力量的調整 Toeing forward force adjustment	當彈簧 A 愈向右側勾時，表示力量愈重。 Spring A move to right = force increased. 當彈簧 A 愈向左側勾時，表示力量愈輕。 Spring A move to left = force decreased.
2	踏板後踏力量的調整 Heeling backward force adjustment	當螺栓 B 愈向上 ↖ 時，則後踏力量愈輕。 Bolt B turn ↖ = force decreased. 當螺栓 B 愈向下 ↗ 時，則後踏力量愈重。 Bolt B turn ↗ = force increased.
3	踏板行程長短的調整 Treadle stroke adjustment	當吊桿 D 向右側孔鎖裝時，表示行程較長。 Rod D secure at right = stroke is longer. 當吊桿 D 向左側孔鎖裝時，表示行程較短。 Rod D secure at left = stroke is shorter.

(5) 關於穿線：

Tips for threading:

如果勾針常脫落，請以以下過兩孔的方式穿線。

If looper threads drop out frequently, please change threading by going through two holes, as below pictures.

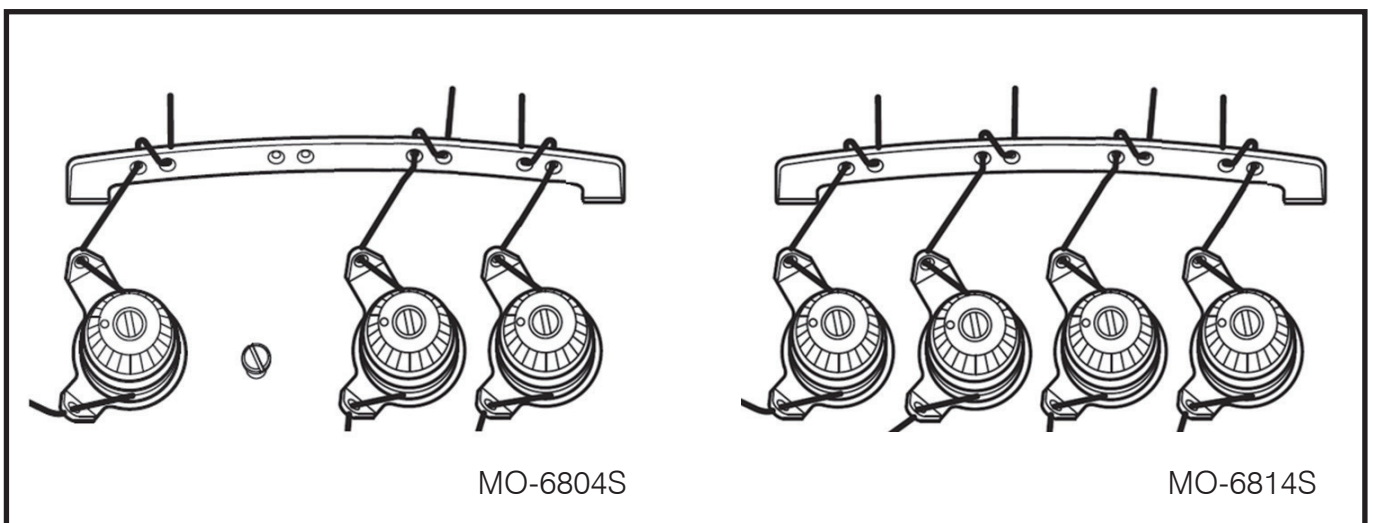

縫製畫面

SEWING SCREEN

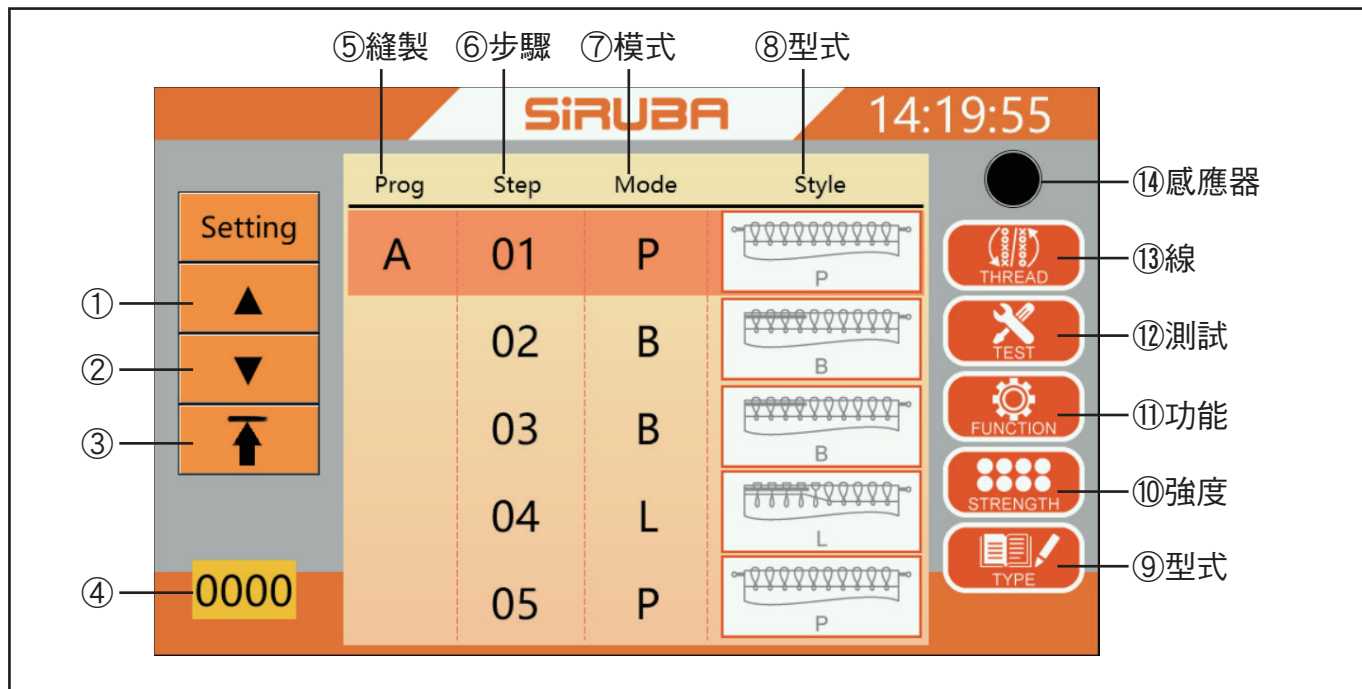

① 螢幕光棒上移鍵
說明：每按一次上移鍵，光棒則返回上一階。

① Shift upward
Description: To go to the previous step when press shift upward key.

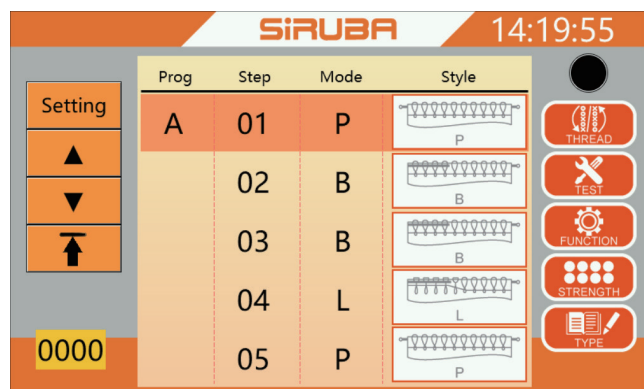

注意！
按此鍵，縫製模式由 Step 02 (B) 返回 Step 01 (P) 或者由 Step 05 (P) 返回 Step 04 (L) 時，必須在 沒有布料的狀態下，踩下踏板或者按下空線鍵重置鍵 ，進行空線鍵重置動作。若縫製模式由 step4 (L) 返回 step3 (B) 時，不必進行空線鍵重置動作。

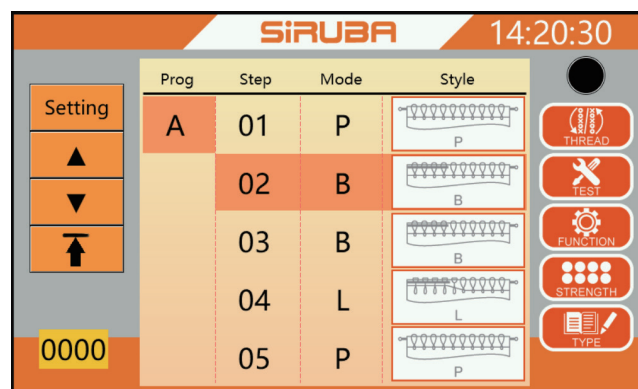

CAUTION!
If the sewing mode returns to Step 01 (P) from Step 02 (B) or to Step 04 (L) from Step 05 (P) when press shift upward key, be sure to press the machine treadle once with no fabric under the sensor or press thread key in order to proceed with the sewing operation. When the sewing mode returns to Step 03 (B) from Step 04 (L), there is no need to press treadle or the thread key.

②  螢幕光棒下移鍵
說明：每按一次下移鍵，光棒則往下一階。

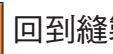
③  回到縫製模式 Step 01
說明：按此鍵後會回到縫製模式 Step 01。

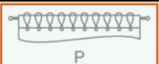
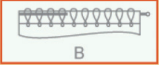
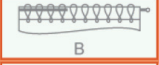
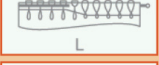
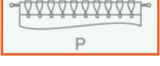
Prog	Step	Mode	Style
A	01	P	
	02	B	
	03	B	
	04	L	
	05	P	





②  Shift downward
Description: To go to the next step when press shift downward key.

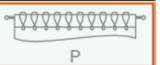
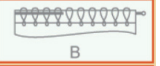
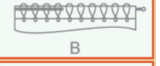
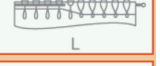
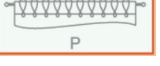

③  Return to the first step
Description: Press key to return to the first step (sewing mode).

Prog	Step	Mode	Style
A	01	P	
	02	B	
	03	B	
	04	L	
	05	P	

注意！

按此鍵 ，縫製模式將由 Step 03 (B) 返回 Sep 01 (P)，必須在沒有布料的狀態下，踩下踏板 或者按下空線鍵重置鍵 ，進行空線鍵重置動作。

CAUTION!

If the operation type (sewing mode) changes by pressing  key, be sure to press the machine treadle once with no fabric under the sensor or press  thread key before starting a sewing operation.

④ **0000** 計數器
說明：按下可選擇是否重置件數計數。

⑤ **Prog** 縫製工程
說明：縫製工程，共 A~Z 26 個工程。

⑥ **Step** 縫製段數
說明：縫製段數，共有 20 段。

⑦ **Mode** 縫製模式
說明：顯示縫製模式，共有 5 種縫製模式 (B、P、R、S、L)。

⑧ **Style** 縫製圖形
說明：顯示各種縫製模式的圖形。

⑨  編輯畫面
說明：按此鍵後進入到編輯畫面。

④ **0000** Counter
Description: Press to select whether to reset the product count.

⑤ **Prog** Programs
Description: the sewing programs, a total of 26 types (A~Z).

⑥ **Step** Steps
Description: sewing number of step, a total of 20 steps.

⑦ **Mode** Sewing mode
Description: displays a type of sewing mode, a total of 5 sewing modes (B、P、R、S、L).

⑧ **Style** Sewing patterns
Description: all kinds of sewing patterns.

⑨  Programming key
Description: to enter the programming screen.

⑩  鬆線緊度調整鍵
 說明：按此鍵會切換到鬆線緊度調整畫面。

⑪  參數設定鍵
 說明：按此鍵會切換到參數設定畫面。

⑫  輸出裝置測試鍵
 說明：按此鍵時會進入輸出裝置測試畫面。

⑬  空線鏈重置鍵
 說明：執行空線鏈重置的動作。

⑭  電眼布料檢知器
 說明：當有檢出到有布料時，由原先黑色變成深紅色。

例 1. 當工程 B (縫製模式為倒回縫 B) 變更為工程 A (縫製模式為基本縫 P) 時，夾線裝置還殘留著工程 B 的空線鏈。

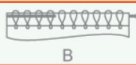
Prog	Step	Mode	Style
A	01	B	

⑩  Strength key
 Description: to adjust the sewing performance after replacing the needle or threading the machine.



⑪  Function key
 Description: press this key, it will switch to the parameter setting mode.

⑫  Device test key
 Description: press key into the solenoid valve test screen.

⑬  Thread key
 Description: To perform a SET UP operation.

⑭  Fabric detecting sensor
 Description: When sensor detected the fabric, the original black would change to dark red.

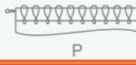
ex.1. When the kind of Prog is changed from B (its first step is backlatching) to A (its first step is plain seaming), the thread chains is still remaining in the clamp for backlatching operation of the Prog B.

Prog	Step	Mode	Style
A	01	P	
	02	B	

變更為工程 A 後就開始縫紉，即使縫製模式為基本縫 (P)，縫出來還是倒回縫 (B)。為了進行基本縫 (P)，必須踩下踏板或者按下空線鏈重置鍵 ，取掉夾線裝置內的空線鏈。

例 2. 當空線鏈沒有被夾線裝置夾住時，則無法完成倒回縫 (B) 的動作，必須下一次縫紉前，踩下踏板或者按下空線鏈重置鍵 ，進行空線鏈重置動作。

With the thread chain held in the clamp, the machine performs the Backlatching operation even if the plain seaming is to be performed as the first step. To carry out the plain seaming, press  thread key or the machine treadle so that the thread chain is released from the clamp to get the machine ready for plain seaming.

ex.2. As the thread chain is not held with the clamp, a backlatching operation cannot be performed. Press  thread key or the machine treadle once with toe. The machine gets activated and the thread chain is held in the clamp for the next operation.

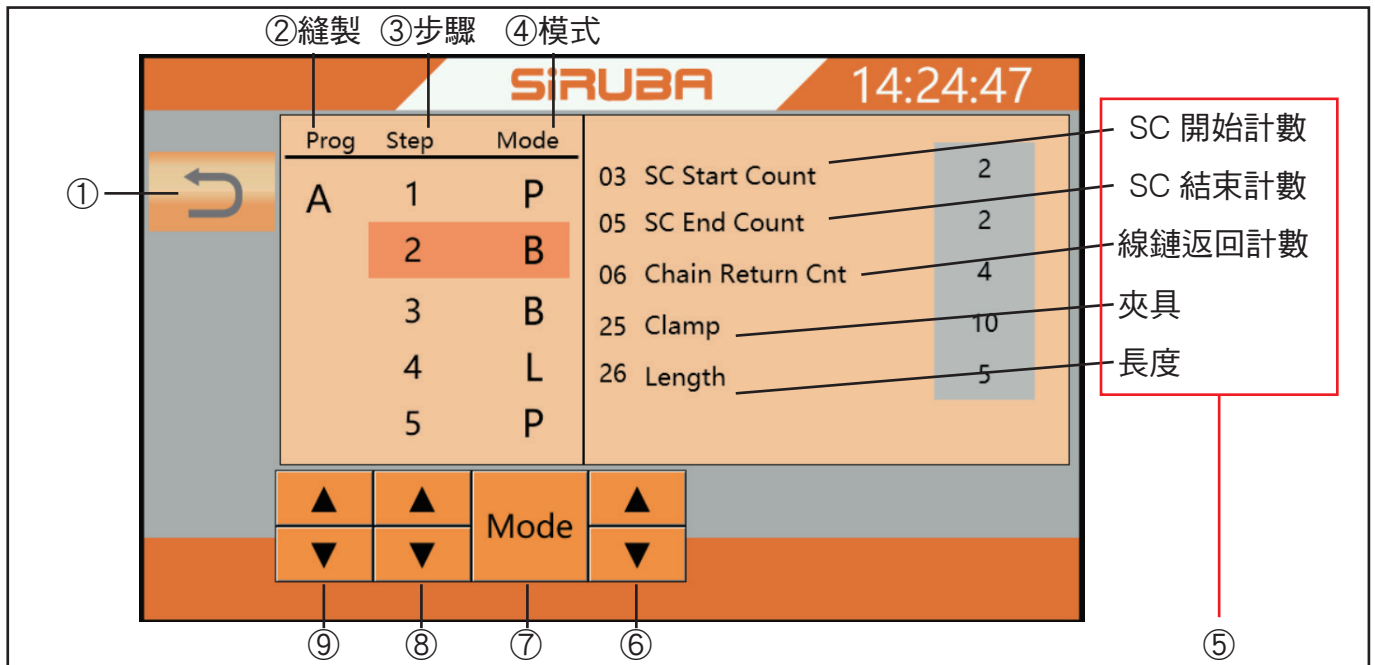

① 返回鍵

說明：返回到縫製畫面。

② **Prog** 縫製工程

說明：縫製工程，共 A~Z 26 個工程。

③ **Step** 縫製段數

說明：縫製段數，共有 20 段。

④ **Mode** 縫製模式

說明：顯示縫製模式，共有 9 種縫製模式 (B、P、R、S、Bc、Pc、Rc、Sc、L)。

⑤ 參數名稱

說明：只顯示該縫製模式相關的參數，無關的參數不顯示，下表為縫製模式和參數的關係表：

① Return key

Description: back to the sewing screen.

② **Prog** Programs

Description: the sewing programs, a total of 26 types.

③ **Step** Steps

Description: sewing number of step, a total of 20 steps.

④ **Mode** Sewing mode

Description: displays a type of sewing mode, a total of 9 sewing modes (B、P、R、S、Bc、Pc、Rc、Sc、L).

⑤ Parameter name

Description: show only the sewing mode related parameters unrelated parameters are not displayed. The following table shows the sewing modes and parameters of the relationship table:

No.	Parameter name / 參數名稱	P	B	R	S	Pc	Bc	Rc	Sc	L
03	SC Start Count / SC 開始計數	V	V	V	V					V
04	SC Start (Condensed) / SC 開始 (密縫)					V	V	V	V	
05	SC End Count / SC 結束計數	V	V			V	V			V
06	Chain Return Cnt 鏈線返回計數		V	V	V		V	V	V	V
13	MS Start Counter / MS 開始計數器					V	V	V	V	
14	MS Counter / MS 計數器					V	V	V	V	
16	RS STOP Counter / RS 停止計數器			V				V		
17	RS Counter / RS 計數器			V				V		
21	Special BLSC Cnt / 特規 BLSC 計數				V				V	
22	Loose BL Counter / 鬆弛 BL 計數器									V
25	Clamp / 夾具	V	V	V	V					V
26	Length / 長度	V	V	V	V					V
27	C Clamp / C 夾具					V	V	V	V	
28	C Length / C 長度					V	V	V	V	

⑥  參數選擇鍵

說明：選擇參數用。

⑦  縫製模式選擇鍵

說明：進入縫製模式選擇畫面，縫製模式選擇畫面如下圖所示：



⑥  Parameter select key

Description: to select parameters.

⑦  Sewing mode select key

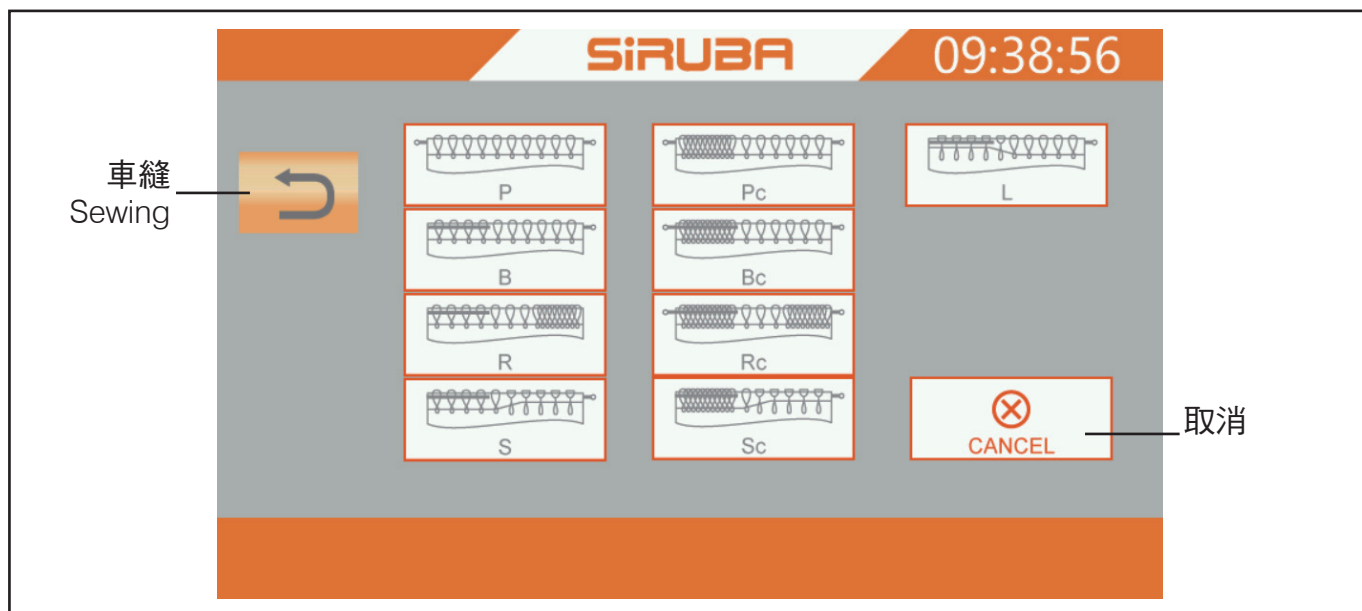
Description: Enter sewing mode select screen, sewing mode select screen shown below:

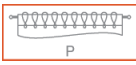
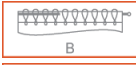
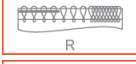
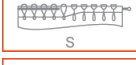





-  : 基本縫
-  : 包線頭
-  : 包線頭 + 返回縫
-  : 特殊包線頭
-  : 開始縫鬆弛包線頭
-  : 刪除縫製模式

⑧  縫製段數選擇鍵

說明：切換縫製段數用。

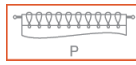
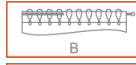
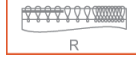
⑨  縫製工程選擇鍵

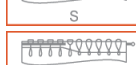
說明：切換縫製工程用，共 A~Z 26 個工程。

-  : Plain seaming
-  : Backlatching
-  : Backlatching+Reverse stitching
-  : Special backlatching
-  : Loose backlatching
-  : Delete sewing mode

⑧  Step select key

Description: to switch Step.

⑨  Programs select key

Description: to switch Program, a total of 26 types (A~Z).

參數設定畫面

PARAMETER SETTING SCREEN

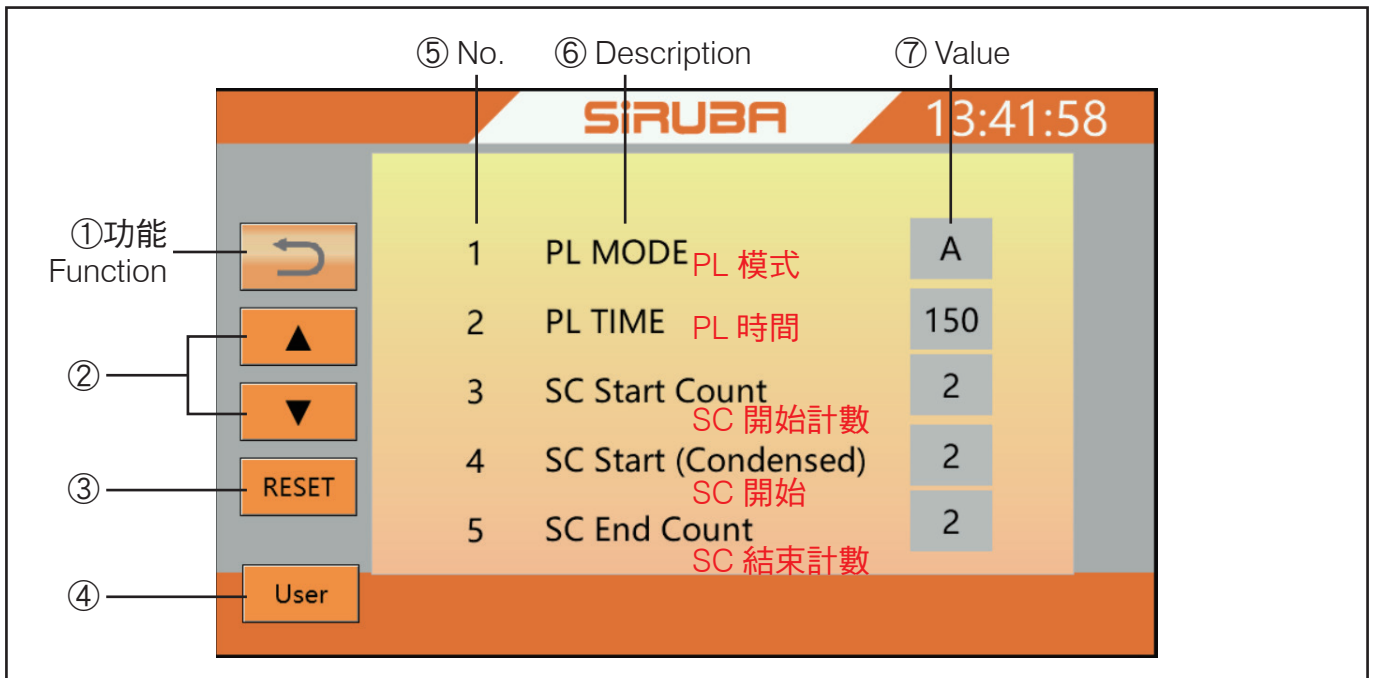

- ① 返回鍵
說明：返回到縫製畫面。
- ② ▲ ▼ 參數選擇鍵
說明：選擇參數用。
- ③ RESET 重置
說明：重置參數。
- ④ User 使用者
說明：使用者權限。
- ⑤ 參數代碼
說明：參數代碼。
- ⑥ 參數名稱
說明：顯示參數名稱。
- ⑦ 參數設定值
說明：參數設定值。

- ① Return key
Description: back to the sewing screen.
- ② ▲ ▼ Parameter select key
Description: to switch parameter.
- ③ RESET Reset
Description: Reset parameters.
- ④ User User
Description: User permission.
- ⑤ Parameter no.
Description: parameter no.
- ⑥ Parameter name
Description: sew parameter name.
- ⑦ Parameter value
Description: parameter value.

NO.	參數名稱 Description	設定值範圍 Range of values	值 Val.	參數的功能說明 of the parameters	屬性 Pty.	O p e r	M e c h
01	PL MODE PL 模式	0=Manual / 1=Auto	A	手 / 自動抬壓腳 PL(presser foot lift)	獨 exclusive	V	V
02	PL TIME PL 時間	50~2000	150	自動抬壓腳的延遲時間 Presser foot timer(ms)	獨 exclusive	V	V
03	SC Start Count SC 開始計數	0~99	2	設定 B、P、R、S 啟縫時從空線環變為基本縫 的針數。 In each mode of B, P, R and S, set the stitch at which the thread chain mode is changed to the plain seaming mode at the start of sewing	獨 exclusive	V	V

04	SC Start (Condensed) SC 開始 (密縫)	0~99	2	設定 Bc,Pc,Rc,Sc 啟縫時從空線環變為基本縫 的針數 . In each mode of Bc, Pc, Rc, and Sc, set the stitch at which the thread chain mode is changed to the plain seaming mode at the start of sewing.	獨 exclusive	V	V
05	SC End Count SC 結束計數	0~98	2	設定從縫紉完的基本縫變為空線環時針數 To set the stitch at which the plain seaming mode is changed to the thread chain mode at the end of sewing	獨 exclusive	V	V
06	Chain Return Cnt 鏈線返回計數	1~99	4	設定返回夾空線環的針數 To set the stitch when the thread chain clamp returns home.	獨 exclusive	V	V
07	End Count 結束計數	1~99	25	設定在縫紉完後布料從感應器抽出時，縫紉機 自動停止，針板中間爪 (雙針) 後退的針數 To set the stitch when the machine stops automatically and the needle plate chaining-off finger (on 2-needle machine) retracts after the fabric has gone through the sensor light.	獨 exclusive	V	V
08	Start Mode 開始模式	M / A	M	選擇縫紉機啟動的自動 / 手動 Select the sewing machine to start automatic / manual	獨 exclusive	V	V
09	Machine Start Tr 機器開始踏板	50~2000	50	縫紉機自動啟動時踩下縫紉機踏板，在返回到 中間位置後，設定幾秒後啟動縫紉機的時間 To set the time interval from the pressed treadle is released to when the machine starts running.	獨 exclusive	V	V
16	RS STOP Counter RS 停止計數	0~99	2	設定當布料從布料感應器下抽出後，縫紉機縫 幾針才停下來 To set the stitch at which the machine stops after the fabric comes off from the fabric detection sensor.	獨 exclusive		V
17	RS Counter RS 計數	0~99	10	設定將布料翻轉後，再縫紉多少針數 / Enter the number of reverse stitches after turning over the fabric.	獨 exclusive		V
18	Reset Speed 重置車縫時間	1000 ~ 6000	3000	重置線練動作時的速度設定 (spm) Reset thread chain speed.	共 sharable		V
19	Reset Needles 重置車縫針數	0 ~ 99	20	重置線練動作時的針數設定 (spm) Reset thread chain needles	共 sharable		V
20	Chain BlowRearTr 空線鏈返回	50~1500	400	設定空線鏈返回狀態氣壓應吹出多少時間 (ms) Adjust the time interval for blowing the thread chain at the end of sewing depending on how the thread chain returns smoothly	獨 exclusive		V
21	Special BLSC Cnt 特規 BLSC 計數	0~99	10	縫製模式 S 或 Sc 時，啟縫幾針時解除鬆線功能 Set the stitch at which the thread releasing stops from the start of sewing on S or Sc mode.	獨 exclusive		V
22	Loose BL Counter 鬆弛 BL 計數	0~99	30	做緊身褲等的鎖縫工序時，將開始縫橡筋部的 接縫設定到線鏈壓線處的計數器；縫製模式 L，啟縫時從空線環變為基本縫的針數 . In sewing mode of L, set the stitch at which the thread chain mode is changed to the plain seaming mode at the start of sewing	獨 exclusive		V

23	Set Up Selection 設置選擇	SW / Pedal / SW&Pedal	SW	對於設置動作，可選擇由”設置開關”、”腳踏板”或”設置開關 & 腳踏板”進行設置 SW: To perform a SET UP operation by “THREAD” key Pedal: To perform a SET UP operation by pedal SW&Pedal: To perform a SET UP operation by “THREAD” key or pedal	共 sharable		V
24	PL Selection PL 選擇	H&P / P / H	P	H&P: 啟用一般踏板和立作業踏板 pedal support standard pedal and twinning P: 啟用一般踏板 / P: support standard pedal H: 啟用立作業踏板 / H: support twinning pedal	共 sharable		V
25	Clamp 夾具	0 / 99	10	縫製模式為 B,R,S,L 時，布料啟縫處發生收縮 或殘留空線鏈時需要進行設定 In each mode of B, R, S and L, Set this counter when a fabric tends to shrink at the start of sewing or when the thread chain knots tend to be produced in backlatching operation	獨 exclusive	V	V
26	Length 長度	0 / 99	5	縫製模式為 B,R,S,L 時，倒回縫空線鏈長度的設定 In each mode of B, R, S and L, to set the backlatching thread chain length	獨 exclusive	V	V
27	C Clamp 夾具	0 / 99	10	縫製模式為 Bc,Rc,Sc 時，布料啟縫處發生收縮或殘留空線鏈時需要進行設定 In each mode of Bc, Rc, Sc, Set this counter when a fabric tends to shrink at the start of sewing or when the thread chain knots tend to be produced in backlatching operation.	獨 exclusive	V	V
28	C Length 長度	0 / 99	5	縫製模式為 Bc,Rc,Sc 時，布料啟縫處發生收縮或殘留空線鏈時需要進行設定 In each mode of Bc, Rc, Sc, Set this counter when a fabric tends to shrink at the start of sewing or when the thread chain knots tend to be produced in backlatching operation.	獨 exclusive	V	V
33	PNS CNT	1~99	20	P 和 Pc 模式時，設定在縫紉完後布料從感應器 抽出時，縫紉機自動停止的針數 In sewing mode P&Pc, to set the stitch when the machine stops automatically after the fabric has gone through the sensor light.	獨 exclusive		V
34	PNS TEN	1~99	10	P 和 Pc 模式時，設定在縫紉完後布料從感應器 抽出時，縫紉多少針數後做夾線動作 In sewing mode P&Pc, to set the stitch when the clamp works automatically after the fabric has gone through the sensor light.	獨 exclusive		V
35	PSE CNT	1~99	1	P 和 Pc 模式時，設定在縫紉完後布料從感應器 抽出時，縫紉機自動車縫多少針數，再執行 “Param33.(P NS CNT)” 的針數 In sewing mode P&Pc, set the stitch after the fabric has gone through the sensor light, sewing machines, automatic sewing how many stitches, and then execute the “Param33.(P NS CNT)”	獨 exclusive		V
41	Motor Speed 馬達速度	500 ~ 9999	4000	縫製最高速度設定 (spm) sewing maximum speed	共 sharable		V
42	Position 定位	0 ~ 359	0	馬達停止角度設定 The angle of motor stop position	共 sharable		V

登入使用者畫面

LOGIN USER SCREEN

The screenshots show the SIRUBA login interface at different times. The top panel (13:42:15) shows the 'Operator' user. The middle panel (13:42:42) shows the 'Mechanic' user. The bottom panel (13:43:10) shows a 'Password Table' dialog box with a table of levels and passwords, and a 'Display Password' checkbox checked.

目前使用者：操作人員
Current user: Operator





目前使用者：維修人員
Current user: Maintenance staff



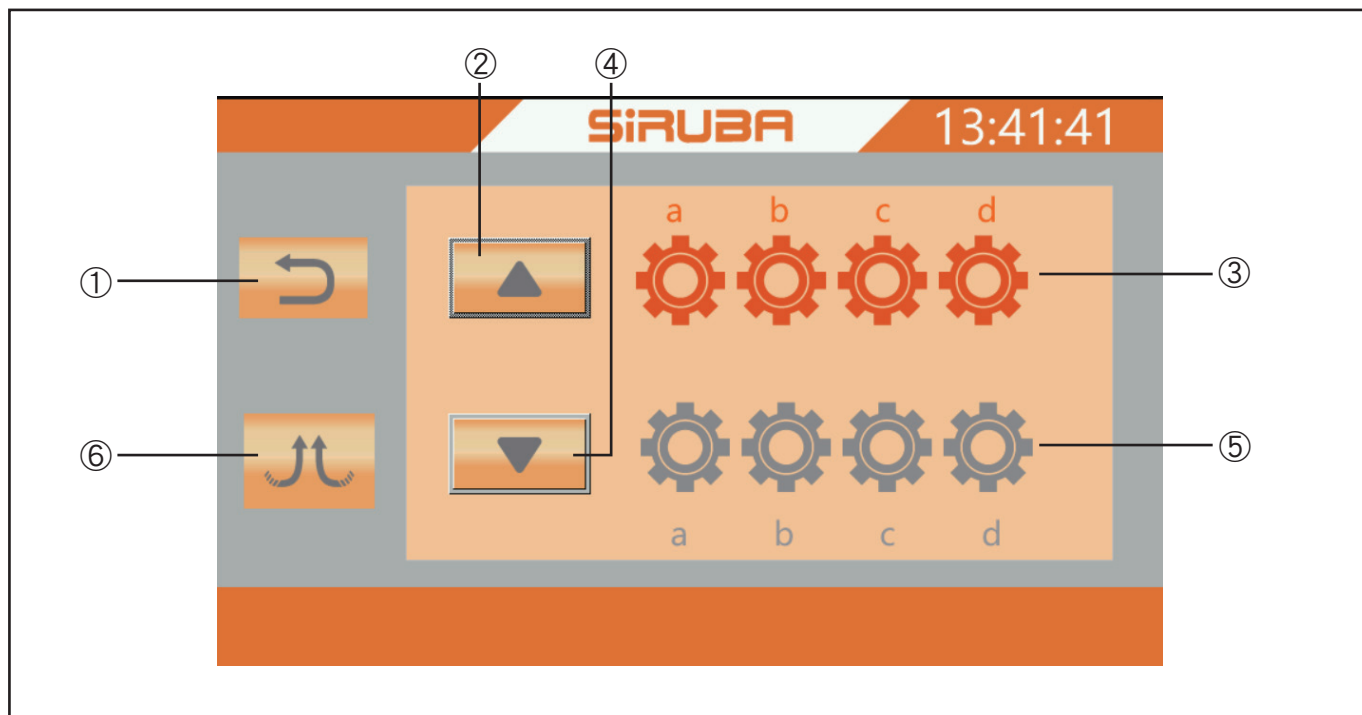



Login：登入（輸入密碼），預設密碼：0168
Logout：登出
Change Password：變更密碼
Login: Login (enter password), default password: 0168

User：開機預設 Operator（操作人員），登入後可切換至 Mechanic（維修人員）。
User: The default Operator (operator) is turned on, and can be switched to Mechanic (maintenance) after logging in.

Level:	Password
1	0168
2	
3	
4	
5	
6	
7	
8	



- ①  返回鍵
說明：返回到縫製畫面。
- ②  上排鬆緊裝置動作
說明：按此鍵時，上排鬆緊裝置動作，可做線張力調整用。
- ③  上排鬆緊裝置
說明：上排鬆緊裝置，"a" 與 "b" 為直縫線用，"c" 與 "d" 為環縫線用。
- ④  下排鬆緊裝置動作
說明：按此鍵時，下排鬆緊裝置動作，可做線張力調整用。
- ⑤  下排鬆緊裝置
說明：下排鬆緊裝置，"a" 與 "b" 為直縫線用，"c" 與 "d" 為環縫線用。
- ⑥  後吸風切線裝置
說明：啟動或關閉後吸線頭裝置功能

- ①  Return key
Description: back to the sewing screen.
- ②  To activate top row elastic device
Description: press this key, activate top row elastic device, can be use as thread tension adjustment.
- ③  Top row elastic device
Description: top row elastic device, "a" and "b" for line sewing, "c" and "d" for link sewing.
- ④  To activate bottom row elastic device
Description: press this key, activate bottom row elastic device, can be use as thread tension adjustment.
- ⑤  Bottom row elastic device
Description: bottom row elastic device, "a" and "b" for line sewing, "c" and "d" for link sewing.
- ⑥  Thread rear suction device
Description: turn on or turn off thread rear suction device

裝置測試畫面

SOLENOID VALVE TEST SCREEN

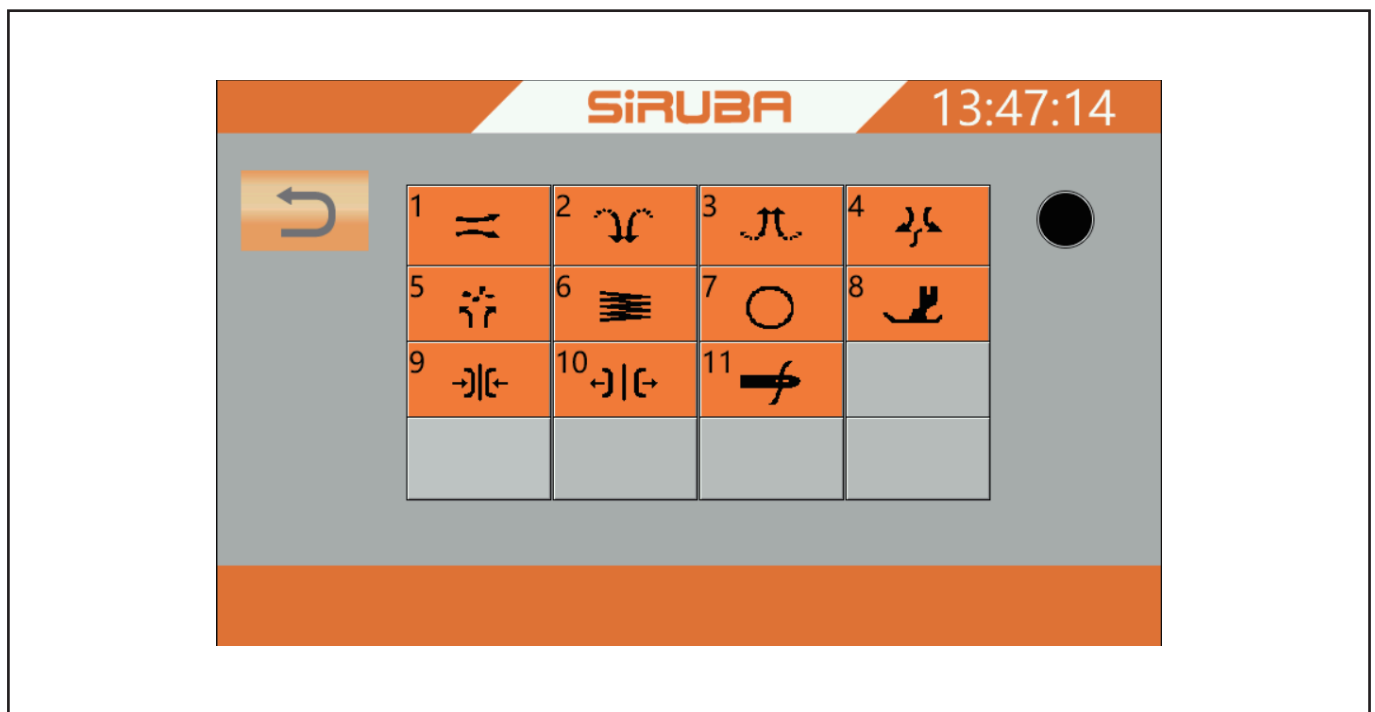
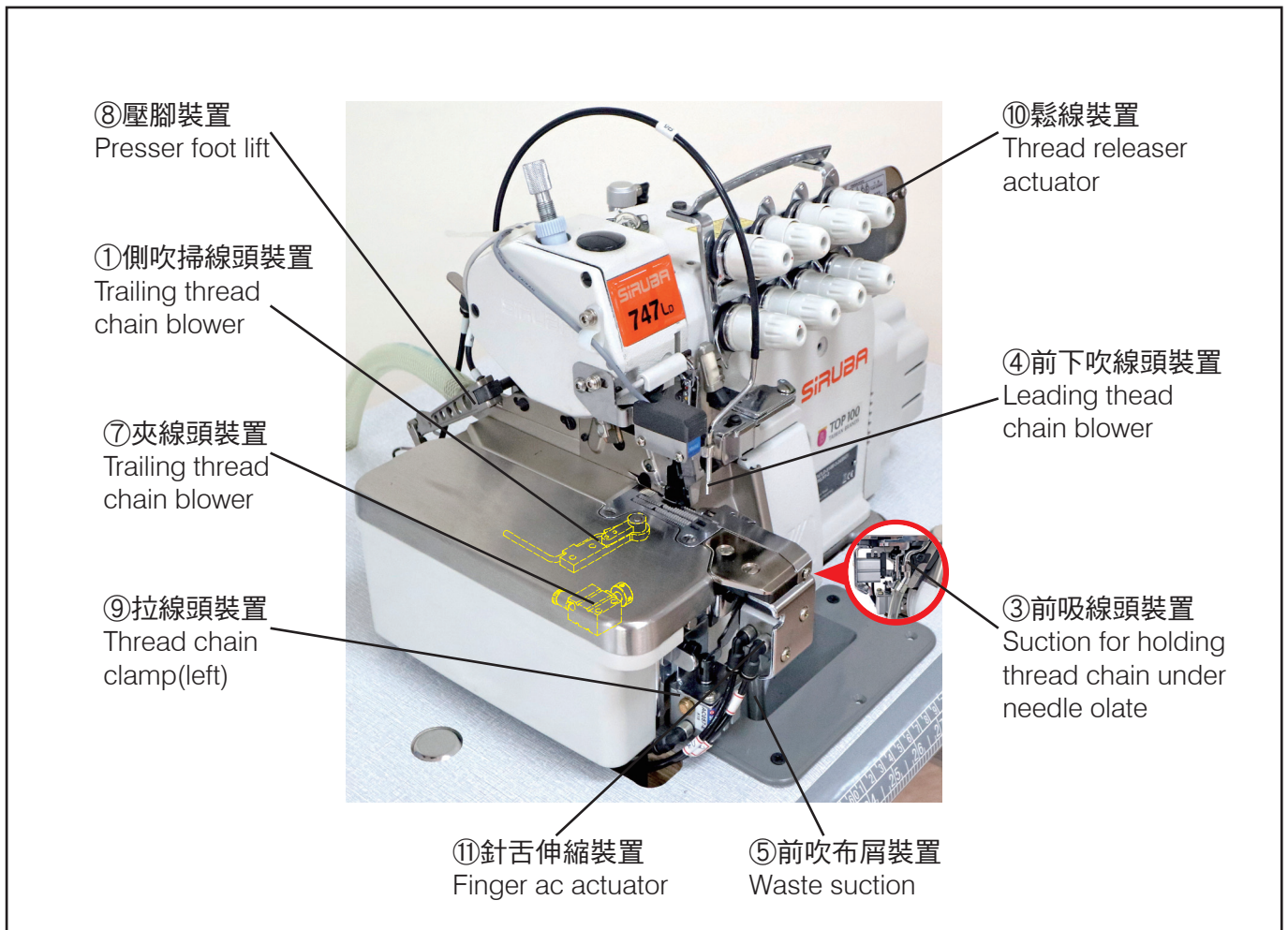



返回鍵

說明：返回到縫製畫面。

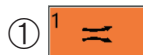

側吹掃線頭裝置

說明：側吹線頭裝置測試鍵。

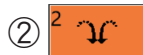

後吸風切線裝置

說明：後吸線頭裝置測試鍵。

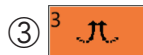

前吸線頭裝置

說明：前吸線頭裝置測試鍵。



前下吹線頭裝置

說明：前吹線頭裝置測試鍵。



前吹布屑裝置

說明：前吹布屑裝置測試鍵。



送具上下

說明：密縫裝置測試鍵。



夾線頭裝置

說明：開孔裝置測試鍵。



押腳裝置

說明：押腳功能測試鍵。

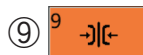

拉線頭裝置

說明：夾線裝置測試鍵。

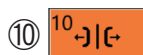

鬆線裝置

說明：鬆線裝置測試鍵。



針舌伸縮裝置

說明：編織桿裝置測試鍵。



Return key

Description: back to the sewing screen.



Trailing thread chain blower

Description: check trailing thread chain blower function.



Chain cutter rear suction

Description: check chain cutter suction function.



Suction for holding thread chain under needle plate

Description: check suction for holding thread chain function.

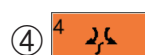

Leading thread chain blower

Description: check leading thread chain blower function.



Waste suction

Description: check waste suction function.



The upper or bottom feed dog

Description: check cylinder for condensed stitching function.



Thread chain clamp(right)

Description: check thread chain clamp (right) function.



Presser foot lifter

Description: check presser foot function.

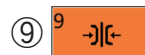

Thread chain clamp(left)

Description: check thread chain clamp(left) function.

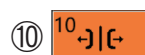

Thread releaser actuator

Description: check thread releaser actuator function.



Finger actuator

Description: check finger actuator function.

系統設定畫面

SYSTEM SETTING SCREEN

變更語言

自動測試模式 (開發測試用)

人機系統設定 (更新人機用)

SIRUBA 14:35:27

Language AUTO TEST BIOS

Historical Alarm

返回前一頁 Return key

警報歷史, 顯示近期發生的錯誤代碼 Showing recent error codes

當前人機版本 Current HMI version HMI VER: 22.08.18

當前控制箱版本 Current control box version MB VER: 22.08.18

警報歷史畫面

HISTORICAL ALARM

SIRUBA 14:37:00

ER.04 Motor over voltage, please turn off!

Date	Time	Code	Clear	Message
18/08/22	14:36	ER.04		Motor over vo

Delete

返回前一頁 Return key

顯示近期發生警報錯誤資料 Displays recent alarm error data

清除報警紀錄 Clear alarm log

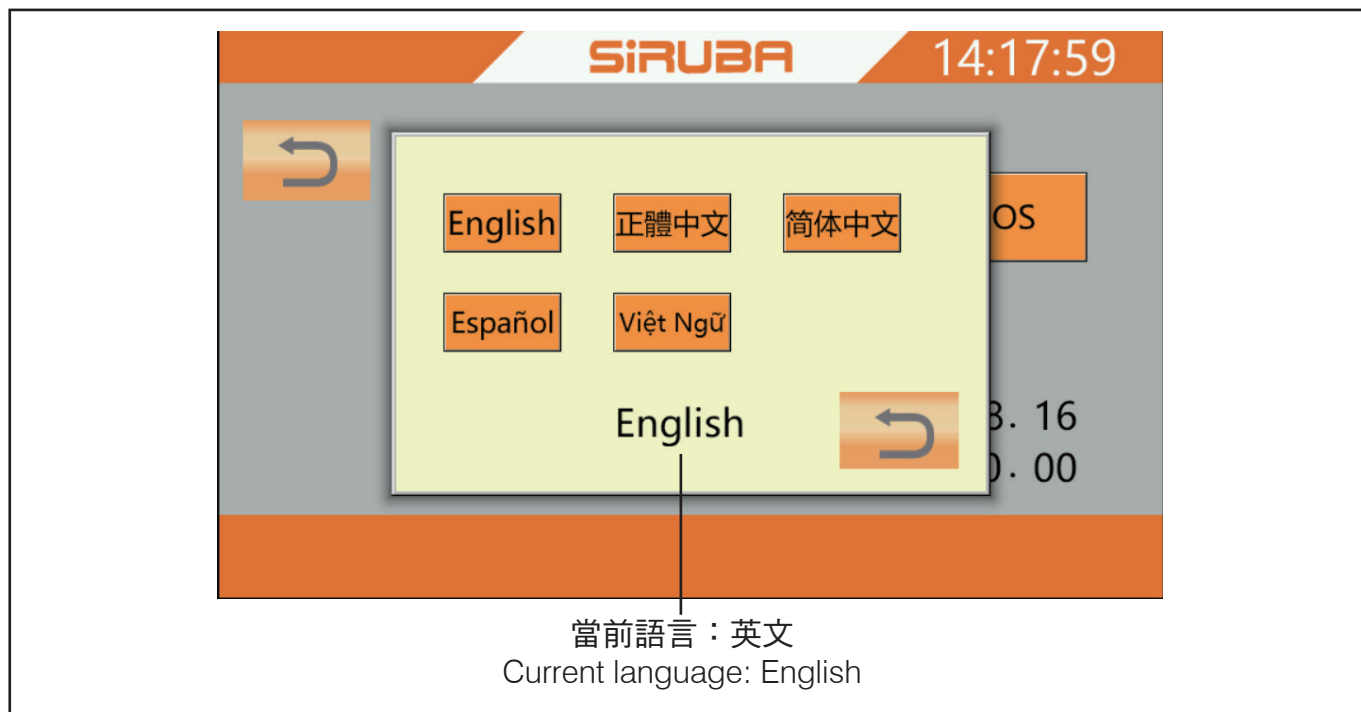

人機更新方式：

- ① 將人機更新檔案存入 USB 隨身碟。
- ② 點選 Setting → Bios 進入人機系統 Bios。
- ③ 點選從檔案更新人機 → 選擇更新檔案路徑 → 確定 → 等待更新完成。
- ④ 執行後即可操作。

HMI update method:

- ① Save the HMI update file to a USB flash drive.
- ② Click Setting → Bios to enter the human-machine system Bios.
- ③ Click Update HMI from file → select update file path → OK → wait for the update to complete.
- ④ It can be operated after execution.

接管圖

WIRING GRAM

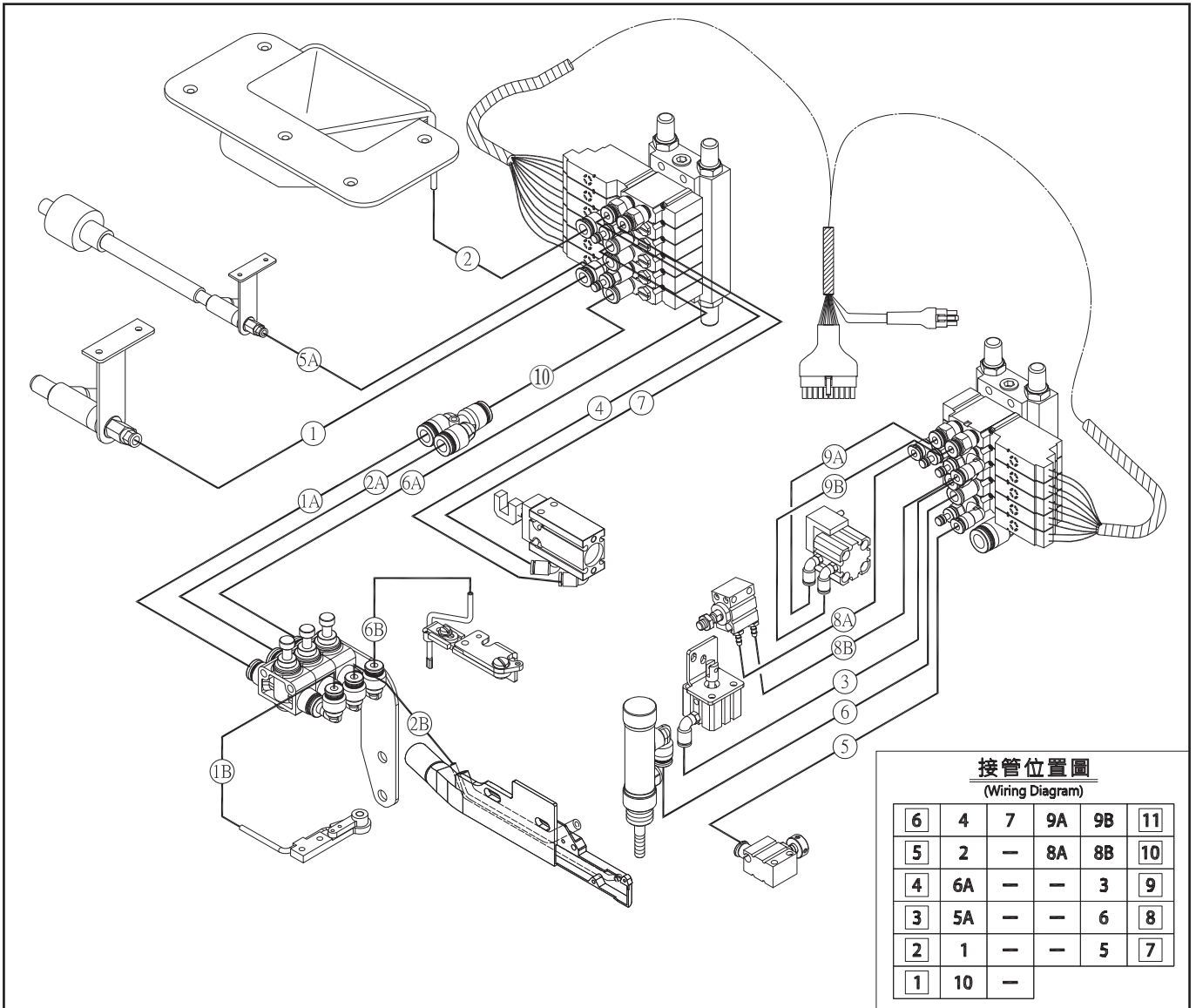

接管位置圖
(Wiring Diagram)

6	4	7	9A	9B	11
5	2	—	8A	8B	10
4	6A	—	—	3	9
3	5A	—	—	6	8
2	1	—	—	5	7
1	10	—			

提示代碼和錯誤代碼

TIP CODE LIST AND ERROR CODE LIST

操作盒用： / For operation box:

提示代碼 Tip Code	顯示訊息 Message	說明 Comment
E.01	Motor over current	馬達過電流，請關閉電源，並聯絡維修人員。 Motor overcurrent, please turn off the power and contact maintenance personnel.
E.02	Motor over load	馬達過電流，請關閉電源，並聯絡維修人員。 Motor overcurrent, please turn off the power and contact maintenance personnel.
E.04	Motor over Voltage.	馬達過電流，請關閉電源，並聯絡維修人員。 Motor overcurrent, please turn off the power and contact maintenance personnel.
E.05	Motor,low valtate.	馬達過電流，請關閉電源，並聯絡維修人員。 Motor overcurrent, please turn off the power and contact maintenance personnel.

操作盒用： / For operation box:

錯誤代碼 Error Code	顯示訊息 Message	說明 Comment
E.11	HMI did not respond	人機無回應，請關電，並檢查人機、電控箱接線是否接觸不良。 If there is no response from the HMI, please turn off the power and check whether the wiring between the HMI and the electric control box is in poor contact.
E.12	Needle count no signal	針數計數無訊號，請關電，並檢查電控箱接線是否接觸不良。 There is no signal for pin count, please turn off the power and check whether the wiring of the electric control box is in poor contact.

報廢流程

DEMOLITION PROCEDURE

- 當機器需要被淘汰與報廢時，有一些基本規則必須採納、遵守以保護環境及公眾健康。
 - 所有的機器零組件必須依照下列分類來區分開：
 - (1) 所有護套、可伸縮軟管及塑膠或非金屬零件。
 - (2) 電器零件：開關、照明器具等。
 - (3) 絕緣材料：石棉、彈性／可伸縮橡膠片。
 - (4) 金屬：含鐵金屬、銅、青銅與黃銅、其他各種金屬。
 - 以此方法，所有材質可以正確的淘汰，回收再利用或鎔解為可再使用或再處理而不至於危害環境。
- When the machine needs to be eliminated and demolished, certain basic rules must be observed to protect the environment and public health.
 - All machine componenets must be divided according to categories as the followings:
 - (1) All sheathes, flexible hosing and plastic or non-metal components.
 - (2) Electricity components: switches, or lighting components.
 - (3) Insulation materials: rock wool, and flexible rubber strips.
 - (4) Metals: ferrous metals, copper, bronze and brass, various.
 - In this way, all materials can be eliminated correctly, recycled, or melted down for reuse or disposed of so that they do not harm the environment.

SIRUBA TABLE CUT - OUT	Series	Item Code	Subclass / Remark	Mounting
	700K	700K-T4	FOR BKF	Non-submerged
				Date
				2015/10/19

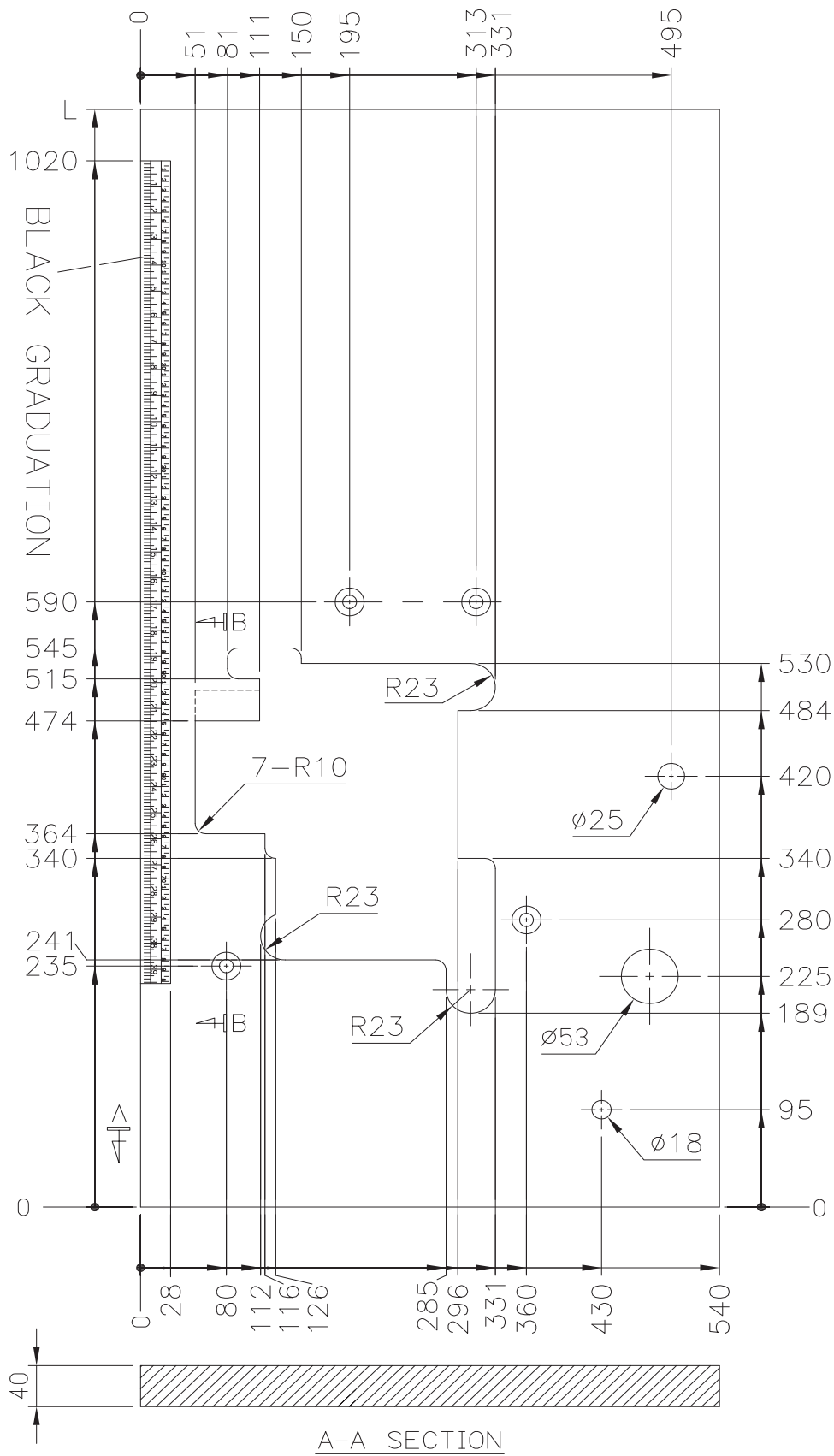

單位/UNIT:mm
 所有尺寸公差/TOLERANCE:±2
 長度(L):1070/重量(W):10.5kg±5%
 長度(L):1200/重量(W):11.5kg±5%

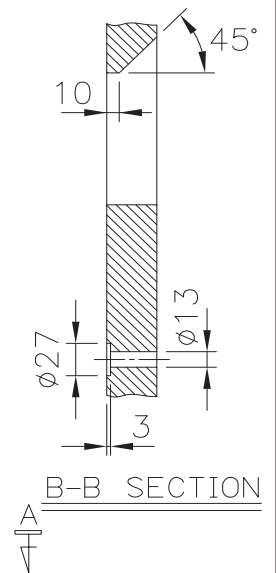

SIRUBA		Series										Remark		Page	Date
GAUGE PARTS LIST		700L												1 / 4	2022/06/29
機 型 MODEL	針板 NEEDLE PLATE	送具 FEED DOG	送具 FEED DOG	送具 FEED DOG	押具 PRESSER FOOT	勾 針 LOOPER	針留 NEEDLE CLAMP	束 子 COLLER	衝 程 CRANK	衝 程 CRANK	大 心 Crankshaft	勾針連桿座 Upper Looper Holder	遮線器 Bracket	下刀架 Lower Knife Holder	針 號 NEEDLE
503M-3-04	E268	D210K	D207	H204K	P220-A1	LP231	KG231K-E	KJ247L-E	KF203-E	KJ206-E	KD201L	KJ236N	KJ219	KR209	DCX27#11
504F-2-04	E250	D201K	D207	H201K	P201-14A	LP225	KG231K-E	KJ247L-E	KF203-E	KJ206-E	KD201L	KJ236N	KJ219	KR209	DCX27#9
504F-2-15	E275	D201K	D217	H201K	P214P-A	LP225	KG231K-E	KJ247L-E	KF203-E	KJ206-E	KD201L	KJ236N	KJ219	KR209	DCX27#9
504F-2-02/GAL	E233K	D201K	D217	H201K	P214P-2A	LP225	KG231K-E	KJ247L-E	KF203-E	KJ206-E	KD201L	KJ236N	KJ219	KR209	DCX27#9
504M-2-15	E207K	D201K	D209	H201K	P211-A	LP225	KG231K-E	KJ247L-E	KF203-E	KJ206-E	KD201L	KJ236N	KJ219	KR209	DCX27#9
504M-3-04	E268	D210K	D207	H204K	P220-A1	LP225	KG231K-E	KJ247L-E	KF203-E	KJ206-E	KD201L	KJ236N	KJ219	KR209	DCX27#11
504M-3-04/LFC-3	E268	D210K	D207	H204K	P216-3	LP225	KG231K-E	KJ247L-E	KF203-E	KJ206-E	KD201L	KJ236N	KJ219	KR209	DCX27#11
504M-3-04/TR	E268	D210K	D207	H204K	P216-3	LP225	KG231K-E	KJ247L-E	KF203-E	KJ206-E	KD201L	KJ236N	KJ219	KR209	DCX27#11
504M-3-04/ECA-U	E222U	D210K	D207	H204K	P201-14A1	LP225	KG231K-E	KJ247L-E	KF203-E	KJ206-E	KD201L	KJ236N	KJ219	KR209	DCX27#11
504M-3-04/ECB-U	E222U	D210K	D207	H204K	P201-14A1	LP225	KG231K-E	KJ247L-E	KF203-E	KJ206-E	KD201L	KJ236N	KJ219	KR209	DCX27#11
504M-3-04/VTE-U	E222U	D210K	D207	H204K	P201-14A1	LP225	KG231K-E	KJ247L-E	KF203-E	KJ206-E	KD201L	KJ236N	KJ219	KR209	DCX27#11
737L	E246					LP225	KG231K-E	KJ247L-E	KF203-E	KJ206-E	KD201L	KJ236N	KJ219	KR209	DCX27#11
504M-3-05	E274	D210K	D207	H204K	P220-A1	LP225	KG231K-E	KJ247L-E	KF203-E	KJ206-E	KD201L	KJ236N	KJ219	KR209	DCX27#11
504M-3-05/PZ	E274	D210K	D207	H204K	P257-A	LP225	KG231K-E	KJ247L-E	KF203-E	KJ206-E	KD201L	KJ236N	KJ219	KR209	DCX27#18
504M-7-04/BK	E232	D203K	D207	H203K	P202-2A	LP225	KG231K-E	KJ247L-E	KF203-E	KJ206-E	KD201L	KJ236N	KJ219	KR209	DCX27#11
504M-7-04/BK-1	E232	D203K	D207	H203K	P202-2A	LP225	KG231K-E	KJ247L-E	KF203-E	KJ206-E	KD201L	KJ236N	KJ219	BK239	DCX27#11
505F-2-04	E250	D201K	D207	H201K	P203-A	LP225	KG231K-E	KJ247L-E	KF203-E	KJ206-E	KD201L	KJ236N	KJ219	KR209	DCX27#9
504F-2-15/VTE	E275	D201K	D217	H201K	P214P-A	LP225	KG231K-E	KJ247L-E	KF203-E	KJ206-E	KD201L	KJ236N	KJ219	KR209	DCX27#9
504M-3-04/ECA	E268	D210K	D207	H204K	P220-A3	LP225	KG231K-E	KJ247L-E	KF203-E	KJ206-E	KD201L	KJ236N	KJ219	KR209	DCX27#11
504M-3-04/ECB	E268	D210K	D207	H204K	P220-A3	LP225	KG231K-E	KJ247L-E	KF203-E	KJ206-E	KD201L	KJ236N	KJ219	KR209	DCX27#11
504M-3-04/VTE	E268	D210K	D207	H204K	P220-A3	LP225	KG231K-E	KJ247L-E	KF203-E	KJ206-E	KD201L	KJ236N	KJ219	KR209	DCX27#11
504M-3-03/BkF	E263	D210K	D217	H204K	P202-5A	LP225	KG231K-E	KJ247L-E	KF203-E	KJ206-E	KD201L	KJ236N	KJ219	KR209	DCX27#11
504M-3-04/BkF	E264	D210K	D217	H204K	P202-5A	LP225	KG231K-E	KJ247L-E	KF203-E	KJ206-E	KD201L	KJ236N	KJ219	KR209	DCX27#11
504M-3-05/BkF	E265	D210K	D217	H204K	P202-5A	LP225	KG231K-E	KJ247L-E	KF203-E	KJ206-E	KD201L	KJ236N	KJ219	KR209	DCX27#11
512M-3-25	E276	D210K	D207	H204K	P220-A2	LP228	KG242K-E	KJ247L-E	KF215-E	KJ203-E	KD201L	KJ208N	KJ219	KR209	DCX27#11*2
512M-3-34	E236	D210K	D207	H204K	P214-A	LP228	KG254K-E	KJ247L-E	KF215-E	KJ203-E	KD201L	KJ228N	KJ219	KR209	DCX27#14*2
514M-8-24/GA	E252	D202K	D207	H202K	P204-A	LP226	KG242K-E	KJ246L-E	KF203-E	KJ203-E	KD201L	KJ208N	KJ219	KR209	DCX27#11*2
514M-8-24/GA/P	E252	D202K	D207	H202K	P204P-A	LP226	KG242K-E	KJ246L-E	KF203-E	KJ203-E	KD201L	KJ208N	KJ219	KR209	DCX27#11*2

SIRUBA GAUGE PARTS LIST		Series										Remark		Page	Date
		700L												3 / 4	2022/06/29
機 型 MODEL	針板 NEEDLE PLATE	送具 FEED DOG	送具 FEED DOG	押具 PRESSER FOOT	勾 針 LOOPER	針留 NEEDLE CLAMP	束 子 COLLER	衝 程 CRANK	衝 程 CRANK	大 心 Crankshaft	勾針連桿座 Upper Looper Holder	過線器 Bracket	下刀架 Lower Knife Holder	針 號 NEEDLE	
747L	514M-7-23/BK-1	E210	D203K D207	H203K P202-A	LP226	KG242K-E	KJ246L-E	KF203-E	KJ203-E	KD201L	KJ208N	KJ219	BK239	DCX27#11x2	
	514M-7-24/BK	E247	D203K D207	H203K P202-A	LP226	KG242K-E	KJ246L-E	KF203-E	KJ203-E	KD201L	KJ208N	KJ219	KR209	DCX27#11x2	
	514M-7-24/BK-1	E247	D203K D207	H203K P202-A	LP226	KG242K-E	KJ246L-E	KF203-E	KJ203-E	KD201L	KJ208N	KJ219	BK239	DCX27#11x2	
	514H-4-24	E226	D212 D207	H210 P220-A	LP230	KG242K-E	KJ248L-E	KF203-E	KJ203-E	KD201LA	KJ228N	KJ238	KR209	DCX27#16x2	
	514H-4-24/TC	E226	D212 D207	H210 P226-A	LP230	KG242K-E	KJ248L-E	KF203-E	KJ203-E	KD201LA	KJ228N	KJ238	KR209	DCX27#16x2	
	514H-4-25/ECA-U	E225U	D212 D207	H210 P201U-A1	LP230	KG242K-E	KJ248L-E	KF203-E	KJ203-E	KD201LA	KJ228N	KJ238	KR209	DCX27#16x2	
	514H-4-25/ECB-U	E225U	D212 D207	H210 P201U-A1	LP230	KG242K-E	KJ248L-E	KF203-E	KJ203-E	KD201LA	KJ228N	KJ238	KR209	DCX27#16x2	
	514H-4-25	E225	D212 D207	H210 P220-A	LP230	KG242K-E	KJ248L-E	KF203-E	KJ203-E	KD201LA	KJ228N	KJ238	KR209	DCX27#16x2	
	514H-4-25/TC	E225	D212 D207	H210 P226-A	LP230	KG242K-E	KJ248L-E	KF203-E	KJ203-E	KD201LA	KJ228N	KJ238	KR209	DCX27#16x2	
	514H-7-24/BK	E247	D203K D207	H203K P202-A	LP230	KG242K-E	KJ248L-E	KF203-E	KJ203-E	KD201LA	KJ228N	KJ238	KR209	DCX27#16x2	
	514H-7-24/BK-1	E247	D203K D207	H203K P202-A	LP230	KG242K-E	KJ248L-E	KF203-E	KJ203-E	KD201LA	KJ228N	KJ238	BK239	DCX27#16x2	
	514H-7-25/BK	E248	D203K D207	H203K P202-A	LP230	KG242K-E	KJ248L-E	KF203-E	KJ203-E	KD201LA	KJ228N	KJ238	KR209	DCX27#16x2	
514H-7-25/BK-1	E248	D203K D207	H203K P202-A	LP230	KG242K-E	KJ248L-E	KF203-E	KJ203-E	KD201LA	KJ228N	KJ238	BK239	DCX27#16x2		
401M-6/TW	E237	D219K	P506-A	LP226	KG253K-E	KJ247L-E	KF203-E	KJ206-E	KD201L	TW201				DCX27#14x1	
516M-8-35/GA	E213	D204K D207	H205K P508J-A	LP226	KG253K-E	KJ247L-E	KF203-E	KJ206-E	KD201L	KJ236N	KJ219	KR219	KR219	DCX27#14x2	
516M-8-35/GA/P	E213	D204K D207	H205K P508JP-A	LP226	KG253K-E	KJ247L-E	KF203-E	KJ206-E	KD201L	KJ236N	KJ219	KR219	KR219	DCX27#14x2	
516M-8-55/GA	E214	D205K D207	H206K P509J-A	LP226	KG255K-E	KJ247L-E	KF203-E	KJ206-E	KD201L	KJ236N	KJ219	KR219	KR219	DCX27#14x2	
516M-8-55/GA/P	E214	D205K D207	H206K P509JP-A	LP226	KG255K-E	KJ247L-E	KF203-E	KJ206-E	KD201L	KJ236N	KJ219	KR219	KR219	DCX27#14x2	
516L-2-24	E215	D206 D207	H207 P500J-A	LP225	KG252K-E	KJ247L-E	KF203-E	KJ206-E	KD201L	KJ236N	KJ219	KR219	KR219	DCX27#14x2	
516L-2-24/CTE	E215	D206 D207	H207 P500J-A	LP225	KG252K-E	KJ247L-E	KF203-E	KJ206-E	KD201L	KJ236N	KJ219	KR219	KR219	DCX27#14x2	
516L-2-35	E216	D206 D207	H212 P504K-A	LP225	KG253K-E	KJ247L-E	KF203-E	KJ206-E	KD201L	KJ236N	KJ219	KR219	KR219	DCX27#14x2	
516M-3-35	E269	D208K D207	H208K P504K-A	LP226	KG253K-E	KJ247L-E	KF203-E	KJ206-E	KD201L	KJ236N	KJ219	KR219	KR219	DCX27#11x2	
516M-3-35/PS	E227	D208K D207	H214K P504JS-A	LP226	KG253K-E	KJ247L-E	KF203-E	KJ206-E	KD201L	KJ236N	KJ219	KR219	KR219	DCX27#14x2	
516M-3-35/ECA-U	E217U	D208K D207	H214K P504J-A	LP226	KG253K-E	KJ247L-E	KF203-E	KJ206-E	KD201L	KJ236N	KJ219	KR219	KR219	DCX27#11x2	
516M-3-35/ECB-U	E217U	D208K D207	H214K P504J-A	LP226	KG253K-E	KJ247L-E	KF203-E	KJ206-E	KD201L	KJ236N	KJ219	KR219	KR219	DCX27#11x2	
516M-3-35/CTE	E217U	D208K D207	H214K P504J-A	LP226	KG253K-E	KJ247L-E	KF203-E	KJ206-E	KD201L	KJ236N	KJ219	KR219	KR219	DCX27#11x2	
516M-3-35/ECA	E269	D208K D207	H208K P504K-A	LP226	KG253K-E	KJ247L-E	KF203-E	KJ206-E	KD201L	KJ236N	KJ219	KR219	KR219	DCX27#11x2	
516M-3-35/ECB	E269	D208K D207	H208K P504K-A	LP226	KG253K-E	KJ247L-E	KF203-E	KJ206-E	KD201L	KJ236N	KJ219	KR219	KR219	DCX27#11x2	

SIRUBA PARTS LIST	Series	Parts Group	Subclass / Remark	Page
	700L	BKF1		1/8
				Date
				2022/04/15

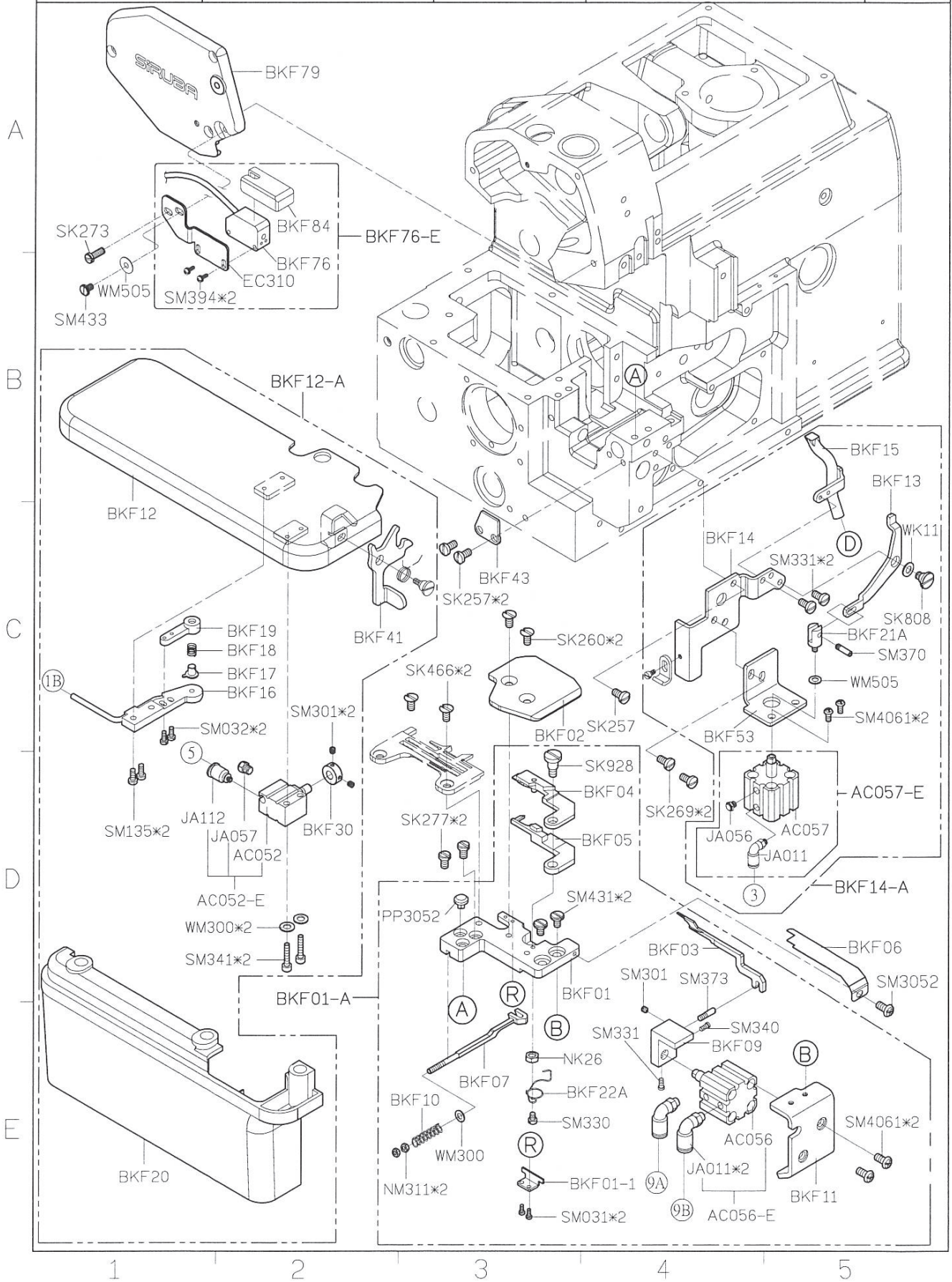

SIRUBA PARTS LIST	Series	Parts Group	Subclass / Remark	Page
	700L	BKF1		3/8
				Date
				2022/06/16

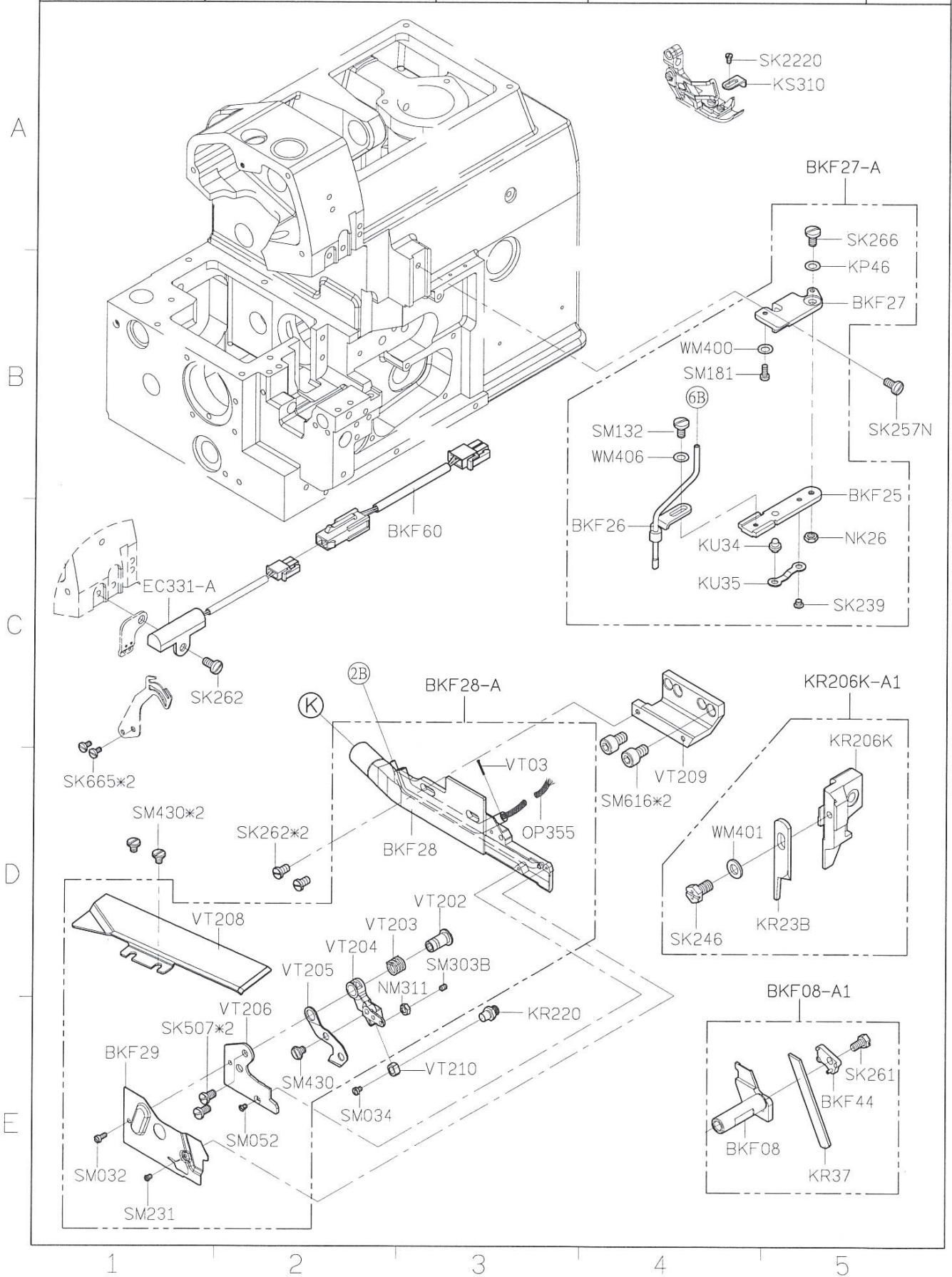

SiRUBA PARTS LIST	Series	Parts Group	Subclass / Remark	Page
	700L	BKF1		4/8
				Date
				2022/04/15

A

B

C

D

E

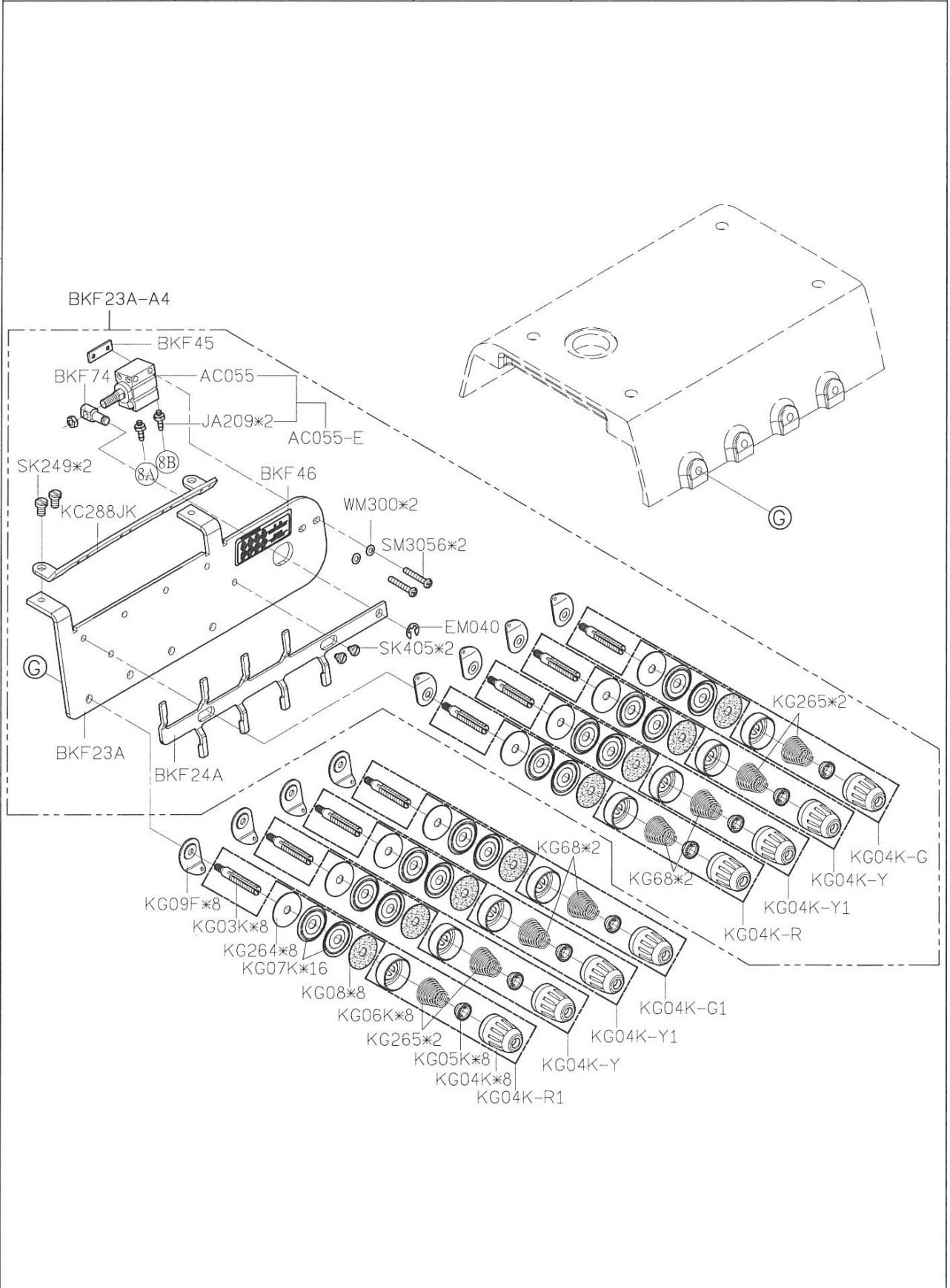

1

2

3

4

5

SIRUBA PARTS LIST	Series	Parts Group	Subclass / Remark	Page
	700L	BKF1		5/8
				Date
				2022/04/15

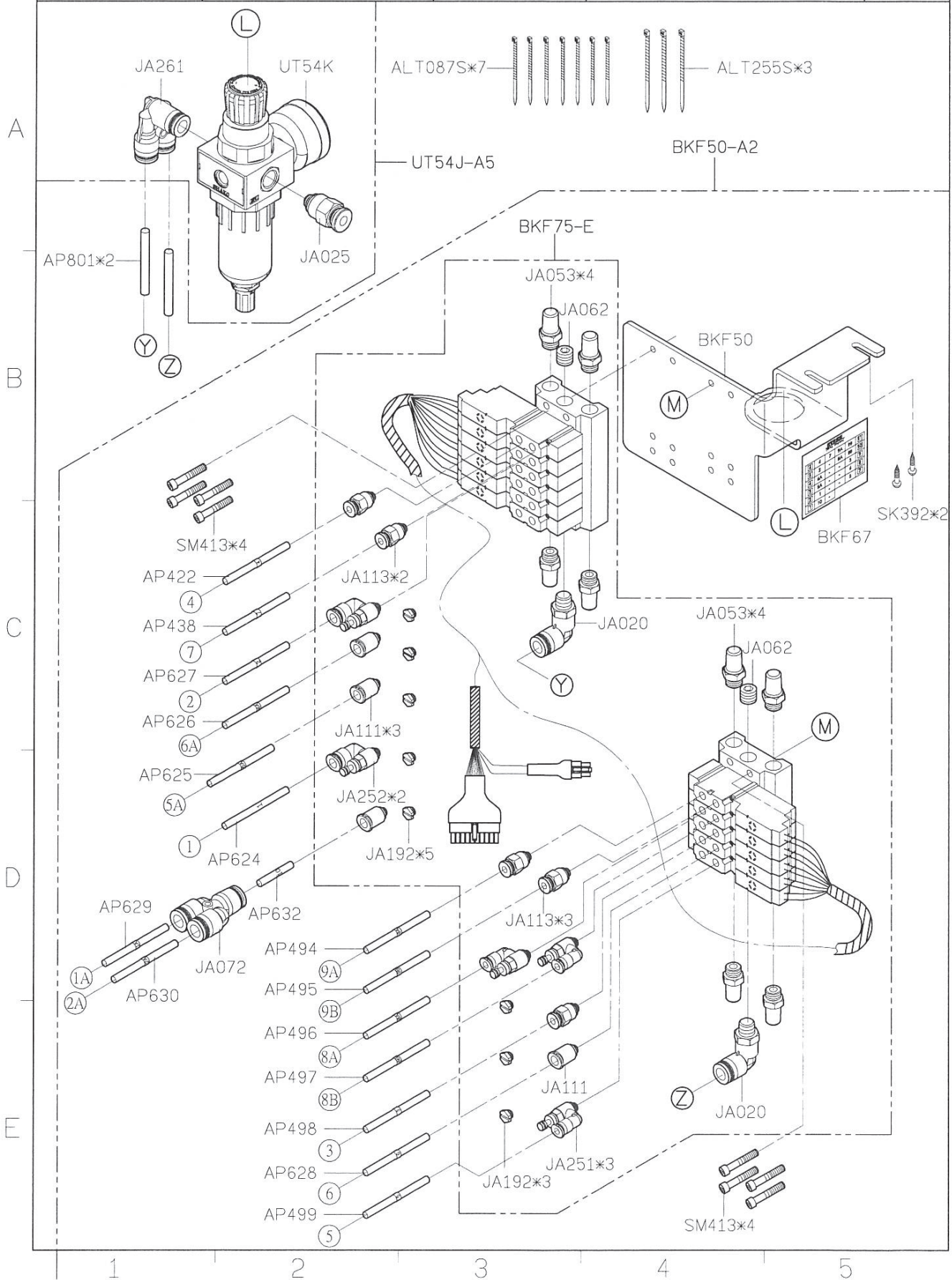

SiRUBA PARTS LIST	Series	Parts Group	Subclass / Remark	Page
	700L	BKF1		6/8
				Date
				2022/04/15

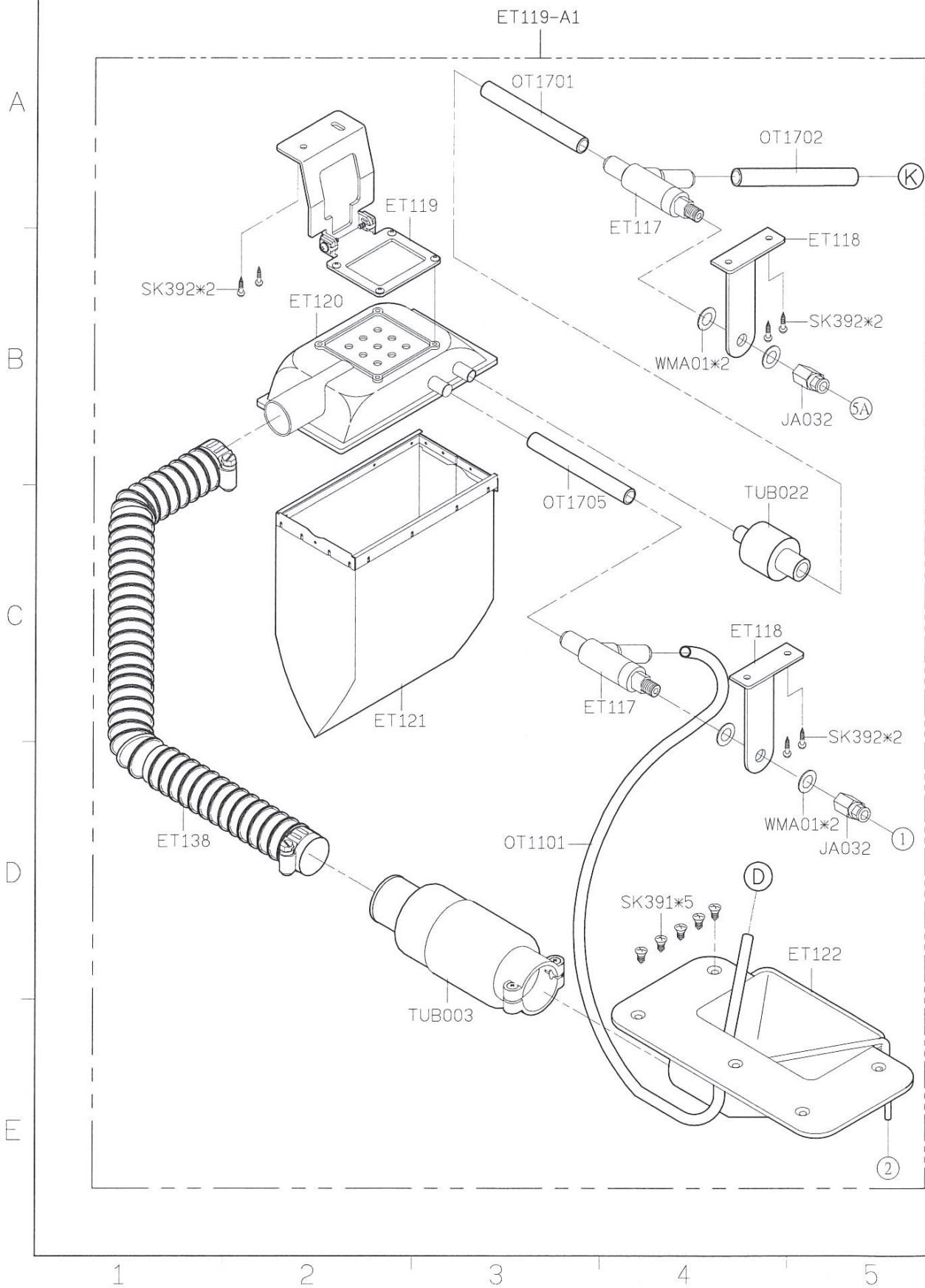

SIRUBA PARTS LIST	Series	Parts Group	Subclass / Remark	Page
	700L	BKF1		6/8
				Date
				2022/04/15

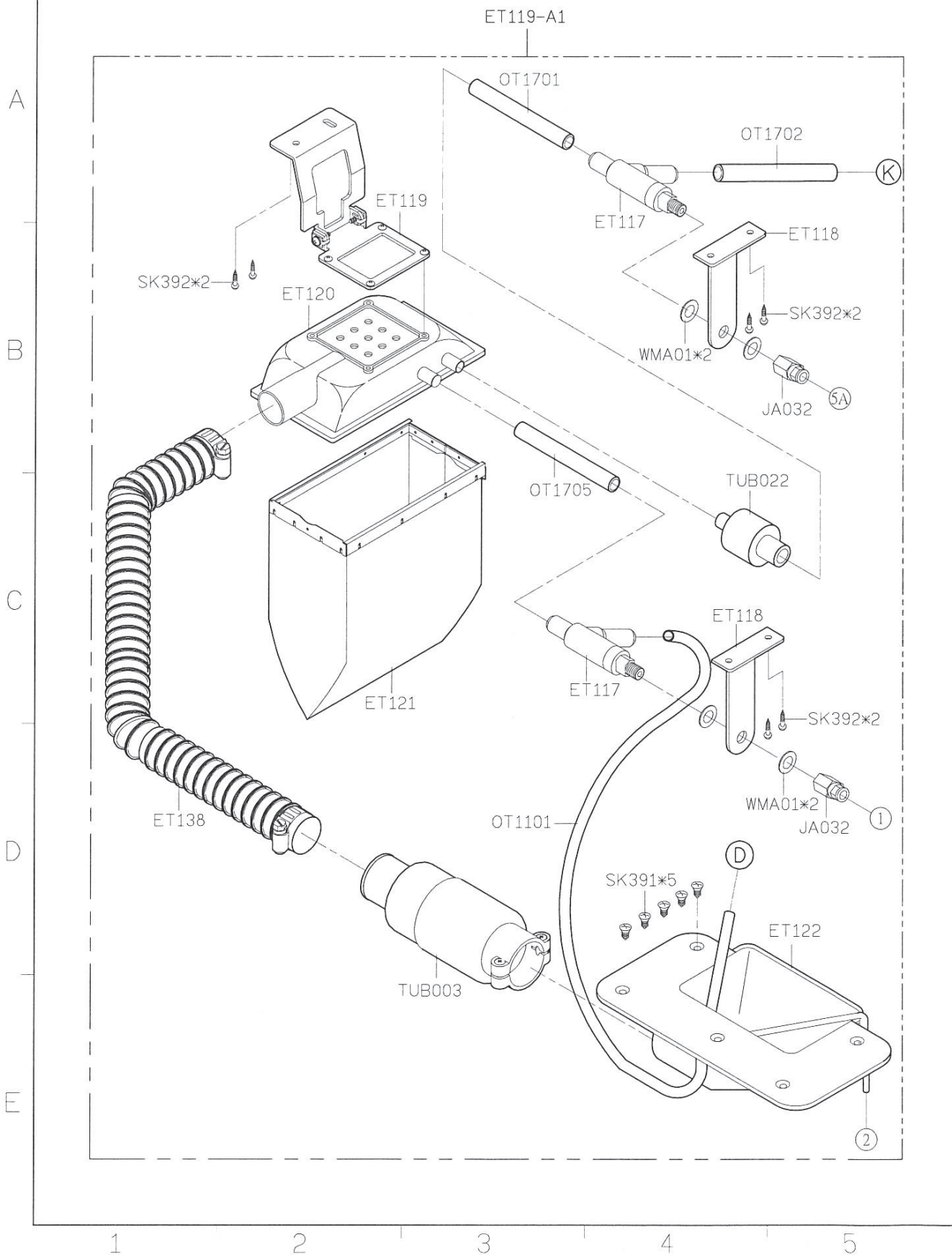

SIRUBA PARTS LIST	Series	Parts Group	Subclass / Remark	Page
	700L	BKF1		7/8
				Date
				2022/04/15

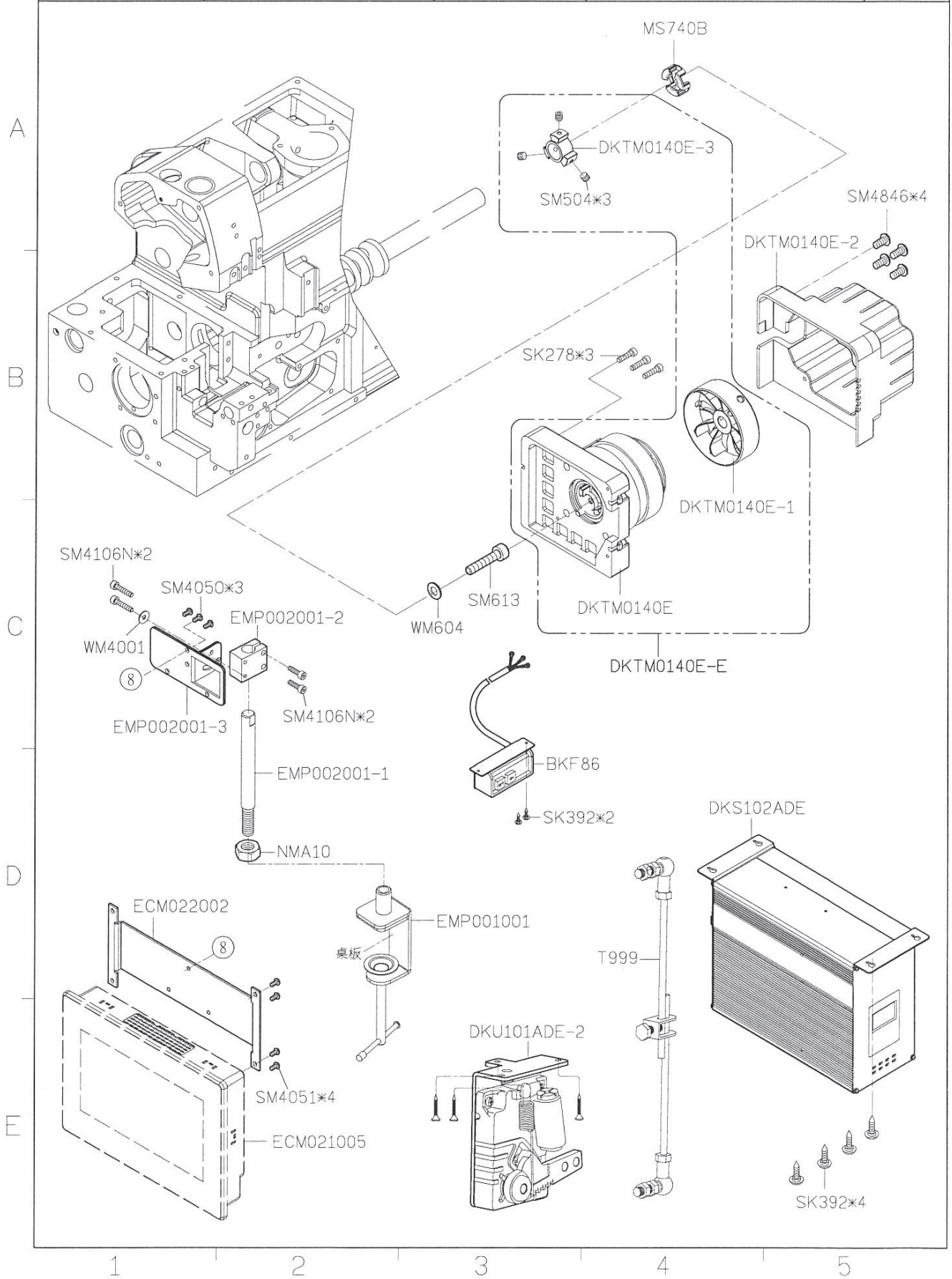

SIRUBA PARTS LIST	Series	Parts Group	Subclass / Remark	Page
	700L	BKF1		8/8
				Date
				2022/04/28

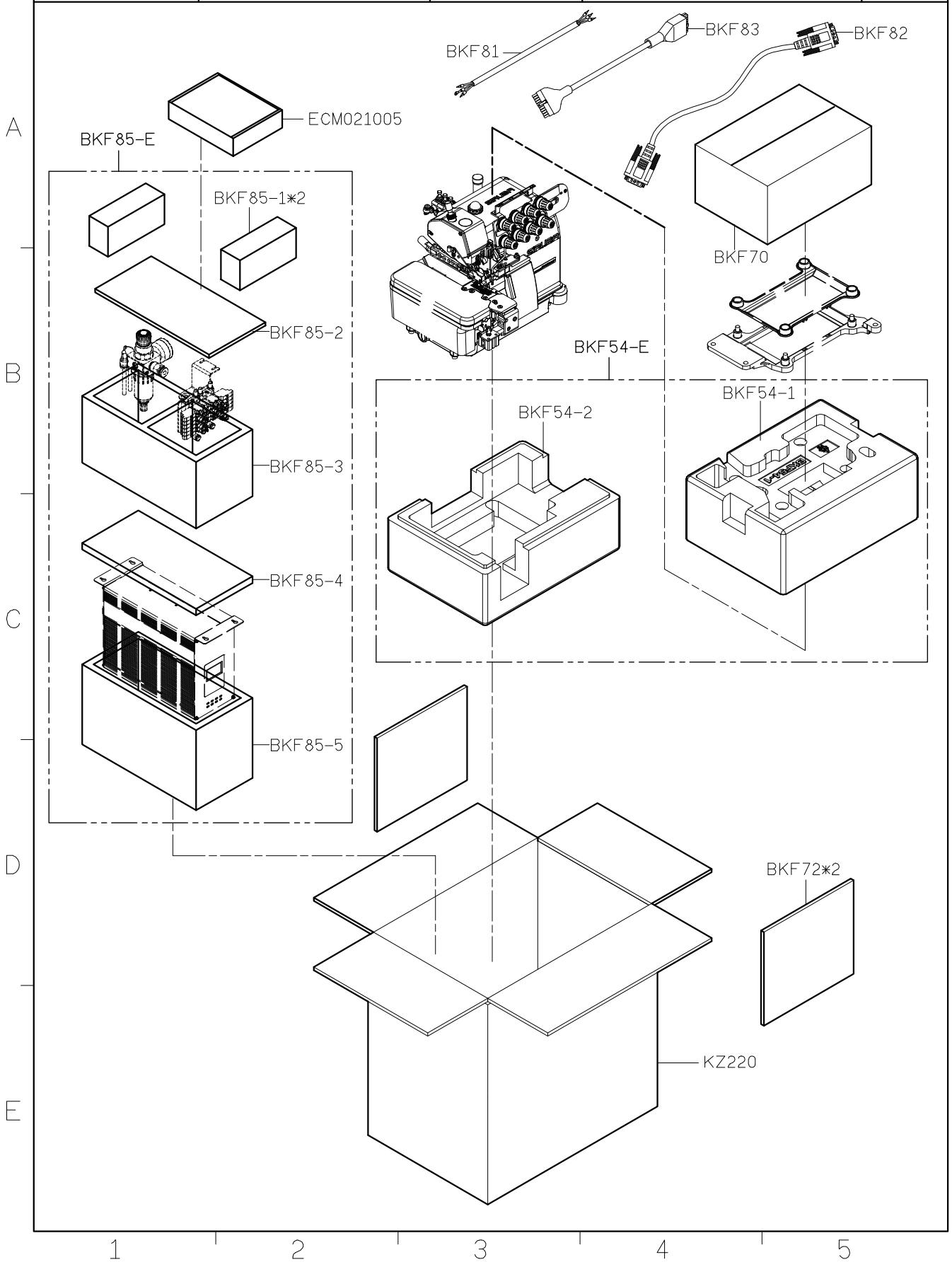

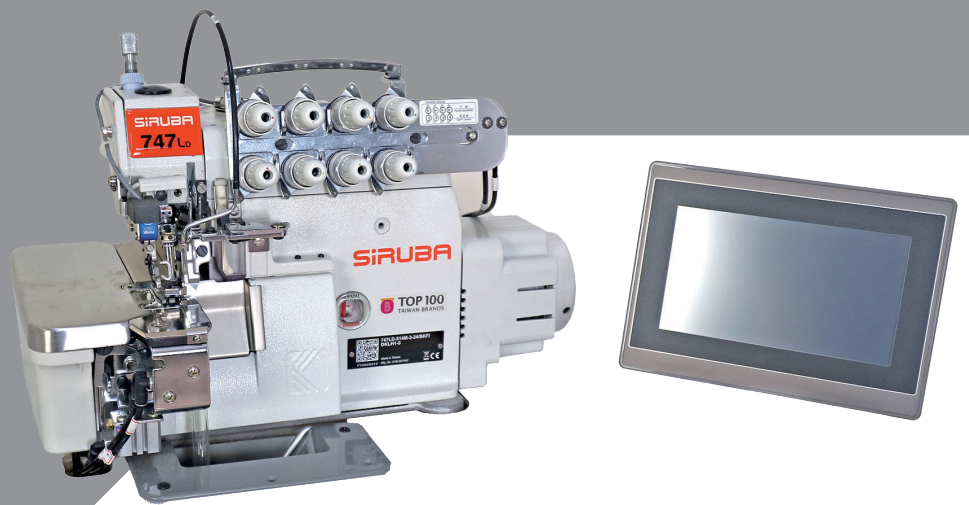

高林股份有限公司
KAULIN MFG. CO., LTD.

由於對產品的改良及更新，本產品使用說明書中與零件圖之產品及外觀的修改恕不事先通知！
The specification and/or appearances of the equipment described in this instruction book & parts list are subject to change because of modification which will without previous notice.
BKF156.SEP.2022