

# SIRUBA®

銀箭牌工業用縫紉機

INDUSTRIAL SEWING MACHINE

# 700Q/988Q

## 使用說明書 INSTRUCTION BOOK

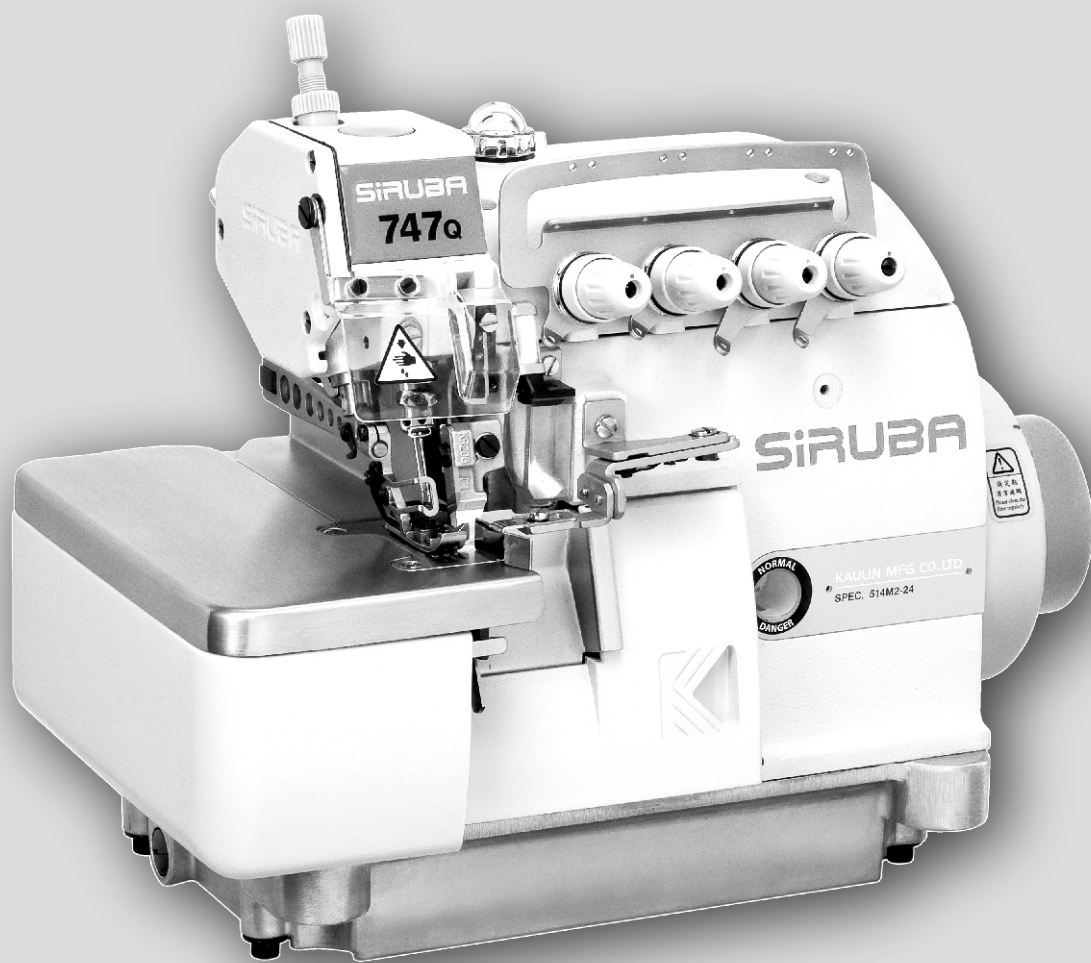



CE





高林股份有限公司  
KAULIN MFG. CO., LTD.



## 危險水準的說明 Explanation of Dangerous Level

 危險 Dangerous	<p>如果忽視此標記而運行了錯誤的機械操作, 保養時肯定會引起當事者或第三者人員重傷或死亡</p> <p>Don't ignore the warning sign and don't proceed incorrect operation. Or it will cause the person or the third party seriously injured or dead during maintenance.</p>
 注意 Caution	<p>如果忽視此標記而運行了錯誤的機械操作, 保養時有可能會引起當事者或第三者人員受傷及造成設備損壞</p> <p>Ignoring this warning sign and proceed incorrect operation will cause the person involved or the third party wounded and equipment damaged during maintenance.</p>

## 警告圖案表示及表示標幟的說明 Explanation of Warning Signs and Labels

警告圖案表示 Warning Sign		運動部位, 謹防工傷事故 Moving part, beware of industrial accident
		高壓部位, 謹防觸電事故 High voltage, beware of electric shock
		高溫部位, 謹防燙傷事故 High temperature, beware of burns
指示標誌 Instruction Label		禁止 Prohibited
		地線的接線表示 Indication of ground wiring



索引	INDEX	頁/PAGE
一般安全事項說明	GENERAL SAFETY INSTRUCTIONS	1
重要安全事項說明	IMPORTANT SAFETY INSTRUCTIONS	3
特別事項	WARNING	7
警告標籤	WARNING TAG	7
護針安全圖說	SAFETY ILLUSTRATION OF THE NEEDLE GUARD	8
搬運縫紉機	MOVING THE SEWING MACHINE	9
縫紉機的安裝位置	THE INSTALLATION POSITION	9
規格	SPECIFICATION	10
各部件名稱	NAMES OF MAJOR PARTS	12
安裝	INSTALLATION	13
照明設備	LIGHTENING EQUIPMENT	15
新機器啟用規定	HOW TO OPERATE THE NEW MACHINE	16
潤滑油之注入與更換	LUBRICATION AND DRAINAGE	16
穿線方法	THREADING	18
控線調整	ADJUST THREAD TENSION	20
換針方法	REPLACE THE NEEDLE	23
針距調整	ADJUST THE STITCH LENGTH	23
差動比調整	ADJUST THE DIFFERENTIAL FEED RATIO	24
更換切刀	REPLACE THE TRIMMERS	26
包邊寬度調整	ADJUST THE HEM WIDTH	27
針高度之調整	ADJUST THE NEEDLE HEIGHT	28
押具調整	ADJUST THE PRESSER FOOT	28
送具調整	ADJUST THE FEED DOG	30
針與勾針之關係	THE RELATIONSHIP BETWEEN NEEDLE AND LOOPER	31
環勾針運動量之調整	ADJUST THE CHAINSTITCH LOOPER MOVEMENT AMOUNT	34
濾網清潔	FILTER CLEANING	35

**索引****INDEX****頁/PAGE**

電眼感測器調整	ADJUST ELECTRIC EYE SENSOR	35
電眼自動感應切線系統	ELECTRIC EYE AUTOMATIC SENSOR	37
控制箱使用說明	CONTROL BOX SPECIFICATION	37
控制箱調整	CONTROL BOX SETTING	38
操作環境照明	LIGHTENING OF THE OPERATION ENVIRONMENT	42
操作者條件	CONDITION OF ALL OPERATORS	43
保養	MAINTENANCE	43
故障檢修	TROUBLESHOOTING	44
控制箱故障排除	CONTROL BOX TROUBLESHOOTING	50
桌板圖	TABLE CUT-OU	53
報廢流程	DEMOLITION PROCEDURE	57

### **警告！**

當使用這台機器，基本安全預防應恆被遵守，以減輕火災、電擊、或是個人傷害的風險。包含以下注意事項。

在操作這台機器之前，請閱讀所有說明並且謹記於心。

- 1. 保持工作場所清潔**  
雜亂的環境與椅子會招引危害。
- 2. 考量工作場所環境**  
勿暴露電源於雨水之中、勿在濕氣重的地方或潮濕的場所使用機械器具。保持工作場所良好的照明。當有引發火災或爆炸危險時，勿使用電源工具。
- 3. 防範於電擊危害**  
避免身體接觸地線或是接地表面。(即：管線，發熱物體，以及冷凍庫)
- 4. 勿使孩童接近**  
不要讓訪客碰觸工具或是延伸管線
- 5. 適當的穿著**  
不要穿著寬鬆衣物或穿戴珠寶，這可能被活動零件拉扯而導致危險。穿戴護髮套以包含住長髮。
- 6. 不要任意拉扯電線**  
絕不要用電線端拉扯機器，或是從插座猛拉電線來拔掉電線。使電線遠離熱源、油類或是尖銳物品。
- 7. 謹慎保養機器**  
遵從指示來添加潤滑油或是更換附件。定期檢測工具用線，如果有所損害，請使用合格的維修器具來修復。

### **Warning!**

When using this machine, basic safety precautions should always be followed to reduce the risk of fire, electric shock and personal injury, including the followings. Read all these instructions before operating this product and save these instructions.

- 1. Keep work area clean**  
Cluttered areas and benches cause injuries.
- 2. Consider environment's safety**  
Do not expose power to rain. Do not use machine tools in damp or wet locations. Keep work area well lit.  
Do not use power tools where there is risk to cause any fire or explosion.
- 3. Guard against electric shock**  
Avoid body contact with earthed or grounded surfaces (e.g. Pipes, radiators, ranges refrigerators.)
- 4. Keep children away**  
Do not let visitors touch the tool or extension code.
- 5. Dress properly**  
Do not wear loose clothing or jewelry, they may be caught in moving parts. Wear protecting hair covering to contain long hair.
- 6. Do not abuse the cord**  
Never carry the machine by cord or yank it to disconnect it from the socket. Keep the cord away from heat, oil, and sharp object.
- 7. Maintain machine with care**  
Follow instructions for lubrication and changing accessories. Inspect tool cord periodically. If damaged, have it repaired by an authorized service facility.

## 8. 分開機器

當不使用機器時、維修前、以及更換配件時。

## 9. 避免誤啟動

不要以手指置於啟動開關上之後，搬運一個已插入電源的工具。確定在插電之前，電源開關是關閉的。

## 10. 檢查損害零件

在進一步使用器具之前，應該小心檢查並確認損傷的零件或是穿戴保護器具來確認零件會正確運轉並且呈現應有功能。

## 11. 警告

除了在這本使用說明手冊中建議的功能之外，任何附件或是配件的使用，都可能會導致個人傷害的危險。

## 12. 由合格人員來修理事具

所有的修理工作應該由合格的人員使用原始個別零件來作修理。

## 連接電源的特別警示

1. 只可與有"CE"認證的按壓啟動裝置連接這台機器。
2. 遵守此使用說明手冊來安裝控制裝置。
3. 在操作過程中，永遠保持機器適當的接地。
4. 在調整、更換零件、或是維修保養之前，必須確定將插頭由插座拔出，以預防任何機器意料之外的啟動而造成危害。

## 8. Disconnect machine

When not in use, before servicing and when changing accessories.

## 9. Avoid unintentional starting

Do not carry a plug-in tool with a finger on the switch. Ensure the power switch is off when plugging in.

## 10. Check damaged parts

Before further use of the tool, a guard or other part that is damaged should be carefully checked to determine that it will operate properly and perform its intended function.

## 11. Warning

The use of any accessory or attachment, other than those recommended in this instruction manual, may present a risk of personal injury.

## 12. Have your tool repaired by a qualified person

Repairs should only be carried out by qualified persons using original spare parts.







## SPECIAL WARNING FOR ELECTRIC CONNECTION!

1. Incorporate this machine only with "CE" certificate hold-to-run control device.
2. Follow the instruction manual device to install control device.
3. Always earth machine appropriately during operation.
4. Before adjustment, parts change or servicing must be sure to pull out the plug from socket to prevent the hazard of unintentionally start of machine.









## 重要安全事項說明

恭喜您購買本機器, 為了使這台機器能獲得最佳功能以及安全的操作, 務必請正確的使用這台機器, 使用前請仔細閱讀使用說明書, 希望您能長期使用它。請記得將此說明書放在容易取得的地方。

-  1. 當您使用機器時, 除了以下事項外, 請注意其他基本安全措施。
-  2. 使用機器前, 除了這本使用說明書外, 請詳細閱讀其他有關說明書。此外, 請妥為保存這本使用說明書, 以便需要時可以隨時取閱。
-  3. 先確認機器是符合貴國安全規定及標準後, 再使用機器。
-  4. 當機器完成操作準備時, 所有安全配備必需安裝就緒, 在缺少所述安全配備下操作是不被允許的, 以免導致人員受傷。
-  5. 此機器應由受過適當訓練之操作員操作。
-  6. 為了安全, 我們建議您配戴安全眼鏡。
-  7. 以下情形, 請先關閉電源或拔掉插頭:
  - (1) 穿針線、線導片、天平等以及更換梭子時,
  - (2) 更換針、押具、針板、送具、頂針片、喇叭、車布導板, 以及其他附屬配件時。

## IMPORTANT SAFETY INSTRUCTIONS

For operating safely and getting the best functions of this machine, you must operate it correctly. Please read and follow the instructions of this manual, and keep it at hand for future references. We are confident that you will enjoy this machine as much as we enjoy manufacturing it.

-  1. Instead of the following instructions, when you use this machine, please pay attention to the basic safety measures.
-  2. Before using this machine, please read this manual and all related instructions. In addition, please keep this manual for future needs.
-  3. Before using this machine, please ascertain that it conforms with safety standards and regulations of your country.
-  4. When the machine is ready for operation, all the safety equipments must be ready. Operate this machine without the specified safety devices is not allowed.
-  5. This machine must be operated by a properly trained operator.
-  6. For your own safety, we suggest you wearing goggles.
-  7. Please turn off the power switch or disconnect it for any one of the circumstances of the followings:
  - (1) When threading needle(s), adjusting thread Take-up(s), thread guide(s), and / or replacing bobbin(s),
  - (2) When replacing needles, presser feet, needle plates, feed dogs, needle guards, horns, cloth guides and other parts or accessories,

- (3) 維修工作時。
- (4) 離開工作場所或工作場所無人看顧時。
- (5) 若使用離合器馬達而無煞車片裝置時，必需待馬達完全停止。



8. 假如不慎讓機器及配件使用之油或油脂, 接觸到眼睛、皮膚或誤食時, 請立刻以水清洗接觸部位及就診。



8. If grease, oil, or any fluid contacts your skin or eyes by any chance, please wash the contacted area completely with clean water and consult a doctor. Or, swallow any fluid mistakenly, consult a doctor immediately.



9. 請勿擅自碰觸運轉中之零件或配件及注意機器電源是否已開啟，以免導致人員受傷。



9. Do not touch any functioning parts and devices. Always attend to whether power switch is on or off before operating in order to prevent anyone from getting hurts.



10. 維修、修改及調整等工作，需由受過適當訓練的技師或熟手為之。維修時只許使用指定之零件。



10. Qualified technicians are required for adjustment, modification, and repair. Only use assigned parts for replacement.



11. 一般維修及檢查工作必須由受過適當訓練的人員為之。



11. Routine maintenance and service must be performed by well trained persons , or qualified technicians.



12. 電子零件維修及保養工作必須由資深的電子技師為之，或由非常熟練的人員檢查及指導，當發現零件損壞時，請立刻停止機器運轉。



12. Maintain and check the electronic parts must be done by qualified electrician or well-trained persons. If any electronic part damaged or malfunctioned, stop the machine immediately.



13. 在做裝有氣動式零件(例如氣缸)機器的維修及保養工作前，機器連接空壓機及高壓空氣必須予以關閉及卸除，機器中殘存高壓氣體必需予以消除，此外調整及性能檢查只能由受過適當訓練的技師或熟手為之。



13. The air hose has to be detached from the machine and the compressor or air supply has to be cut off before repairing and servicing the machine equipped with pneumatic parts such as an air cylinder. Qualified technicians or well-trained persons are required for adjustment and repairs.





14. 機器使用一段時間，必需定期清理。



14. To ensure the best performance, periodically clean the machine is necessary.

 15. 為使機器能正常操作及減少噪音，機台務必平放地上，機器避免在強烈噪音的環境下操作

 16. 選用適當的電源插頭，並由電子技師將其按裝在機器上，且插頭必需插在有接地線的之插座上。

 17. 機器只允許被使用於指定用途上，其他用途是不允許的

 18. 修改或變更機器必需依照安全規定及標準，同時採取有效的安全措施，本公司不承擔任何因私自修改或變更機器所引起損壞之責

19. 警告標誌以兩種符號標示：

 (1) 對操作員或服務人員之傷害危險，也為了避免觸電之危險，請勿打開馬達電器箱之外蓋，也不要觸摸電器箱裡面之零件

 (2) 必需特別注意事項  
a. 絕對不可在移開皮帶蓋，手指保護蓋或安全配件後，進行機器操作，以免導致人員受傷

 b. 為了避免被機器纏住，當機器運轉中，您的手、頭髮及衣服，需遠離手輪，皮帶及馬達；此外這些部位周圍不可放置任何物品，以免導致人員受傷

 15. In order to operate properly and to reduce the noise, please place the machine flat and level on the ground. Avoid operating the sewing machine at a noisy surrounding.

 16. Select a proper power plug and install it by an electrician. Please connect the power plug to a grounded receptacle.

 17. This machine can only be used for the designed purpose. Other uses of this machine are not allowed.

 18. Any modification or conversion made on this machine must be conformed with the safety standards and regulations. Precaution is necessary. No responsibility will our company take for damages caused by any modification or conversion of this machine without permission.

19. Two safety warning signs are applied as warning signs:

 (1) For the safety of operators and service persons, please don't open the cover of any electronic control boxes of motor or other devices and don't touch any components inside to avoid electrical shock hazards.

 (2) Always keep in mind :  
a. Please never operate this machine without belt cover, finger guard or any safety device to avoid physical injury.

 b. Please keep your hair, fingers and cloths away from the hand wheel, V belt and motor while the machine is in operation, as well as never put anything near these parts, to prevent the risk of injuries by tangled into them.



c. 當您打開電源開關後或機器已在運轉中，絕不可將您的手放在針的下方或針線控線桿外蓋中，以免導致人員受傷。



c. Please never put your fingers under the needle(s) or in the thread take-up cover to prevent physical injuries when you turn on the power switch or operate the machine.



d. 當機器運轉中，梭頭高速轉動，為了避免對手可能引起之傷害，必需確定您的手保持遠離梭頭附近。此外，當更換梭子時，確定電源開關已關閉，以免導致人員受傷。



d. While the machine is in operation, the hook rotates at a high speed. Please keep your hands away from the area of hook to prevent any potential injury to your hands. In addition, please make sure to turn off the power of the machine while changing bobbins.



e. 當放置或抬起機頭時，小心勿將手置於機器中，以免導致人員受傷。



e. Be careful and do not place your fingers inside the machine when placing or lifting the machine head to avoid possible physical injuries.



f. 為了避免機器突然啟動而引起可能意外，當機頭傾斜或移開皮帶蓋及皮帶時，請關掉機器電源，以免導致人員受傷。



f. Please turn off the power before tilting the machine head or removing the belt cover and the V belt to avoid possible accidents due to abrupt start of this machine.



g. 如果您的機器是配置伺服馬達，機器於靜止狀態時，馬達是不會產生噪音的，為了避免機器突然啟動而引起可能意外，故請關掉機器電源。



g. For machines equipped servo motors, the motors do not produce noise while the machines are at rest. Therefore, please turn off the power of this machine to avoid possible accidents due to abrupt start of the machine.



h. 為了避免觸電之危險，請絕不要在移開電源接地線後操作機器。



h. Never operate the sewing machine after the ground wire is removed to avoid electrical shock hazards.









- i. 為了避免觸電或電子零件損壞而引起之可能意外，請先切斷電源，再插上或拔掉插頭。



- i. Please turn the power switch off before connecting or disconnecting the power plug to prevent possible accidents due to electric shock or damaged electronic components.

## 特別事項

為了避免機器故障及損壞，請先確定以下事項：

1.  當您安裝好機器後，做第一次機器操作前，請徹底清潔機器。
2.  清除運送途中累積之灰塵及溢出之油脂。
3.  確定電壓及馬達相數(單相或三相)安裝正確。
4.  確定電源插頭正確地接上電源。
5.  當使用電壓與標示電壓不同時，請勿使用機器。
6.  確定機器轉動方向是否正確。









**警告：**

在操作或調整本書中所提到之各步驟前，請先將電源關掉，以免因為機器突然啟動造成之意外。

## WARNING

Please confirm the followings to avoid malfunction or damage to this machine.

1.  After installing the machine, and before the first operation, please clean it completely.
2.  Clean all dust and overflowed oil during transportation.
3.  Confirm that the voltage and the phase (single or 3 phase) of motor are set correctly.
4.  Confirm that the power plug is correctly connected to the power supply.
5.  Never use the machine when the local voltage type is different from the marked voltage on the nametag attached on the machine.
6.  Confirm that the rotating direction of the machine pulley is correct.



**Warning :**

Before doing any operation or any adjustment described later in this manual, please turn the power off to prevent accidents caused by abrupt start of the sewing machine.

## 警告標籤

- 縫紉機上有下列警告標籤。(圖1)
- 當使用縫紉機時，請遵守標籤上的說明。如果標籤脫落或模糊不清，請和購買商店聯繫。

## WARNING TAG

- The following warning tags will be attached on the sewing machine. (Fig. 1)
- When using the sewing machine, please follow the instructions of the tags. Please contact the dealer if any of the tags is fallen off or fuzzy.



圖1/Fig. 1

• 安全防護裝置及轉動方向(圖2)

• Safety protection device and Safety protection device.(Fig.2)

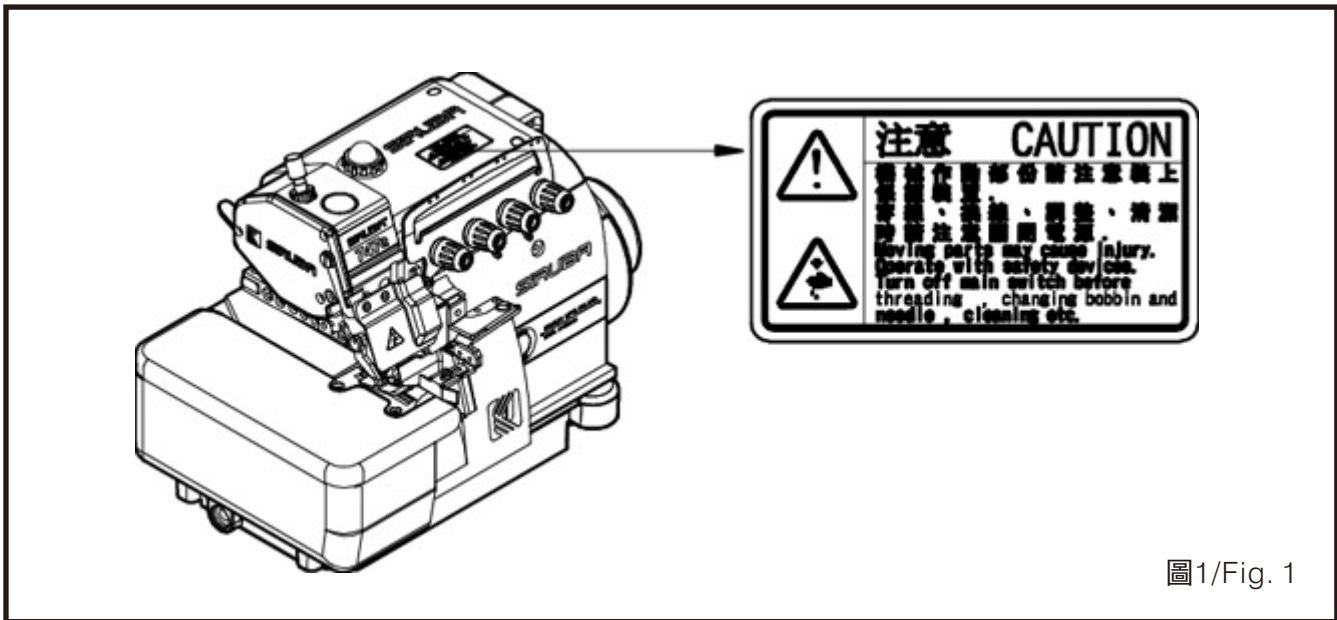

圖2/Fig. 2

護針安全圖說

SAFETY ILLUSTRATION OF NEEDLE GUARD

本縫紉機之押具防護裝置如圖所示，為保護操作者之操作安全，嚴禁將此裝置拆卸。

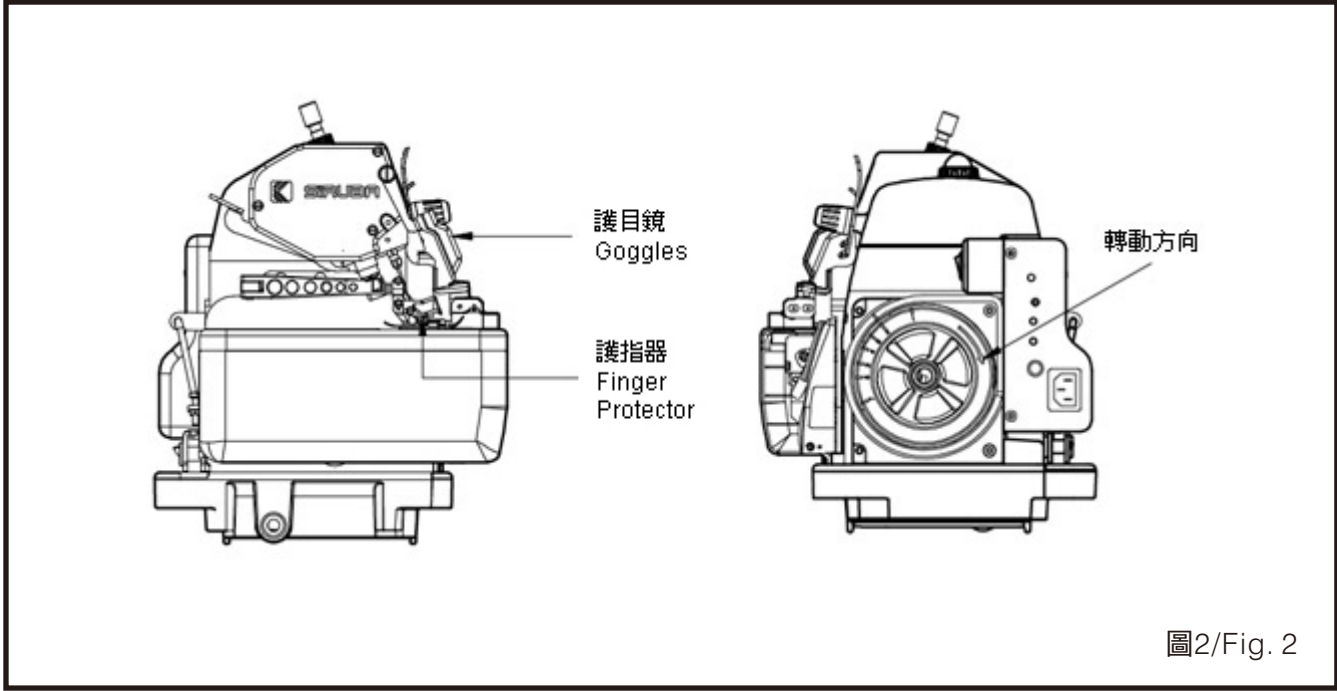
The presser foot protection device is as shown as the figure 3. For safety of all operators, this device is restricted to disassemble.



圖3/Fig. 3

## 搬運

縫紉機之搬運，應按圖示用左手托住前機殼本體，右手撐扶住底盤進行搬運。搬運時須穿著安全鞋。(圖4)

## MOVING THE SEWING MACHINE

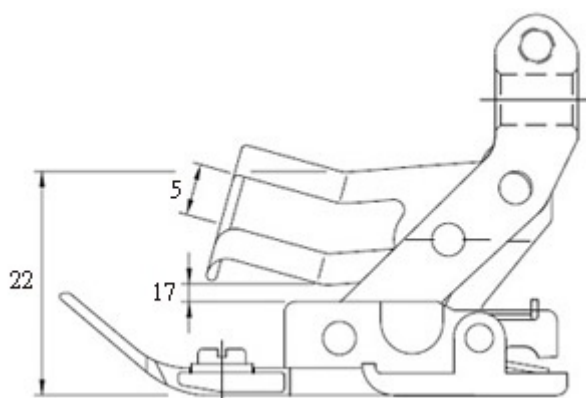
To move the sewing machine, please follow the figure shows. Using left hand to hold the front machine cover body, and right hand to hold the bottom plate to move. Please wear safety shoes while moving. (Fig.4)



圖4/Fig. 4

## 關於縫紉機的安裝位置

1. 勿將該縫紉機置於設備附近，如電視機、收音機或無線電話等，否則這些設備可能被縫紉機的電子干擾所影響。(圖5)
2. 應將縫紉機直接插入AC電源插座，如果使用延長線，可能會造成機能失常。

## THE INSTALLATION POSITION OF THE SEWING MACHINE

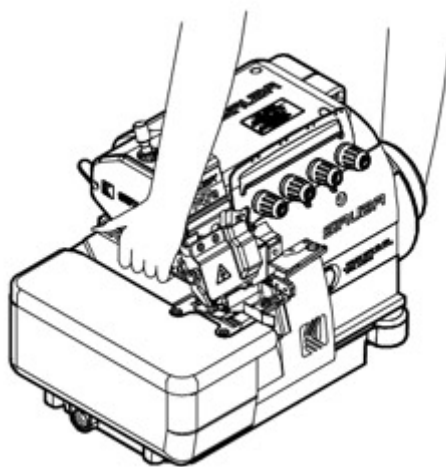
1. Please do not install the sewing machine near the equipments, such as Television, Radio, or Wireless Telephone. Or these equipments will experience electronic interference. (Fig. 5)
2. The wire should insert to the AC power socket directly. If using the extension wire, this might cause malfunction.



圖5/Fig. 5

規格

SPECIFICATIONS

1.外銷型號分類：

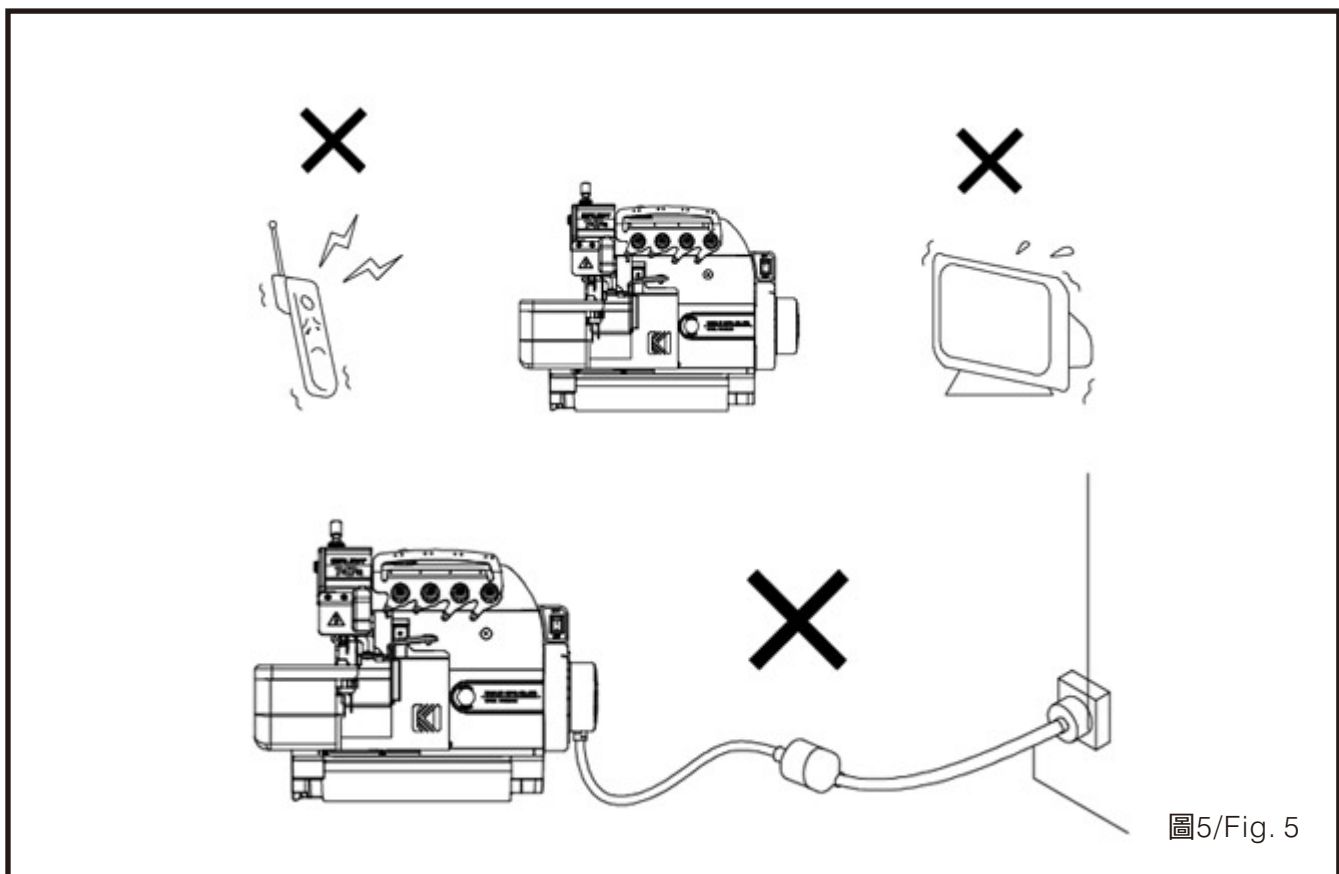
1.Description:

747 Q - 514 M 2 - 2 4 CT  
 (1) (2) (3) (4) (5) (6) (7) (8)

(1) 表示線數分 737, 747, 757, 767

(2) 機種別

(3) 縫合方式(圖表1)

(1) Thread numbers / Four types: 737, 747,

757, 767

(2) Machine type

(3) Sewing type(Chart1)

型式 TYPE	504	512	514	516	514+401
圖形 PATTERN					

圖表1/Chart1



- (4)車縫布料  
 F: 輕薄布料  
 L: 薄布料  
 M: 中厚布料  
 H: 厚布料  
 X: 特厚布料  
 (5)送具型式  
 (6)針寬  
 (7)包邊寬度  
 3: 3mm, 4: 4mm, 5: 5mm, 6: 6mm  
 (8)配件

- (4)Sewing materials  
 F: Fine weight material  
 L: Light weight material  
 M: Medium weight material  
 H: Heavy weight material  
 X: Extra heavyweight materia  
 (5)Feed dog type  
 (6)Needle width  
 (7)Seam width  
 3: 3mm, 4: 4mm, 5: 5mm, 6: 6mm  
 (8)Attachment

2.規格說明 (表1)

2.Specification (Table1)

機型 Model	700K/988Q
最高縫速 Max Stitch Speed	6000spm
噪音值 Noise Level	82分貝以下 under 82 dB
縫距 Stitch Length	4 / 5 / 6 mm
針棒行程 Stroke of the needle bar	24.3 ±0.2 mm
押具揚程 Presser Foot Lift	5.5mm
押具壓力 Presser Foot Pressure	5kg
送具高度 (凸出針板面) Feed Dog Height (over the plate)	0.7~0.9mm
使用針 Needle for Use	DCX27
送具傳動方式 Feed Dog Transmission	偏心輪、連桿 Eccentric, Connecting Rod
送具齒寬度 Teeth Width of the Feed Dog	1.6mm
縫目調整裝置 Stitch Adjusting Device	按鈕調整 Button Adjustment
押具裝置 Presser Foot Device	彈簧式、旋鈕調整式 Spring Type, Knob Adjustment Type
加油方式 Oil Filling	儲油槽儲存方式，毛氈、棉線毛細管自動供油 Oil tank storage type. Automatic oil supply by felt, cotton thread capillary action.
回油方式 Oil Return Solution	偏心泵浦 Eccentric Pump
使用油 Oil for Use	提供專用油 (MOBIL #10) Provide Specific Oil (MOBIL #10)

表1/Table1



圖6/Fig. 6

- (1) 押具扳手(圖6)
- (2) 押具
- (3) 控制箱
- (4) 線架
- (5) 油窗
- (6) 手輪

- (1) Lifting lever (Fig. 6)
- (2) Presser foot
- (3) Control box
- (4) Thread stand
- (5) Oil gauge window
- (6) Pulley (Hand Wheel)

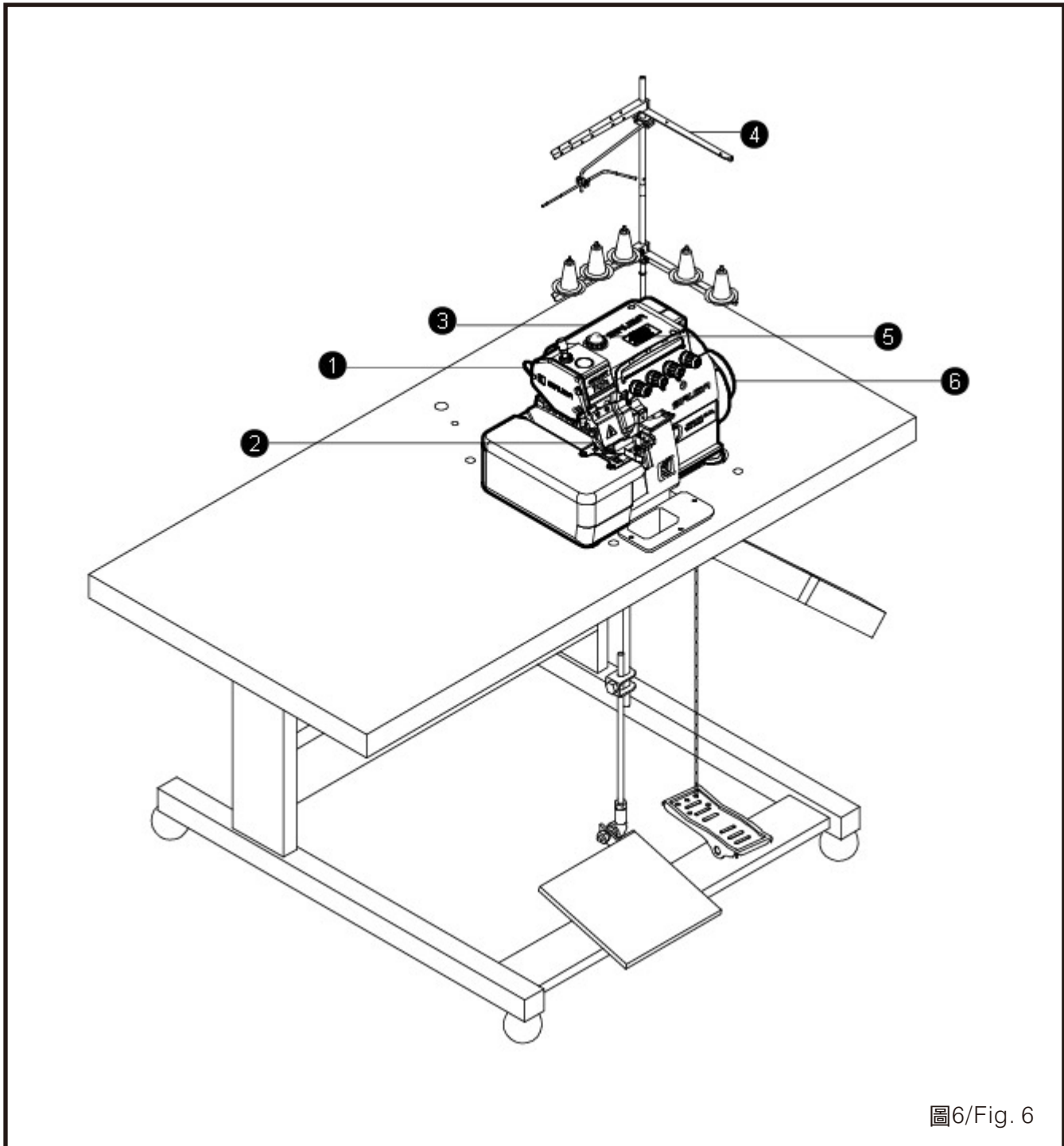

## 注意CAUTION



請讓受過培訓的技術人員來安裝縫紉機。

Machine installation should only be carried out by a qualified technician.



請委託購買商店電氣專業人員進行電氣配線。

Contact your dealer or a qualified electrician for any electrical work that may need to be done.



縫紉機重50公斤, 安裝工作必須由兩人以上來完成。

The sewing machine weighs 50kg. The installation should be carried out by two or more people.



在安裝完成前, 請不要連接電源, 如果誤按啟動開關, 縫紉機動作會導致受傷。

Do not connect the power cord until installation is complete. The machine may operate if the treadle is depressed by mistake, which could result in injury.



縫紉機頭倒下豎起時, 請用雙手進行操作。單手操作時因縫紉機的重量萬一滑落易導致受傷。

Use both hands to hold the machine head when tilting it back or returning it to its original position. If only using one hand, the weight of the machine head may be too heavy to hold, and may cause human physical injuries.

1. 縫紉機拆箱搬運過程中, 不可扶持布蓋板①下方。(圖7)

1. While moving the sewing machine after opening the box, please do not hold the below side of the cloth cover ①. (Fig. 7)



圖7/ Fig. 7

2. 依本機所附桌板裁製圖及零件組合圖所列之配件，依序安裝機板支撐架②及塑膠油盤③。(圖8)

2. Please refer to the attached table cut-out diagram and the parts list to orderly assemble the machine base supporter ② and plastic oil tank ③. (Fig.8)

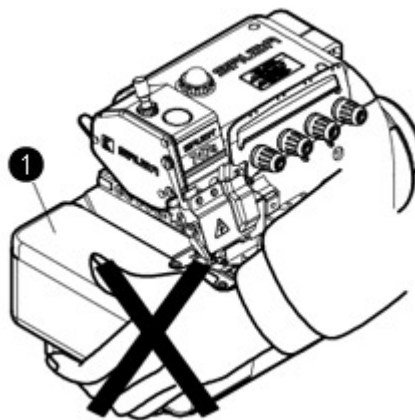
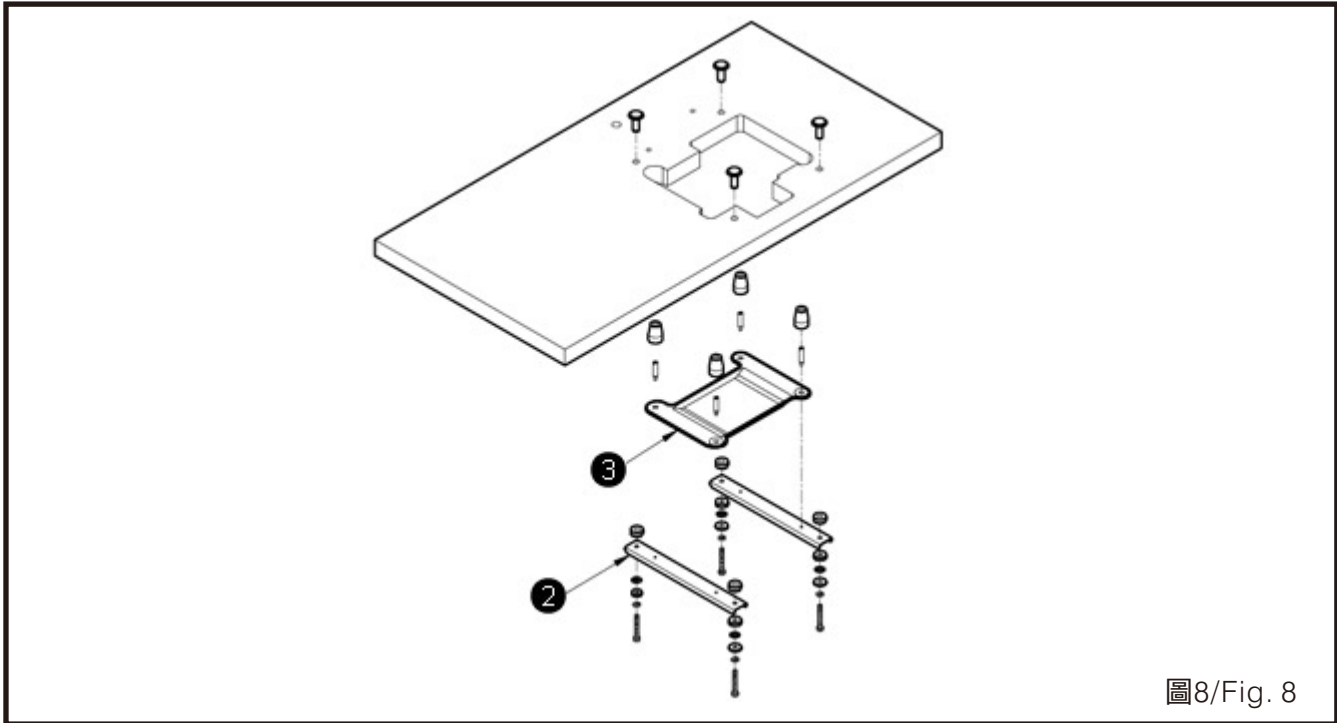

3. 裝置導布屑及線架。(圖9)

3. Assemble the waste disposal set and the thread stand. (Fig.9)

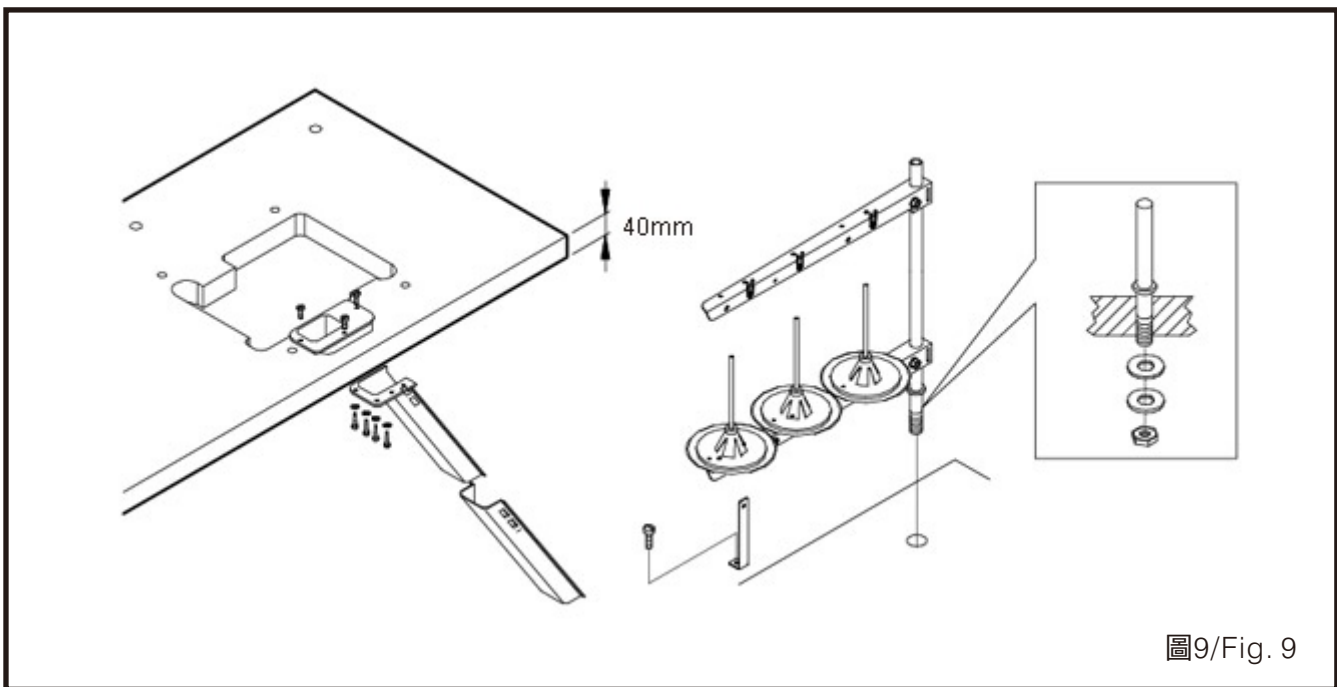

4. 馬達啟動踏板④裝於左邊，押具腳  
踏板⑤則裝於右邊。(圖10)

4. Assemble the motor starting pedal ④  
to the left side, and the presser foot  
pedal ⑤ to the right side. (Fig.10)

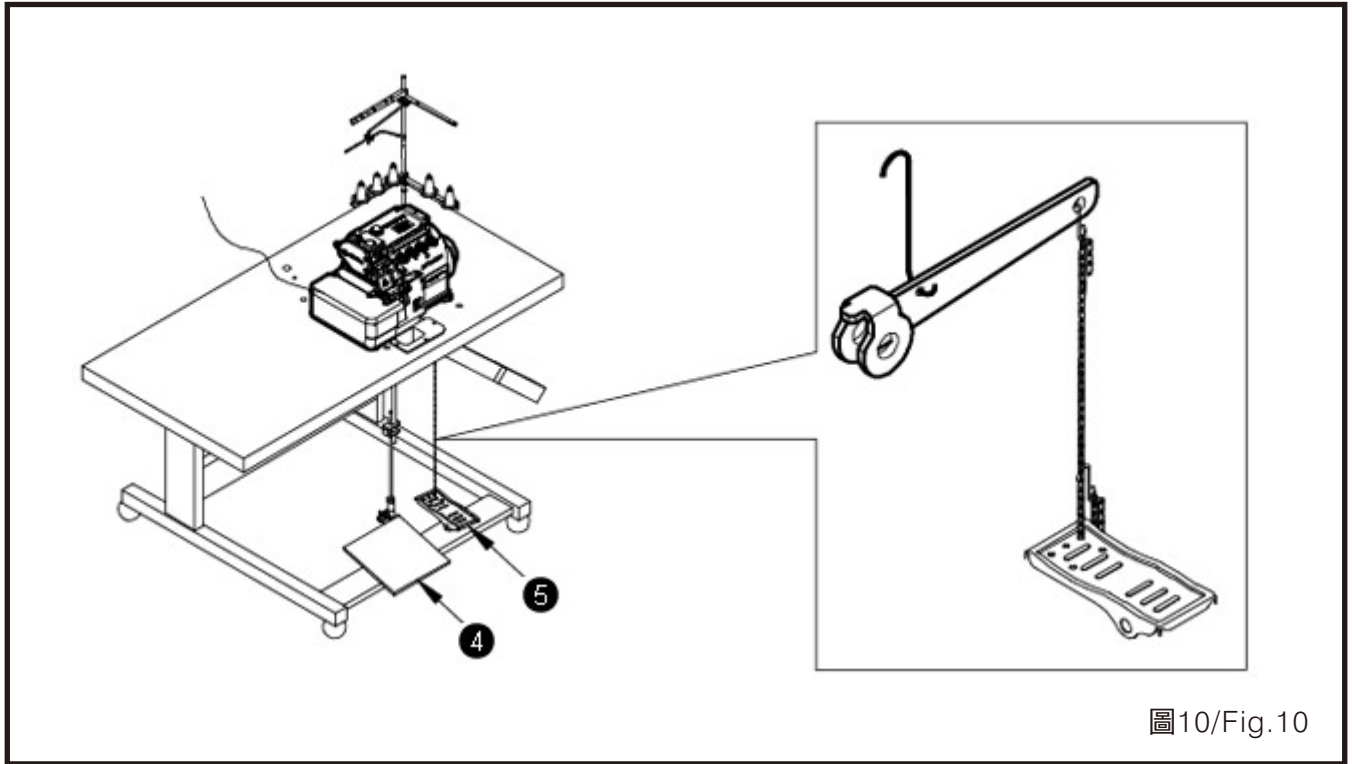

## 照明設備

## LIGHTENING EQUIPMENT

貼心使用者設計的照明機構，其採用不發熱、壽命長之發光二極體LED燈具，讓使用者能方便於穿線。(圖11)

Thoughtful lightening equipment is designed for the operators. Non-heating and long life LED lamps are adopted so that the operators can thread easily. (Fig.11)

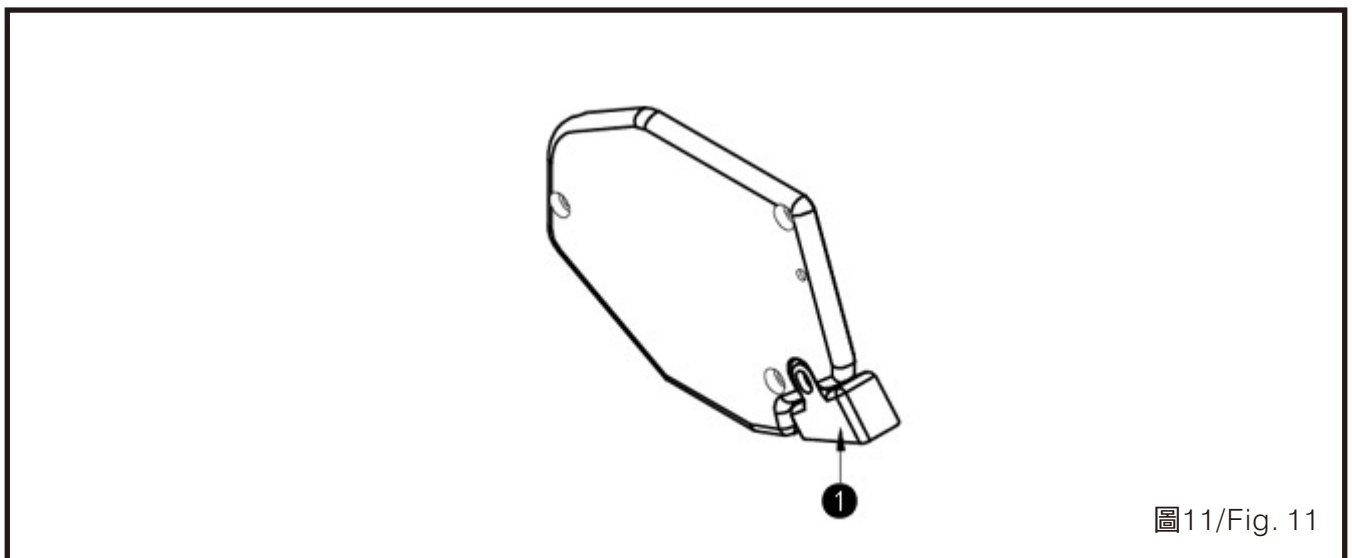

## 新機器啟用規定

1. 新機器在最初啟用磨合期的四個星期內，請用低於最高速度20%的速度運轉，之後換上新潤滑油，才可運轉至最高速度。
2. 定期之清潔保養，確保延長機器之使用壽命。

## HOW TO OPERATE THE NEW MACHINE

1. Please operate this machine in 80% of the maximum speed in the first four weeks for engagement. After four weeks, please do not operate under the maximum speed until replacing the new lubrication oil.
2. Periodically maintain and clean the machine to ensure and extend the usage term of the machine.

## 潤滑油之注入與更換

1. 潤滑油之注入(圖12)
  - (1) 螺絲 ① 旋開，以包裝箱內所附之超高速潤滑油或選用 ESSO #32 (或MOBIL #10) 等相當之機油加入，使油量指示桿位於油標上下之間即可，然後再鎖緊螺絲 ①。
  - (2) 開箱新機器或久置未使用時，請在針棒、上鉤針台等加油潤滑。

## LUBRICATION AND DRAINAGE

1. Fill the lubrication oil (Fig.12)
  - (1) Remove the screw ①, and fill it with the attached ultra high speed lubricating oil, or choose ESSO #32 (or MOBIL #10) or equivalent. Tighten the screw ① after the oil level indicator locates between the two marking lines.
  - (2) Please lubricate the needle bar and the upper looper shaft before starting operating a new machine or a long idling machine.



圖12/ Fig. 12

## 2.潤滑油之更換 (圖13)

- (1)將螺絲②放鬆旋開，使油槽內的油完全排出後再鎖緊。
- (2)為延長本機器之壽命，請於開始使用後四星期更換新油，爾後約每四個月更換一次。
- (3)為延長此機器之壽命，特別裝有濾油器之機構，請在每使用一個月後卸下清洗乾淨，必要時得更換新品。

## 2.Drainage and refill the oil (Fig. 13)

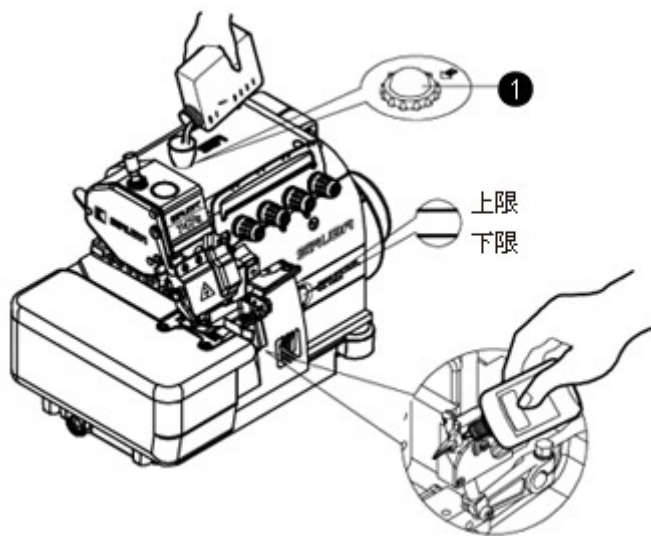
- (1)Loosen the screw ② and drain all the oil inside the oil tank. Then, tighten the screw ② again.
- (2)In order to extend the term of usage, please replace the oil after the first four week, and then replace it every four months.
- (3)To extend the usage term, this machine has equipped an oil filter. Please disassemble and clean it every month, as well as change it if needed.

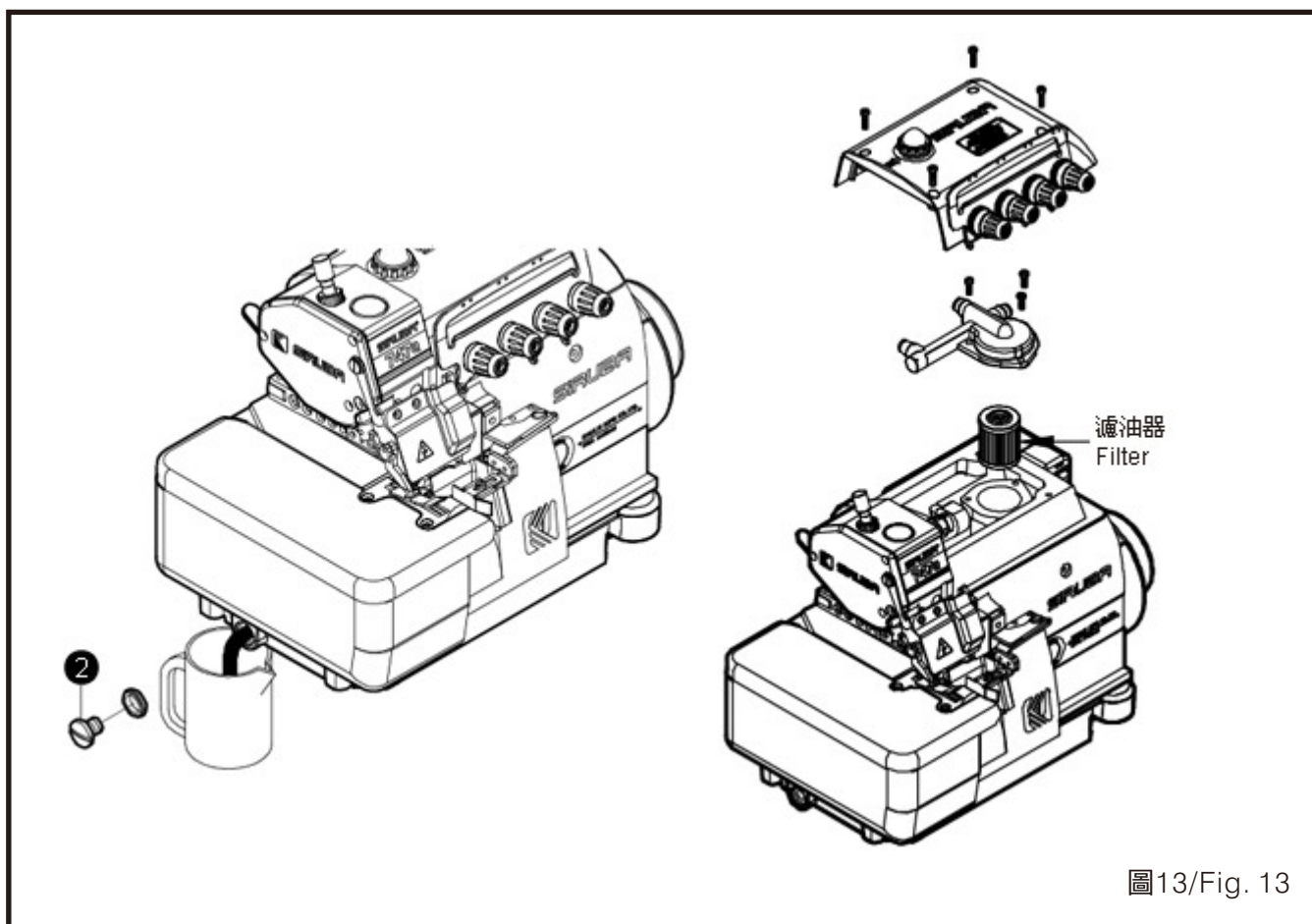

## 3.針之冷卻油使用油:矽油(圖14)

## 3.Needle cooling lubrication oil: SILICON OIL.(Fig. 14)



圖14/Fig. 14

## 穿線方法

## THREADING

請確實按照圖示穿線，錯誤之穿線將引起斷線、跳針及車縫不平坦 … 等現象。

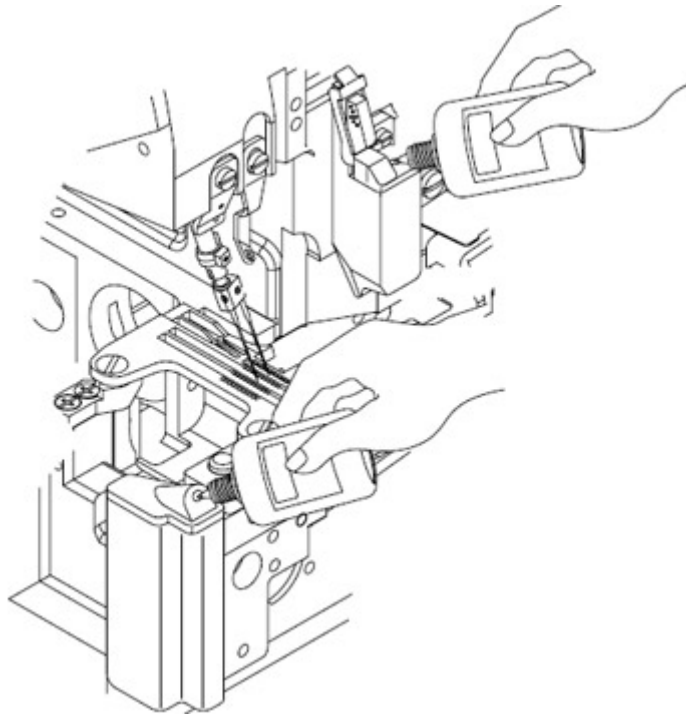
Follow the procedures for threading. Wrong threading may cause thread breaking, stitch skipping, puckering or unexpected sewing.

1. 737用穿線圖(圖15)

1. For three thread only 737 (Fig. 15)



圖15/Fig. 15



2.747用穿線圖。(圖16)

2.For four thread only 747.(Fig. 16)

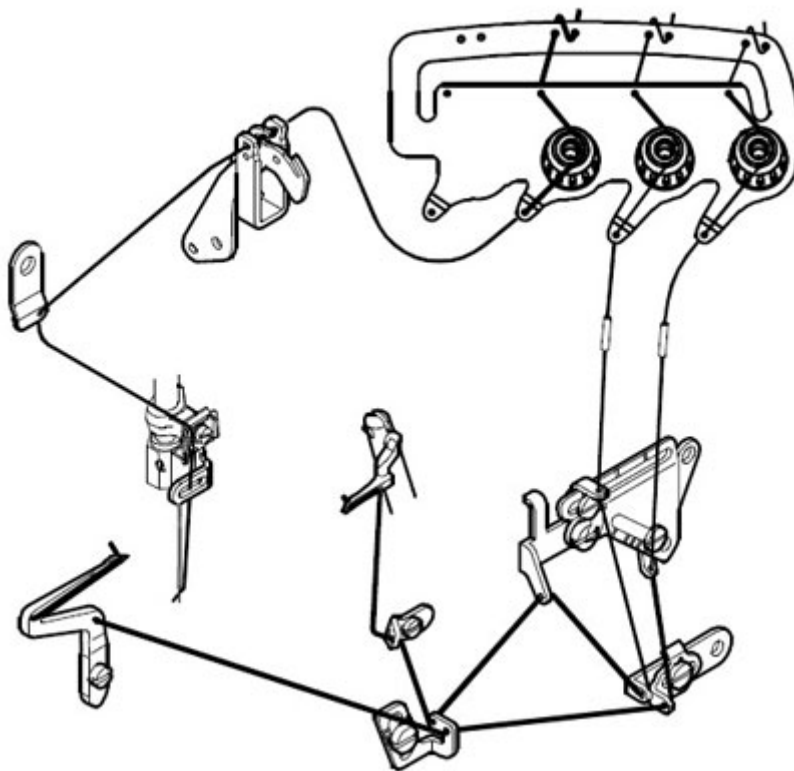
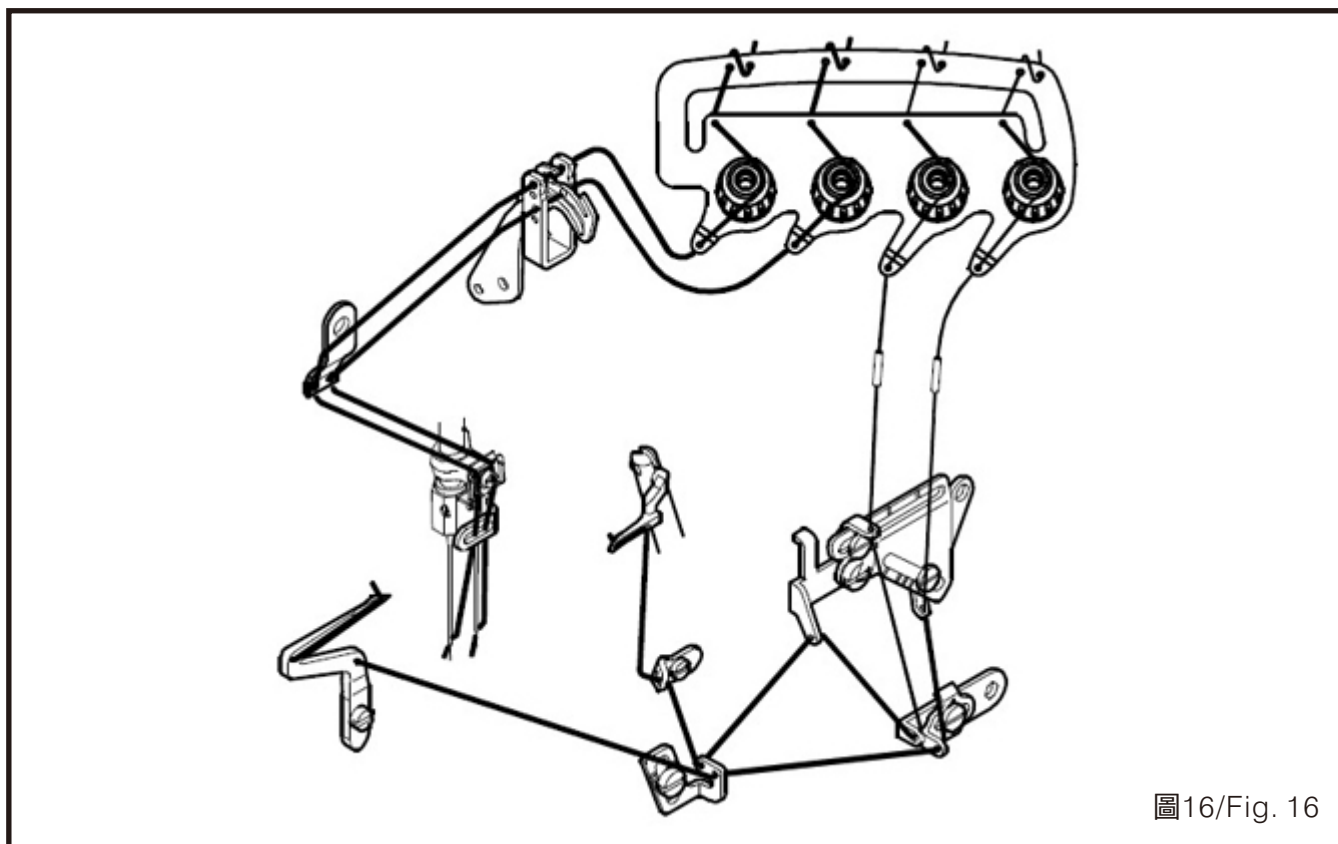

3.757用穿線圖。(圖17)

3.For five thread only 757.(Fig. 17)

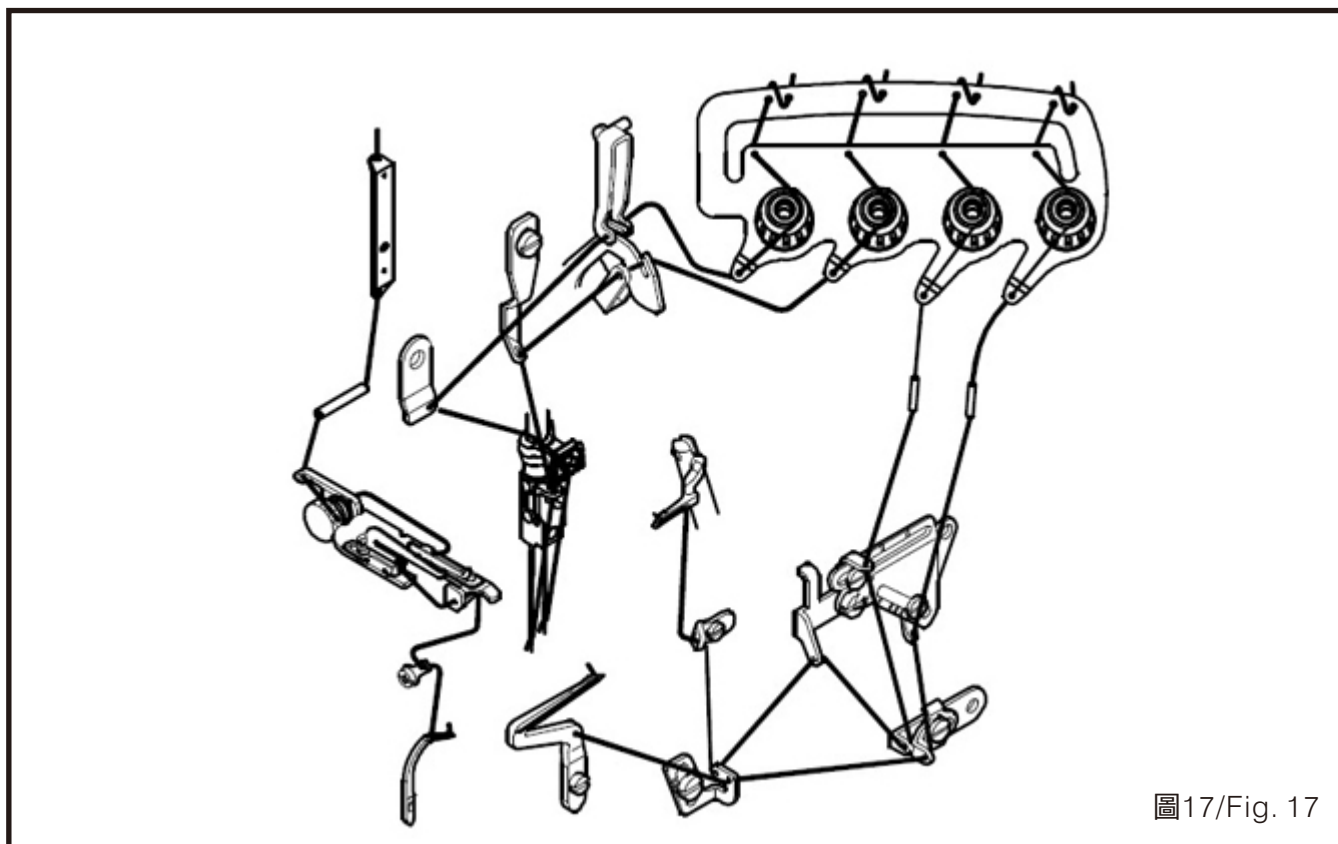



圖18/Fig. 18

## 控線調整

## ADJUST THREAD TENSION

線張力必須根據縫合布料種類，布料厚薄，線及包邊寬度等之差異而做不同的調整。順時針旋轉張力控制螺帽，縫線張力加大，反之減弱。

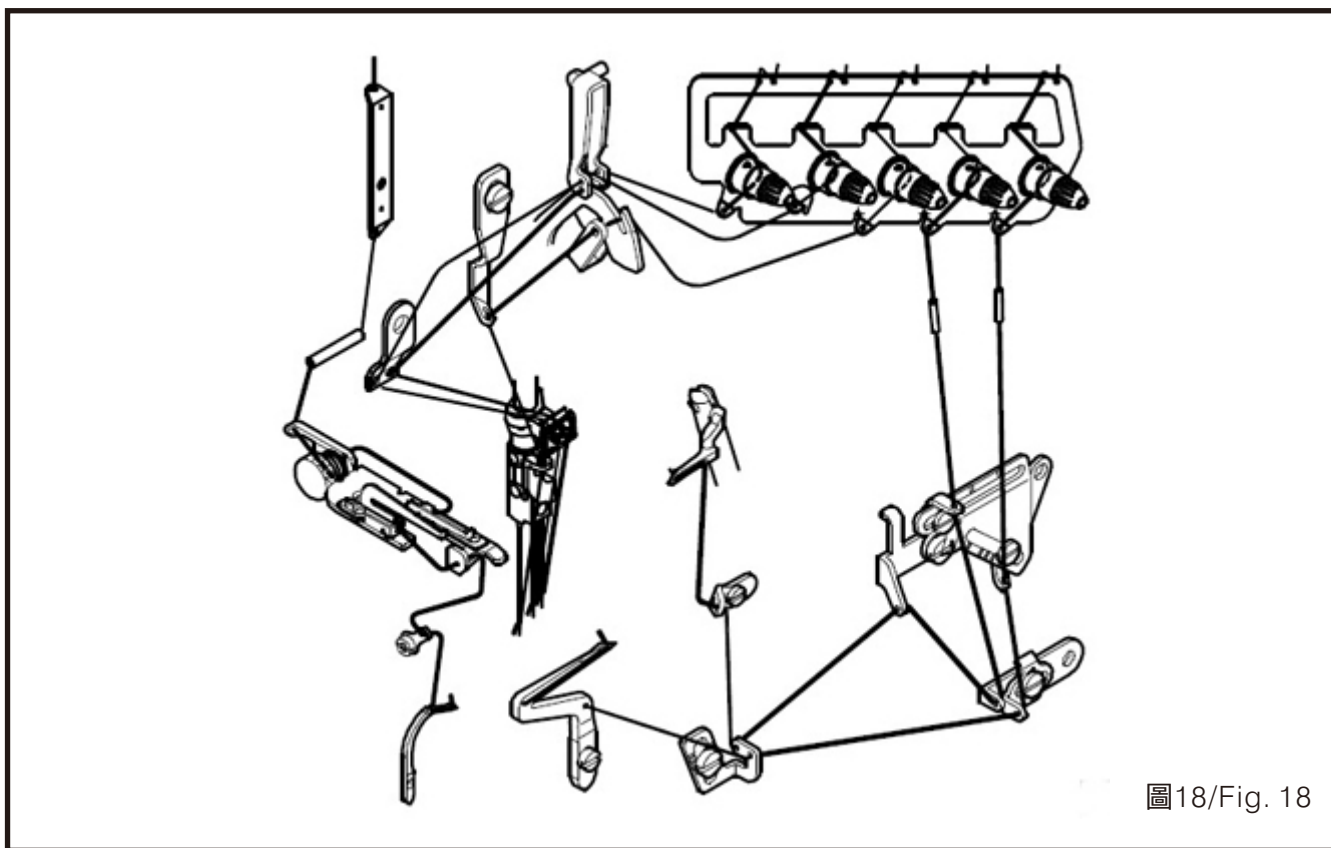
### 1. 調整鈕之控線關係(圖19)

- (1) 第一調整鈕① 控制雙環針線或左邊拷克線
- (2) 第二調整鈕② 控制包邊針線
- (3) 第三調整鈕③ 控制上勾針線
- (4) 第四調整鈕④ 控制下勾針線
- (5) 第五調整鈕⑤ 控制雙環勾針線

The thread tension should be adjusted properly according to the kinds and the thickness of the materials, stitch length, and seam width, etc. In addition, adjust the nuts case by case individually. Turn the nuts clockwise will increase the thread tension. Otherwise, the thread tension will be decreased

### 1. Thread tension adjusting nuts (Fig19)

- (1) The first adjusting nut① controls double chain stitch threads or the left over-lock needle thread.
- (2) The second adjusting nut② controls the seam lock needle thread.
- (3) The third adjusting nut③ controls the upper looper thread.
- (4) The fourth adjusting nut④ controls the lower looper thread.
- (5) The fifth adjusting nut⑤ controls the double chain looper thread.



圖19/Fig. 19

## 2. 針線控線關係(圖20)

- (1) 在縫合方式 504、512、514 時，將過線組件⑥移至最下端，縫合方式 516 時，則將過線組⑦、⑧移至最上端。
- (2) ⊕ 表示增加針線放線量
- (3) ⊖ 表示減少針線放線量。

## 2. Needle thread control(Fig20)

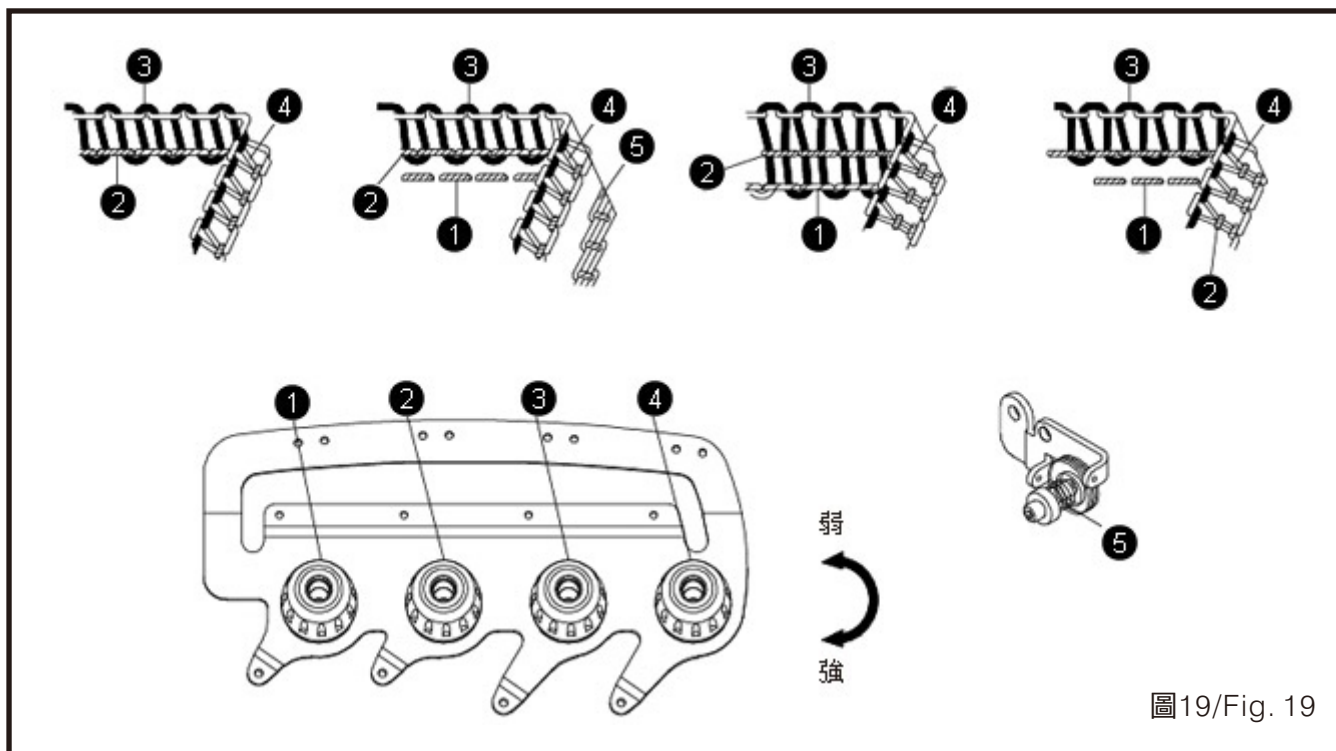
- (1) When the sewing type is set to 504, 512, or 514, move the threading part ⑥ to the lowest part. When the sewing type is 516, move the threading part ⑦ and ⑧ to the highest point.
- (2) The ⊕ direction indicates to increase the needle thread length.
- (3) ⊖ means to decrease the needle thread length.



圖20/Fig. 20

### 3. 勾針控線關係(圖21)

- (1)若縫合方式為503, 504, 505及上勾針移至最低時, 將⑨及⑩調整至⊕位置。若縫合方式為505時, 則移至⊖端。
- (2)固定線導板⑪、⑫如下: ⊕方向為縫合線較多, 反之較少。

### 3. Looper thread control (Fig.21)

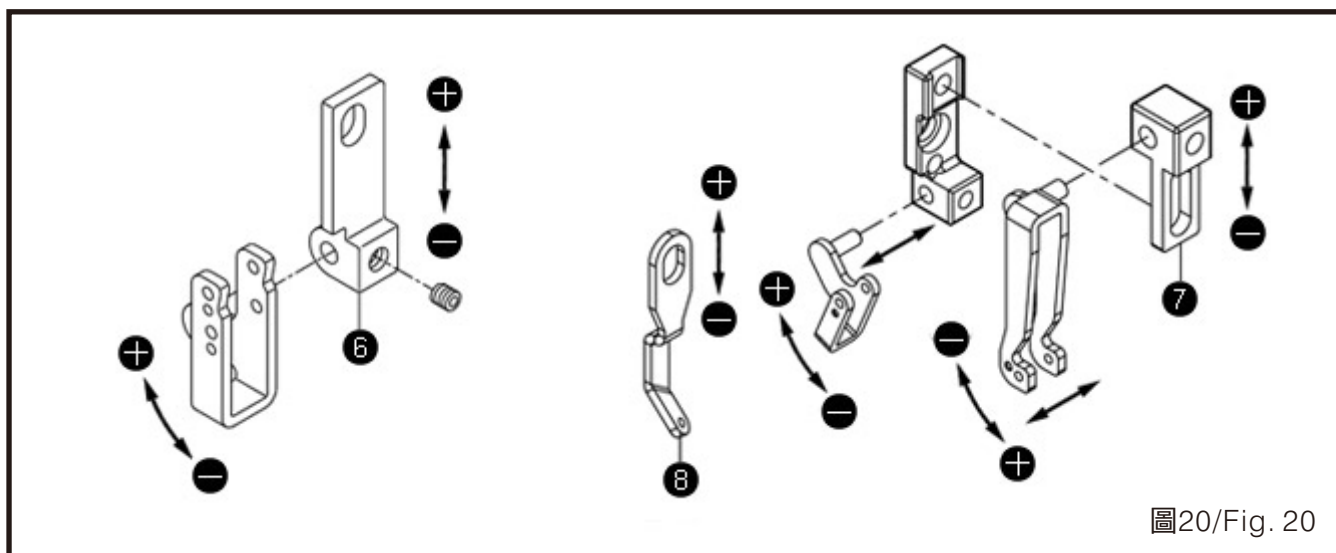
- (1)When the sewing type is 503, 504, 505, and the upper looper is on the lowest point, adjust ⑨ and ⑩ at the position of ⊕. When the sewing type is 505, set the take-up ⑨ and ⑩ at the position of ⊖.
- (2)Adjust fixed thread guide plate ⑪ and ⑫ as the following: The direction ⊕ is for more thread in sewing seam, and the ⊖ direction is for less thread in sewing seam.



圖21/Fig. 21

### 4. 環縫線凸輪控線關係(圖22)

- (1)調整線導致線環不穩定(鬆塌或成形不足)時。
- (2)⊕表示增加針線放線量。
- (3)⊖表示減少針線放線量。

### 4. Chainstitch thread cam control (Fig.22)

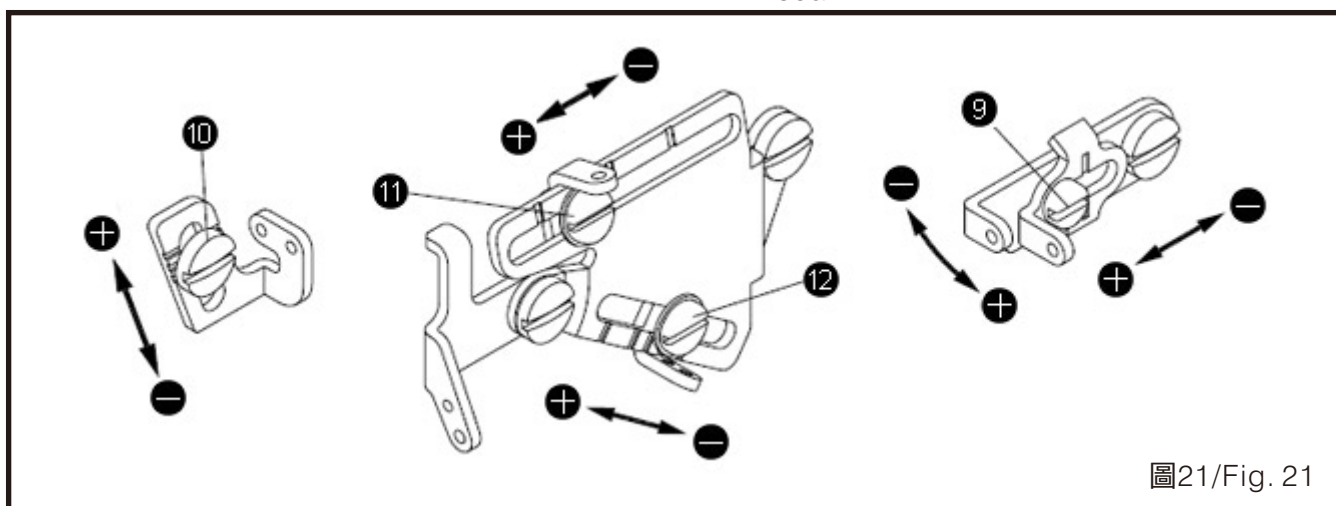
- (1)Adjusting the lower thread causes the thread ring unstable (too loose or didn't form a thread ring).
- (2)⊕ means to have more thread amount while sewing.
- (3)⊖ means to have less thread amount while sewing



圖22/Fig. 22

## 換針方法

1. 使用 DCX27 或同規格之針。
2. 旋開螺絲①並取下針。
3. 將新針插至針孔最底端，並使針之長溝面向自己，固定螺絲①。(圖23)

## REPLACE THE NEEDLE

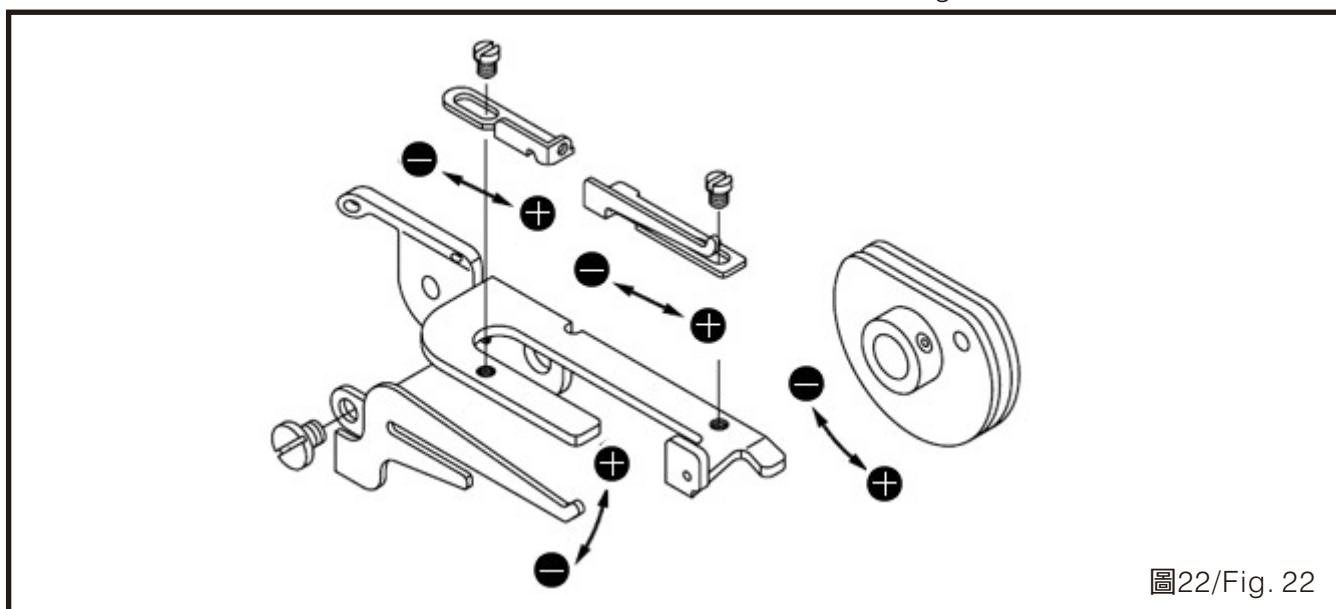
1. Please use the needle DCX27 or the equivalents.
2. Loosen the screw ① and take off the needle.
3. Insert the new needle till reaching the end, as well as the long groove faces your side. Tighten the screw ① . (Fig.23)



圖23/Fig. 23

## 針距調整

通常依縫合布料，差動比等之不同而調整。持續壓下按鈕①並轉動手輪使鈕卡住，轉動手輪至所需之針距後放開此按鈕。(圖24)(表2)

## ADJUST THE STITCH LENGTH

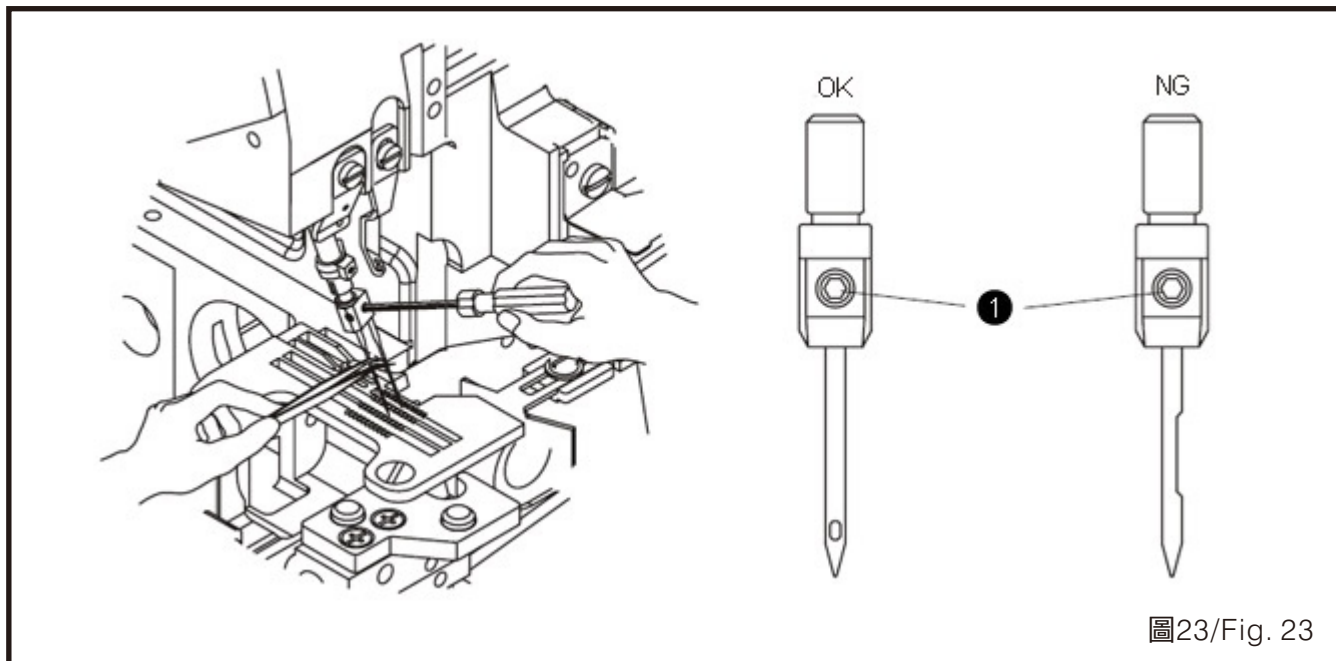
The stitch length is adjusted according to the fabrics the differential ratio or other factors. Keep pressing the button ① and turn the pulley till the button is locked. Then, release the button after reaching the desired stitch length. (Fig.24)(Table2)

Maxi Diff ratio	Machine type	Pulley scale						
		1	2	3	4	5	6	7
1:2	Seaming	0.6	1.13	1.66	2.19	2.72	3.25	3.8
1:3	Shirring	0.6	1.03	1.46	1.89	2.32	2.71	3.2
1:1.3	Serging	0.8	1.5	2.2	2.9	3.6	4.3	5
1:4	Special	0.6	1.02	1.44	1.66	2.28	2.7	-

表2/Table2



圖24/ Fig. 24

### 差動比調整

### ADJUST THE DIFFERENTIAL FEED RATIO

若主送具之運動行程大於差動送具運動行程時，布料車縫時會伸張，反之則會收縮。

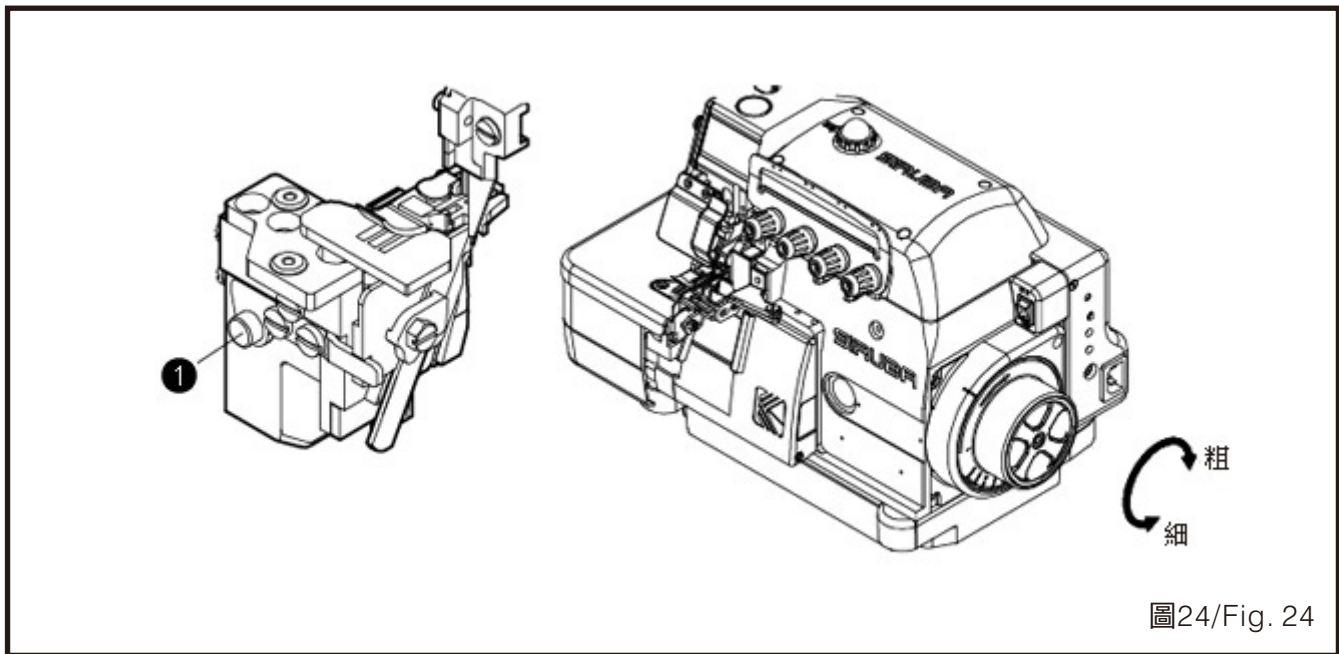
If the stroke of the main feed dog is larger than the stroke of the differential feed dog, the fabric will be extended while sewing.

1.調整方法一：

Otherwise, it will be shrunk

放鬆調整鈕①，當調整桿②向下調整時使布料收縮，反之則伸張，調整後再鎖調整鈕①。(圖25)(表3)

1.Adjust solution 1:

Loosen the adjusting nut ①. Adjust the adjusting rod ② downward will shrink the fabric, whereas move it upward will extend the fabric. Tighten the adjusting nut ① after the adjustment finishes. (Fig.25)(Table3)

Scale		1	2	3	4	5
Differential feed ratio	1:1.3	-	1:0.7	1:0.9	1:1.1	1:1.3
	1:2	1:0.7	1:1	1:1.14	1:1.17	1:2
	1:3	1:1	1:1.5	1:2	1:2.5	1:3
	1:4	1:1.1	1:1.3	1:2.3	1:2.8	1:3.3

表3/Table3



圖25/Fig. 25

2.調整方法二：(圖26)

- (1)鬆開螺絲③，並從機台後方移開外蓋④。
- (2)鬆開螺帽⑤，上下移動連桿⑥。欲增加差動比，把連桿⑥往⊕方向移動。欲減少差動比，把連桿⑥往⊖方向移動。
- (3)在調整過後，把外蓋④放回機台後方並鎖回螺絲③。

2.Adjust solution 2: (Fig.26)

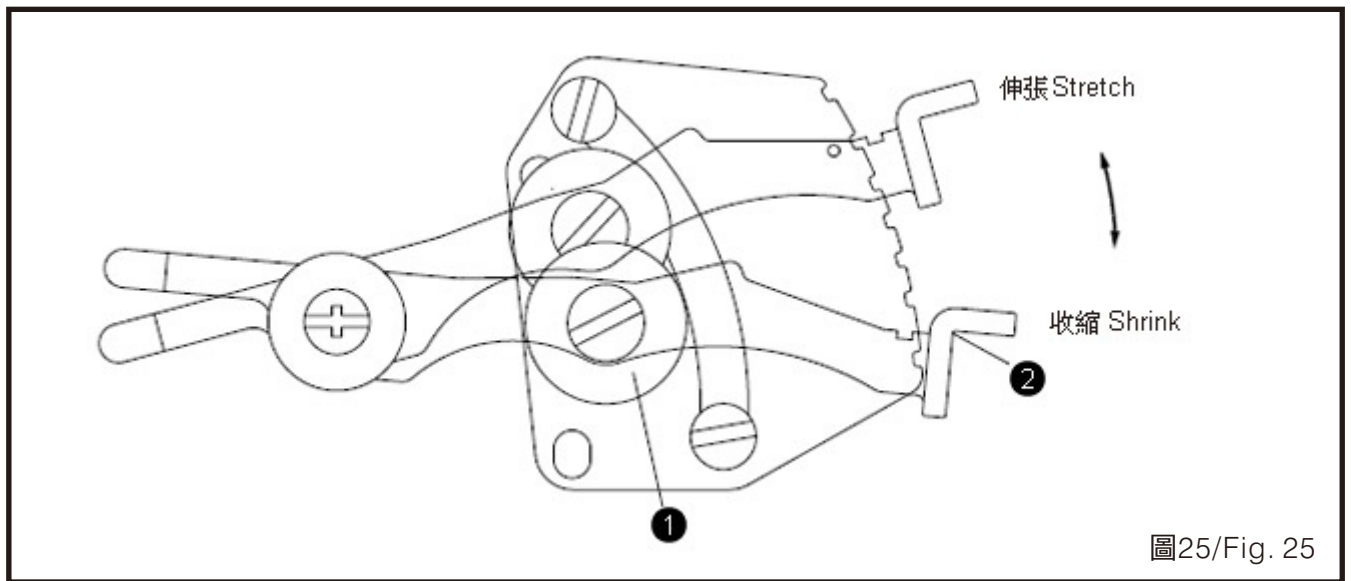
- (1)Loosen the screw ③ and remove the cover ④ from the rear side of the machine bed.
- (2)Loosen the nut ⑤, and move the connecting rod ⑥ upward and downward. To increase the differential feed ratio, move the connecting rod ⑥ to ⊕ direction. To decrease it, move the connecting rod ⑥ to ⊖.
- (3)After adjusting, put the cover ④ back to the rear of the machine bed and tighten the screw ③.



圖26/Fig. 26

## 更換切刀

## REPLACE THE TRIMMERS

### 1.更換上切刀：

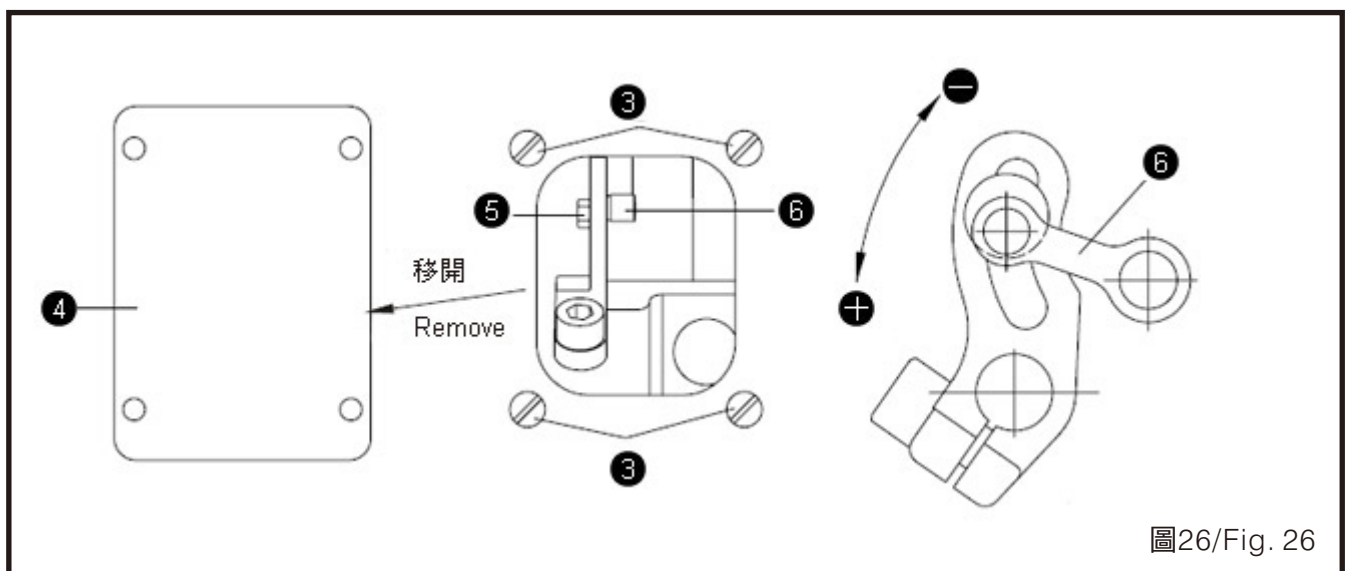
- (1)放鬆螺絲①將下刀座②向左邊推，輕鎖螺絲①。
- (2)取下螺絲③，換上新刀片後，輕輕鎖上螺絲③。
- (3)轉動手輪使上刀移至下死點，調整上刀高低使上刀與下刀相交約 0.5 ~ 1.0 mm，鎖緊螺絲。
- (4)放鬆螺絲①，使下刀座還原位置，並試驗上下刀能剪斷車縫線，鎖緊螺絲①。

### 2.更換下切刀：

- (1)放鬆螺絲①將下刀座②向左邊推，輕鎖螺絲①。
- (2)放鬆螺絲④，取下舊刀換上新刀。
- (3)調整下刀之刀口與針板面平齊後，鎖緊螺絲④。
- (4)放鬆螺絲①，使下刀座還原位置，並試驗上下刀能確實剪斷車縫線，鎖緊螺絲①。(圖27)

### 1. Replace the upper trimmer :

- (1) Loosen the screw ① and move the lower trimmer holder ② to the left. Then, tighten the screw a little.
- (2) Remove the screw ③ and put the new trimmer. Then, tighten the screw a little.
- (3) Turn the pulley to move the upper trimmer to the lower dead point. Adjust the height of the upper trimmer so that the upper trimmer can cross the lower trimmer about 0.5 ~ 1.0 mm. After that, tighten the screw .
- (4) Loosen the screw ① and return the lower trimmer to its original position. Test if the upper and the lower trimmer can cut the thread exactly, and then tighten the screw ① .

### 2. Replace the lower trimmer :

- (1) Loosen the screw ① and move the lower trimmer holder ② to the left. Then, tighten the screw a little.
- (2) Loosen the screw ④ . Take off the trimmer and replace a new one.
- (3) Adjust the edge of the lower trimmer to be alight with the surface of the needle plate. Then, tighten the screw ④ .
- (4) Loosen the screw ① to return the lower trimmer holder to its original position and test if the upper and the lower trimmer can cut the thread exactly. Then, tighten the screw ① .(Fig 27)





圖27/Fig. 27

### 包邊寬度調整

### ADJUST THE HEM WIDTH

1. 轉動皮帶輪，將上刀移至下死點。(圖28)
2. 放鬆螺絲①，向左移動下刀座疊②後，暫時輕鎖螺絲①。
3. 放鬆螺絲③，移動上刀座向左或向右，直到達到所要的包邊寬度後再鎖緊螺絲③。
4. 放鬆螺絲①，使下刀座②位置還原，並測試能切斷車縫線後，鎖緊螺絲①。

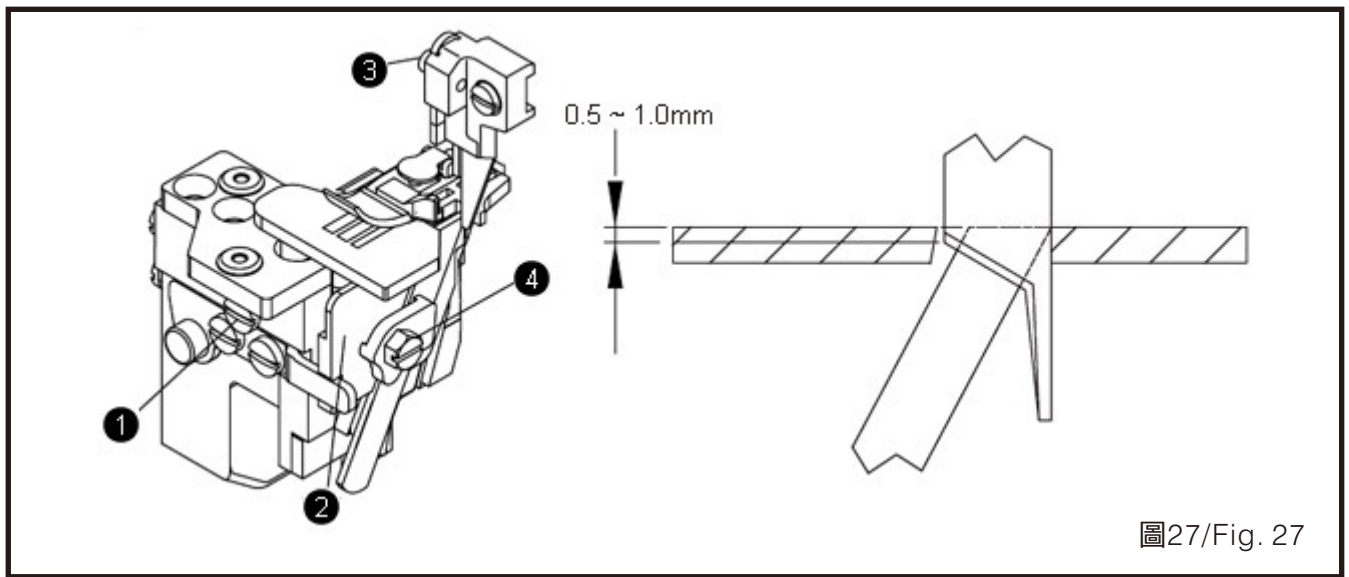
1. Turn the pulley to move the upper trimmer to the lower dead point. (Fig28)
2. Loosen the screw ① and move the lower trimmer holder ② to the left, and then tighten the screw ① a little.
3. Loosen the screw ③ and move the upper trimmer holder ② left or right till reaching the desired width. Then, tighten the screw ③.
4. Loosen the screw ① to return the lower trimmer holder ② to its original position. Test if the trimmers can cut the thread, and then tighten the screw ①.



圖28/Fig. 28

## 針高度之調整

1. 轉動皮帶輪使針上升至最高點時，針尖至針板面之距離為①。(圖29)
2. 調整：
  - (1) 打開上蓋②。
  - (2) 放鬆螺絲③，移動針棒至所需高度鎖緊螺絲回③。
  - (3) 放回上蓋②，並且密合鎖緊。

## ADJUST THE NEEDLE HEIGHT

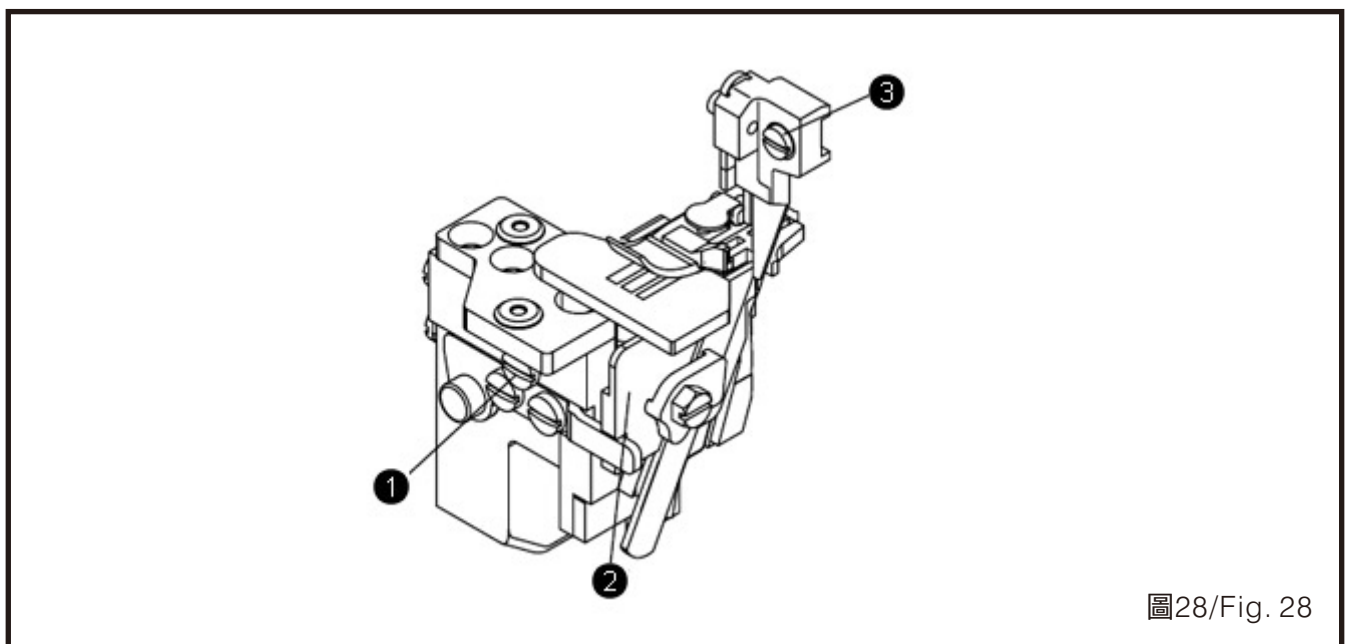
1. The ① is the distance from the needle tip to the surface of the needle plate when the needle is risen to the highest point after turning the pulley. (Fig.29)
2. Adjustments:
  - (1) Open and remove the upper cover ②.
  - (2) Loosen the screw ③, and move the needle bar to the desired height. Then, tighten the screw ③.
  - (3) Put the upper cover ② back, and seal it.

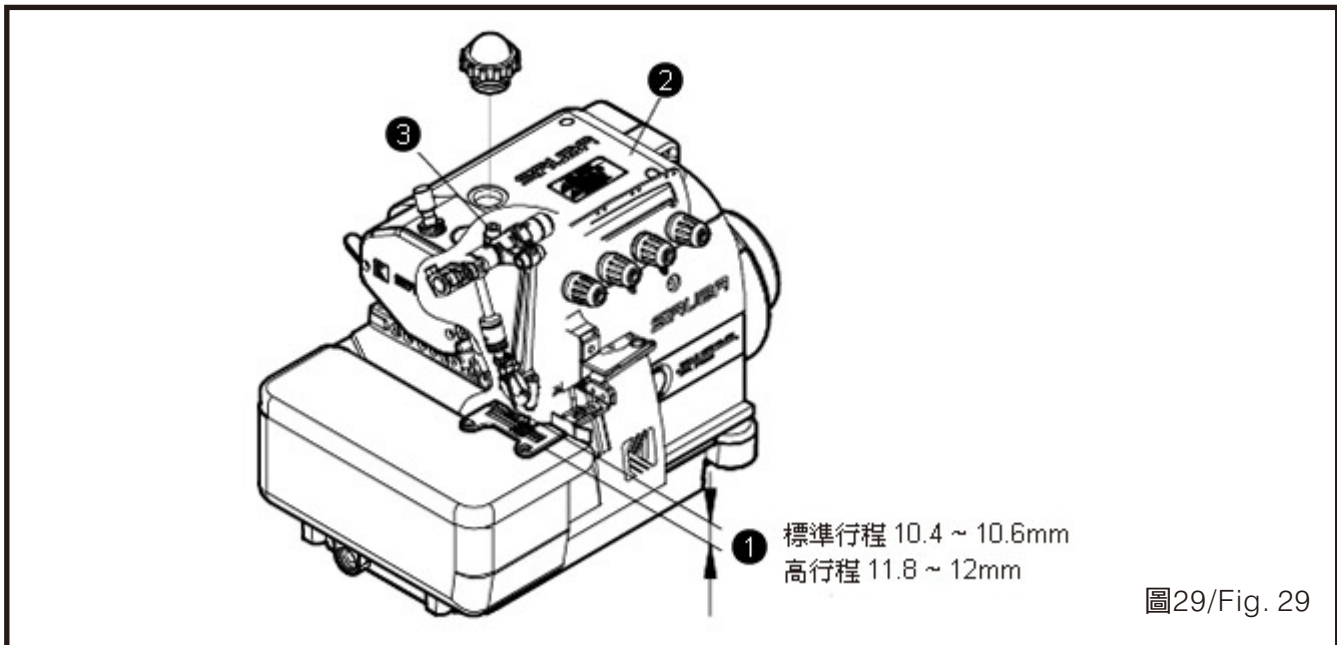

## 押具調整

1. 押具位置調整：(圖30)
  - (1) 放鬆押具彈簧壓力①及押具螺絲⑦。
  - (2) 移動押具⑥，使其押具槽與針板槽一致，使押具底平壓於針板上，鎖緊螺絲⑦。
  - (3) 放鬆螺絲⑤，左右移動④，使③與②疊吻合，且②能上下活動輕順，鎖緊螺絲⑤。

## ADJUST THE PRESSER FOOT

1. Adjust the presser foot position: (Fig.30)
  - (1) Release the pressure spring ① of the presser foot and the screw ⑦ of the presser foot.
  - (2) Move the presser foot ⑥ so that the groove of the presser foot can align with the groove of the needle plate. Also, the bottom of the presser foot can stand on the needle plate flatly, and then tighten the screw.
  - (3) Loosen the screw ⑤, and move ④ left and right so that ③ can match ② and ② can move upward and downward smoothly. Then, tighten the screw ⑤.

(4)調整適當壓力，螺絲①順時針方向旋轉時，壓力加大，反之減弱。

(4)To adjust to a proper pressure: turn the screw ① clockwise will increase the pressure, whereas turn it counter clockwise will decrease the pressure.



圖30/Fig. 30

## 2. 押具提升量調整

- (1)轉動皮帶輪使送具降至針板下，押具底平貼針板。
- (2)放鬆螺帽⑪，壓下拉桿⑬使押具上升至適當位置約 5.0 ~ 5.5mm，調整螺絲⑫ 及定螺帽⑪。
- (3)拉桿⑧ 與固定座⑨ 須保持有1mm 的間隙，可輕輕放鬆螺絲⑩ 調整。
- (4)要確實鎖緊螺絲⑩。(圖31)

## 2. Adjust the lift amount of the pressure foot.

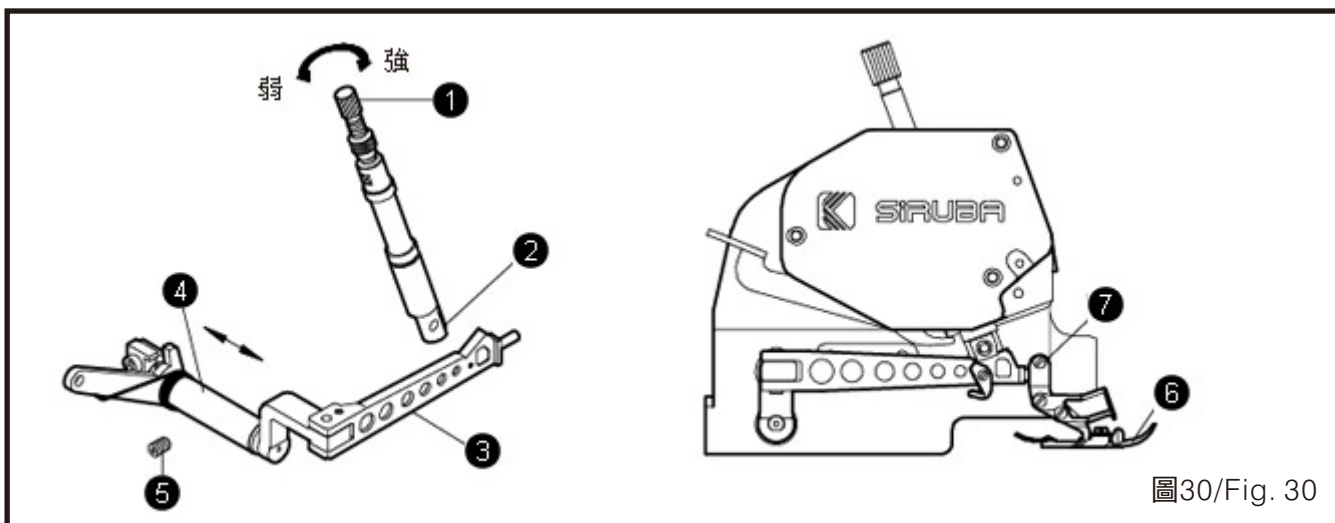
- (1)Rotate the pulley to move the feed dog downward until the feed dog is under the needle plate, as well as the bottom of the presser foot touches the needle plate flatly.
- (2)Loosen the nut ⑪, and press the pull rod ⑬ in order to rise the presser foot from the needle plate in about 5.0 ~ 5.5 mm. Then, adjust the screw ⑫ and tighten the nut ⑪.
- (3)There should be a clearance of 1 mm between the pull rod ⑧ and the fixed bracket ⑨, which can be adjusted by loosening the screw ⑩ slightly.
- (4)After all the adjustments above please tighten the screw ⑩. (Fig.31)



圖31/Fig. 31

## 1. 送具高度調整 (圖32)

- (1) 轉動皮帶輪使送具上升至針板上最高點。
- (2) 放鬆螺絲①，上下移動主送具②，使其齒面高出針板面約0.7 ~ 0.9mm，鎖緊螺絲①。
- (3) 放鬆螺絲③，上下移動差動送具④使其齒面高出針板面約0.7 ~ 0.9mm 鎖緊螺絲③。

## 1. Adjust the feed dog height (Fig 32)

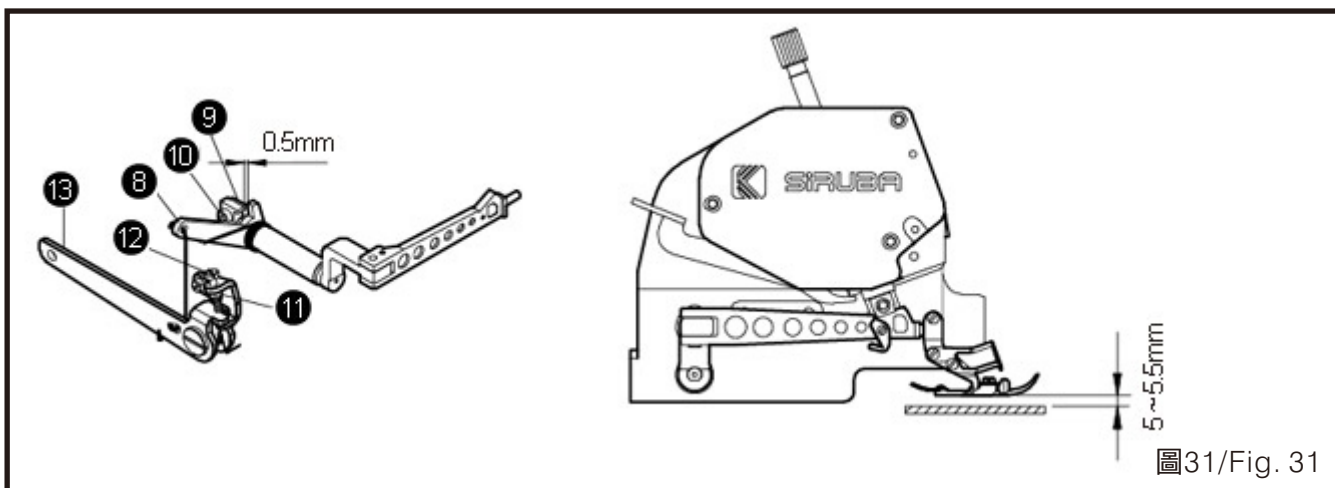
- (1) Rotate the pulley to rise the feed dog to the highest point of the needle plate.
- (2) Loosen the screw ①, and move the main feed dog ② up and down in order to keep the teeth side over the needle plate about 0.7 ~ 0.9mm. Then tighten the screw ①.
- (3) Loosen the screw ③, and move the differential feed dog ④ up and down in order to keep the teeth side over the needle plate about 0.7 ~ 0.9mm. Then, tighten the screw ③.



圖32/ Fig. 32

## 2. 送具水平調整 (圖33)

- (1) 送具齒的齒面在運轉的循環中，必須保持針板面呈水平。
- (2) 調整時放鬆螺絲⑤，旋轉後支軸⑥齒面呈水平後固定螺絲⑤。

## 2. Adjust the feed dog horizontally (Fig 33)

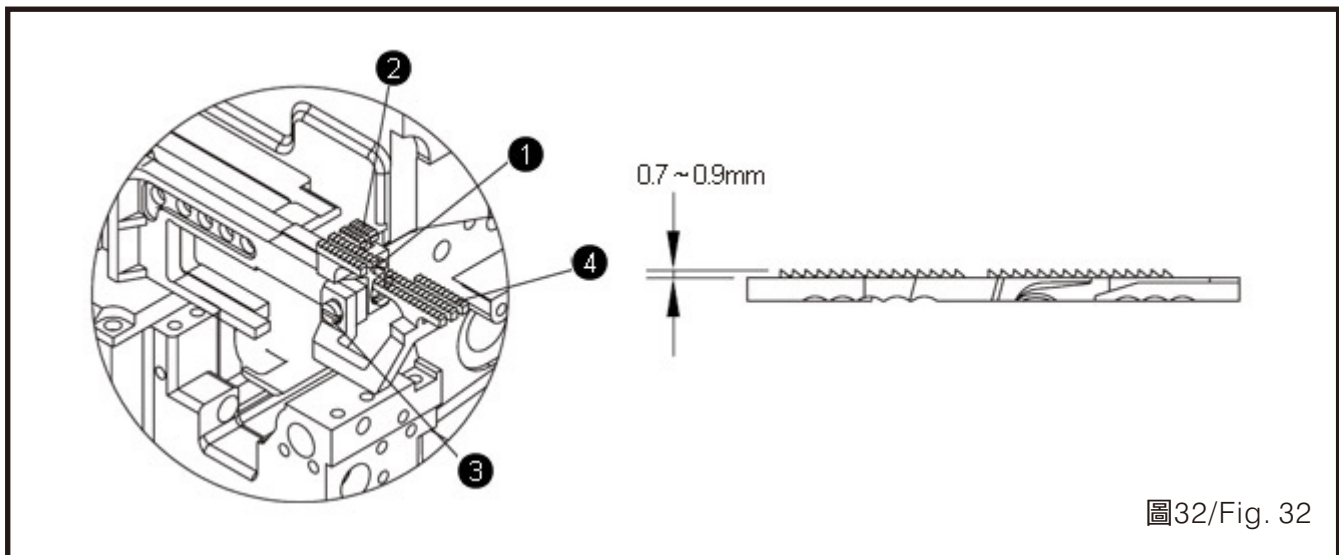
- (1) During operation, the teeth side of the feed dog should keep parallel with the surface of the needle plate.
- (2) For adjustment, loosen the screw ⑤, and rotate the rear support shaft ⑥. Do not tighten the screw ⑤ until the teeth side of the feed dog is horizontal.



圖33/Fig. 33

3. 輔助送布齒高度

輔助送具⑦，其齒面比送布齒齒面低0.3 ~ 0.5mm，可放鬆螺絲⑧來調整。(圖34)

3. Adjust the auxiliary feed dog height.

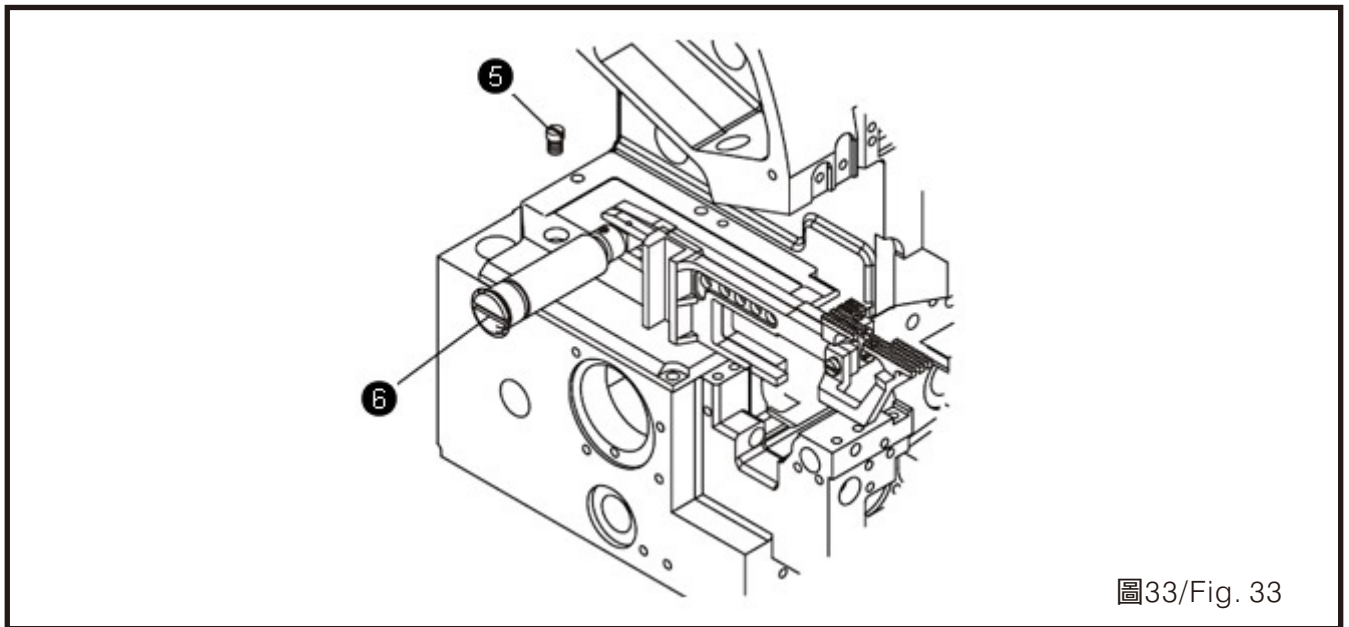
The teeth side of the auxiliary feed dog is 0.3 ~ 0.5mm lower than the teed dog. The height can be adjusted by loosening the screw⑧.(Fig.34)



圖34/Fig. 34

針與勾針之關係

THE RELATIONSHIP BETWEEN NEEDLE AND LOOPER

1. 針與上勾針之關係

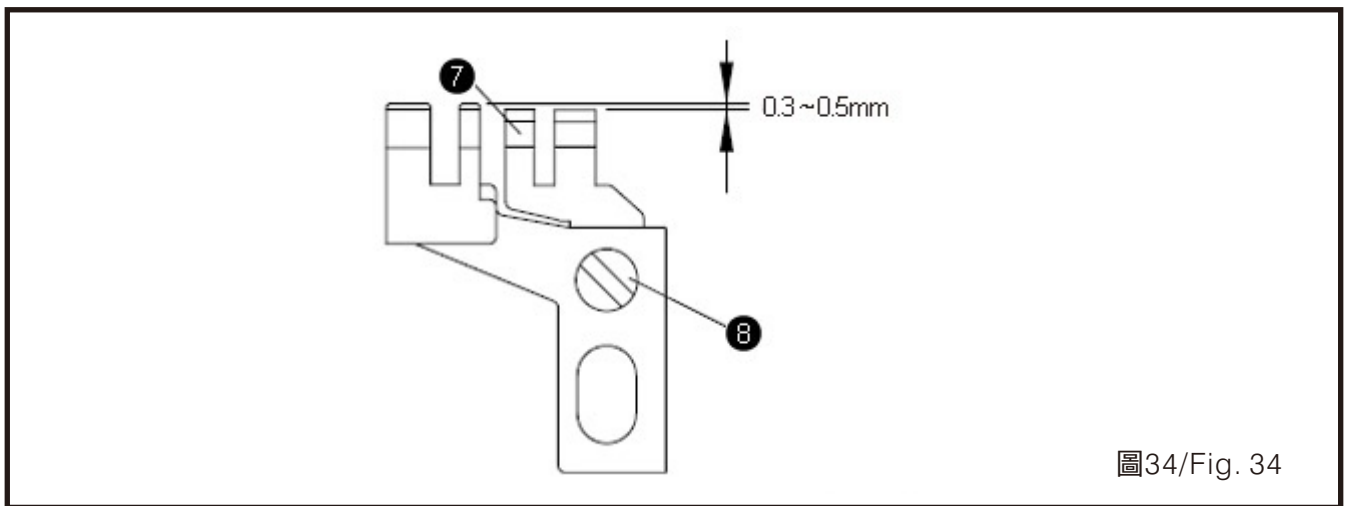
當上勾針移至最左時，勾針尖端與針中心距約4.4 ~ 4.7mm，雙針時其左針中心與勾針尖端距約5.4 ~ 5.7mm。(圖35)

1. The relationship between the needle and the upper looper

When the upper looper moves to the leftest point, the distance from the looper tip to the middle line of the needle is 4.4 ~ 4.7mm. For double needles model, the distance from the looper tip to the middle line of the left needle is 5.4 ~ 5.7mm.(Fig.35)

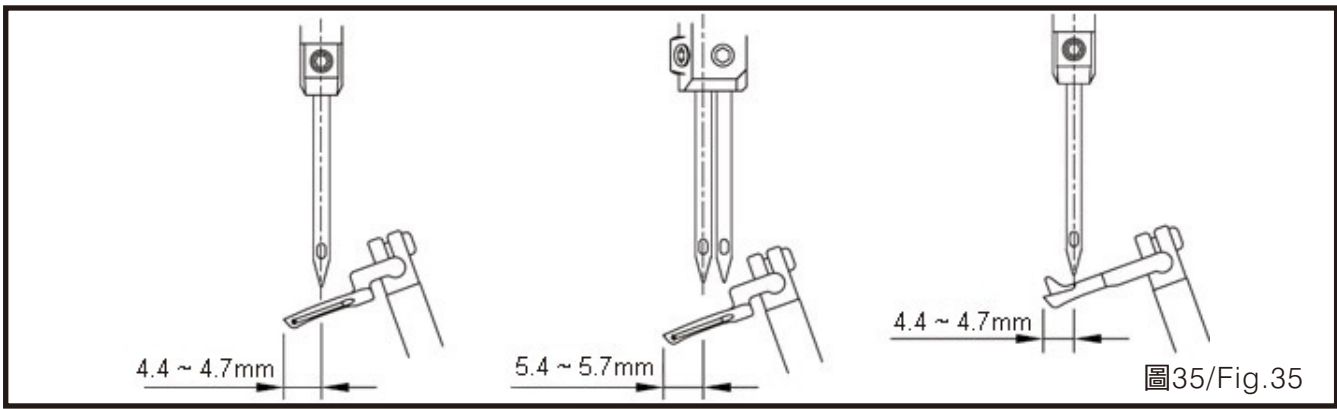

2. 針與下勾針之關係

(1) 當下勾針移至最左時，勾針尖端與針中心距約3.7 ~ 3.9mm (雙針時以左針為主)。 (圖36)

2. The relationship between the needle and the lower looper.

(1) When the lower looper moves to the leftmost point, the distance between the looper tip and the middle line of the needle should be about 3.7 ~ 3.9mm. For double needles model, the distance is from the lower looper tip to the middle line of the left needle. (Fig.36)

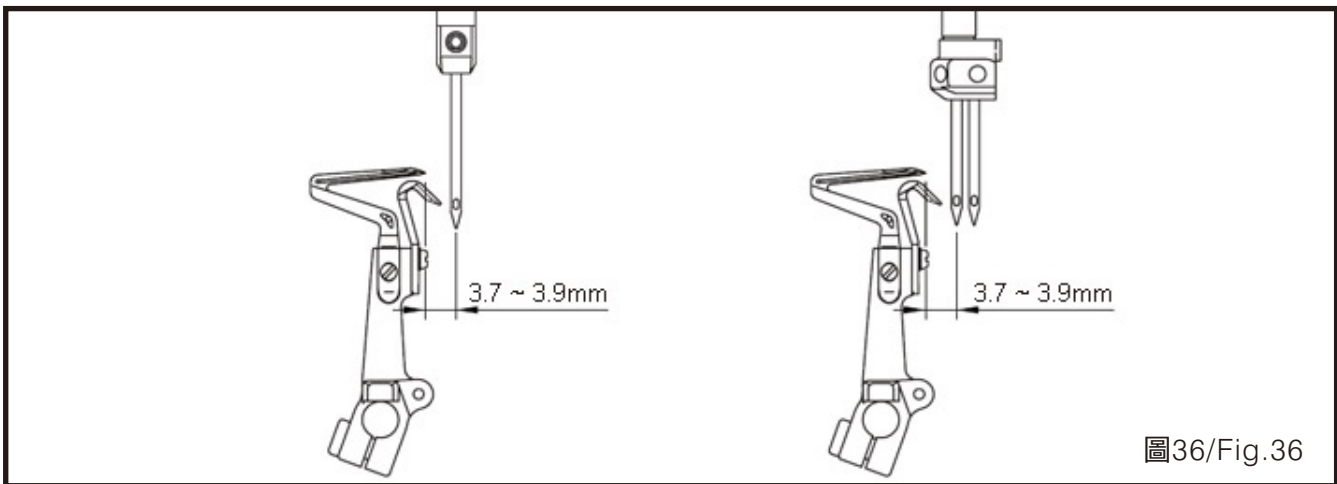

(2) 當下勾針向右移至針中心時 (雙針時以左針為主)，針與勾針之間隙為0 ~ 0.05 mm。 (圖37)

(2) When the lower looper moves right to the middle line of the needle (use the left needle as standard when it's double needle model), the clearance between them should be 0 ~ 0.5mm. (Fig.37)

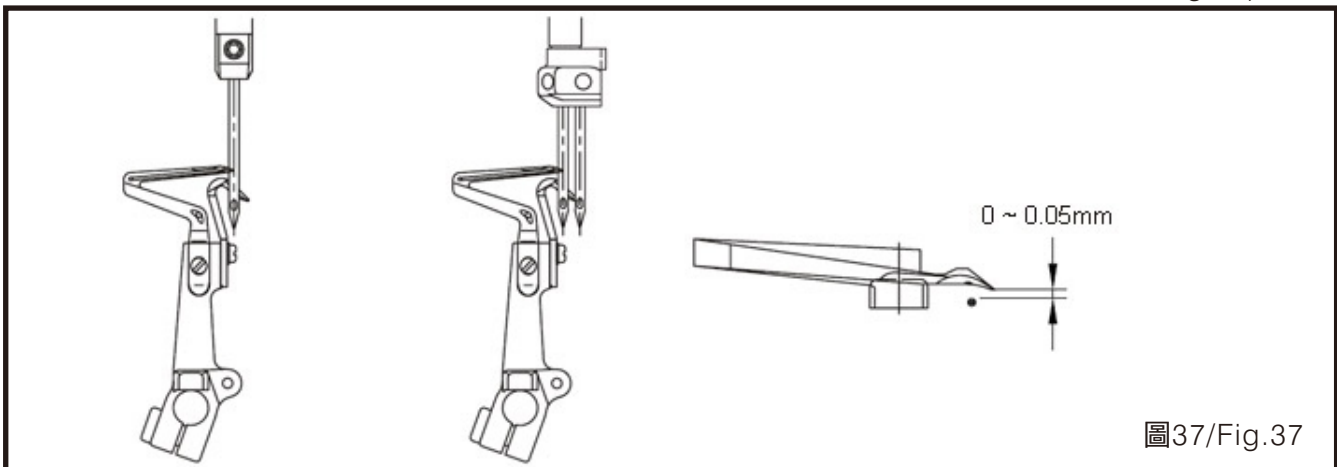

### 3.上勾針與下勾針之關係

當上下勾針相交時，兩勾針盡量接近，但不可摩擦或碰撞。其間隙②點為0.5 mm,①點為0.2mm。(圖38)

3.The relationship between the upper looper and the lower looper.

When the upper and the lower looper cross, keep them as close as possible. Somehow, the loopers shall not either touch or collide to each other. The clearance point is 0.5 mm, as well as the clearance point is 0.2 mm. (Fig.38)

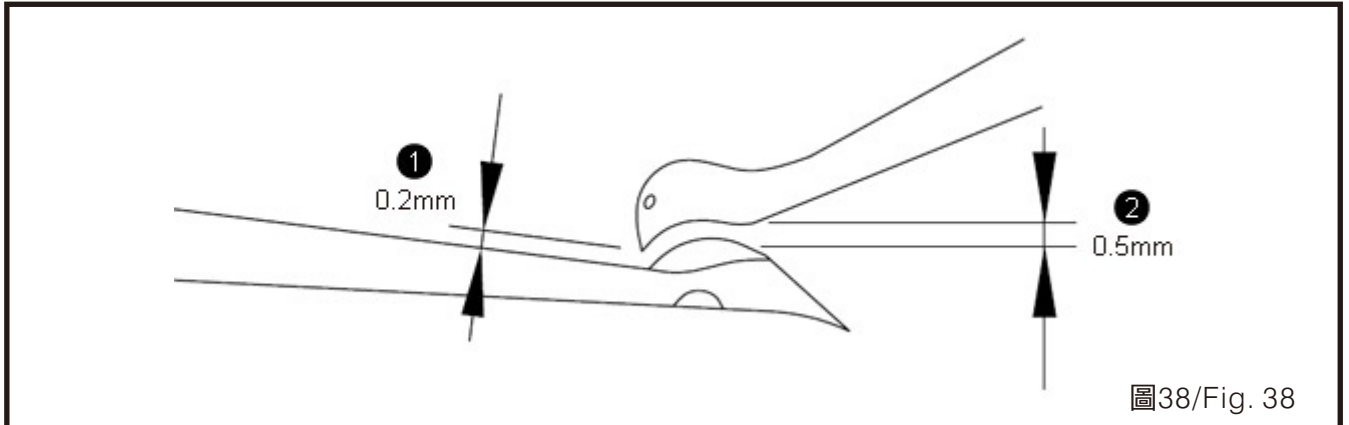

### 4.針與環縫勾針之關係

當環縫勾針移至最左時，勾針尖端與針之中心距離為1.4 ~ 1.6mm。(圖39)

4.The relationship between the needle and the chainstitch looper.

When the chainstitch looper moves to the leftest point, the distance from the chainstitch looper pin to the middle line of the needle is 1.4 ~ 1.6mm. (Fig.39)

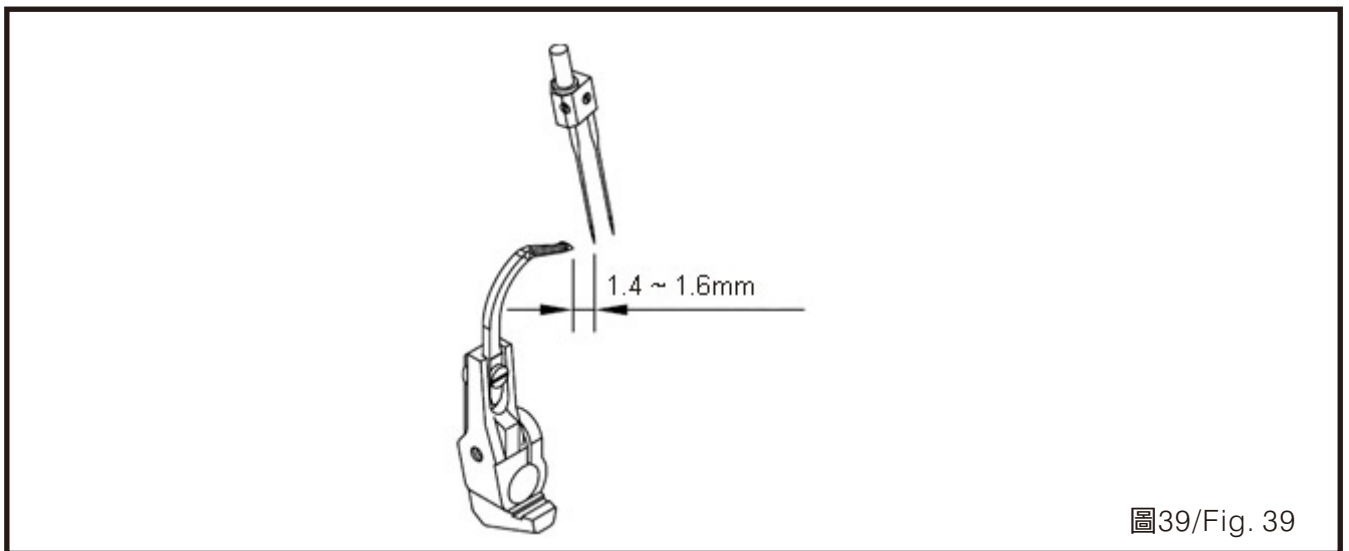

### 5.針與擋針片之關係

(1)當下勾針由左向右至針中心時（雙針時以左針為主），針與後檔針片之間隙為0 ~ 0.05mm。

5.The relationship between the needle and the needle guard

(1)When the lower looper moves from left to right to the central line of the needle (when it's double needle model, it means the left needle), the clearance from the needle to the rear needle guard is 0 ~ 0.05 mm.

(2)當針在下死點時，針與前擋針片之間  
隙為0.1 ~ 0.2mm(圖40)

(2) When the needle is at the lower dead  
point, the clearance between the needle  
and the front needle guard is 0.1 ~  
0.2mm. (Fig.40)

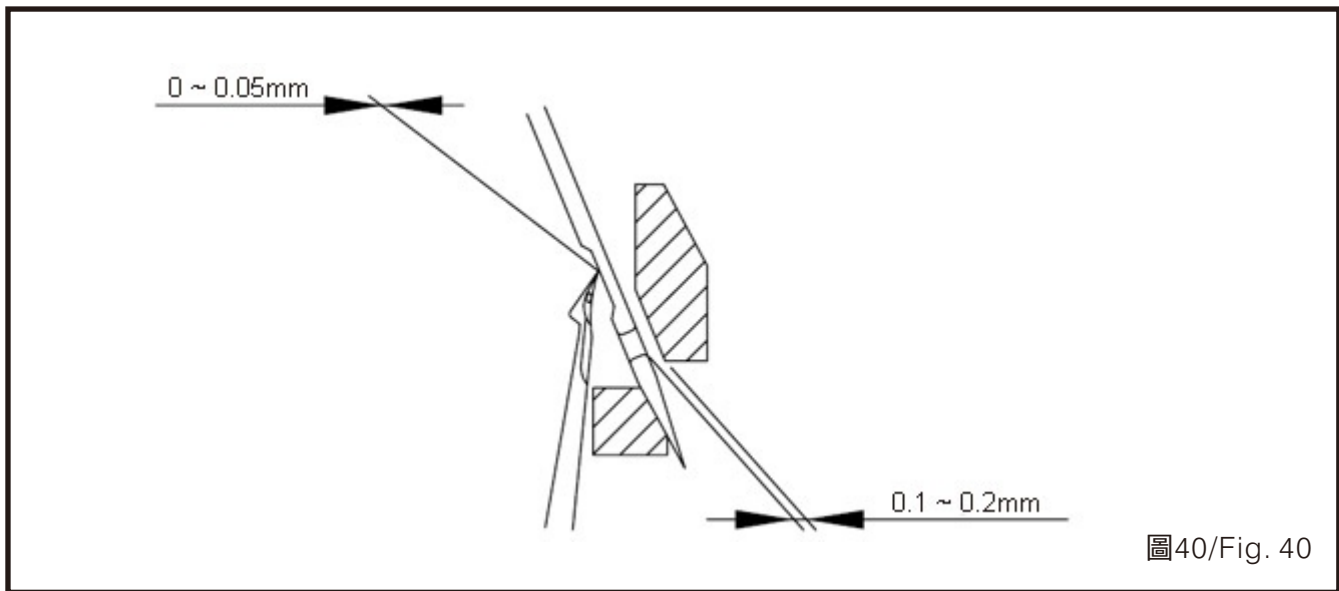

## 環勾針運動量之調整

## ADJUST THE CHAINSTITCH LOOPER MOVEMENT AMOUNT

環勾針之運動呈橢圓形，當針號數變動過  
大時或有必要調整環勾針之前後運轉量④  
時，請依照以下步驟調整。

- 1.打開縫紉機背面的封蓋①。
- 2.輕輕放鬆螺絲③。
- 3.旋轉調整螺絲②，向⊕方向轉動加大前  
後運動量，向⊖方向轉動減少前後運動  
量。
- 4.調整後鎖緊螺絲③。
- 5.鎖緊封蓋①。(圖41)

The movement of the chainstitch looper is  
oblong shape. When the difference of the  
changed needle number is too large, or there  
is necessary to adjust the front/rear  
movement amount ④ a of the chainstitch  
looper, please follow the steps below to  
adjust.

1. Open the sealed cover ① in the back side of  
the machine.
2. Loosen the screw ③ slightly.
3. Turn the screw ② to adjust. To increase the  
movement amount, turn to ⊕ direction. To  
decrease the movement amount, turn to ⊖  
direction.
4. Tighten the screw ③ after the adjustment.
5. Then, seal the cover ①. (Fig.41)





圖41/Fig. 41

## 濾網清潔

1. 將螺絲放鬆旋開，取出濾網清理乾淨後，再鎖緊。
2. 為延長本機器之壽命，請在每使用一段時間後卸下，清潔乾淨。(圖42)

## FILTER CLEANING

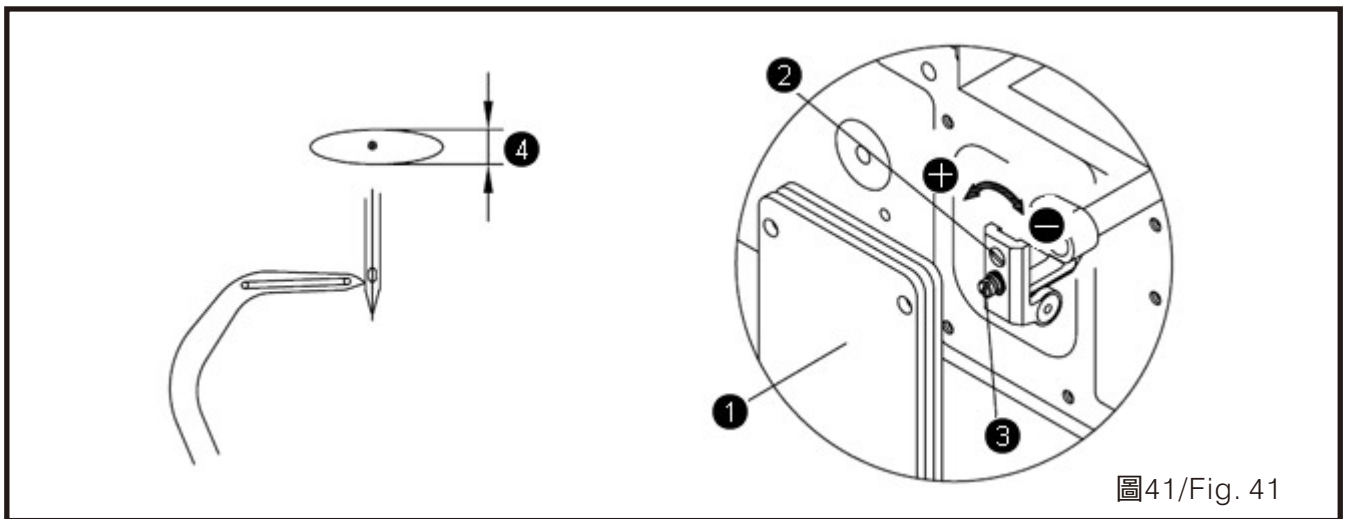
1. Loosen the screw and take out the filter for cleaning
2. To extend the machine life, please clean the filter frequently. (Fig.42)



圖42/Fig.42

## 電眼感測器調整

1. 調整電眼感測器與工作平台呈平行方向，再鎖緊固定螺絲④。
2. 打開縫紉機電源，此時電眼感測器之電源指示燈③呈綠燈，且為恆亮狀態，若此時檢測燈之橘燈②，呈現滅的狀態，則以一字起子⑤，調整感測強度旋鈕①，直到檢測燈之橘燈②亮起。(圖43)

## ADJUST THE ELECTRIC EYE SENSOR

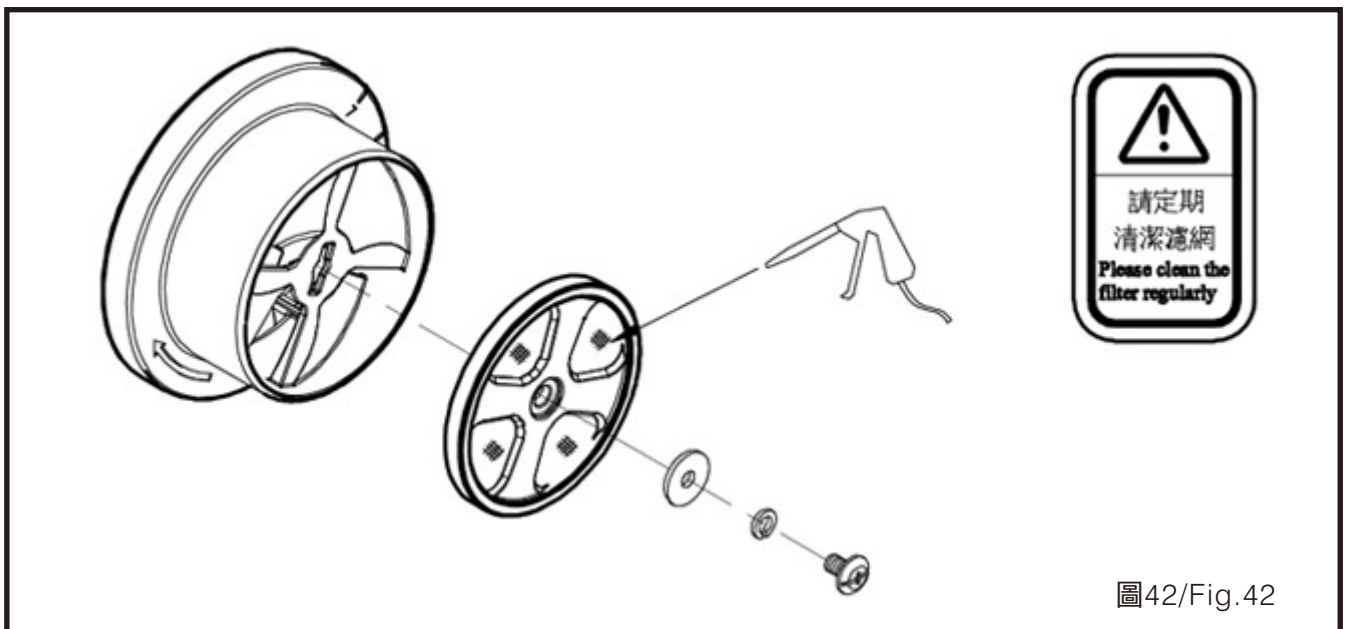
1. Parallelize the electric eye sensor with the work table and fasted the screw ④.
2. Turn on the power and then the power light of the sensor ③ is green and eternal. If the orange light ② is extinguished, adjust the knob ① of the intensity sensor with a slotted screwdriver ⑤ until the orange light ② is lit. (Fig.43)

3. 以待縫製物測試，放入縫製物時，檢測燈②為滅的狀態，表示目前已檢測到縫製物；移除縫製物時，檢測燈②之橘燈會亮起。
4. 若電眼感測器靈敏度有些許誤差，可調整感測強度旋鈕①至最佳位置。
5. 以此方式反覆測試電眼感測器數次，若皆呈正常動作，即表示已調整完成，此時即可開始進行車縫作業。
6. 電眼感測器為光電反射原理，若遇下列布料(註1)可能會造成誤判，建議將此電眼感測器功能關閉。(圖43)

註1：易造成誤判之布料：

※網紗布料

※表面有反光貼片的布料

註2：出廠時皆已調校，僅須針對感測強度調整即可。

3. For testing the sewing, the indicated light ② would be extinguished after putting the sewing. It demonstrates the sewing is detected. The orange light ② is lit when removing the sewing.
4. If there is some deviation in the sensor's sensitivity, adjust the knob ① of the intensity to the optimal position.
5. Test the sensor with the manner for several times. If it works regularly, it indicates the adjustment is completed and can start sewing.
6. The sensor follows the electro-optical reflection. Thus, if sewing the following clothing, it may cause the deviation, and it is suggested to turn off the sensor function. (Fig43)

Remark1: The clothing easy to cause the deviation:

※Sewing made of gauze.

※The fabric with the surface of reflective patch.

Remark2: The adjustment is accomplished before leaving the factory. It is enough to adjust the sensor's sensitivity.



圖43/ Fig. 43

## 電眼自動感應切線系統

紅色按鈕為電眼感應切線系統，按鈕按下即可呈現自動切線裝置，若欲取消電眼感應切線系統，再次按下按鈕即可。  
(圖44)

## ELECTRIC EYE AUTOMATIC SENSOR

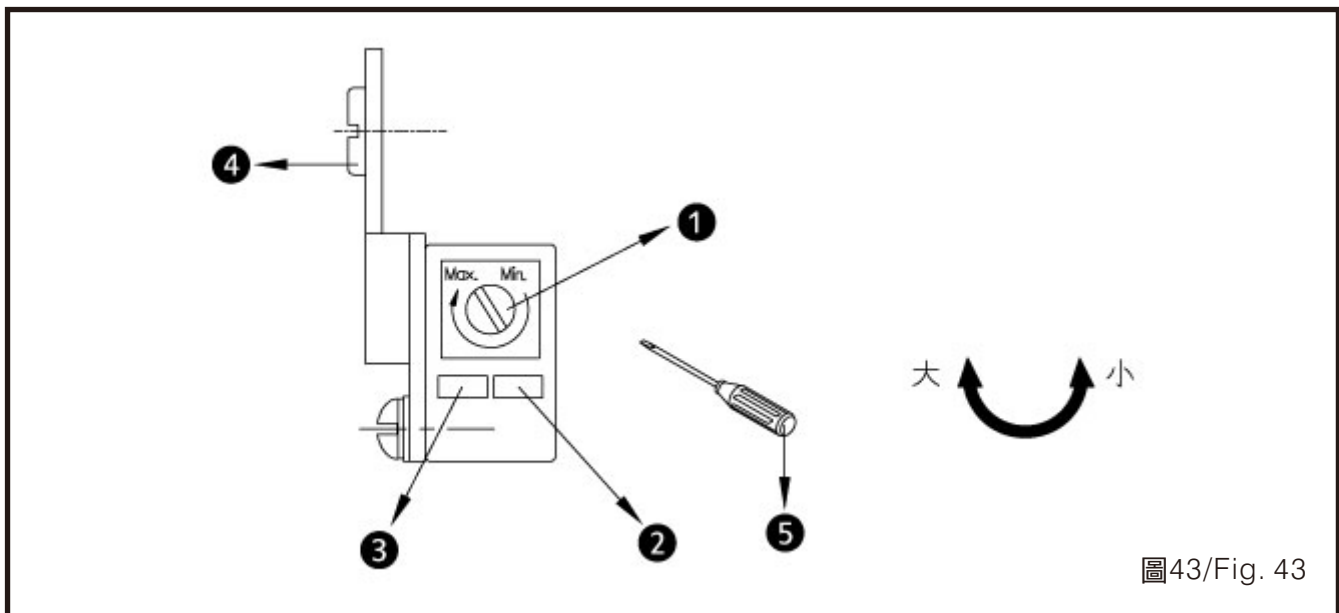
The red button is for the trimming system of the electric eye sensor. It can perform the auto trimming device by pressing the button. If you want to cancel this trimming system, just press the button again.(Fig.44)

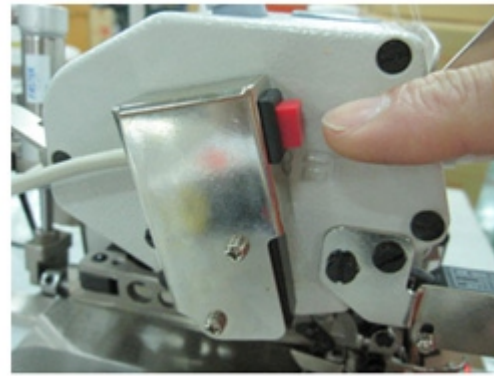
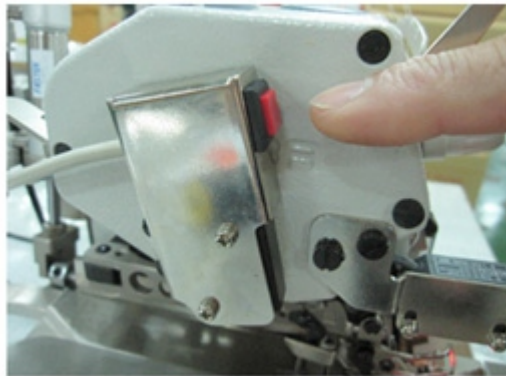

ON : 開啓自動切線系統  
ON : Turn on the auto trimming system

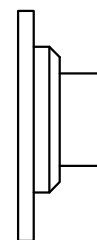

OFF : 關閉自動切線系統  
OFF : Turn off the auto trimming system

圖44/Fig. 44

## 控制箱規格說明

1. 電機類型：交流伺服電機
2. 輸入電壓：AC 200V-240V
3. 輸入頻率：50Hz-60Hz
4. 電機輸出功率：350W
5. 電機輸出扭力：0.577N-m at 6000rpm
6. 電機最大輸出轉速：6000rpm
7. 電機最小輸出轉速：200rpm
8. 電機轉速爬升與下降時間：小於200ms
9. 照明燈規格：DC12V/40mA
10. 電磁閥規格：24V
11. 電磁鐵規格：24V (圖45)

## CONTROL BOX SPECIFICATION

1. Motor : Alternating Current Servo Motor
2. Input Voltage : AC 200V-240V
3. Input Frequency : 50Hz-60Hz
4. Output Power : 350W
5. Output Torsion : 0.577N-m at 6000rpm
6. Maximum RPM : 6000rpm
7. Minimum RPM : 200rpm
8. RPM Speed Time : Less Than 200ms
9. Illumination : DC12V/40mA
10. Electromagnet Valve : 24V
11. Electromagnet Solenoid : 24V (Fig45)



圖45/Fig. 45

## 控制箱調整

## CONTROL BOX SETTING

### 1. 電機轉速操作設定(圖46)

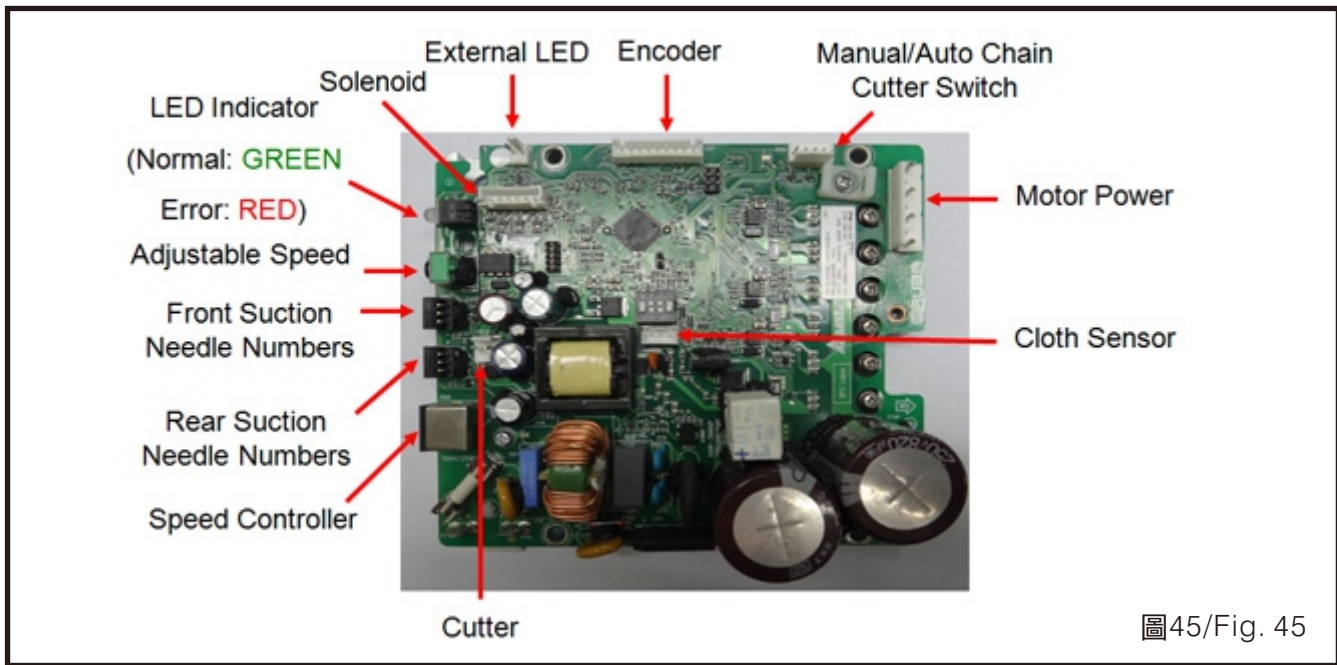
本公司出廠設定為5000rpm，調速旋鈕逆時針旋轉至底為最低轉速200rpm，順時針轉到最底為5000rpm。如需修正電機最大轉速時，需先行打開外殼並針對撥碼開關做設定，再調整調速旋鈕，以達電機轉速調整之動作。例如當撥碼開關設定4000rpm時，調速旋鈕逆時針旋轉至底為最低轉速200rpm，順時針轉到最底為4000rpm。

#### (1) 撥碼開關設定(SW1)

### 1. Motor speed settings (Fig.46)

The factory default setting is at 5000rpm, and the minimum speed is at 200rpm when speed control knob is turning counterclockwise to the end, and at 5000rpm when turning clockwise to the bottom. To amend the maximum motor speed, you need to open the case first to set the DIP switch settings, and then adjust the speed control knob. For example, when the DIP switch settings is 4000rpm, the minimum speed is at 200 rpm when turning the speed control knob counterclockwise to the end, and at 4000rpm when turning clockwise to the bottom.

#### (1) DIP switch settings



圖46/Fig. 46

自動切線模式 Auto thread cutting mode				
DIP 1 速度切換 Speed Switch	DIP 2 速度切換 Speed Switch	DIP 3 上下停針 Upper/Lower needle positioning	DIP 4 自動/VT Auto/VT	備註 Remarks
OFF	OFF	X	ON	0 ~ 3000rpm
OFF	ON	X	ON	0 ~ 4000rpm
ON	OFF	X	ON	0 ~ 5000rpm
ON	ON	X	ON	0 ~ 6000rpm

表4/Table4

CT/VT模式 CT/VT mode				
DIP 1 速度切換 Speed Switch	DIP 2 速度切換 Speed Switch	DIP 3 上下停針 Upper/Lower needle positioning	DIP 4 自動/VT Auto/VT	備註 Remarks
OFF	OFF	X	OFF	0 ~ 3000rpm
OFF	ON	X	OFF	0 ~ 4000rpm
ON	OFF	X	OFF	0 ~ 5000rpm
ON	ON	X	OFF	0 ~ 6000rpm

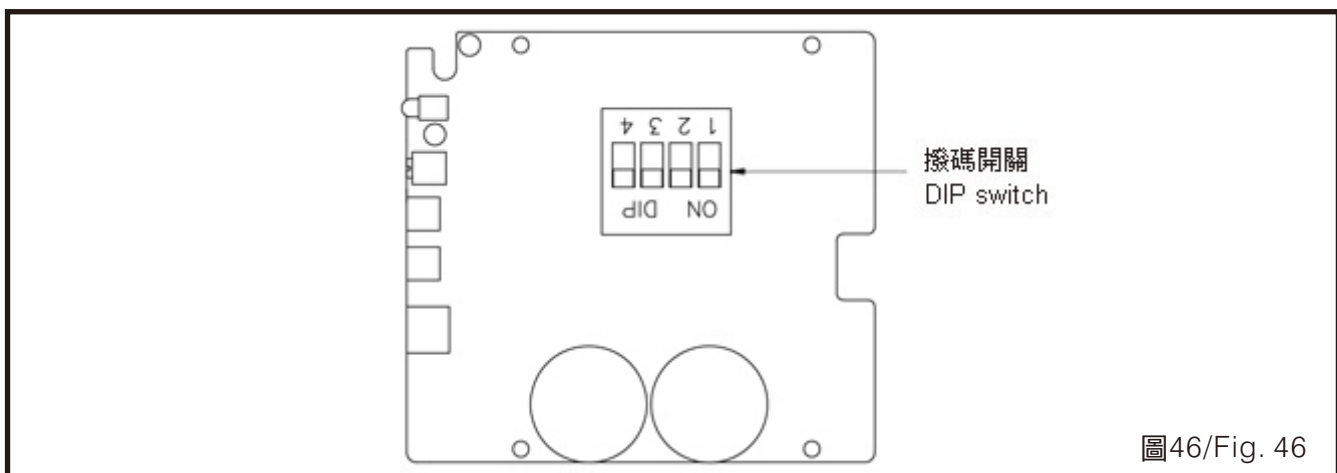
表5/Table5

上/下停針設定模式 Upper / Lower needle positioning mode				
DIP 1 速度切換 Speed Switch	DIP 2 速度切換 Speed Switch	DIP 3 上下停針 Upper/Lower needle positioning	DIP 4 自動/VT Auto/VT	備註 Remarks
X	X	OFF	X	上停針 Upper needle positioning
X	X	ON	X	下停針 Lower needle positioning

表6/Table6

註：切換開關”4”定義：ON：為全功能模式，OFF：為VT、CT模式。

Remark: The definition of the switch “4”: ON: The Full-function mode; OFF: The VT, CT mode.

(2)控制箱調整(圖47)

- ①為LED燈，綠色燈表示控制器正常運作，紅燈表示控制器異常，若閃燈其原因請詳閱故障檢修。
- ②為速度調整旋鈕，可用一字起子調整，順時針調整縫速加快，反之變慢。
- ③為前吸風針數調整旋鈕
- ④為後吸風針數調整旋鈕
- ⑤為控速器插座

(2)Control Box Adjustment (Fig.47)

- ①LED: Green color stands for the controller being working well and red color stands for the controller being abnormal. Please refer to the troubleshooting section if you see LED is blinking.
- ②Speed adjustment switch: Use a slotted screwdriver to adjust . Clockwise adjustment would increase the sewing speed. If adjust counter clockwise direction would decrease the sewing speed.
- ③Front air suction adjustment switch
- ④Rear air suction adjustment switch
- ⑤Speed controller socket



圖47/Fig. 47

2.前後吸風針數/速度VR說明

(1)自動切線模式(DIP 4 SETUP ON)

a.前吸風針數調整旋鈕：(表7)

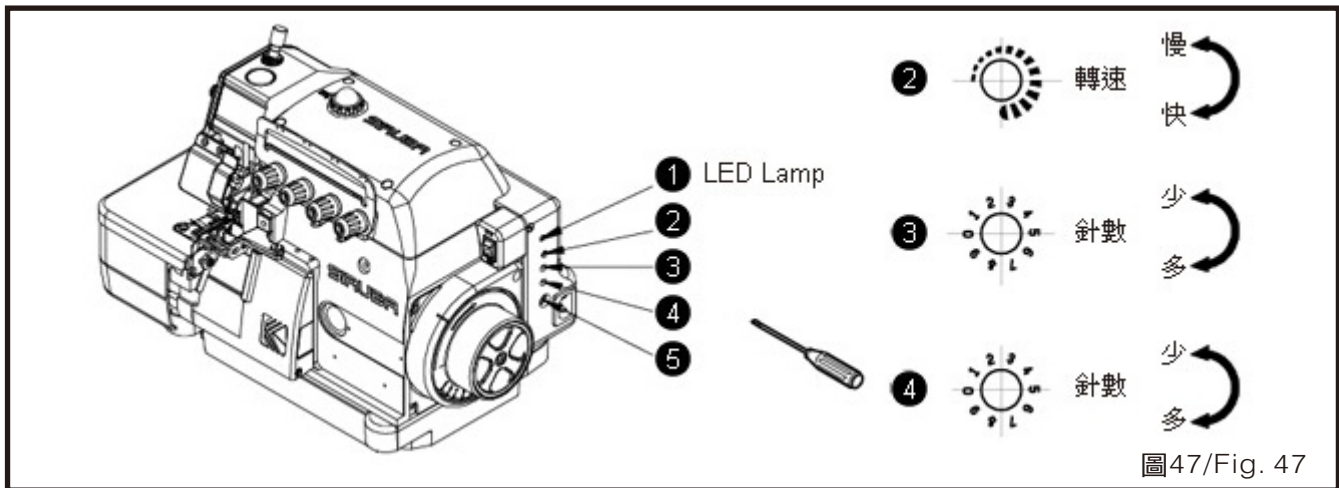
2.Front & Rear suction needle numbers / Speed VR features.

(1)Auto chain cutter(DIP 4 SETUP ON):

a.Front suction needle numbers(SW2)  
(Table7)

刻度Scale	0	1	2	3	4	5	6	7	8	9
針數Needle	0	2	4	6	8	10	12	14	16	18

(刻度 0 為不吸風切線)

(0 means no suction & cutter function )

表7/Table7

b.後吸風針數調整旋鈕：(表8)

b.Rear suction needle numbers(SW3)  
:(Table8)

刻度Scale	0	1	2	3	4	5	6	7	8	9
針數Needle	0	4	8	12	16	20	24	28	32	36

(刻度 0 為不吸風切線)

(0 means no suction & cutter function )

表8/Table8

(2)CT/VT模式(DIP 4 SETUP OFF)

a.前吸風針數調整旋鈕：(表9)

刻度Scale	0	1	2	3	4	5	6	7	8	9
針數Needle	0	4	8	12	16	20	24	28	32	36

(刻度 0 為不吸風切線)

(0 means no suction & cutter function )

表9/Table9

b.後吸風針數調整旋鈕：(表10)

刻度Scale	0	1	2	3	4	5	6	7	8	9
針數Needle	0	8	16	24	32	40	48	56	64	72

(刻度 0 為不吸風切線)

(0 means no suction & cutter function )

表10/Table10

\*VR703 逆時針旋轉至底為最低轉速  
200rpm

\*The lowest speed of VR703 is 200rpm  
when turned counter clockwise to the  
end

\*VR703 順時針旋轉至底為最高轉速  
(視DIP SW1,2而定)

\*VR703 highest speed is when turned  
clockwise to the end (depending on  
DIP SW1,2)

3. 控制箱規格說明

(1)產品主要動作與保護功能說明

本產品為工業縫紉機數控交流伺服電機驅動系統，藉由數位化控制，使縫紉機具急升、急降、精準定位，並配有抬壓腳，自動切線頭，線頭集塵系統等功能，方便使用者作業。四位元撥碼開關可設定電機最大轉速運轉於6000rpm、5000rpm、4000rpm、3000rpm，此外尚可藉由調速旋鈕微調電機最大轉速設定(例如：四位元撥碼開關設定為四千轉，藉由調速旋鈕可使縫紉機操作於200rpm至4000rpm)，詳細設定請參閱電機轉速操作設定。

3. Product Illustration

(1)Product main function and protecting function

This product is operated with digital AC servo motor driving system, controlled digitally to facilitate user operation, along with the function of lifting and lowering the sewing machines, precise positioning function, and equipped with presser foot lifter, auto thread trimmer, and lint and dust collection system. The 4 digit DIP switch can set the maximum motor speed operation at 6000rpm, 5000rpm, 4000rpm, 3000rpm, and the maximum motor speed can be set by fine tuning the speed control knob (for example: The 4 digit DIP switch is set to 4000rpm, and you can set the speed from 200rpm to 4000rpm with the speed control knob). For detailed settings please refer to the motor speed settings.

另外，本產品提供DC12V/40mA、三組DC24V/80mA、DC24V/4.2A電源供縫紉機照明燈、電磁閥及電磁鐵使用。最後為確保使用者安全，本產品保護功能如下：高&低電壓報警、驅動模組過溫報警、電機編碼器異常報警、過電流報警、電機或機台堵轉報警、+24V低電壓異常報警。

(2)系統規格：

- 電機類型：交流伺服電機
- 輸入電壓：AC 200V-240V
- 輸入頻率：50Hz-60Hz
- 電機輸出功率：350W
- 電機輸出扭力：0.577N-m at 6000rpm
- 電機最大輸出轉速：6000rpm
- 電機最小輸出轉速：200rpm
- 電機轉速爬升與下降時間：小於2000ms
- 照明燈規格：DC12V/40mA
- 電磁閥規格：24V/80mA
- 電磁鐵規格：24V/4.2A within 100ms

(3)注意事項：

- a. 進行以下行為時，必須將系統電源\*移除市電。
  - \*控制器插拔任何接頭時
  - \*機台或控制器維修時
- b. 關閉電源後，請於30秒後再重新送電。

In addition, this product provides DC12V/40mA and three sets of DC24V/80mA, DC24V/4.2A power for sewing machine lightings, solenoid valves and solenoid use. Finally, to ensure user safety, the product protecting functions are as follows: high & low voltage alarm, driver module over-temperature alarm, motor encoder error alarm, over-current alarm, motor stall alarm or machine, +24 V low voltage abnormal alert.

(2)system specification

- Motor type: AC servo motor
- Input voltage: AC 200V-240V
- Input frequency: 50Hz-60Hz
- Motor output power: 350W
- Motor output torsion:0.577N-mat6000rpm
- Motor maximum output speed: 6000rpm
- Motor minimum output speed: 200rpm
- Motor speed increase and decrease time: below 2000ms
- Lighting specification: DC12V/40mA
- Solenoid valve specifications: 24V/80mA
- Solenoid Specifications: 24V/4.2A within 100ms

(3)Notes

- a. Remove power supply when performing following actions
  - \*Installing the controller
  - \*Plugging controller into any connector
  - \*Maintaining machines or controllers
- b. After the power is turned off, please wait for 30 seconds to return the power.

## 操作環境照明

提供一個警示標誌，告知使用者：工業用縫紉品或是縫紉系統必須在該縫紉區域未啟動照明裝置前，禁止插電或通電；照明裝置的最大輸入功率應該能夠輕易辨識，當照明裝置被重置或移動的時候，警示標誌也應設置在照明裝置插座上或是附近。警示標示如圖所示。

(Fig.48)

## LIGHTENING OF THE OPERATION ENVIRONMENT

Provide a warning that an industrial sewing unit or sewing system must always be unplugged from the local lighting of the sewing area before relamping, the marking of maximum rated input of lamp shall be easily discernible while the lamp is being replaced indicated on or near the lamp socket as shown on. (Fig.48)



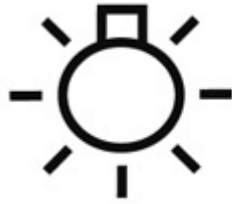

最大流明 → 510流明  
最小流明 → 430流明

Maximum → 510Lum  
Minimum → 430Lum

圖48/Fig. 48

## 操作者條件

## CONDITIONS OF ALL OPERATORS

1. 熟讀並了解使用說明書內容。
2. 認識機器各部功能及注意事項。
3. 了解各警告標籤之意義。
4. 了解熟悉機器之操作方式。
5. 操作者須保持精神狀態良好。
6. 操作者須穿著合宜適當之工作服。
7. 視需要培養操作者使用機器之熟練度。

1. Read and understand well the content of this instruction book.
2. Know the functions of major parts and understand the notices
3. Truly realize the meanings of all warning tags
4. Realize and be familiar with how to operate this machine.
5. Operators have to keep well mental status.
6. Operators shall wear appropriate and proper working suits.
7. Develop the familiarity of how to operate the machine if needed.

## 保養

## MAINTENANCE



### 注意CAUTION



清潔作業前，請切斷電源。當誤觸啓動開關時，縫紉機動作易導致人員受傷。  
Turn off the power switch before carrying out cleaning. The machine may operate if the treadle is pressed incautiously, which could result in injury.



加潤滑油和黃油時，務必戴好保護眼鏡和手套，以防潤滑油進入眼中或沾在皮膚上，易引起發炎。  
Be sure to wear protective goggles and gloves when handling the lubricating oil and grease so that they do not get into your eyes or onto your skin, otherwise inflammation can be resulted.



潤滑油或黃油不能飲用，否則將會引起嘔吐和腹瀉，將油放在小孩拿不到的地方。  
Furthermore, do not drink or eat the oil nor the grease for they can cause vomiting and diarrhea. Keep the oil away of the reach of children.

縫紉機頭倒下或豎起時，請以雙手進行操作。  
Use both hands to hold the machine head when tilting or returning it to its original position.



單手操作時，因縫紉機的重量較重，萬一滑落易導致受傷。  
If only using one hand to move the machine, the weight of the machine head may cause slipping and you may get hurt.

保養循環 Maintenance Cycle	保養項目 Maintenance Items
每天 Daily	1. 清潔送料具上之棉絮 1. Clean the lint on the feed dog.
	2. 檢查油盤是否有足夠之液態油。(油量在油鏡之上、下兩紅漆記號間) 2. Check if there has enough liquid oil inside the oil pan. (The amount should be between the red up and down paint mark of the oil level gauge.)
	3. 保持機器及操作台清潔 3. Keep the machine and the operation table clean.
	4. 清潔手輪濾網上之棉絮 4. Clean the fiber on the filter net of the hand wheel.
每週 Weekly	1. 保持電源外觀乾淨 1. Keep the power cords looking clean and neat.
	2. 保持操作面板乾淨 2. Keep the operational panel clean
	3. 檢查電源零件是否鬆脫或在正確位置 3. Check if the power parts is loosening or still at the right position
每三個月 Quarterly	1. 更換油盤內之液態油 1. Change the liquid oil inside the oil pan
每年 Annually	1. 檢查傳動皮帶是否疲乏或毀損 1. Check the transmission belt to see if it is weariful or damaged.

表11/Table11

故障檢修

TROUBLESHOOTING





注意CAUTION



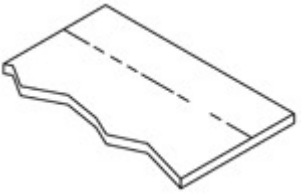

在進行故障查詢之前，請先關閉電源並拔出電源，否則如果誤觸起動開關，縫紉機會動作，易導致人身傷害。

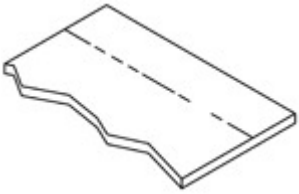
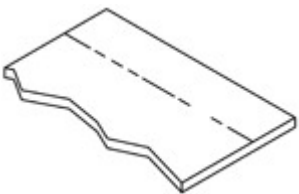
Turn off the power switch and disconnect the power cord before carrying out troubleshooting. The machine may operate if the treadle is pressed incautiously, which could result in injury.

No.	現象 Problem	檢查及調整 Exam and Adjustment
1.	針線太過緊密 / 鬆疏 Needle thread too tight / loose 	Q: 針線張力是否過大或過小？ A: 調整針線張力。 Q: The tension of the needle thread is too loose or too tight? A: Adjust the needle thread tension
2.	針線的跳線現象 	Q: 車針的選擇不對？ A: 選擇配合布料的車針與縫線號碼。 Q: Choose the wrong needle? A: Select the needle and thread number match the fabrics Q: 車針不良？ A: 換新車針。 Q: Bad needle? A: Change a new needle Q: 車針與左勾針尖端之間有間隙？ A: 調整左勾針尖端與車針之間士±0 Q: Any clearance between the needle and the top of the left looper? A: Adjust the distance from the top of the left looper to the needle to be ±0 Q: 張力調整小彈簧不起作用？ A: (1.) 小彈簧不起作用時，要把彈簧拉緊一點。（注意）拉太長則會發生斷線。 (2.) 張力調整體發生溝槽時，則須更換新調整盤。 Q: The small spring of tension adjustment does not function? A: (1.) If the small spring does not function, pull it to be more tightened. (Note) The broken thread will happen if pull the spring too tight. (2.) If there is any groove existing on the tension adjusting plate, please change a new one. Q: 針線的張力太緊？ A: (1.) 把針線張力適度調整。 (2.) 把針線的線路（A）調整在最高位置，使針線的勾線器（B）的針線放出量減少。 (3.) 把線路（C）左傾一點，以增加勾針的線放出量。 Q: The tension of the needle thread is too tight? A: (1.) Loose the tension of the needle thread properly. (2.) Adjust the line (A) of the needle thread to the highest position, so that the release amount of the needle thread from thread hooking will decrease. (3.) Lean the line (C) to left a little to increase the release amount of the looper thread.

No.	現象 Problem	檢查及調整 Exam and Adjustment
3.	右勾針線的跳線 The Skipping Stitch of the Right Looper Thread 	Q: 右勾針與車針的間隙太大？ A: 右勾針向右退後時，和車針的間隙必須為0.1mm 乃使用正規的右勾針。（備有單針、雙針、厚料、薄料用各機種最合適的右勾針） Q: The space between the right looper and needle is too wide? A: When the right looper turn right and backward, the distance to the needle has to be 0.1 mm, which is using the correct right looper. (The appropriate right looper for each type, such as single need, 2 needles, materials, and thin fabrics, are included) Q: 雙針時，右勾針與左針的間隙大？ A: 由於右勾針安裝時的左右位置以及右勾針座上下運動位置之雙方關係，予以調整在勾針的運動軌跡，在右勾針下降時，將左針到右針的下降量予以減少。 Q: The distance is too wide between the right and left needle when using 2 needles? A: Because the correlationship of the left/right position of the right looper while assembling and the up/down moving position of the right looper seat, adjust the movement path of the looper. When the right looper descends, decrease the descending amount from left needle to right needle.
4.	左勾針線的跳線 The Skipping Stitch of Left Looper 	Q: 左右勾針交叉時，右勾針不會勾到左勾針線？ A: 換新左勾針。（左勾針尖端磨損，要修正時，不得把頭部凸出處予以磨低（磨薄）。 Q: The right looper didn't hook the left looper thread while they are crossing each other? A: Change the new left looper. (The top of the left looper is worn. When fix and replace, the protrusion of the looper top shall not be worn. Q: 右勾針尖端的磨損？ A: 換新勾針或用油石把尖端磨尖。 Q: The wear of the right looper top? A: Change a new looper or use the oil stone to wear the top.
5.	斷針 Needle Broken 	Q: 車針的選擇不對？ A: 在布料不發生針孔的範圍內，使用粗一點的車針。 Q: Choose the wrong needle? A: Use thick needle within the range that there will be no pinhole occurred on the fabric. Q: 押具的安裝不良？ A: 安裝時必須使用車針會插進押具落針處中央。 Q: Bad assembling of the presser foot? A: During assembly, make sure the needle can insert to the central point of the presser foot.

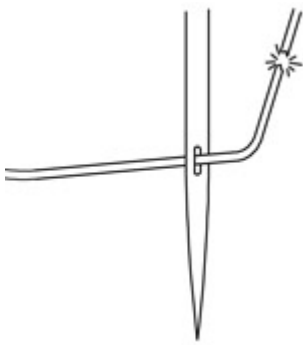
No.	現象 Problem	檢查及調整 Exam and Adjustment
		<p>Q: 送布齒的安裝高低不對？  A: 調整送布齒的高度為 0.8mm — 1mm，同時保持適當的押具壓力。</p> <p>Q: Wrong assembling height of the feeding teeth?  A: Adjust the height of the feeding teeth to be around 0.8 mm to 1 mm. Meanwhile, keep the appropriate presser foot pressure.</p> <p>Q: 縫線不良？  A: 縫線有結頭要事先加以處理後，重新穿線。</p> <p>Q: Bad threading?  A: If there is any connecting part of the thread, it needs to be dealt first. Then, rethreading.</p>
6.	<p>車針尖端受損  The Top of the Needle Damaged</p> 	<p>Q: 右勾針及車針高低不對？  A: 車針在上死點附近時，用手指故意把車針向前彎曲，看看尖端會不會碰到右勾針，然後調整車針高低或右勾針的運動位置。</p> <p>Q: The right looper and the needle have wrong height position?  A: When the needle moves close to the upper dead point, push the needle forwards a little by finger. See whether the top of the needle touches the right looper or not. Then adjust the height of the needle position or the moving position of the right looper.</p> <p>Q: 頂針片太靠近？  A: 裡面的頂針片必須在左勾針的尖端到達車針右側面時，就要從車針離開。前面頂針片與車針的間隙必須留大約0.2mm。</p> <p>Q: The ejector plate is too close?  A: The ejector plate inside must leave from the needle before the top of the left looper reaches the right side of the needle. The distance between the front ejector plate to the needle is about 0.2 mm.</p> <p>Q: 針板安裝位置不對？  A: 把針板拉前安裝使 A 部分的間隙大一點。</p> <p>Q: Incorrect needle plate assembling position?  A: When assembling the needle plate, pull it forwards a little so that the space of part A can be larger.</p>
7.	<p>斷線與縫合不順  Broken Thread and Rough/Uneven Stitch</p>	<p>Q: 線架的線孔沒有磨光？  A: 用砂布把線孔周圍磨光。</p> <p>Q: The thread hole of the thread stand did not polish?  A: Use emery cloth to polish the surroundings of the thread hole.</p> <p>Q: 線的選擇錯誤？  A: 更換較好的線，使粗細線均勻。</p> <p>Q: Choose the wrong thread?  A: Change a better thread to balance the threads.</p>

No.	現象 Problem	檢查及調整 Exam and Adjustment
		<p>Q: 線的張力調整不好？  A: 注意左右勾針的線不要太鬆，要調整一支針線時也要注意有關的線變化。  (1.) 拉緊針線 → 左勾針線會鬆 → 右勾針線會緊。  (2.) 拉緊左勾針線 → 右勾針線會鬆 → 針線也會鬆。  (3.) 拉緊右勾針線 → 左勾針線會鬆 → 針線會鬆。  Q: Cannot adjust to the best thread tension?  A: Please be noted that the threads of the left/right looper should not be too loose. When adjust the position of one needle, the related changes of the threads are needed to be noticed.  (1.) Pull the needle thread tightly --&gt; the left looper is looser --&gt; the right looper is tighter  (2.) Pull the left looper thread tightly --&gt; the right looper is looser --&gt; the needle thread is looser, too.  (3.) Pull the right looper thread tightly --&gt; the left looper thread is looser --&gt; the needle thread is looser.</p> <p>Q: 押具彈簧調整不良？  A: 調整押具彈性配合所要用的布料  Q: Incorrect adjustment of the presser foot spring?  A: Adjust the presser foot flexibility to fit the fabric.  Q: 切刀磨損？  A: 磨利刀口或更換新品。  Q: The knife is worn?  A: Sharpening the knife or changing a new one.  Q: The differential ratio not match?  Q: 差動比未配合？  A: 調整配合布料的差動送料。  Q: The differential ratio not match?  A: Adjust the differential feeding to match the feeding fabric.</p>
8.	<p>環縫不出線  The Thread does not Come Out When Doing Chainstitch</p> 	<p>Q: 環勾針線凸輪調整不當？  A: 調整適當的凸輪方位。  Q: The cam of the chain stitch looper is not appropriate?  A: Adjust the cam to an appropriate position.  Q: 控線器不良？  A: (1.) 調整彈簧強度  (2.) 拋光或換新  Q: Thread tension device does not work well?  A: (1.) adjust the spring strength  (2.) polishing or changing a new one  Q: 押具後彈簧安裝不良？  A: 重新調整彈簧或換新，使押具活動自如，並試其壓力。  Q: The presser foot rear spring did not assemble well?  A: Read just the spring or change a new one to make sure the presser foot can act smoothly and test its pressure.</p>

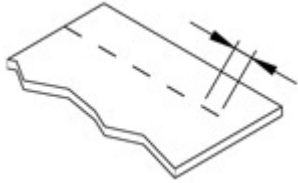
No.	現象 Problem	檢查及調整 Exam and Adjustment
9.	粗細針不能分 Cannot Separate the Thin and Thick Thread 	Q: 偏心凸輪生鏽? A: 清除阻塞部分使油通到凸輪上。 Q: The eccentric is rusty? A: Clean the stuck part so the the oil can reach the cam. Q: 偏心凸輪控制彈簧調整不當? A: 調整適當之緊度，但不可太鬆。 Q: Inappropriate adjustment of the eccentric cam control spring? A: Adjust to the proper tension, but should not be too loose. Q: 與止輜淪配合之滑塊配合不當? A: (1.) 校正 KP09D 寬度或磨小 KP06F 寬度。 (2.) 便換 KP09D / KP06F Q: Inappropriate match with the slide block of the stopper cam? A: (1.) Correct the width of KP09D or polish the width of KP06F short. (2.) Change KP09D / KP06F
10.	大聲、異聲 Loud Noise, Strange Noise	Q: 布板聲? A: (1.) 調整螺絲適當位置 (2.) 調整 KB06E 的 NK26 使布板蓋側蓋靠穩 Q: Sound of fabric Plate? A: (1.) Adjust the screw to the proper positon (2.) Adjust Nk26 of KB06E to stablize the side cover of the fabric plate cover. Q: 心軸鬆動出聲? A: 把大心上的銅套之銅面膠清除，重新調整。 Q: The main shaft is loose and has noise? A: Clean the copper glue from the copper cover of the main shaft and readjust. Q: 泵浦聲（沙沙聲）? A: 用治具加壓泵浦齒輪，使運轉3~5分鐘即可。 Q: Noise of the pump (scratchy?) A: Use the fixture to add pressure on the gear of the pump, and keep the pump running 3-5 minutes. Q: 針棒鬆動 A: 更換新品或磨合其接觸面使之間隙變小。 Q: The needle bar is loosening? A: Change a new one or to polish the contacting surfact so that the clearance is smaller. Q: 連桿上控制間隙之固定勾鬆動、碰撞? A: (1.) 螺絲加膠 (2.) 溝寬磨大或導角 (3.) 更換新品 Q: The fixed hook of the connecting rod controlling the clearance is loosening or clashing? A: (1.) Add glue onto the screw (2.) Polish the goove width wider or chamfer (3.) Change a new one.

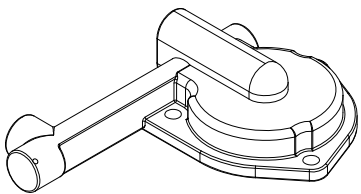
No.	現象 Problem	檢查及調整 Exam and Adjustment
		Q: 上下刀位置不對？ A: 調整上刀下刀角度。 Q: Incoorect position of the upper and the lower knife? A: Adjust the angles of the upper and the lower knife. Q: 布板蓋之側蓋碰撞聲？ A: 校正布板蓋之側蓋的角度，使之不會撞到下勾針與上刀台。 Q: Crashing noise form the side cover of the fabric plate cover? A: Correct the angle of the side cover of the fabric plate cover to keep it from the lower looper and the upper knife seat.
11.	不能噴油 The Oil Does Not Splash 	Q: 泵浦不出油？ A: (1.) 重新鎖正確位置 (2.) 重新組配泵浦中齒輪與已軸位置 Q: The oil does not come out from the pump? A: (1.) Relock it to the correct position (2.) Reassemble the gear of the pump to the main shaft and adjust the position. Q: 上機構不噴油？ A: (1.) 清除毛頭換新出油螺絲 (2.) 換新濾油器 (3.) 清除污穢的東西或換新 (4.) 用鐵絲疏通油路 Q: Upper mechenism does not splash the oil? A: (1.) Clean the lints and change the oil releasing screw. (2.) Change a new filter (3.) Clean the dirt or change a new one (4.) Use the iron wire to clean through the oil path.

圖表2/Chart2

## 控制箱故障排除

## CONTROL BOX TROUBLESHOOTING

警示LED為綠色燈表示控制器正常運作，紅燈表示控制器異常，使用者可以藉由五秒內閃燈的次數判斷問題發生的原因，如下表所示：(表12)

Green color LED represents the controller is working well and the red color represents the abnormal controller. User can determine the cause by observing the blinking frequencies within 5 seconds. (Table12)



紅燈閃燈 次數 Red LED Blinking	說明 DESCRIPTION	故障排除 TROUBLESHOOTING
01	<p>溫度感測元件發生故障時，MCU會偵測出不符合規格之溫度，此時MCU則判定為感測元件異常，Motor不再啟動。</p> <p>Awhen temperature sensor fails, MCU will detect that the temperature does not meet specifications, thus MCU is judged to be abnormal, and the Motor will not start.</p>	<p>步驟1: 關閉電源後, 再重新開啟電源。 Step1: Turn off the power, and turn on the power again.</p> <p>步驟2: 故障無法排除，請更換控制基板。 Step2: If faults cannot be solved, please replace the control board.</p>
02	<p>檢知Bulk voltage發生最大值時，Motor不再啟動。</p> <p>When detector Bulk voltage detector reaches maximum, Motor will not start.</p>	<p>步驟1: 確認輸入電壓是否異常過高 (280Vac)。 Step1: Confirm if the input voltage is abnormally high (280Vac).</p> <p>步驟2: 故障無法排除，請更換控制基板。 Step2: If fault can not be solved, replace the control board.</p>
04	<p>(1) 控制器檢知Motor運轉電流值 <math>\geq 20A</math>時</p> <p>(1) When Motor controller detects the current value <math>\geq 20A</math></p> <p>(2) V bulk電壓大於470Vdc時，Motor不再啟動。</p> <p>(2) V bulk voltage is greater than 470Vdc, Motor will not start.</p>	<p>步驟1: 檢查負載是否過大?或機構大心卡住? Step1: Check if the load is too large or main shaft is stuck.</p> <p>步驟2: 更換控制器。 Step2: Turn off the power, and turn on the power again.</p> <p>步驟3: 故障仍無法排除，更換馬達。 Step3: During motor abnormal stop protection period, within the fault LED flashes 5 times in 5 seconds</p>
05	<p>馬達encoder訊號因斷線或損毀，導致MCU偵測發生異常，Motor不再啟動。</p>	<p>步驟1: 馬達encoder訊號線是否斷線或損毀。 Step1: Check if motor cable is disconnected or damaged.</p> <p>步驟2: 故障仍無法排除，更換馬達。 Step2: If fault can not be solved, please replace the motor.</p>
06	<p>IGBT藉ON/OFF動作, 呈現近似Sin wave波形控制Motor運轉及動作電流，在Switch動作頻繁及負載電流通過，形成熱損增加與溫度上升。</p> <p>IGBT shows a similar Sin wave form controlling Motor and operating current by the ON / OFF operation, the temperature rises and heat loss increases by frequently switching and load current passing.</p>	<p>步驟1: 檢查是否負載過大?或運轉時間過長? Step1: Check if the load is too large or under long time running.</p> <p>步驟2: 關閉電源後, 再重新開啟電源 Step2: Turn off the power, and turn on the power again.</p> <p>步驟3: 故障無法排除，請更換控制基板。 Step3: If the fault can not be solved, replace the control board.</p>

紅燈閃燈 次數 Red LED Blinking	說明 DESCRIPTION	故障排除 TROUBLESHOOTING
07	電磁鐵 24V異常 (電磁鐵 24V電壓小於12VDC判定異常) 24V solenoid abnormal (When 24V solenoid voltage is below 12VDC, it's determined abnormal.)	步驟1:檢查電磁閥是否故障(機構部分)。 Step1: Check whether the solenoid is malfunctioned (mechanical part) 步驟2: 關閉電源後, 再重新開啟電源。 Step2: Turn off the power, and turn on the power again. 步驟3: 故障無法排除, 請更換控制基板。 Step3: If the fault can not be solved, replace the control board
恆亮 Permanent Bright	因機台零件損毀或不可抗拒因素造成馬達堵轉 When the motor is blocked due to spare part damages or uncontrollable causes.	步驟1:檢查機台是否有異物纏繞手輪上造成卡住或機體有零件損毀或馬達損毀。 Step1: Check whether there's any object winding around the machine, or if there's any spare part damage or motor damage. 步驟2:關閉電源後, 再重新開啟電源。 Step2: Turn off the power, and turn on the power again. 步驟3:故障無法排除, 請更換控制基板。 Step3: If the fault can not be solved, replace the control board.

表12/Table12

註：閃爍時間為0.5秒閃一下，中間間隔1秒

Remark: Blinking endures 0.5 seconds and the interval takes 1 seconds.

桌板圖

TABLE CUT-OUT

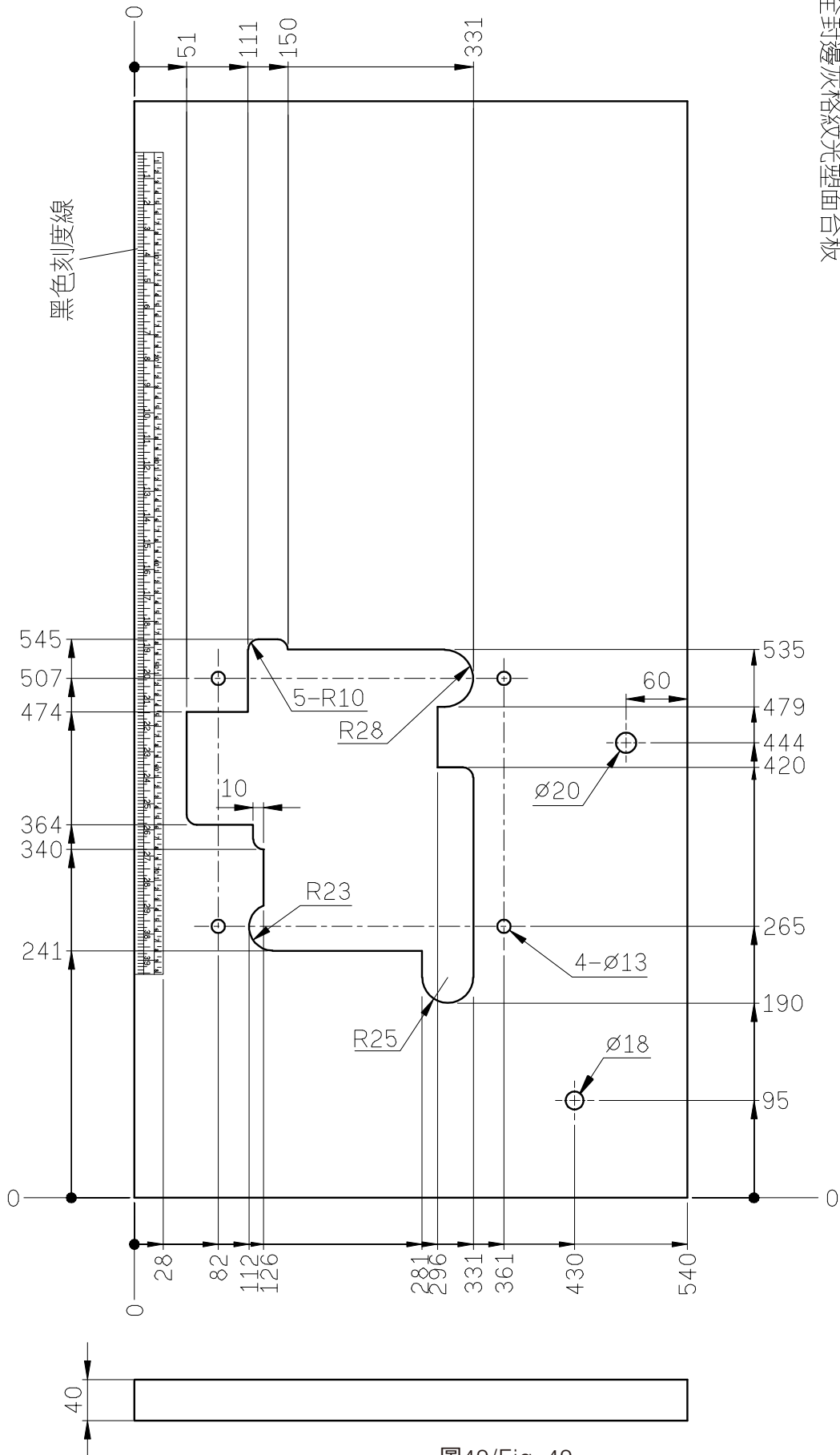

單位/UNIT:mm  
 FOR 700Q/988Q  
 所有尺寸公差/TOLERANCE:±2  
 700Q-T 長度(L):1070/重量:10.3kg±5%  
 700Q-T 長度(L):1200/重量:11.3kg±5%  
 全封邊灰格紋光塑面台板

圖49/Fig. 49



# 桌板圖

# TABLE CUT-OUT

單位/UNIT:mm

FOR 700Q/988Q

所有尺寸公差/TOLERANCE:±2

TB301Q重量:4.25Kg±5%

全封邊灰格紋光塑面台板



圖51/Fig. 51



圖52/ Fig. 52

## 報廢流程

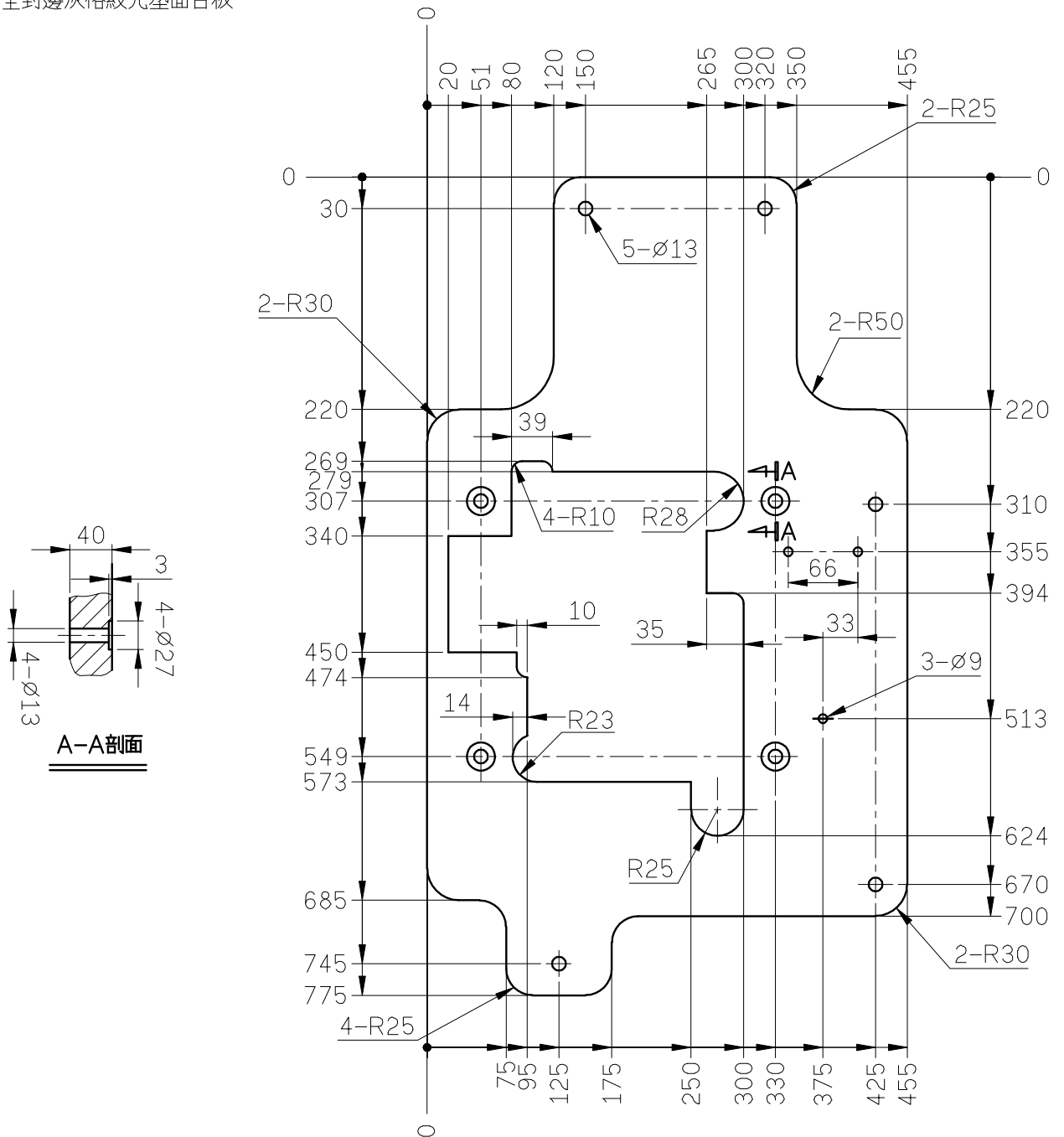
## DEMOLITION PROCEDURE

1. 當機器需要被淘汰與報廢時，有一些基本規則必須採納、遵守以保護環境及公眾健康。
  2. 所有的機器零組件必須依照下列分類來區分開：
    - (1) 所有護套、可伸縮軟管及塑膠或非金屬零件。
    - (2) 電器零件：開關、照明器具等。
    - (3) 絕緣材料：石棉、彈性/可伸縮橡膠片。
    - (4) 金屬：含鐵金屬、銅、青銅與黃銅、其他各種金屬。
  3. 以此方法，所有材質可以正確的淘汰、回收再利用或鎔解為可再使用或再處理而不至於危害環境。
1. When the machine needs to be eliminated and demolished, certain basic rules must be observed to protect the environment and public health.
  2. ALL machine componenets must be divided according to categories as the followings:
    - (1) All sheathes, flexible hosing and plastic or non-metal components.
    - (2) Electricity components: switches, or lighting components.
    - (3) Insulation materials: rock wool, and flexible rubber strips.
    - (4) Metals: ferrous metals, copper, bronze and brass, various.
  3. In this way, all materials can be eliminated correctly, recycled, or melted down for re-use or disposed of so that they do not harm the environment.

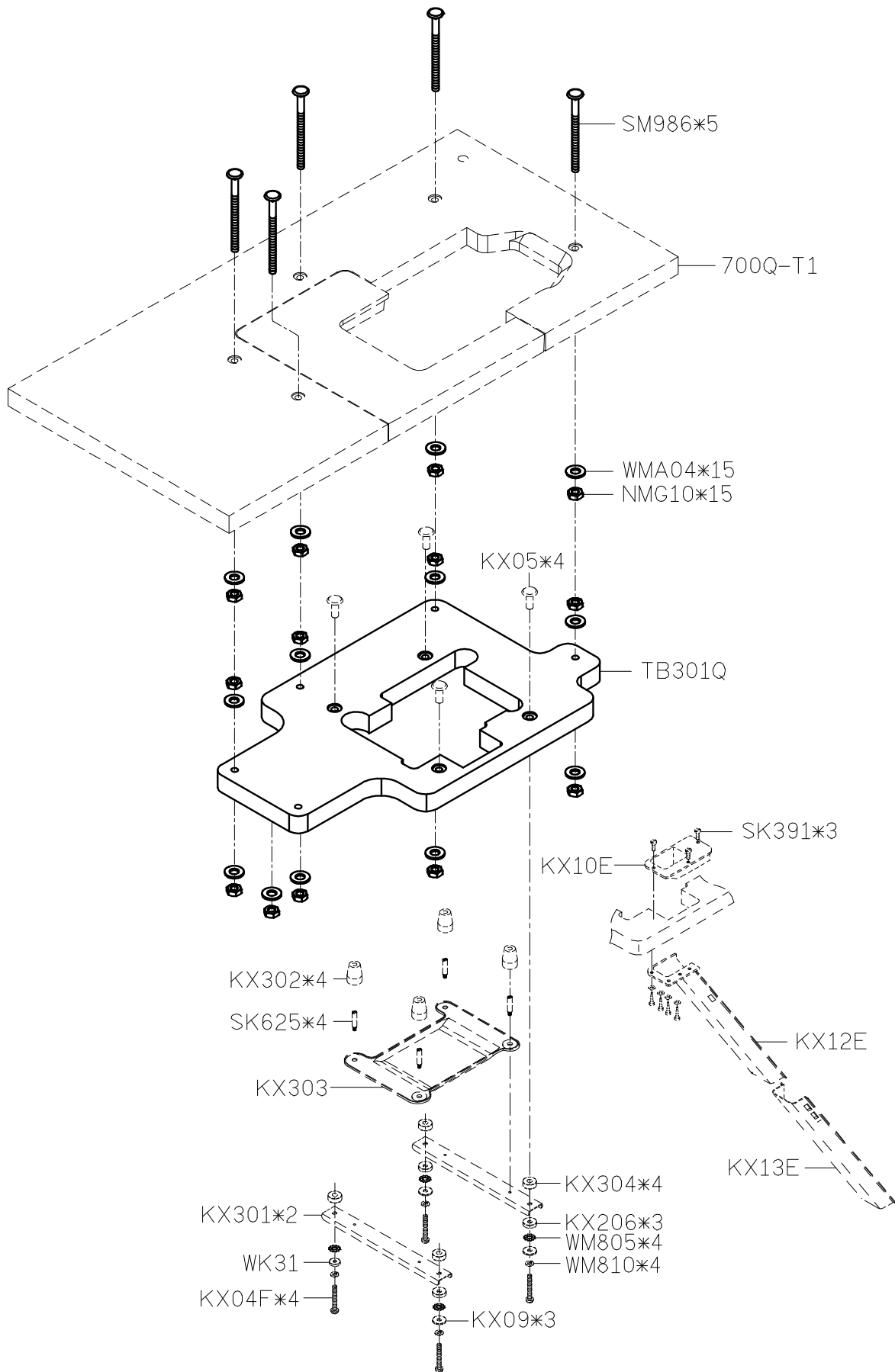

# 700Q/988Q

高林股份有限公司 KAULIN MFG. CO.,LTD.