

SIRUBA[®] Sew Reach

使用說明書與零件圖

INSTRUCTION BOOK & PARTS LIST

■ ASP-EBJ100S

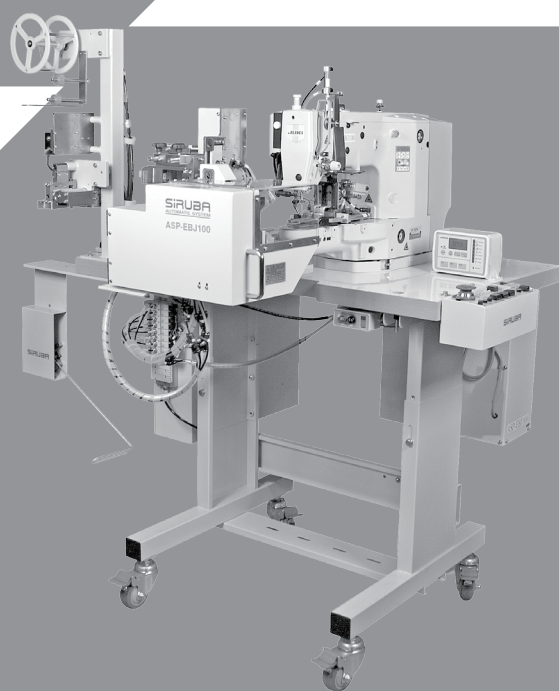

CE

重要安全聲明

•感謝客戶您購買本公司產品

為安全且正確地使用本產品 ASP-EBJ100，請詳細閱讀以下注意事項後再實施操作。

1. 在使用本機器前，請先詳讀說明書內容，必須遵守說明書的指示與規定。
2. 此設備的使用，由經過適當訓練的操作人員實行。
3. 在使用本機器時，若發現異常或故障，應立即停止使用，並切除電源，以進行妥善修理。
4. 嚴格禁止對本機器進行改造和變更。本公司對改造或變更過的機器不予保固，若因此造成危害，本公司將不負任何賠償責任。

•危險

為杜絕觸電事故必須遵守以下安全措施。

1. 安裝本機器時，必須確實做好接地動作。
2. 對本機器的電氣做定檢與維修，都必須由具有資格的電氣技術人員執行，或專家的監督指導下進行。

•警告

為了杜絕觸電、火災、燒損或對人的傷害，必須遵守以下安全措施。

1. 本機器在有電壓的狀態下，絕對禁止人員接觸通電之機件。
2. 本機器若需要做零件更換或進行維修時，應將電源切換至 OFF 狀態。

SAFETY INSTRUCTIONS

•Thank you for purchasing our company's products.

For your safety and using our product ASP-EBJ100 properly, please read the instructions below deliberately, then start operating the machine.

1. Before using the machine, you must follow the instructions and rules.
2. The operators must be well trained.
3. If you found some abnormal phenomena or the machine malfunction, you should stop using the machine at the moment and cut the power off, in order to do the proper repair.
4. Strictly forbid to do the extra transformation or alteration. We do not have the warranty to the machine which had been transformed or altered. Therefore, our company will be irresponsible for any compensation if the machine has caused any danger.

•Hazards

In order to prevent from the electric shock, you must to obey the safety measure below.

1. While install the machine, make sure you have do the grounding.
2. The electric routine inspection and maintenance of the machine have to be done by the electric technical personnel who qualified or under the expert's supervision.

•Alert

You must to obey the safety measure below, in order to prevent from the electric shock, fire accident, burning loss, or human body injured.

1. Absolute forbid workers to touch the machine's parts while the machine is in a voltage state.
2. If the machine's parts need to be changed or do the maintenance, you should switch the power off.

3. 當本機器不能正確工作時，應立即停止操作機器。該機器有必要進行修理、電氣或機器方面的調整時，需要和本公司的代理商或直接與本公司聯繫商談，採取合適的解決措施。
 4. 本機器的的維修、調整須經由適當訓練的技術員或專業人員進行。維修時，需使用本公司所指定的更換零件。
 5. 一般的保修檢查，要由經過適當訓練的人來進行。
 6. 在維修或保養各式氣缸或氣壓相關連動機構時，務必將供應氣源的接頭拔下，在氣壓完全切斷的狀態方可進行。不過，只限於受過適當訓練的技術人員或專業人員進行調整和運行確認時例外。
 7. 該機器準備啟動前，所有的保護蓋必須安裝定位至機器上。
 8. 本機器的內部裝置和控制箱裡不能殘積金屬粉末和灰塵，要定期打掃。
 9. 本機器在運行當中，所有可動部分都絕對不可用手觸碰，或身體（包括頭髮、衣服類）靠近。
 10. 絕對不可用濕手操作，可能造成觸電等重大傷害發生。
 11. 警告提示如次頁圖案，請務必遵守。
3. While the machine cannot operate properly, you should stop operating it immediately. If the machine has the necessity to repair, or do the electric and machine adjustment, you should contact with our factors, or contact us directly, then take the proper resolution.
 4. The machine's maintenance and adjustment need to be done by well- trained technician or professional. You need to use the specific parts from our company while under maintenance.
 5. The repair within the warranty need to be repair by the worker who well trained.
 6. While doing the repair or maintain variety of cylinders and pneumatic actuator associated, you must unplug the supply air source connector before you do the repair and maintenance. However, it could be only done by the well- trained technician or professional.
 7. Before ready to start the machine, all of the protective covers need to be on the position of the machine.
 8. The inner device and the control box of the machine need to be regularly cleaned, in case of any dust or metal filings remains in the machine.
 9. While operating the machine, do not use your hands to touch or let your body to close (including hair or clothes) all of the movable parts.
 10. Do not use the wet hands to operate the machine, it might cause electric shock or other major injured.
 11. Please be sure to follow the alert pictorial markings by next page.

警告圖案表示

INDICATED THE ALERT PICTORIAL MARKINGS

<p>高壓部位 HIGH-VOLTAGE POSITION</p>	 <p>高壓電危險 DANGER</p> <p>注意-請關閉電源10分鐘後始可打開此蓋 TO OPEN THIS COVER: TURN OFF POWER SUPPLYING AND WAIT MORE THAN 10 MINUTES BEFORE OPENING.</p>	<p>務必關閉電源 10 分鐘後始打開電控箱蓋子 Be sure to turn off the power and wait till 10 minutes before opening the control box's cover.</p>
<p>高速運動部位 HIGH SPEED MOTION POSITION</p>	 <p>CAUTION</p> <p>機械作動部份請注意裝上保護裝置 穿線、換線、調整、清潔時請注意關閉電源。 Moving parts may cause in jury. Operate with safety devices. Turn off main switch before threading, changing bobbin and needle, cleaning etc.</p>	<p>謹防工傷事故 In case of industrial accident</p>
<p>高速運動部位 HIGH SPEED MOTION POSITION</p>	 <p>Be careful of its movement. 移動快速 敬請小心</p>	<p>謹防工傷事故 In case of industrial accident</p>
<p>高速運動部位 HIGH SPEED MOTION POSITION</p>		<p>謹防工傷事故 In case of industrial accident</p>

安全注意事項

SAFETY INSTRUCTIONS

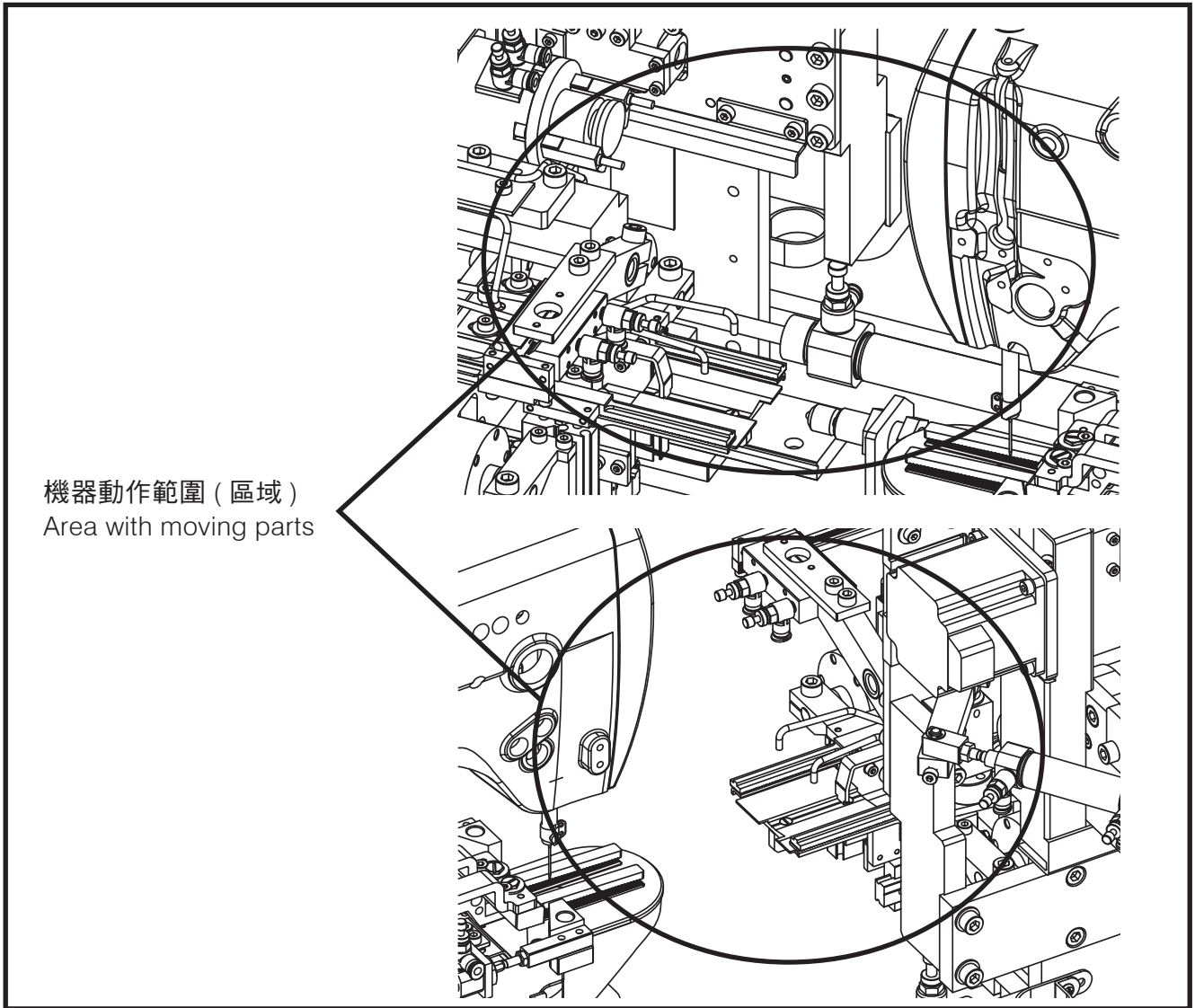

1. 機器在運轉時，不可將手指等放入該區域內。
2. 為了保修、檢修卸掉罩蓋時，必須將電源切到 OFF。

1. Do not put your fingers into the area while machine is operating.
2. Must switch off the power before take down the cover for repair and maintenance.

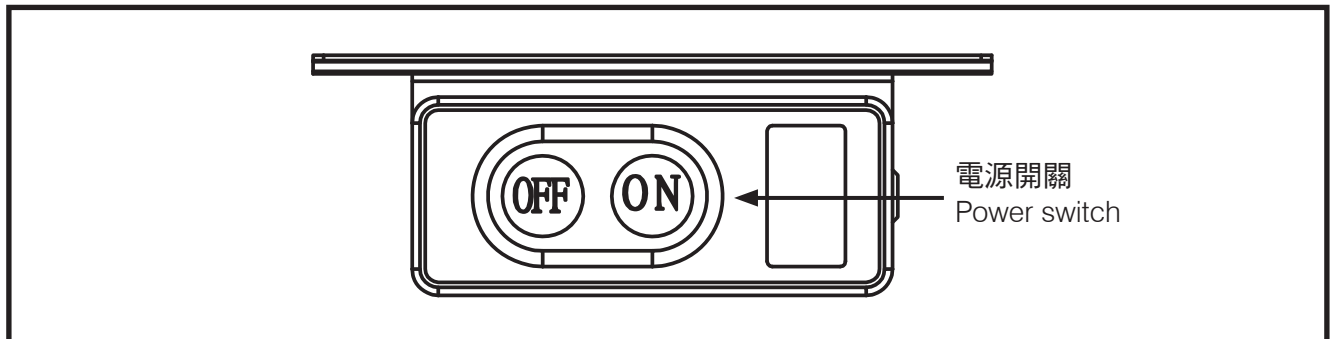

3. 在有危及人體的高壓電處，貼有觸電危險警告標記。在貼有本警告的電器控制部位而需要保修、檢修時，打開罩蓋僅能由專業的電氣技術人員進行。

3. Stick the electric shock alert pictorial marking at high voltage place which may cause human danger. Therefore, only the professional and electric technician could open the cover, while the electric place which have stuck on the alert pictorial marking need to be repair and maintenance.

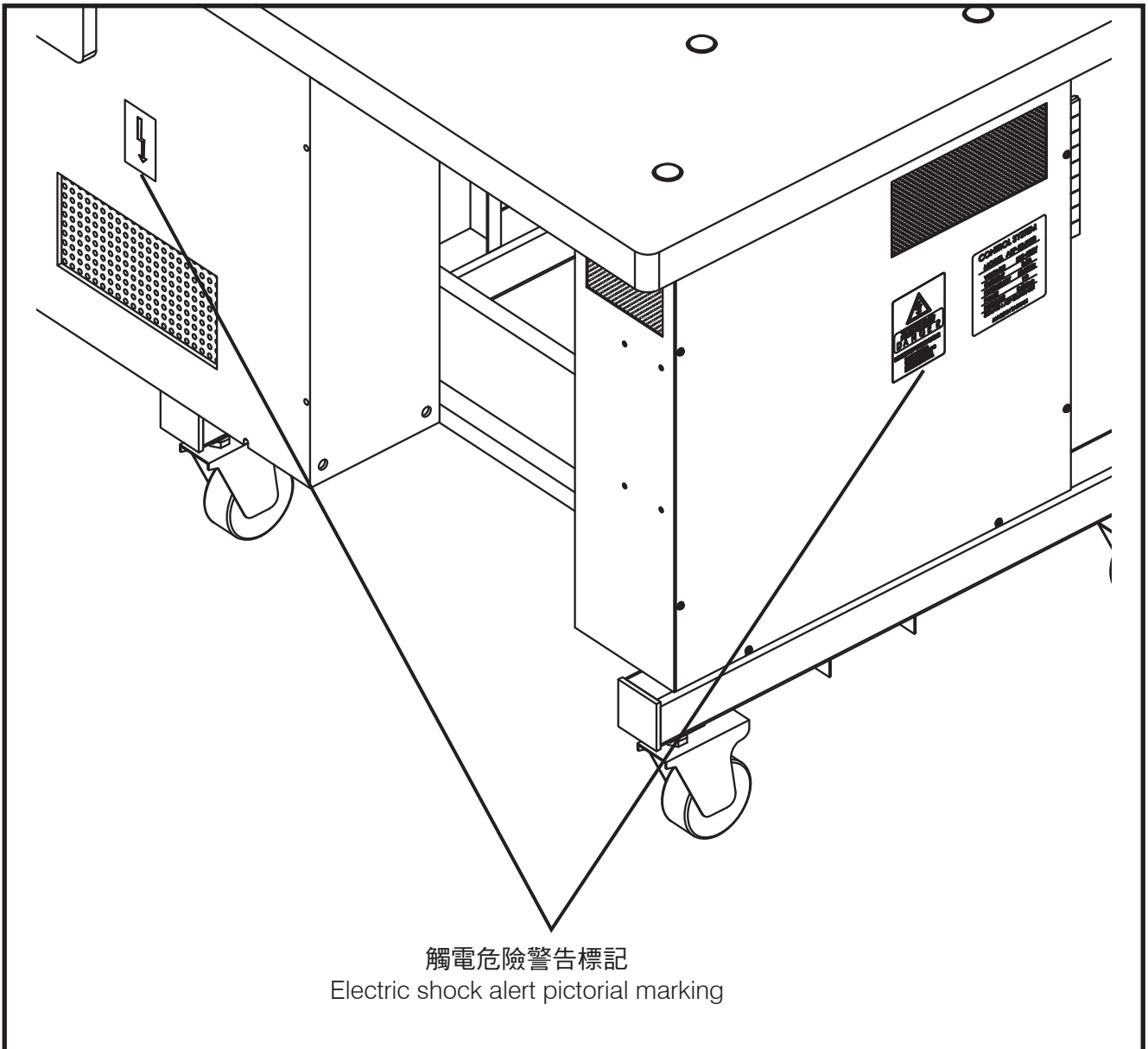

4. 機器運轉時，有必要馬上停止機器的時候，可以按下緊急停機開關。並將（電源開關）切到 OFF。

4. If there's a necessity to stop the machine right away while machine operating, you could press the urgent machine halt switch to switch the power off.

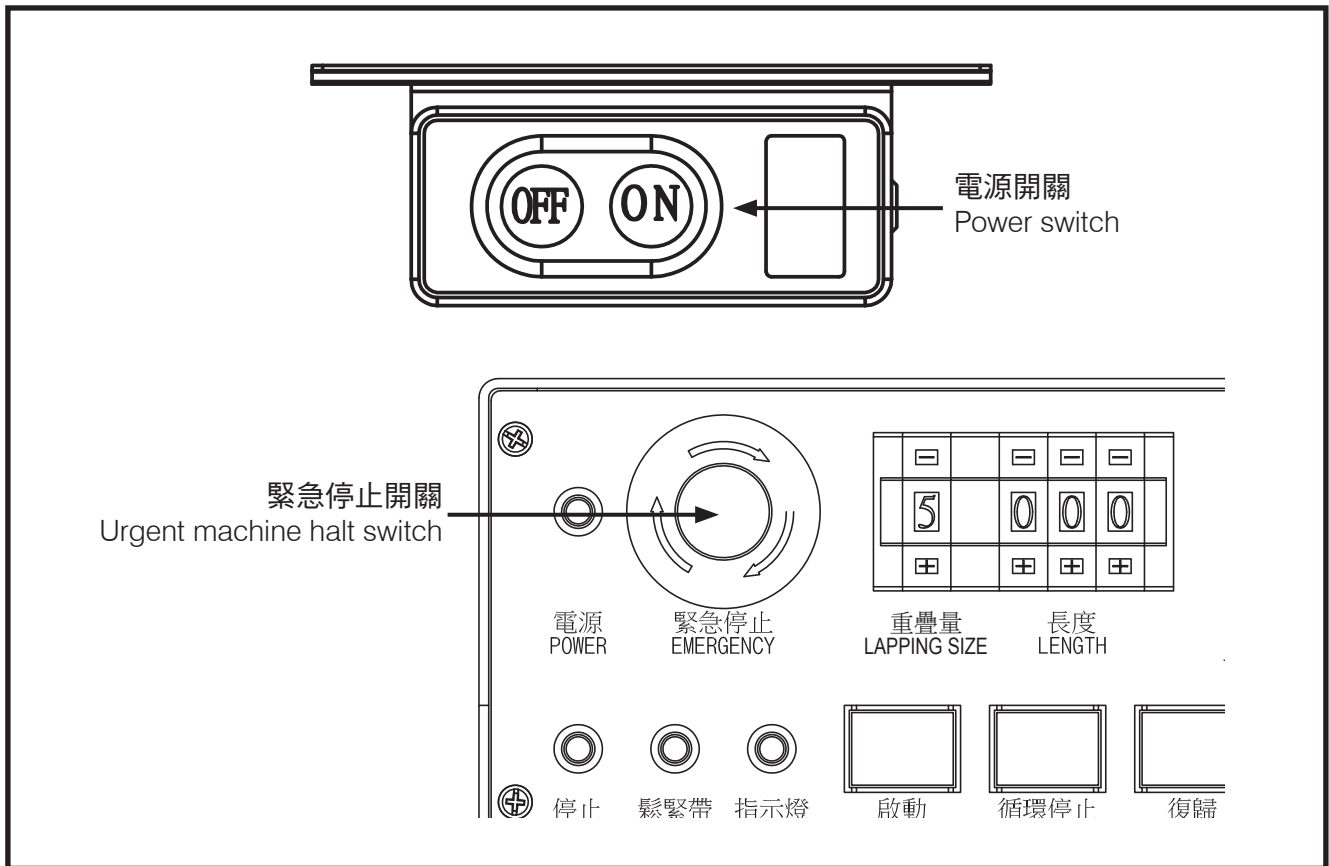

5. 電源線、氣壓管線需確實固定安置，不可散落在地面，以免人員絆倒而發生危險。
 6. 為了生命安全，在任何情況下，不可將電源地線拔掉運轉機器。
 7. 打雷時，為了安全要停止作業，切斷電源。
 8. 離開機器工作地點時或工作結束後一定要將電源開關轉到 OFF。
 9. 機器運轉下，不可卸下罩蓋類。

5. Power cord and pneumatic line pipe need to make sure being fixed and settle down. Do not put them disordered on the ground in case of people stumble and cause danger.
 6. No matter under any circumstances, for your life safety, do not pull out the power ground wire while operating the machine.
 7. For your safety, you need to stop your work and cut off the power, if it starts thundering.
 8. Must switch off the power before you leave your work or work ending.
 9. Do not take down any cover while operating the machine.

索引	INDEX	頁 /PAGE
規格	SPECIFICATION	1
安裝	INSTALLATION	2
操作開關	OPERATION SWITCH	3
(1) 開關說明	(1) ILLUSTRATION OF SWITCH	3
(2) 指示燈的說明	(2) ILLUSTRATION OF INDICATOR LAMP	5
(3) 縫紉機操作面板	(3) OPERATION PANEL OF SEWING MACHINE	6
機器啟動準備	PREPARATION OF OPERATING MACHINE	6
(1) 確認裝置高度	(1) CHECK THE HEIGHT OF THE DEVICE	6
(2) 氣壓	(2) PNEUMATIC PRESSURE	7
(3) 電源電壓	(3) POWER SOURCE VOLTAGE	7
(4) 加油	(4) LUBRICATION	7
鬆緊帶的穿法	WAY TO THREAD THROUGH ELASTIC TAPE	7
更換鬆緊帶方法	WAY TO REPLACE ELASTIC TAPE	9
啟動	OPERATION	10
(1) 設定縫紉花樣圖形以及調整圖形長度	(1) SETUP SEWING PATTERN AND SEWING LENGTH ADJUSTMENT	11
(2) 設定及調整鬆緊帶長度	(2) ELASTIC LENGTH SETUP AND ADJUSTMENT	13
(3) 重疊量設定值	(3) LAPPING SIZE SETUP RATIO	13
(4) 鬆緊帶前端的設定	(4) POSITION FOREFRONT OF ELASTIC TAPE	14
(5) 啟動機器	(5) STARTING	14
(6) 連續運轉	(6) CONTINUOUS OPERATION	15
(7) 僅製作一個成品	(7) SEWING ONE PIECE ONLY	15
(8) 重新安裝鬆緊帶	(8) REPOSITION ELASTIC TAPE	15
調整接合對位及重疊部分	ADJUST BUTTED SEAM & LAPPING SEAM	16
(1) 接合部分的調整	(1) ADJUST BUTTED SEAM	16
(2) 調整重疊範圍	(2) ADJUST LAPPING SEAM	18
指示燈的表示及解除	THE REPRESENTATION OF INDICATOR LAMP & CANCELLATION	19
維護用運轉模式	MAINTENANCE OPERATING MODE	23
(1) 縫製一個帶圈的連續動作	(1) ONE SHOT OPERATING FOR AN ELASTIC RING	23
(2) 機器獨立運轉	(2) MACHINE ISOLATED OPERATION	24
各部分的調整•維護	THE ADJUSTMENT & MAINTENANCE OF EACH PARTS	24
(1) 鬆緊帶定位及送帶設備的前後位置	(1) FORE AND REAR POSITION OF ELASTIC TAPE LOCATING AND FEEDING DEVICE	24
(2) 帶端接合位置偏離調整	(2) ADJUST DEVIATION OF TAPE SIDE END JOINT	26
(3) 氣壓的強度調整	(3) ADJUSTMENT OF PNEUMATIC INTENSITY	26
(4) 輸送滾輪的調整	(4) ADJUSTMENT OF FEEDING ROLLER	27
(5) 機器壓腳及托布板的調整標準	(5) ADJUSTMENT STANDARD OF MACHINE PRESSER CRAMP AND FABRIC HOLDING PLATE	27
(6) 接縫檢測器或是鬆緊帶殘餘量感應器	(6) JOINT SEAM DETECTOR OR ELASTIC TAPE REMAINS SENSOR	28
(7) 切帶刀的更換及調整	(7) REPLACING KNIFE AND ADJUSTMENT	29
零件圖	PARTS LIST	31
選配圖	CHOOSE PARTS	51

規格

SPECIFICATION

型號 Model	ASP-EBJ100S
使用針型 Type of needle	DP x 5 # 14
縫製速度 Sewing speed	2500rpm (最高 /Highest)
生產能力 Output capability	視縫製針數而定 (舉例) 71 針縫製樣式的情形下 8 秒/回 Depends on the stitches (Ex:) 71 stitches thread pattern: 8 sec/cycle
寬度 Width	6mm ~ 20mm
電源 Power source	單相/3相 200~240V 50/60Hz 3.5A(最大) single-phase / 3phase 200~240V 50/60Hz 3.5A(Highest)
氣壓 Pneumatic pressure	0.5 MPa
空氣消耗量 Air consumption	30L/分 30L/min
機器尺寸 Dimensions	寬 1230X 長 1030X 高 1420mm (W)1230X(L)1030X(H)1420mm
縫紉尺寸 Sewing size	<p>重疊尺寸 0~13mm Lapping size 0~13mm</p> <p>兩折長度 150~990mm Two folding length 150~990mm</p>
兩折長度 Two folding length	150~990mm (鬆緊帶圓周長度 300~1980mm) 重疊尺寸 0(對合)~13mm 150~990mm (elastic tape circumferences 300~1980mm) Lapping size 0(fold)~13mm

安裝

INSTALLATION

※ 注意：安裝作業需兩人以上執行。

- (1) 卸下①的兩個螺絲，將擴充檢測部分②暫時分離；這時，另一個人用手托住將擴充檢測部分②，往圖示的方向移動③。（注意請勿損傷擴充檢測部分②的電線）
- (2) 將擴充部分④裝在桌面上之⑤的位置。

※ Caution : The installation work need two or more people to work on.

- (1) Take down two screws of ①, temporarily dispart the feed detecting part ②. At the moment, the other person use hands to hold the feed detecting part ② and move to the direction ③ on the picture. (Be aware do not damage wires of the feed detecting part ②)
- (2) Install the feeding part ④ onto table ⑤.

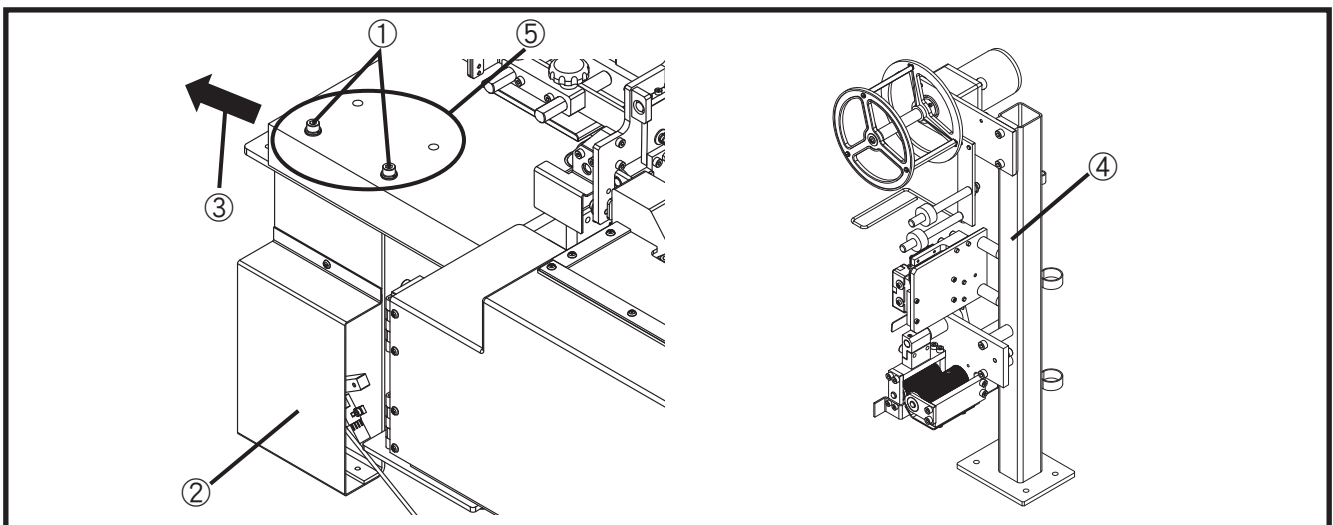

- (3) 用剛開始卸下的兩個螺絲①和配件盒內的兩個螺絲將擴充部分③跟擴充檢測部分②固定。
- (4) 將所有插頭和插座連接。（確實卡住）

- (3) Use two screws of ① at the beginning you took down and the other two screws in the accessory box to fix the feeding part ③ and the feed detecting part ②.
- (4) Plug all the plugs in the sockets. (Make sure them all be fixed.)

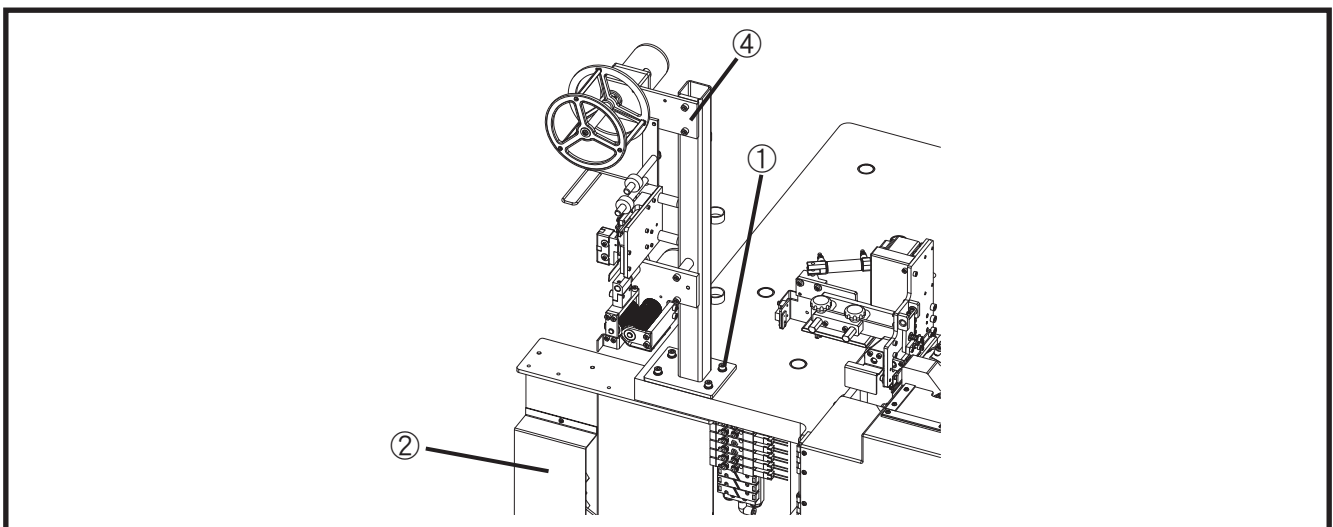

操作開關

OPERATION SWITCH

1. 開關說明

1. Illustration of Switch

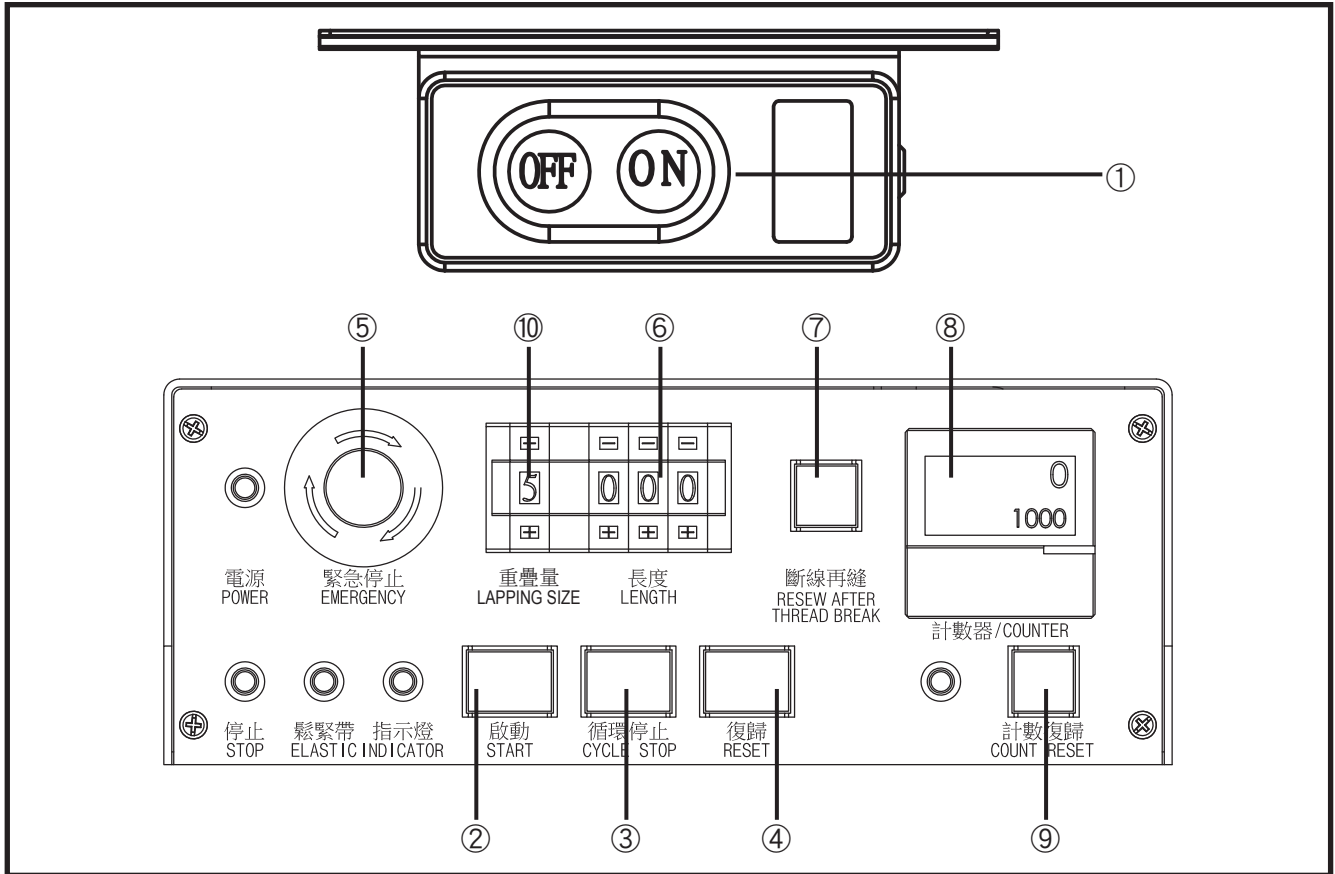

名稱 Names	功能 Functions
①「電源」開關 「Power」switch	電源的開啟 (ON/OFF) Switch power on (ON/OFF)
②「啟動」開關 (綠) 「START」switch (green)	1. 啟動機器。(P.14) 2. 連續運轉的開始。(P.15) 3. 啟動「縫製一個帶圈的連續動作」。(P.23) 1. Start the machine.(P.14) 2. Start to continuous operation.(P.15) 3. Start one shot operation for an elastic ring. (P.23)
③「循環停止」開關 (黃) 「CYCLE STOP」switch (yellow)	1. 連續動作停止。(P.15) 2. 單一成品製作。(P.15) 1. Stop the machine cycle. (P.15) 2. Sewing one product only. (P.15)

<p>④「復歸」開關(藍) 「RESET」switch(blue)</p>	<p>1. 解除錯誤。 2. 長按時可重新設定鬆緊帶。(P.14) 3. 縫紉機單獨運轉的時候(P.24)可控制壓腳升降。 1. Cancel the error. 2. Press the button over seconds can reset elastic tape. (P.14) 3. Operate sewing machine isolated (P.24) can control presser foot lifter up and down.</p>
<p>⑤「緊急停止」開關(紅) 「EMERGENCY」switch (red)</p>	<p>立即停止機器。順時鐘方向轉動可解鎖除。(P.15) Stop the machine immediately. Turn the switch clockwise can release lock. (P.15)</p>
<p>⑥「長度」設定開關 「LENGTH」setting switch</p>	<p>製品完成的長度設定。(P.13) Setting the finished product's length. (P.13)</p>
<p>⑦「斷線再縫」 「RESEW AFTER THREAD BREAK」</p>	<p>斷線後重新車縫。(P.19) Re-sewing after broken-thread. (P.19)</p>
<p>⑧「計數器」 「COUNTER」</p>	<p>1. 計算生產的成品數量。(也可當底線的計數器)※ 2. 計算數位(上段數位)和設定數位(下段數位)一樣時機器會自動停止。(P.19) 1. Count the production volume. (useable for the under thread number.) ※ 2. Machine would stop automatically when counts number(upper numbers) as same as preset counts (lower numbers) (P.19)</p>
<p>⑨「計數復歸」開關(藍) 「COUNT RESET」switch (blue)</p>	<p>使「計數數位」的數值歸零。(P.21) Reset the「COUNTER」value to zero. (P.21)</p>
<p>⑩「重疊量」設定開關 「LAPPING SIZE」setup switch</p>	<p>微調鬆緊帶的右前端位置。標準值「5」。(P.13、16、17、18) Fine adjust the elastic tape's right-forefront position. Standard「5」. (P.13、16、17、18)</p>

2. 指示燈的說明

2.Illustration of indicator lamp

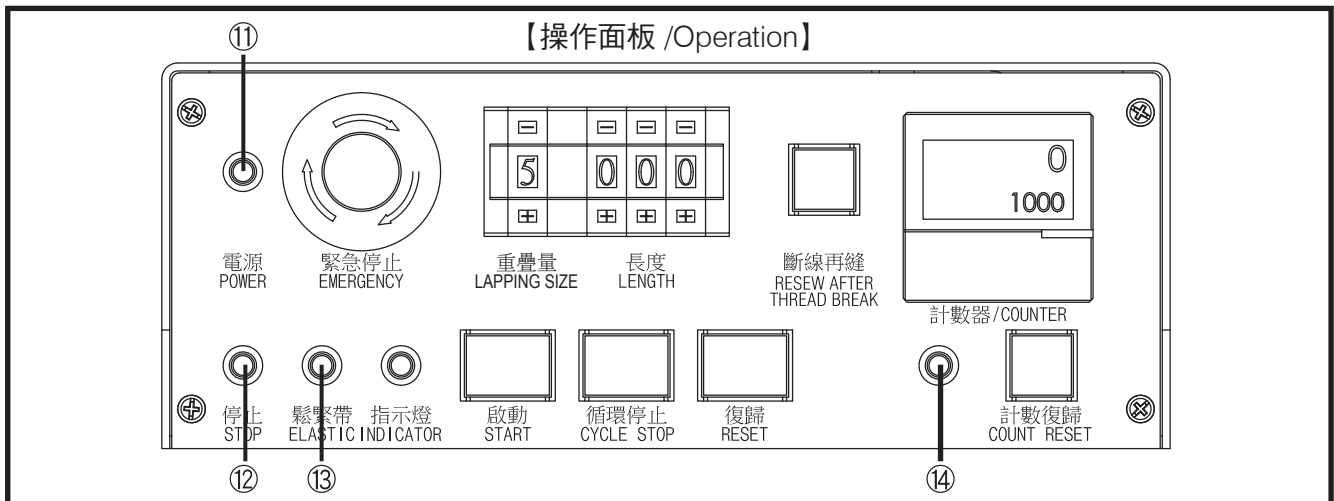

名稱 Names	功能 Functions
⑪ 「電源」燈(綠) 「POWER」Lamp (green)	<ol style="list-style-type: none"> 1. 電源開關ON的時候亮燈。 2. 機器單獨運轉的模式 (P.19)。 3. 啟動「縫製一個帶圈的連續動作」。 <ol style="list-style-type: none"> 1. Light up as power switch ON. 2. Machine operate isolated mode. (P.19)。 3. Start one shot operation for an elastic ring.
⑫ 「停止」燈(紅) 「STOP」Lamp (red)	<ol style="list-style-type: none"> 1. 當按下「緊急停止」開關的時候亮燈。(P.15) 2. 啟動「縫製一個帶圈的連續動作」。 3. 機器在不可能運轉的狀況下，按下啟動鍵時，將與「斷線」燈同時閃燈。(P.19) 4. 裝置裡的極限開關異常時，將與「鬆緊帶」燈同時閃燈。(P.19) <ol style="list-style-type: none"> 1. Light up as press 「EMERGENCY」 switch. (P.15) 2. Start one shot operation for an elastic ring. 3. As machine start signal begin, with 「THREAD」 light flashing simultaneously under the condition that machine cannot be operating. (P.19) 4. If the limit switch in the device abnormal, 「ELASTIC」 lamp would flash at the same time. (P.19)
⑬ 「鬆緊帶」燈(黃) 「ELASTIC」Lamp(yellow)	<ol style="list-style-type: none"> 1. 沒有鬆緊帶的時候亮燈。(P.19) 2. 檢測出鬆緊帶的接縫時亮燈。(P.19) 3. 鬆緊帶的延伸異常時亮燈。(P.19) <ol style="list-style-type: none"> 1. Light up without elastic tape. (P.19) 2. Light up when detecting elastic tape seam.(P.19) 3. Light up when elastic tape's feeding abnormal.(P.19)
⑭ 計數燈 Count up lamp	<p>製品設定數量完成時亮燈。(P.19)</p> <p>Light up as finish the setting amount of production. (P.19)</p>

註記：(1)⑪⑫⑬⑭ 燈的詳盡內容以及解除方式請參照表中所指示之頁數。

(2)縫紉機的獨立運轉，以及縫製一個帶圈的連續動作方式請參照表中所示之頁數。

Note : (1)The detailed contents of lamps ⑪⑫⑬⑭ and cancelation please refer to the indicated pages in the form.

(2)Please refer to the indicated pages in the form when the sewing machine operates isolated and sewing one shot operation method.

3. 縫紉機操作面板
 操作方法以及 LED 指示燈的說明請參照縫紉機使用說明書。

3. Operation panel of sewing machine
 Please refer to the instructions of operating method and illustration of LED indicator lamp.

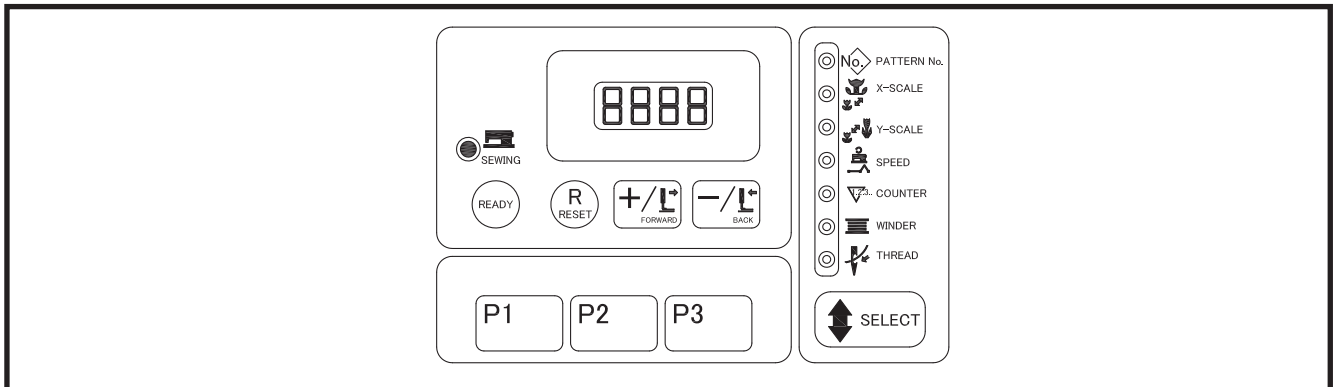

機器啟動準備

PREPARATION OF OPERATING MACHINE

1. 確認裝置高度
 在尚未送電和送氣的狀態下，將夾住鬆緊帶的夾具往下壓避免撞到其它部件①，再將送料盤②往縫紉機位置推，盤上有紅線的面③和縫紉機針板④為同一高度。當③比④低的時候 (0.3 mm以內皆可)，或③比④高 0.5 mm 以上的時候，將螺絲⑤鬆開 (從圖片中的相反側開始)，旋轉高度調整螺絲⑥以微調整高度。

1. Check the height of the device.
 Under the circumstance which do not turn the power on and let the air in. Press the clamp which clip the elastic tape down to avoid bumping into other device①. Then push the feeding plate ② to the position of sewing machine. The plate ③ surface which has red line, and sewing machine needle plate④ are the same height. When③ is lower than ④, (within 0.3 mm) or ③ is higher than ④ (more than 0.5 mm), loosen screw ⑤ (start with the opposite side of the picture). Rotate the height, adjust screw⑥ to fine adjust the height.

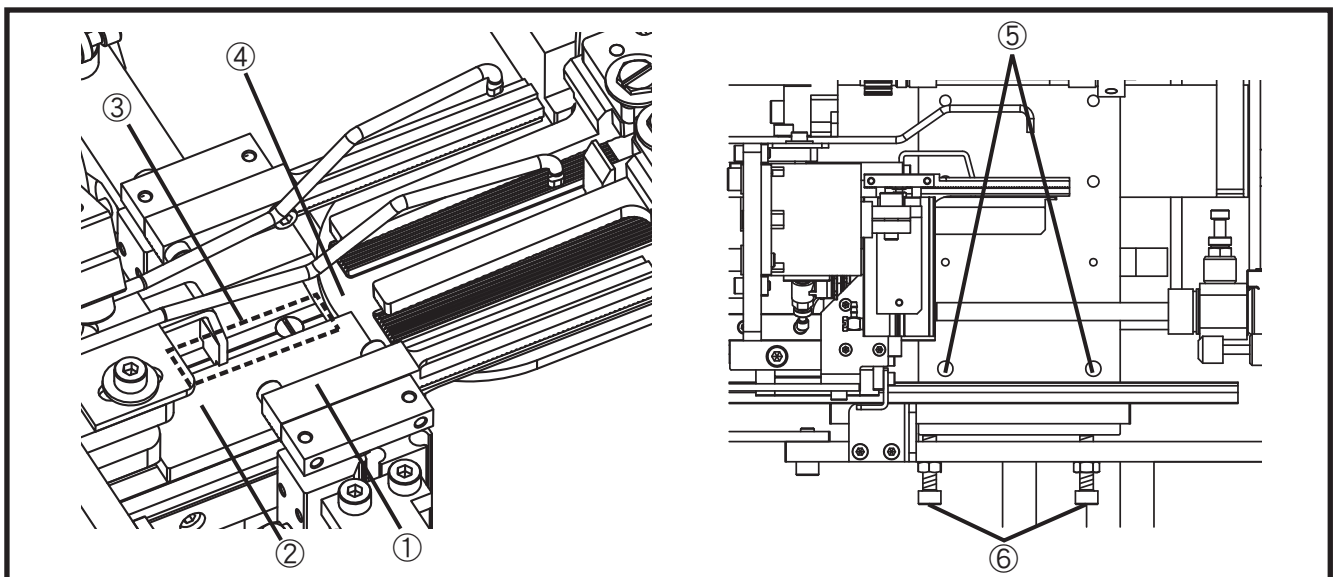

2. 氣壓

將氣壓過濾調節器設定在 0.5MPa (黑色指針)。

3. 電源電壓

以額定電壓的 ±10% 使用。地線必需接地。

4. 加油

(1) 關於機器的加油 (上油) 請參照縫紉機的使用說明書。

(2) 指標標示的裝置部分 (動刀支撐軸) 請定期補充少量機油。

2. Pneumatic pressure

Setup filter regulator to 0.5MPa (black pointer.)

3. Power source voltage

Apply rated of ±10% voltage. Earth wire have to grounding.

4. Lubrication

(1) Please refer to instructions of sewing machine for lubrication. (apply oil)

(2) Apply small drip of oil to arrow-point (moving knife device) device regularly.

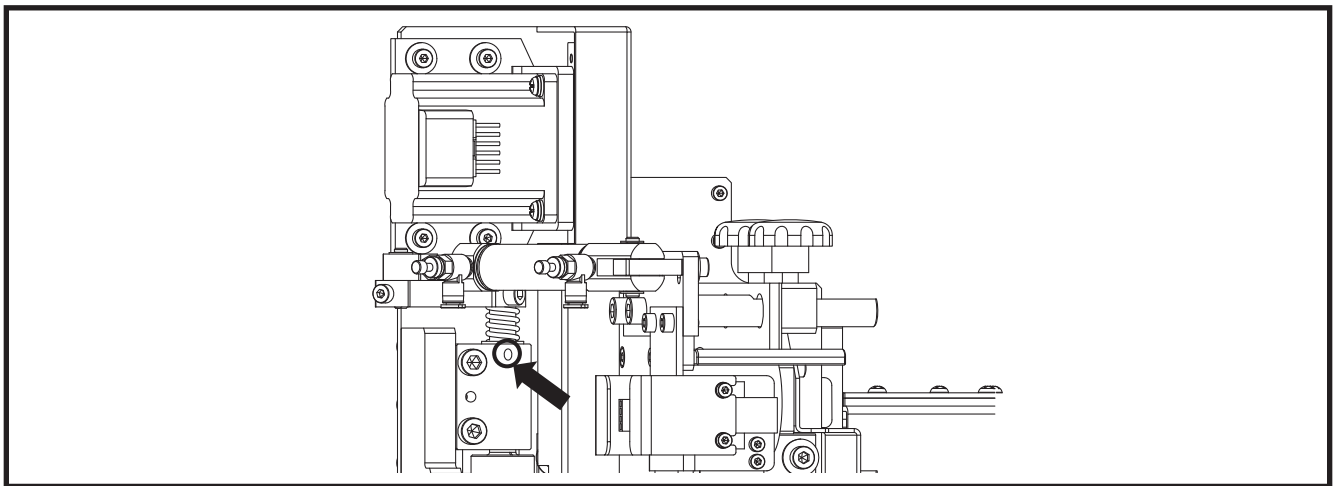

鬆緊帶的穿法

WAY TO THREAD THROUGH ELASTIC TAPE

※ 注意：長時間被扭曲皺折的鬆緊帶為不良品及問題發生的主因，請勿使用。

• 請依照圖示將鬆緊帶穿入。

※ Caution : The elastic tape which has been folding and ruffled for long time is the defective product and the main reason which may cause trouble. Please do not use it.

• Thread through the elastic tape as following picture.

A 部分：

將接縫檢測感應鋼片①及送帶滾輪部分的輔助輪②分別依指示方向打開，穿入鬆緊帶。

(※1)

B 部分：

(1) 鬆開把手③，配合鬆緊帶寬度設定送帶軌道④將鬆緊帶⑥穿入軌道。

Part A :

Open joint detecting induced plate ① and feeding roller's auxiliary roller ② to the direction of each arrow, and make through the elastic tape. (※1)

Part B :

(1) Loosen knob ③, setup feeding guide ④ to match up elastic tape's width, and let the elastic tape ⑥ through.

(2) 將送料滾輪的輔助輪⑤往箭頭方向移動，再將鬆緊帶⑥的前端約 5 ~ 10 m m (※2) 夾在送料滾輪⑦和輔助輪之間。此時，請將鬆緊帶⑥的內側貼緊軌道壁面⑧。為了正確的安裝鬆緊帶的前端位置，請打開電源開關到 ON 之後執行。(P.10)

(2) Push feeding roller's auxiliary roller ⑤ to the direction arrow pointed, then clip the elastic tape's ⑥ forefront about 5 ~ 10mm (※2) between feeding roller ⑦ and auxiliary roller. At the moment, let inner elastic tape ⑥ close to the frame ⑧. In order to install the forefront position of elastic tape, please switch ON the power switch. (P.10)

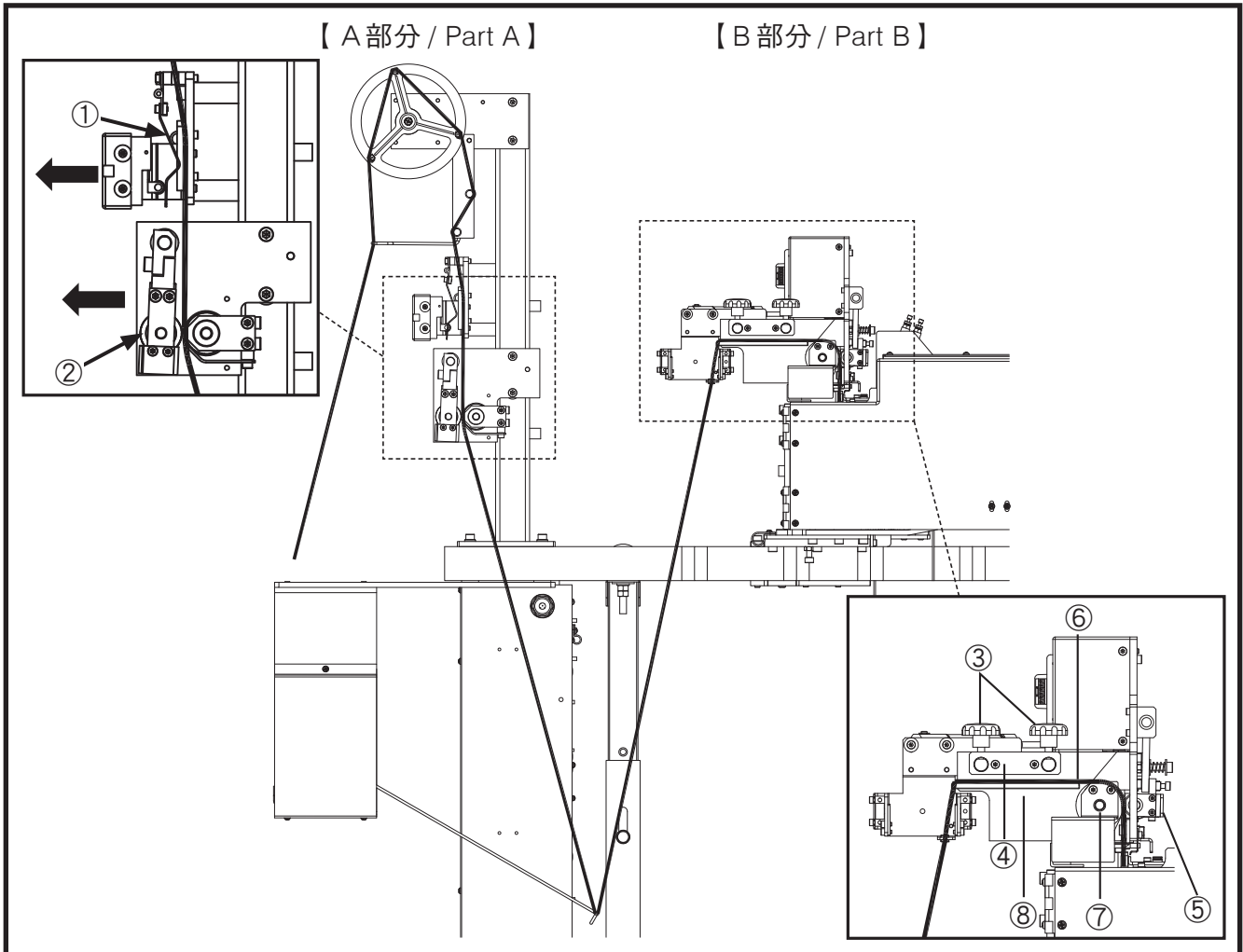

註記：

- ※1：請將鬆緊帶的接縫處如下圖般重疊搭接。
- ※2：只需夾緊鬆緊帶的前端部分即可。請勿強行塞入。

Note：

- ※1：Lap and joint the elastic tape joint part as below.
- ※2：Only need to lap forefront of elastic tape. Do not lap in force.

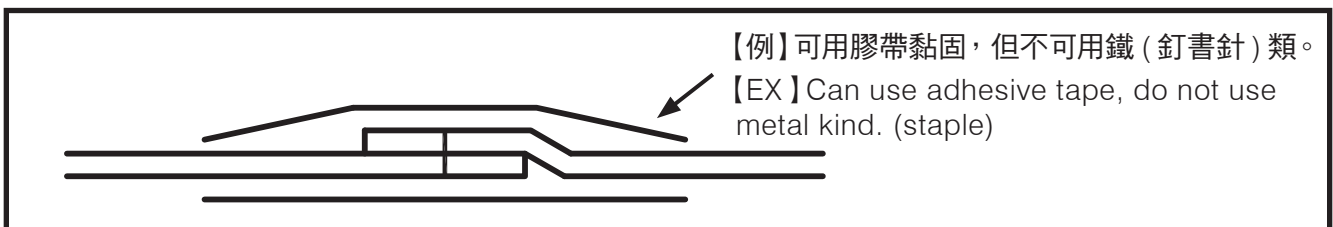

【例】可用膠帶黏固，但不可用鐵（釘書針）類。
【EX】Can use adhesive tape, do not use metal kind. (staple)

更換鬆緊帶方法

WAY TO REPLACE ELASTIC TAPE

當使用不同寬度或厚薄度的鬆緊帶時，我們必須要對機台做適當的調整，步驟如下：

1. 接縫檢測的感應鋼片的間隙需作調整：鬆緊帶通過固定板①與感應鋼片②之間，因厚薄不同，極限開關的感應距離需做調整，調整②與極限開關③的間隙。調整方法是將兩顆螺絲④放鬆一點，向左或右移動調整。(約鬆緊帶厚度的兩倍左右)。

We need to adjust the machine properly while using elastic tape with different width and thickness. Follow the steps below:

1. Joint detecting induced plate's gap need to do the adjustment: Because of difference of the thickness, while elastic tape go through between the fixed plate① and sensor steel disc②; the sensor distant of the limit switch need to do adjustment. Adjust the gap between② and limit switch③. Loosen two screw④ a little bit, and move left and right to adjust. (About double thickness of elastic tape.)

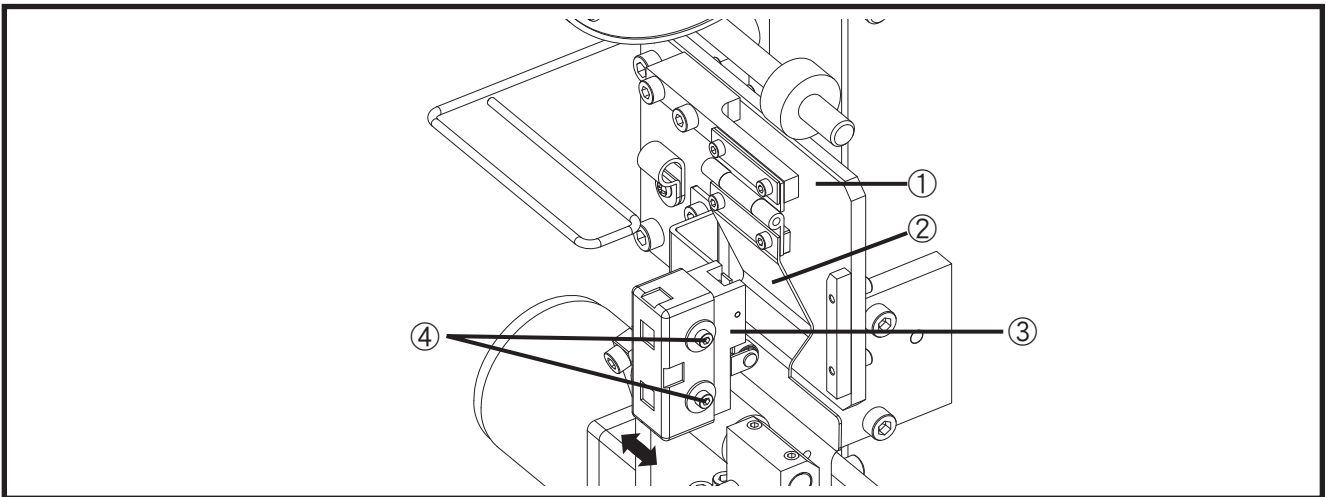

2. 調整鬆緊帶寬度：將兩個旋鈕⑦放鬆後，配合通過軌道平台⑥的鬆緊帶⑤寬度 (比鬆緊帶多 1mm)，再將旋鈕⑦轉緊即可。

2. Adjust the width of elastic tape: After loosen two knobs⑦, match up the width of elastic tape⑤ (wide 1mm than elastic tape) through the feeding guide⑥, and finally tighten the knobs⑦.

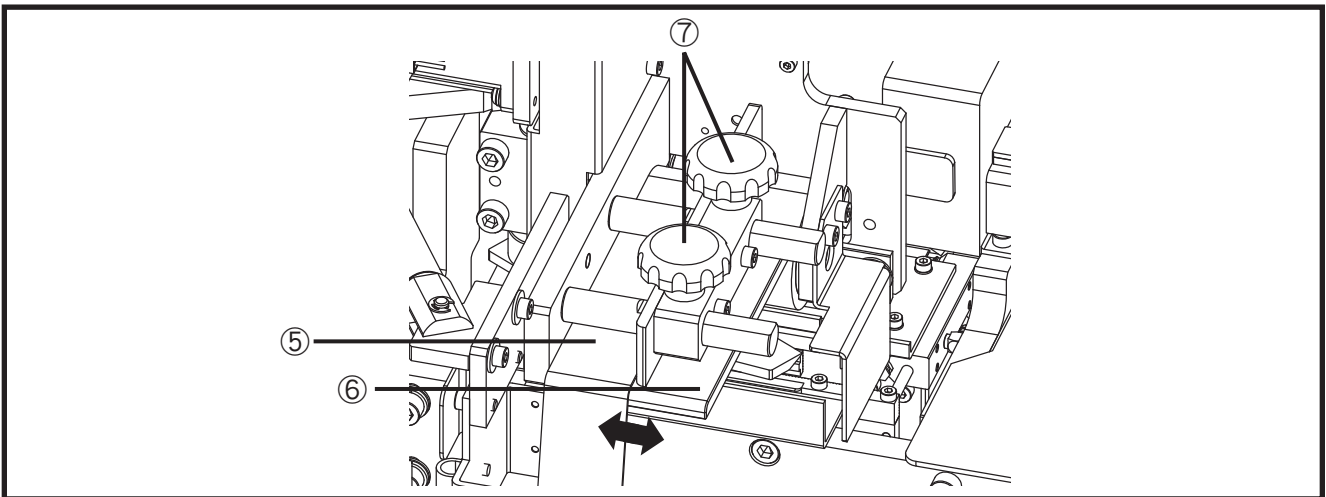

3. 調整鬆緊帶定位片：鬆緊帶⑤的邊緣需調整與頂片⑧貼平，調整的方式是將旋鈕⑨放鬆後，調整頂片⑧至鬆緊帶邊緣貼平後，再將旋鈕⑨旋緊即可。
4. 當發現鬆緊帶會捲曲時，可微調吹氣管⑩的方向或角度至鬆緊帶⑤平整為止。

3. Adjust elastic tape locating plate : The edge of the elastic tape⑤ need to close tight with stopper⑧. The way to adjust it is to loosen knob⑨, then adjust the stopper⑧ until it close tight with the edge of elastic tape, and finally tighten the knob⑨.
4. If you found that elastic tape would curl, fine adjusts the direction or angle of air blow tube⑩ until elastic tape be level.

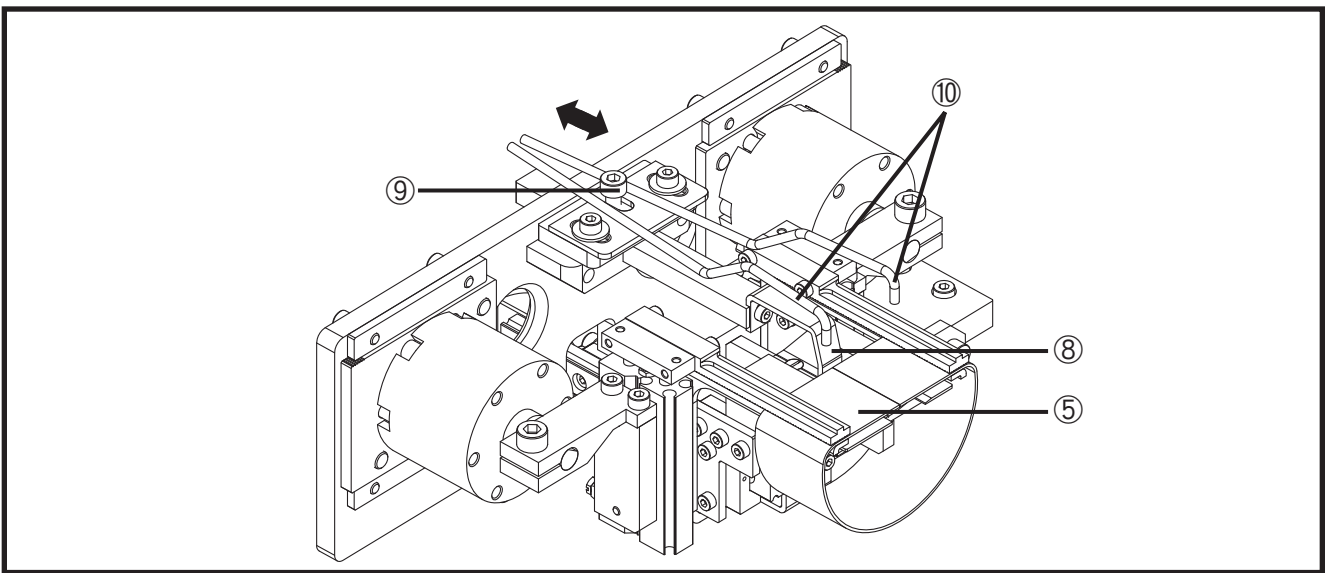

啟動

OPERATION

※ 啟動的流程操作（概要）

1. 打開電源開關 ON。(一方面讓鬆緊帶的前端自動切齊，同時讓機器進行初始化的狀態。)
2. 剛開始一定要設定縫紉樣式及製品長度等。
3. 按「啟動」開關(綠)。將鬆緊帶送入縫紉機之前，機器會暫時停止。
4. 確認鬆緊帶是否正確安裝。請依鬆緊帶的寬度、材質等狀況進行調整。
5. 如要開始縫製，再按一次「啟動」開關(綠)：開始連續縫製或者是，「循環停止」開關(黃)：僅製作一個成品後即待機。如果不進行縫製，並且要重新設定鬆緊帶的時候請按「復歸」開關(藍)。

※ Brief explanation of operation procedure.

1. Turn on the power switch. (Let forefront of elastic tape positioning automatically, and let the machine being initialization.)
2. Must setup the sewing pattern and the length of product first, etc.
3. Press the switch START(green.) Before sending elastic tape into sewing machine, the machine will stop temporary.
4. Assure elastic tape's position correctly. Adjust elastic tape according to its width, material, etc.
5. Press the switch START (green) again to start to operate: start to continuous sewing, or press the switch CYCLE STOP (yellow): sewing one product only then standby. If do not operate the machine, instead to reset elastic tape, press the switch RESET(blue.)

(1) 設定縫紉花樣圖形以及調整圖形長度

1. 打開電源開關至 ON。
 2. 按下縫紉機操作面板的 READY 按鍵①後 SEWING LED ②燈熄滅。
 3. 按 SELECT 按鍵③，使 PATTERN No. ④旁的 LED 燈亮起。
 4. 按 + /FORWARD 按鍵⑤或者是 - /BACK 按鍵⑥，面板⑦上會顯示不同的鬆緊帶長度的圖形序號。
- ※ 注意：請參照次頁的縫紉花樣圖形範例。另外舉例說明，假如鬆緊帶的寬度 (Y) 是 5mm，表中沒有相對應的鬆緊帶寬度的時候，請照下述方式使用放大、縮小機能。
5. 按 SELECT 按鍵③，使 Y-SCALE ⑧旁的 LED 燈亮起，再按下 + /FORWARD 按鍵⑤或按住 - /BACK 按鍵⑥即可調整 Y 的放大縮小比例（百分比）。且最後的數值仍需以實際縫製的成品來決定。
 6. 按 READY 按鍵①後 SEWING LED ②會亮燈。

(1) Setup sewing pattern and sewing length adjustment.

1. Turn on the power switch.
 2. Press READY ① on sewing machine's operation panel, then light off SEWING LED ②.
 3. Press SELECT ③ to light up LED lamp beside PATTERN No. ④.
 4. Press + /FORWARD ⑤ or - /BACK, the panel ⑦ will show different pattern NO. of elastic tape length.
- ※ Caution: Please refer to example of sewing pattern from next page. Besides, for example, if the width (Y) of elastic tape is 5mm, however, the form do not have the corresponding width of elastic tape, please follow the expand and reduce function below.
5. Press SELECT ③ switch, to light up the LED lamp beside Y-SCALE ⑧, then press + /FORWARD ⑤ or - /BACK ⑥, which can adjust the expand and reduce ratio (percentage) of Y. The final figure will still depends on the actual sewing product.
 6. After pressed READY ① the SEWING LED ② will light up.

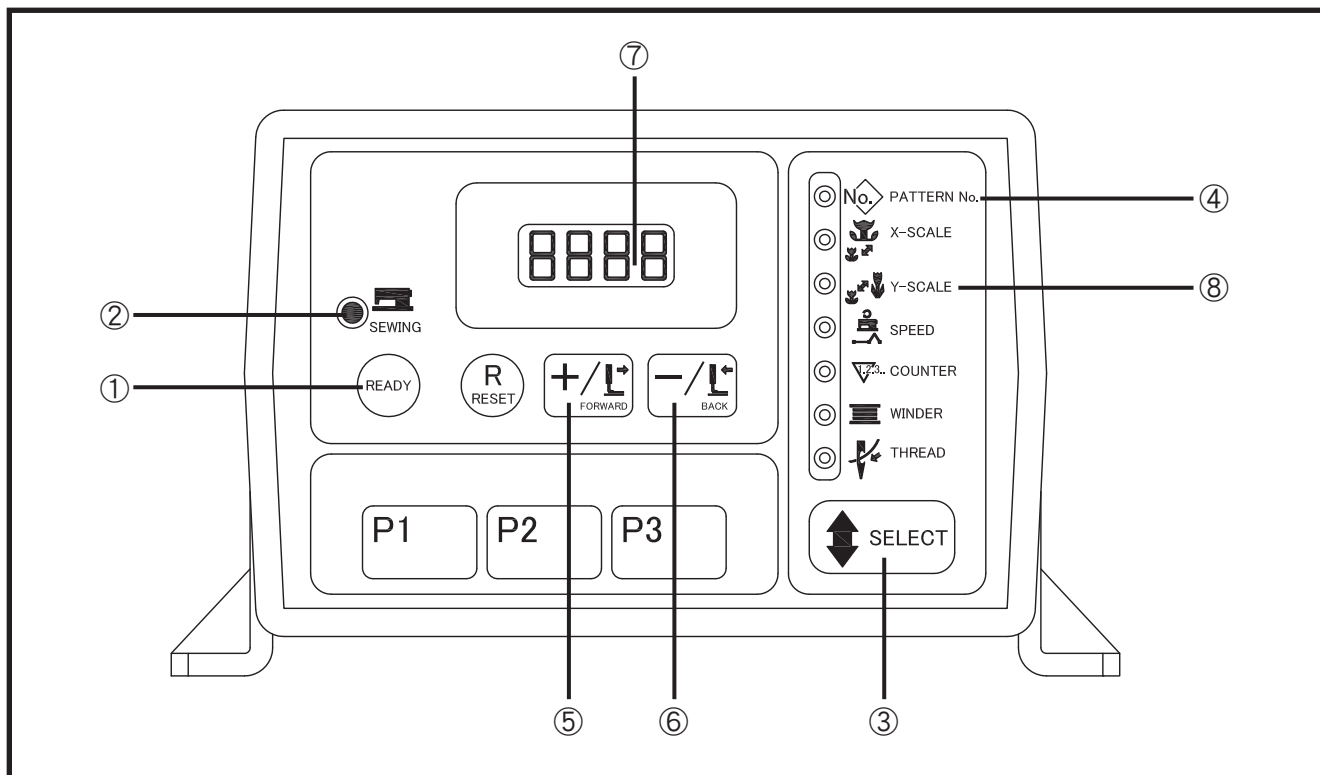

•縫製花樣圖形列表

•Sewing Pattern List

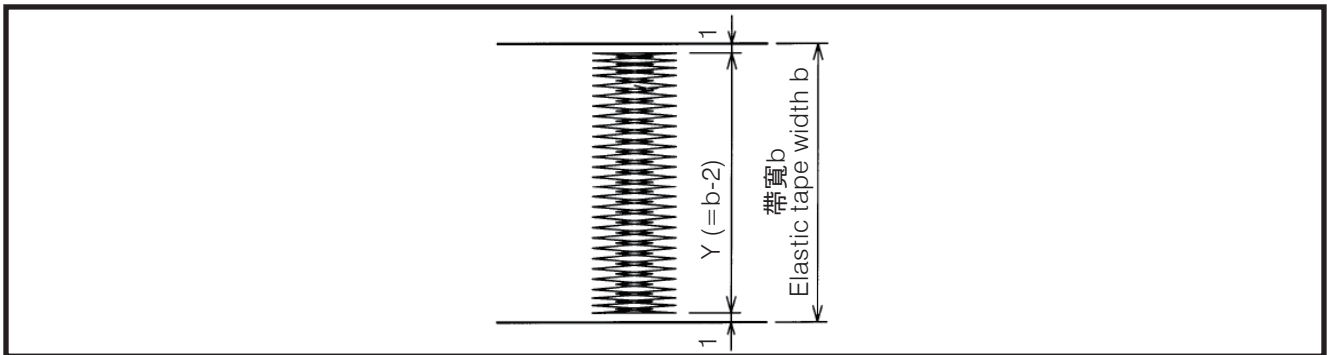

編號 No.	花樣類型 Stitch diagram	針數 Number of stitches	圖形尺寸 Sewing size	
			橫向寬度 Cross width	縱向寬度 Length width
1		15	6	0
2		19	10	
3		27	15	
4		33	20	
5		39	25	
6		45	30	
7		51	35	
8		57	40	
9		63	45	
10		69	50	
11		75	55	
12		20	6	3
13		24	10	
14		32	15	
15		38	20	
16		46	25	
17		52	30	
18		60	35	
19		66	40	
20		72	45	
21		80	50	
22		86	55	
23		25	6	5.2
24		37	10	
25		43	15	
26		57	20	
27		69	25	
28		77	30	
29		88	35	
30		96	40	
31		109	45	
32		113	50	
33		125	55	

編號 No.	花樣類型 Stitch diagram	針數 Number of stitches	圖形尺寸 Sewing size	
			橫向寬度 Cross width	縱向寬度 Length width
34		35	6	6.4
35		47	10	
36		59	15	
37		71	20	
38		87	25	
39		98	30	
40		111	35	
41		127	40	
42		139	45	
43		151	50	
44		163	55	
45		60	6	9
46		92	10	
47		130	15	
48		172	20	
49		212	25	
50		252	30	
51		284	35	
52		324	40	
53		356	45	
54		396	50	
55		428	55	
56		32	6	10
57		37	10	
58		46	15	
59		54	20	
60		60	25	
61		69	30	
62		78	35	
63		86	40	
64		93	45	
65		102	50	
66		111	55	

•放大縮小比例的設定範例

34mm 寬的鬆緊帶，使用與上圖相同的縫製花樣時：

- (1) 圖形序號 No.：設定為 No.35。
- (2) 放大縮小比例：把 Y-SCALE 設定為 96 ~ 97% (請依實際縫製的結果決定數值)。

•Setup example of expand/reduce ratio

If 34mm wide of elastic tape was using the same sewing pattern above：

- (1)Pattern No.：No.35 setup.
- (2)Expand/Reduce ratio：Setup 96~97% Y-SCALE (Please decide the ratio from sewing results.)

(2) 設定及調整鬆緊帶長度

1. 用「長度」設定開關① (單位：mm) 設定如左下圖所示之完成長度「L」。設定值的有效範圍為150~999。設定150以下的數值仍為150。(注意)帶圈的全長為(2×L) mm。
2. 「長度」設定開關①所顯示之設定值為標準值，請依帶圈的長度適度增減設定值。
【注意】如果鬆緊帶的材質有差異，即使是相同的L設定值，實際的帶圈長度也會有差異。(因鬆緊帶材質軟硬變異多，因此設定的長度需要依實際作調整，如軟材質應微幅加長其長度)

(2) Elastic length setup and adjustment

1. Setup finish length 「L」 as below, with length setup switch①(mm). The validity range of default is 150~999. If the ratio is lower than 150, same as 150 setup ratio. (Attention) The whole length of elastic ring is (2×L) mm.
2. The ratio of setup LENGTH switch① is standard ratio, please according to elastic ring's length to increase or reduce the ratio properly.
【Attention】 If the material of the elastic tape has differences, the actual length of elastic ring will be different, even with the same L ratio. (Because there are lots of varieties of elastic tape's material (hardness/softness,) hence the setup length need to be adjust according to the material. For example, soft material should fine add its length.)

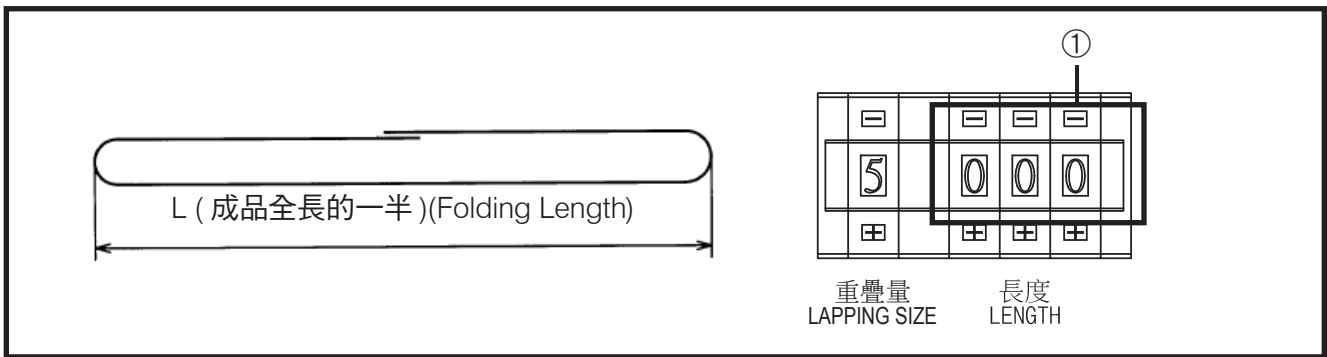

(3) 重疊量設定值

調整帶圈的重疊範圍。數字越大其重疊搭接越多。請將初期的標準值設為「5」。

(3) LAPPING SIZE setup ratio

Adjust the lap range of elastic ring. The larger of the number, the more laps of elastic ring. Please setup the initial standard ratio to be 「5」.

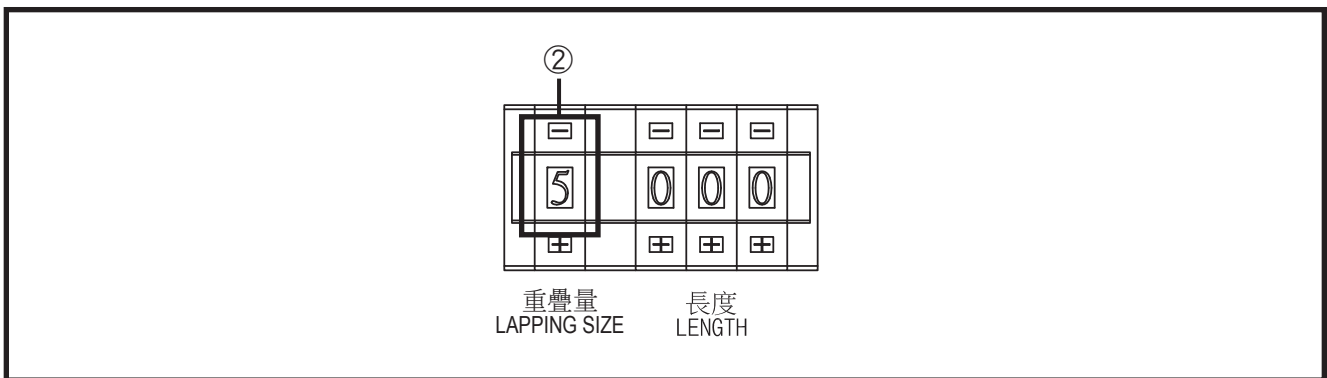

(4) 鬆緊帶前端的設定

1. 打開電源開關 ON 時自動執行。
2. 從送料滾輪將新帶子送入的時候，為使第一個帶圈的長度正確，請參照下列操作方法：長按「復歸」開關③。（按 1 秒以上）可確保鬆緊帶送入的前段位置是正確的。此時被切斷的數公分鬆緊帶將被捨棄。

(4) Position forefront of elastic tape

1. Switch on the power and position automatically.
2. In order to let the first elastic ring's length correctly, after feeding roller send the new elastic tape in, please follow the operation below: Press the RESET switch③ more than one seconds. It can insure the forefront of elastic ring position correctly. At the time, the centermeters of elastic tape which been cut off would be abandoned.

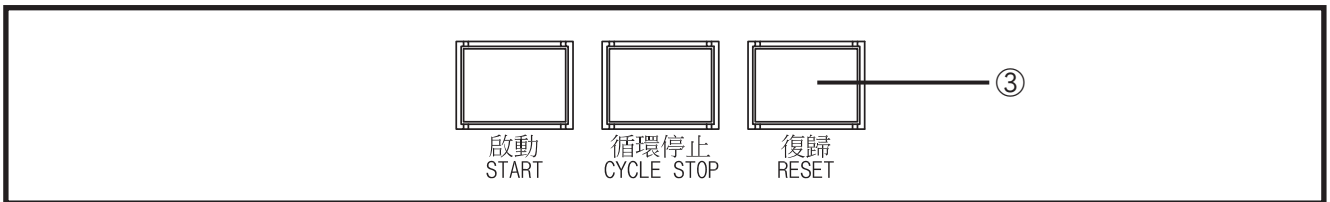

(5) 啟動機器

1. 按「啟動」開關④。機器會拉出一段鬆緊帶形成帶圈並準備送入縫製，此時機器會暫時停止。
2. 請確認製品的接合或是重疊部分符合設定。如果設定有問題請參照前述的處理方法。
3. 只有第一次需要將螺絲⑤鬆開後，將帶子前端導引器⑥與帶邊貼平。
4. 之後選擇以下的操作。
 - a. 連續運轉。→ (6) 的操作
 - b. 只完成一個製品。→ (7) 的操作
 - c. 重新。→ (8) 的操作

(5) Starting

1. Press START switch④, the machine will pull a length of elastic tape which becomes elastic ring, and start to send into sewing. The machine would stop temporary at the time.
2. Please make sure the seam or lap part of the product fit the setting. If the setting has any problems, please refer to the resolution before.
3. Only the first time need to loosen screw⑤, after, fit in tape edge front guide⑥ to tape width.
4. Then, follow the operation below:
 - a. Continuous operation. → operation (6)
 - b. Sewing one piece only. → operation (7)
 - c. Reposition elastic tape. → operation (8)

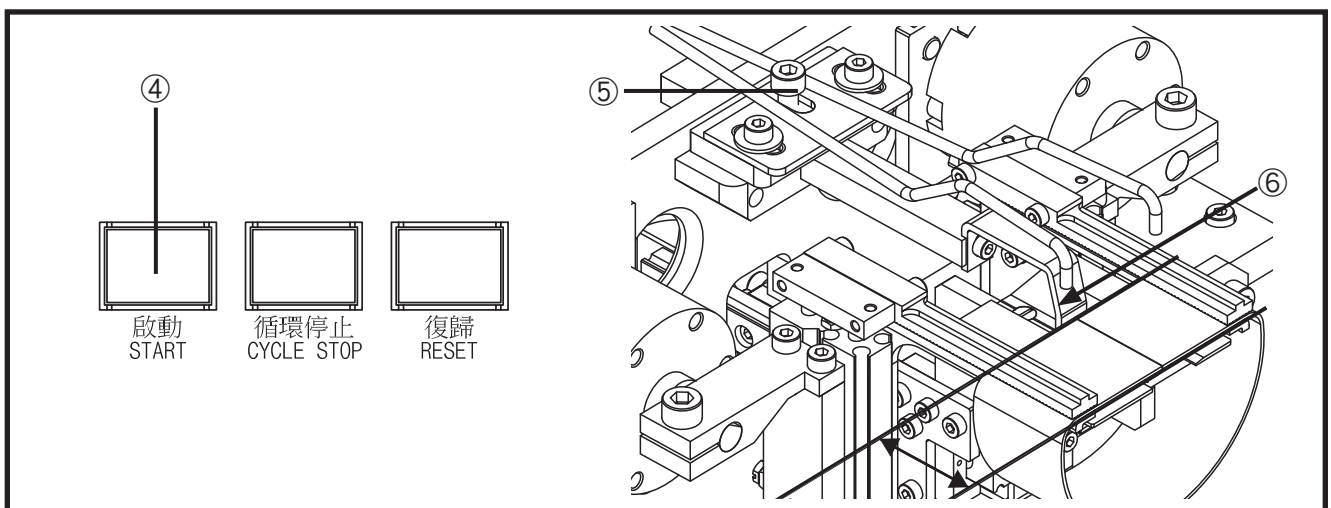

(6) 連續運轉

- 確認完成 (5) 的操作後：
 1. 按「啟動」開關④。→連續運轉。
 2. 按「循環停止」開關⑤的時候停止。→最後的製品完成後即停止。
 3. 想要立刻停止機器時，請按「緊急停止」開關⑥。→機器停止時，STOP 燈⑦會亮燈。

※ 關於之後的操作方法請參照「指示燈的表示及解除」。

(6) Continuous operation

- After make sure finish operation (5) :
 1. Press START switch④ →Continuous operation.
 2. Press CYCLE STOP switch⑤ for stop→Stop after finish the final product.
 3. Press the EMERGENCY switch⑥to stop the machine immediately. →STOP lamp⑦ will light up when machine stop.

※About the operation later, please refer to 「The representation of indicator lamp & cancelation」.

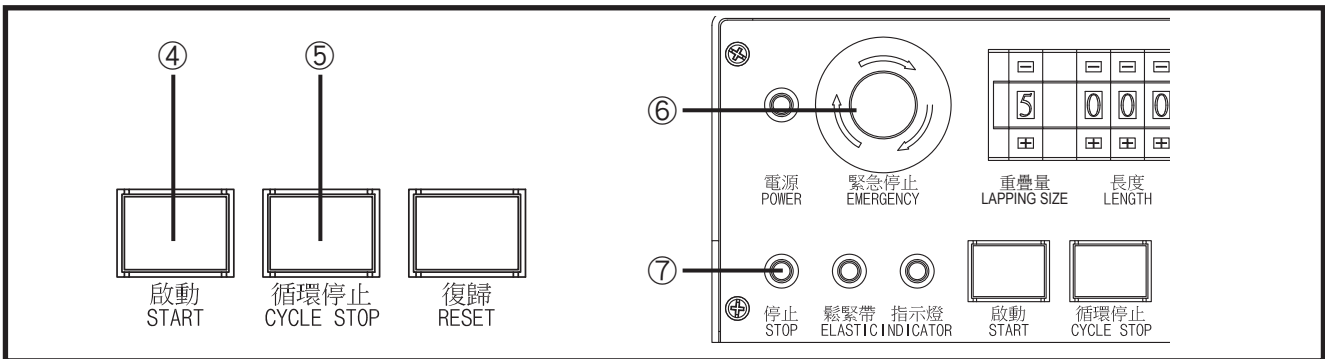

(7) 僅製作一個成品

- 確認完成前頁 (5) 的操作後：

按「循環停止」開關⑤。完成一個成品的製作後即停止。

(7) Sewing one piece only

- Make sure finish the operation(5) above:

Press CYCLE STOP switch⑤. Stop after finish one piece only.

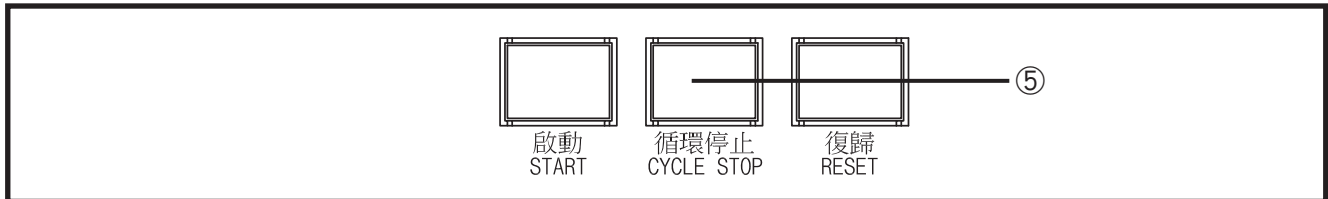

(8) 重新安裝鬆緊帶

- 確認完成前頁 (5) 的操作後：
 1. 按「復歸」開關③。卸除已預備車縫的鬆緊帶。此時可調整鬆緊帶尺寸與重疊範圍。
 2. 按「啟動」開關④。機器會依新的設定拉出鬆緊帶，形成帶圈後會再次暫時停止準備送入車縫。

(8) Reposition elastic tape

- Make sure finish the operation(5) above:
 1. Press RESET switch③. Put off the elastic tape which been ready. At the time, you could adjust elastic tape size and lap range.
 2. Press START switch④. The machine will depends the new setting to pull out elastic tape. After became elastic ring, the machine will stop again temporary and be ready to sew.

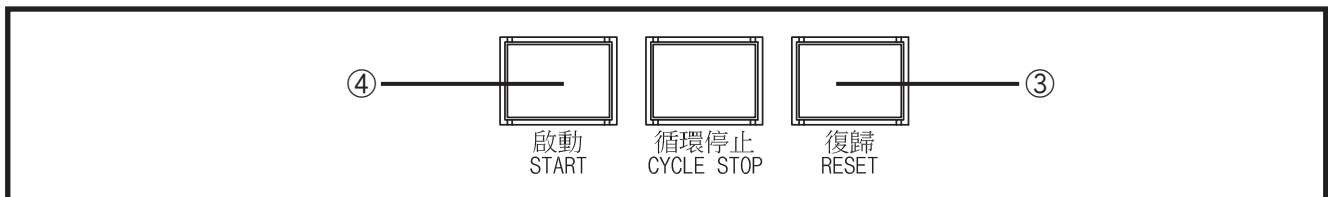

調整接合位置及重疊範圍

ADJUST BUTTED SEAM & LAPPING SEAM

(1) 接合部分的調整

1. 鬆開螺絲①，調整左邊供帶氣缸的固定座②上的紅色刻線與箭頭③的位置對齊。
2. 鬆開螺絲④，調整右邊供帶氣缸的固定座⑤上的紅色刻線與箭頭⑥的位置對齊。

(1) Adjust butted seam

1. Loosen screw①, adjust and align right end scribing red line of left hand tape supplier cylinder fixed seat ② with arrow③ position.
2. Loosen screw④, adjust and align right end scribing red line of left hand tape supplier cylinder fixed seat ⑤ with arrow⑥ position.

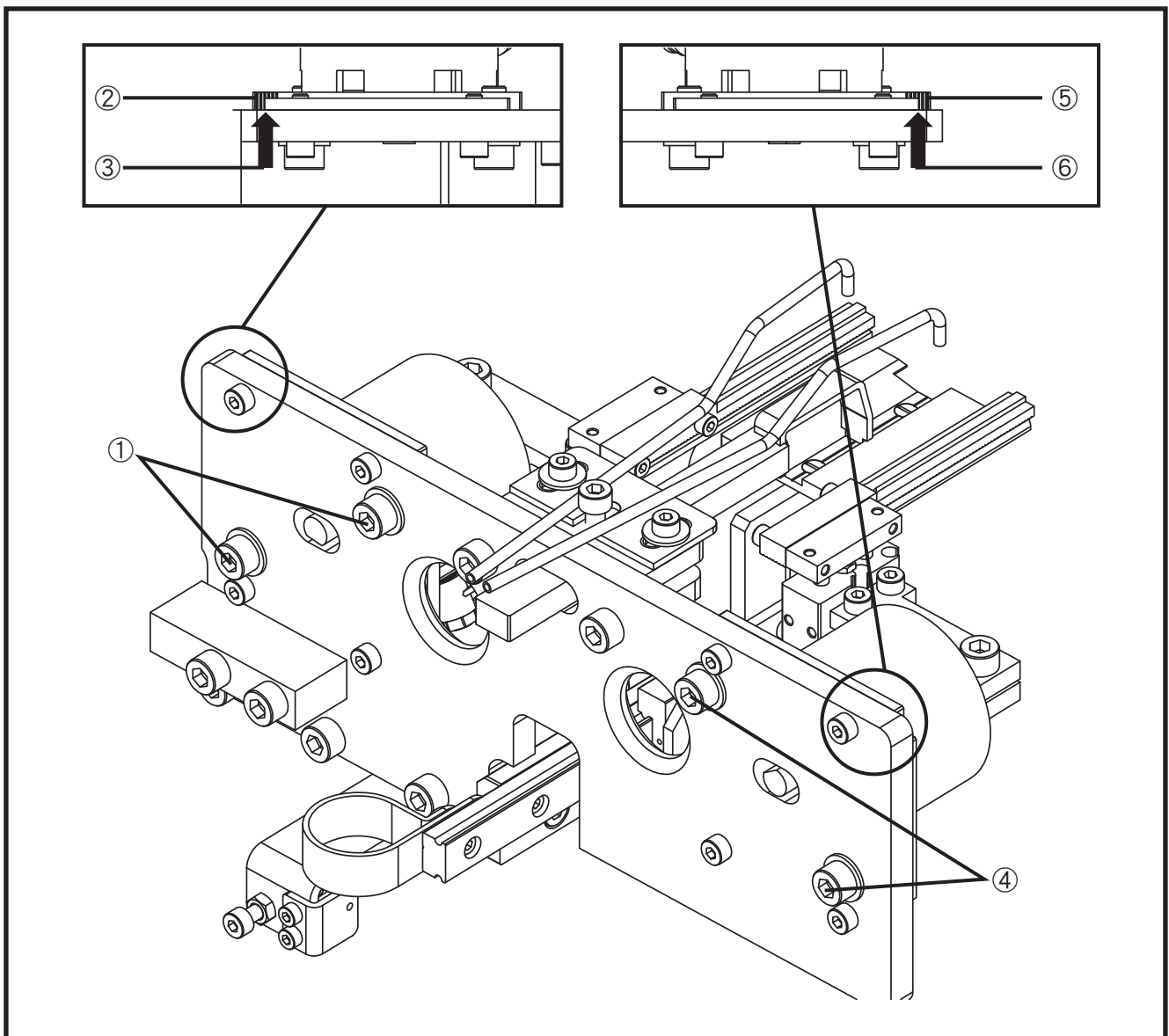

3. 打開電源開關至 ON，按「啟動」開關。
4. 在帶圈車縫的暫停狀況下（下圖），鬆緊帶的左端⑦和右端⑧與送料板⑨的紅線⑩的位置對齊即可。

•調整方式

1. 左端⑦的位置在出貨時已調整完畢。※1
2. 右端⑧的位置不合的時候，變更「重疊量」欄內顯示數值⑪（標準：5）即可調整。※2
3. 接合位置⑫如果有空隙的時候→⑪的數值要變大。
4. 超過紅線⑩左端⑦的上方重疊的時候→⑪的數值要變小。

【註記】

- ※1：如須再調整的時候請依上述（1）微調左邊供帶氣缸動固定座②的位置。
- ※2：數值每增加 1 時，右端⑧的位置約向左移動 0.6 mm。通常即使更換鬆緊帶，材質如沒有太大的改變時，使用原本設定的數值即可。

3. Press power switch ON, press START switch.
4. Under the circumstances that elastic ring sewing stop (picture below,) elastic tape left end⑦, right end⑧, and feeding plate ⑨ are aligned red line ⑩.

•Adjustment

1. Left end⑦ position was finished adjustment before shipment. ※1
2. If right end⑧ position could not align, fine adjust (LAPPING SIZE) ⑪ rate (standard 5). ※2
3. If the butted joint part ⑫ has interval → increase ⑪ rate.
4. Over the red line⑩ and lapped on the top of left end⑦ → decrease ⑪ rate.

【Note】

- ※1：If needed readjust, please refer to (1) above. Fine adjust left side tape supplier cylinder fixed seat ② position.
- ※2：Every time increase 1 rate, position right end⑧ moving left about 0.6mm. Usually, if the materials of elastic tape are similar, use the original rate when changing elastic tape.

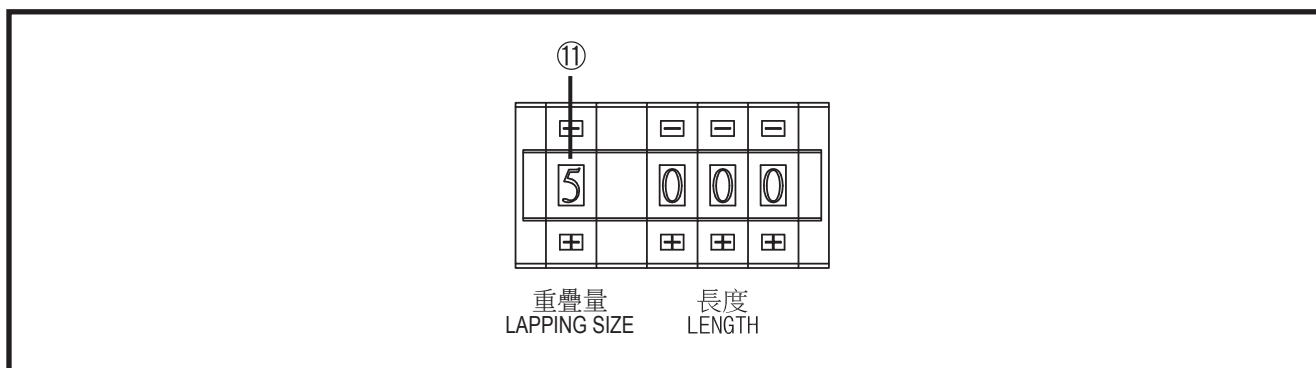
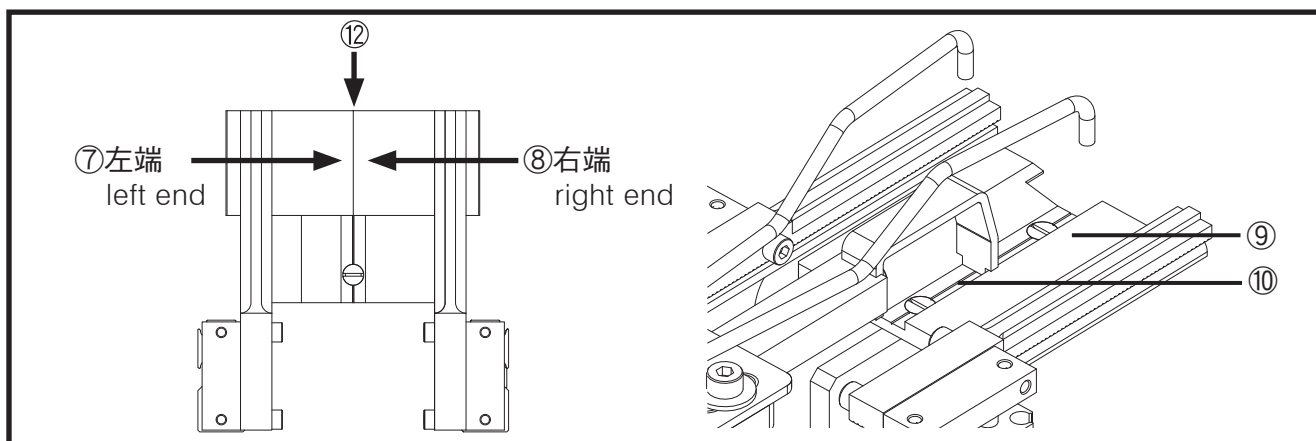

(2) 調整重疊範圍

1. 以接合位置設定紅色刻線的位置（調整為下方圖片的標準位置），左右對齊的刻線要相同（※）將左邊調整板②往箭頭⑬的方向移動，右邊調整板⑤往箭頭⑭的方向移動。
2. 放鬆螺絲①以調整左邊供帶氣缸的固定座②，放鬆螺絲④以調整右邊供帶氣缸的固定座⑤。

【註記】

※ 如左右對齊的刻線不同，帶圈的重疊中心會改變。將左右的紅刻線分別移動一刻度的話，重疊的範圍會改變 2 ~ 3 mm。

(2) Adjust lapping seam

1. Use lapping seam position to setup scribing red line position. (Adjust standard position picture below.) For scribing line, move each direction equally, (※) left hand adjustment plate ② to direction arrow ⑬, right hand tape supplier cylinder fixed seat ⑤ to arrow ⑭.
2. Loosen screw ① to adjust left hand tape supplier cylinder fixed seat ②, loosen screw ④ to adjust right hand tape supplier cylinder fixed seat ⑤.

【 Note 】

※ If each direction scribing line unequal, the lapping center of elastic ring will be different. Move each red scribing line right and left one scale, the lapping size will become 2~3mm.

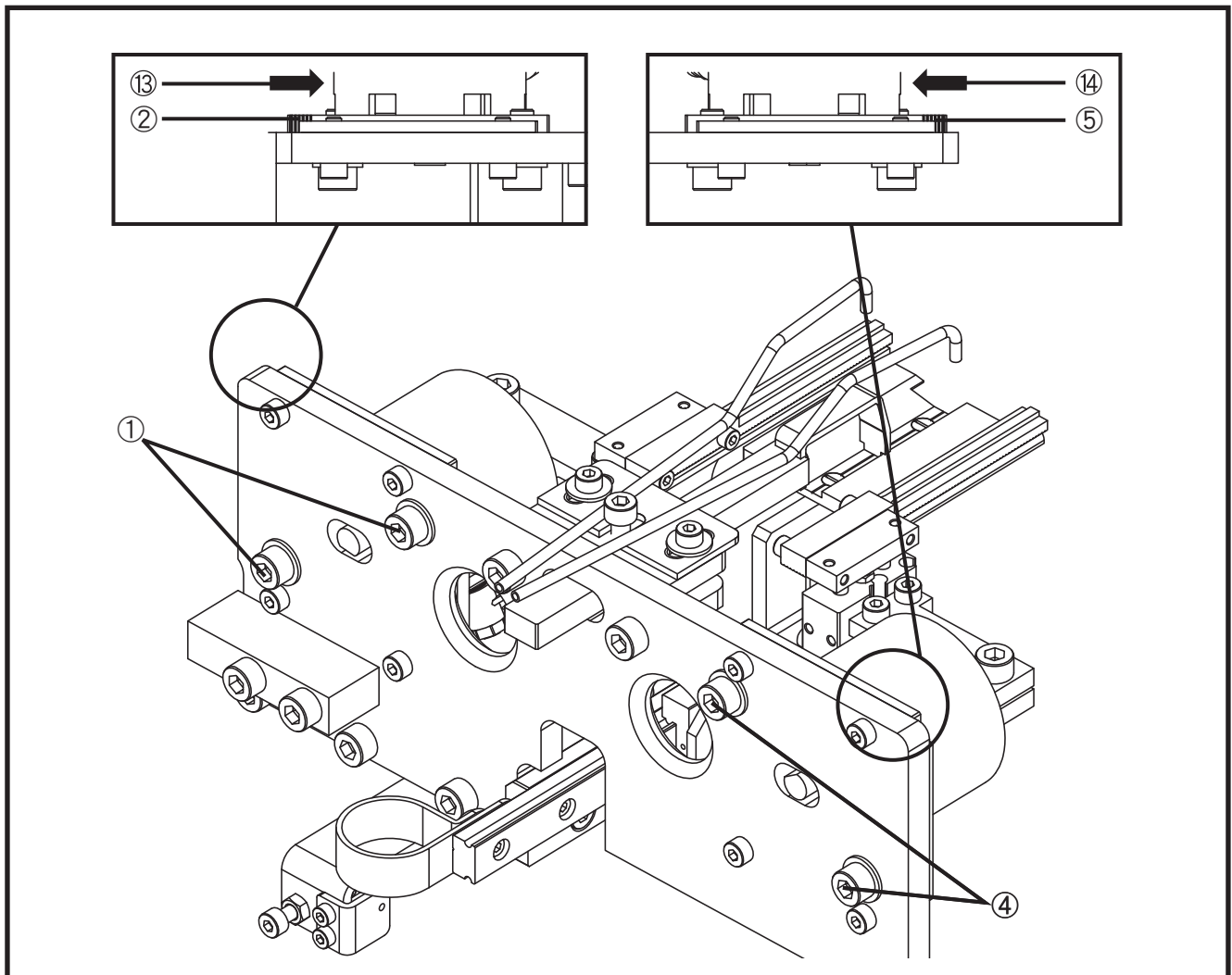

指示燈的表示及解除

THE REPRESENTATION OF INDICATOR LAMP & CANCELATION

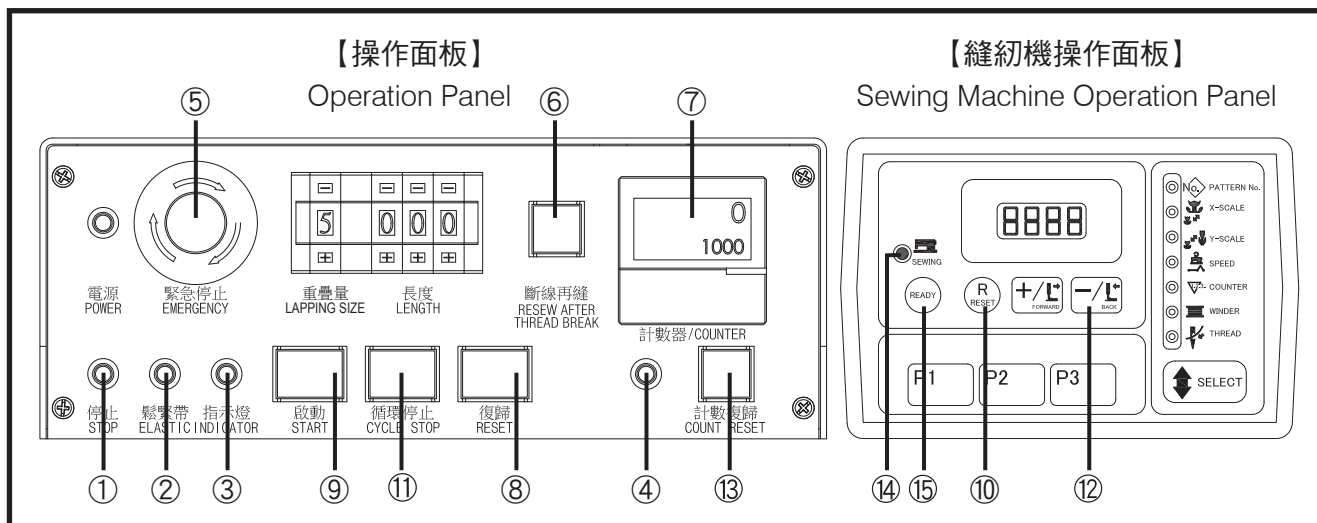

指示燈 Indicator Lamp	狀態 Condition	內容 Explanation of Indicator	解除方法 Cancelation
「停止」燈① STOP lamp ①	亮燈 Lighting-up	按了「緊急停止」開關⑤。 Press EMERGENCY switch ⑤ .	A1
「鬆緊帶」燈② Elastic tape(ELASTIC) lamp ②	亮燈 Lighting-up	1. 鬆緊帶用盡。 2. 檢測出鬆緊帶有接縫。 1. Finish up elastic tape. 2. Detected elastic tape joint.	A2 A3
	閃燈 Flashing	1. 鬆緊帶的供應裝置異常。 2. 供應設備 1. 以外的問題。如鬆緊帶脫落等。 1. Elastic tape's feeding device abnormal. 2. Except feeding device 1's problem, likev fall off elastic tape, etc.	A4 A5
累計燈④ Count up lamp ④	亮燈 Lighting-up	「計數器」⑦累計至設定數量。 COUNTER ⑦ count up to setting amount.	A6
「停止」燈① 與「指示燈」③ STOP lamp ① &INDICATOR lamp ③	同時閃燈 Flashing at once	縫紉機非待機狀態。(操作縫紉機操作面板的 READY ⑮按鍵未按下。) Sewing machine isn't standby position. (Do not press READY ⑮ on sewing machine operation panel.)	A7
「停止」燈① 與「鬆緊帶」燈② STOP lamp ① &Elastic tape(ELASTIC)lamp ②	同時閃燈 Flashing at once	設備內的極限開關 (LS) 感應器有異常狀況。 Limit switch detector in the device has abnormal condition.	A8

•解除方法

A 1 ·解除「緊急停止」開關

- (1) 將「緊急停止」開關⑤依按鈕上的箭頭方向轉動即可解除。
- (2) 按「復歸」開關⑧→停止燈①不亮燈。
- (3) 按「啟動」開關⑨→重新啟動(※1)就算機器被中斷時也可以繼續縫製。

【註記】※1

按下「緊急停止」開關⑤時候，機器是停止在下列的 a 或是 b 的狀態。之後照平常的操作即可繼續運轉。

- a. 打開電源開關至 ON 之後停止在待機位置。
- b. 帶圈準備送入縫製前若在機器運轉中，按下「緊急停止」開關⑤。縫製會中斷(依上記(2)操作)，縫紉機操作面板顯示 E5，依照下面的(4)、(5)操作：
- (4) 按 R(RESET) 鍵⑩→執行切線。
- (5) 再按 R(RESET) 鍵⑩→排除不良品接著與上記(3)的※1相同。

A 2 ·補充鬆緊帶(鬆緊帶用盡)

- (1) 將剩餘的鬆緊帶抽出。
(請注意！先按「復歸」開關⑧的話鬆緊帶會變得難以抽出)
- (2) 按「復歸」開關⑧。→設備回復待機(原點)。
- (3) 安裝新的鬆緊帶。→「鬆緊帶」燈②不亮。
- (4) 長按「復歸」開關⑧讓機器自動偵測並設定鬆緊帶的起點。
- (5) 按「啟動」開關⑨。→重新啟動。

•Cancellation

A 1 . Cancel EMERGENCY switch

- (1) Cancel EMERGENCY switch ⑤to direction of the arrow.
- (2) Press RESET switch⑧ → Light off stop lamp①.
- (3) Press START switch⑨ → Restart (※1). Could continuous sewing even the machine has suspended.

【 Note 】※1

Machine will stop in a. or b. condition below, after press EMERGENCY switch⑤. Then follow the usual operation, it could continue operate.

- a. Turn on power switch and stop on standby position.
- b. Before sew elastic ring. If press EMERGENCY switch⑤ while machine operating, the sewing would stop. (operate and follow (2) above.) Sewing machine operation show E5, operate and follow the method (4),(5)below :
- (4) Press R(RESET)⑩→ Operation thread trimming work.
- (5) Press R(RESET)⑩ again→ Eliminate reject product, then as same as above (3)※1.

A 2 . Resupply elastic tape (Finish up elastic tape)

- (1) Take off the remaining elastic tape.
(Attention! The elastic tape would be hard to take off if press RESET switch⑧first.)
- (2) Press RESET switch⑧ → Device get back to standby position (Original point)
- (3) Position new elastic tape.→ Light of elastic tape (ELASTIC) lamp②.
- (4) Press RESET switch⑧ for over seconds to let machine detects automatically and setup starting point of elastic tape.
- (5) Press START switch⑨ → Restart operation.

A 3 · 排除鬆緊帶的接縫處

- (1) 鬆緊帶的接縫處以剪刀剪除。
- (2) 按「復歸」開關⑧。→「鬆緊帶」燈②不亮。
- (3) 為了將接縫處前面的部分製成製品，按「啟動」開關⑨。
- (4) 繼續連續運轉。
→製作了 1～2 個製品後，因為「無鬆緊帶」而自動停止、「鬆緊帶」燈②會再次亮起，所以依上記 A 2 執行解除操作。

A 4 · 排除鬆緊帶供帶設備異常

- (1) 抽出卡住的鬆緊帶。
- (2) 重新安裝鬆緊帶 (P.7)。
- (3) 按「復歸」開關⑧→設備回復待機（原點）、「鬆緊帶」燈②不亮。
- (4) 長按「復歸」開關⑧後讓機器自動偵測並設定鬆緊帶的起點。
- (5) 按「啟動」開關⑨→重新啟動。

A 5 · 排除鬆緊帶供帶設備異常以外的問題

- (1) 排除供帶裝備中的鬆緊帶脫離問題。
- (2) 之後與 A 4 的 (2) 以後相同。

A 6 · 計數器累計及設定數量

- (1) 按「計數復歸」開關⑬。→累計燈④熄燈。
- (2) 按「啟動」開關⑨。→重新啟動。

A 7 · 縫紉機非待機狀態

- (1) 縫紉機操作面板的設定變更後，如 SEWING LED ⑭燈沒亮。按 READY 鍵⑮後，縫紉機進度待機狀態。
- (2) 啟動縫紉機操作面板的下線累計機能後，當螢幕數值歸零，機器會暫停（縫紉機使用說明書 P.44），交換下線後按 R（RESET）鍵⑩。

A 3 . Eliminate seam of elastic tape

- (1) Scissor the elastic tape's seam.
- (2) Press RESET switch⑧ → Light off elastic tape (ELASTIC) lamp②.
- (3) In order to make product from forefront part of seam, press START switch⑨.
- (4) Keep continuous operating.
→ After made 1~2 products, elastic tape (ELASTIC) lamp② will light up again because of "finish up elastic tape," then automatically stop the machine. Hence, cancel operation according to A2 above.

A 4 . Fix elastic tape feeding device abnormal

- (1) Pull off stuck elastic tape.
- (2) Reposition elastic tape (P.7).
- (3) Press RESET switch⑧→ Device get back to standby position(Original point) , light off elastic tape ELASTIC lamp②.
- (4) After pressed RESET switch⑧ over seconds, let machine automatically detected and setup starting point of elastic tape.
- (5) Press START switch⑨→ Restart operation.

A 5 . Fix the troubles except from elastic tape feeding device abnormal

- (1) Fix the trouble that elastic tape comes off feeding device.
- (2) After, as same as (2) of A4.

A 6 . Count up counter & amount setting

- (1) Press COUNT RESET switch⑬→ Light off count up lamp④.
- (2) Press START switch⑨ → Restart operation.

A 7 . Sewing machine isn't standby position

- (1) After changed the setting of sewing machine operation panel, If SEWING LED ⑭ didn't light up, press READY⑮ , then sewing machine would get in standby position.
- (2) When sewing machine operation panel's down thread count-up device can be used, and the machine will temporary stop when the value on panel make zero (Sewing machine instruction P.44) , exchange down thread then press RESET switch⑩.

(3) 按「復歸」開關⑧→「停止」燈①熄燈。

(4) 按「啟動」開關⑨→重新啟動。

A 8 · 排除設備內的極限開關 (LS) 異常

(1) 阻斷氣源。

(2) 電源開關設定至 OFF。

(3) 檢查極限開關。※2

【註記】※2

送帶平台移動氣缸及拉帶旋臂各有兩個極限開關，首先關閉氣閥，打開電源開關在 ON，用手推拉設備，檢查極限開關的指示燈有沒有亮。如果安裝的位置偏離就重新調整。如果安裝位置沒有偏離但指示燈沒亮，則需更換開關。

• 縫製過程中斷線後重新車縫。

(1) 將線重新穿好。※3

(2) 用 - /BACK 鍵⑫將針後退回到斷線的位置。

(3) 按「斷線再縫」⑥。→繼續縫製。

【註記】※3

針線的穿法請參照縫紉機的使用說明書。

(3) Press RESET switch⑧→ Light off STOP lamp ①.

(4) Press START switch⑨→ Restart operation.

A 8 . Fix limit switch (LS) abnormal in the device

(1) Stop the air.

(2) Turn off power switch.

(3) Check limit switch. ※2

【 Note 】※2

Each of feeding plate moving cylinder and puller hook have two limit switches. First, turn off air valve and turn on power switch. Use hands push-and-pull device to check indicator lamp of limit switch has lighten or not.

Readjust the installed position if its deviated, if not, but the indicator lamp didn't light up, you should replace the switch.

• While sewing ,re-sewing the elastic tape after broken-thread.

(1) Rethread the thread.※3

(2) Use - /BACK ⑫ to let needle back to the brocken-thread position.

(3) Press RESEW AFTER THREAD BREAK⑥. → Keep sewing.

【 Note 】※3

The method of threading thread please refer to instruction of sewing machine .

維護用運轉模式

MAINTENANCE OPERATING MODE

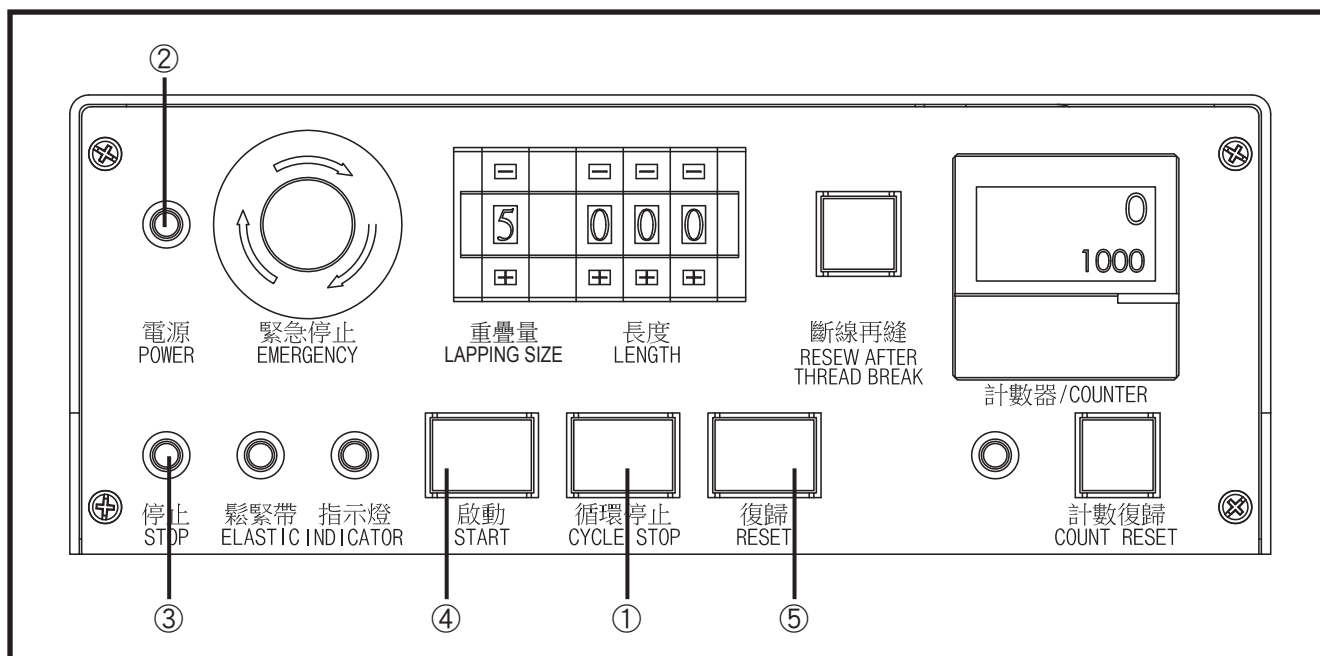

(1) 縫製一個帶圈的連續動作

可確認機器每一個動作的時機以及設備的位置關係。

1. 按壓「循環停止」開關①不放，一邊打開電源開關至 ON。
2. 確認「電源」燈②跟「停止」燈③是否同時閃燈。
3. 按「循環停止」開關①。→停止在最剛開始的暫停位置。
4. 之後，按「啟動」開關④進行分解動作。→直到帶圈準備送入縫紉機前的位置。
5. 確認帶圈狀態，按「循環停止」開關①送入縫紉機等待下一個動作的命令。「復歸」開關⑤可捨棄鬆緊帶。在這裡「啟動」開關無效。
6. 按「啟動」開關④進行分解動作。→縫製結束後回復至待機位置，繼續運轉的時候回復到 3。

(1) One shot operating for an elastic ring

Can assure every movement's timing of the machine, and relation of the device's position.

1. Press CYCLE STOP switch① and turn on power switch at once.
2. Make sure POWER lamp② and STOP lamp③ whether flashing simultaneously or not.
3. Press CYCLE STOP switch① → Stop at the first temporary stop position.
4. Hence, press START switch④ and bring work by once and once. → Till elastic ring ready to send into front position of sewing machine.
5. Assure elastic ring condition, press CYCLE STOP switch①, then send into sewing machine to wait next command .Press RESET switch ⑤ can abandon elastic tape .Not effective for START switch.
6. Press START switch④ and bring work by once and once. → After finish sewing, get back to standby position, and get back to 3 when keep operating.

(2) 機器獨立運轉

設備不運轉只有縫紉機單獨運轉。

1. 同時按「啟動」開關④與電源開關設定至 ON。
2. 確認「電源」燈②是否閃爍。
3. 以手動對位放入布料至壓腳下進行試縫。
4. 按「復歸」開關⑤的時候，縫紉機的壓腳會降下。再次按「復歸」開關⑤時壓腳會上升。
5. 按「啟動」開關④，機器就會運轉。

(2) Machine isolated operation

Only sewing machine isolated operation, without device operation.

1. At the same time press START switch④ and turn the power switch on.
2. Make sure POWER lamp② flashing or not.
3. Fix the cloth position by hands, and put the cloth in till presser clamp start to try sewing.
4. Presser clamp will low down after press RESET switch⑤. Presser clamp will rise up after press RESET switch⑤ again.
5. Press START switch④, the machine will operate.

各部分的調整・維修

THE ADJUSTMENT & MAINTENANCE OF EACH PARTS

(1) 鬆緊帶定位及送帶設備的前後位置

1. 切斷氣源，調整鬆緊帶定位器①和針板孔的間隔為 4.5~5 mm。(調整) 放鬆螺絲②後調整。
2. 鬆緊帶送至壓腳下的時候，鬆緊帶的內側與定位器①相接。(確認方法) 維護用運轉模式下確認製品在壓腳下的位置。這時確認帶圈與定位器①是否接合，有一點點的空隙(0.5mm 以內) 是最好的。

(1) Fore and rear position of elastic tape locating and feeding device

1. Stop the air blow, adjust elastic tape locator① and needle hold about 4.5~5mm distance. (Adjustment) Loosen screw② then adjust.
2. The inner side of the elastic tape and locator① connected, when elastic tape is sending under press clamp. (Checking method) Check the product is under the press clamp when the operation is under the maintenance operating mode. At the time, make sure whether elastic ring and locator ① are jointed, has a little space (within 0.5mm) is the best.

【注意】

鬆緊帶被定位器①壓住的狀態下，製品上浮將是斷線或縫製不良的原因。這時可調整送帶設備的前後位置。

•送帶設備的前後位置調整方法

放鬆螺絲③（五個地方），把底座④順著引導板⑤前後移動。調整後，先鎖緊底座④的三顆螺絲再將送帶設備後位置固定板⑥的兩顆螺絲鎖緊於底座④上。

【 Caution 】 In the situation which elastic tape be pressed by locator①, product puff up will be the reason of thread breaking or reject.

•Adjusting method of fore and rear position of feeding device.

Loosen screw③ (Five spots) , move base plate④ back and forward with guide plate⑤. After adjustment, tighten the three screws of base plate④, then tighten two screws of fixed plate⑥ which behind the feeding device on base plate ④.

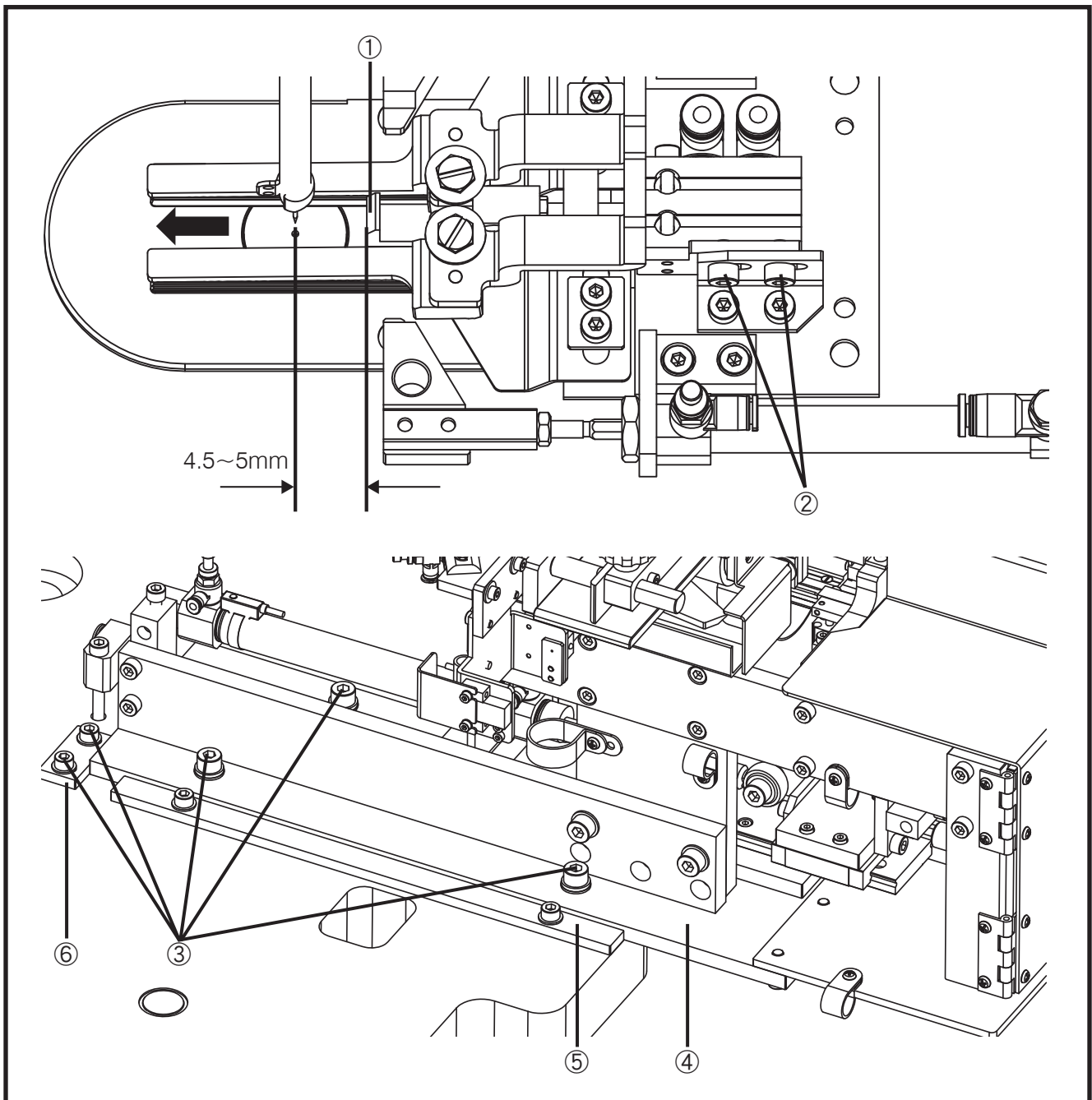

(2) 帶端接合位置偏離調整

- 帶圈右端向內側偏離時（左下圖）。
- 調整方式：鬆開螺絲①，把夾爪②往箭頭③方向移動（微調）。

【註記】

依照右下照片的位置將鬆緊帶的側面④⑤接線變形的程度，以目測調整。

- 鬆緊製品右端如往外側偏離時，則朝上記的反方向調整。

(2) Adjust deviation of tape side end joint

- Right end of elastic ring slip to inner side. (Left picture below)
- Method of adjustment: Loosen screw①, and move tape puller② to arrow③ direction. (Fine adjustment)

【 Note 】

According to position of right picture below, adjust changed- shape by visually confirm elastic side ④⑤ connecting line.

- If elastic product right side slip forward, adjust counter direction as above.

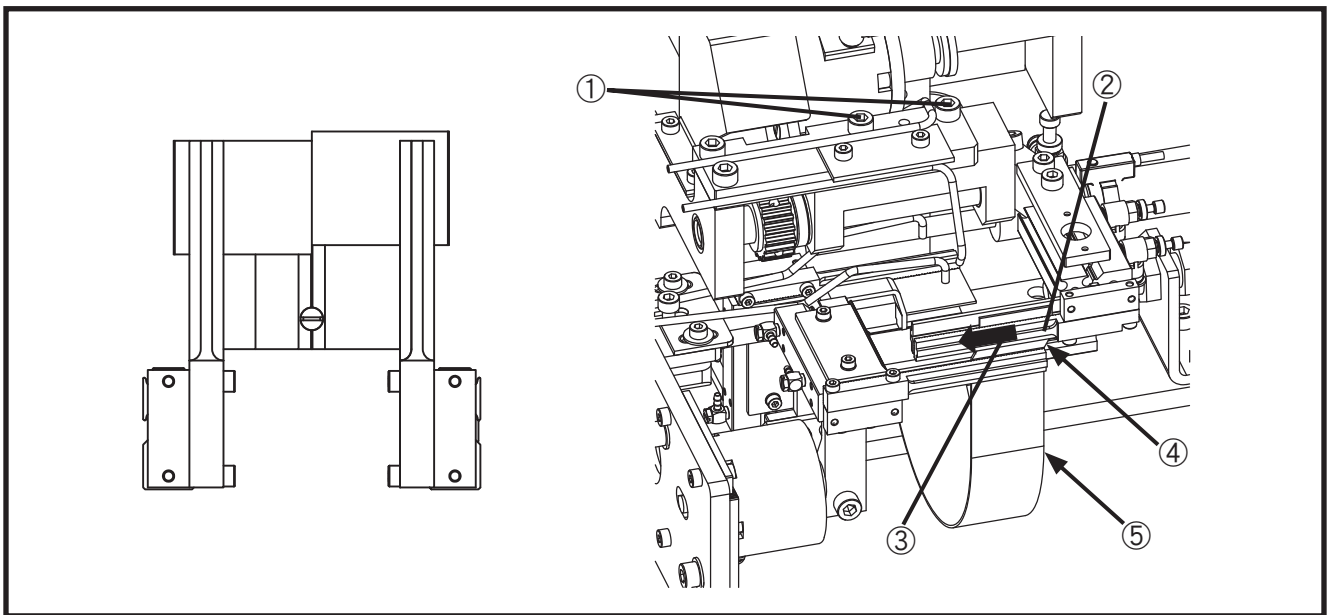

(3) 氣壓的強度調整

氣壓管⑥～⑨的吹氣強度不一，是依各節流閥調整。

(3) Adjustment of pneumatic intensity

Air blowing different intensity of air nozzles⑥～⑨ is adjust with following throttle valve.

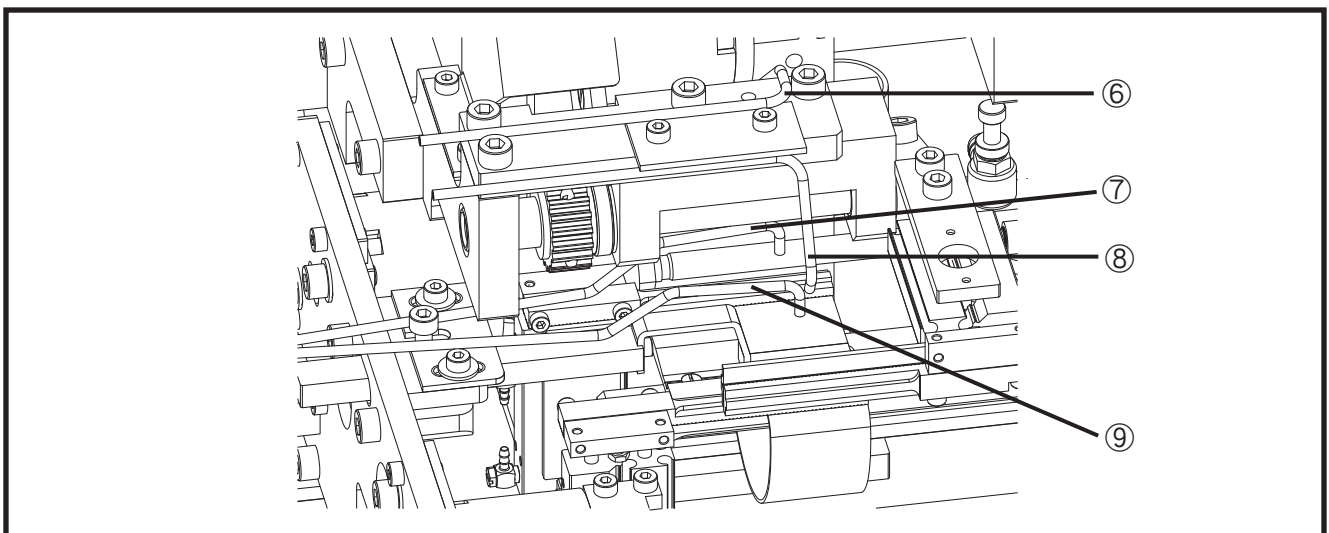

(4) 輸送滾輪的調整

• 輸送滾輪①上的鬆緊帶往箭頭方向偏離的時候需要調整。

1. 鬆開螺絲④。
2. 向右下圖一樣，將輔助輪⑤調整稍微傾斜輸送滾輪①上的鬆緊帶往箭頭方向偏離的時候需要調整。

(4) Adjustment of feeding roller

• Elastic tape on the feeding roller① need to adjust if it slip to direction of arrow.

1. Loosen screws④.
2. Like right picture below, adjust auxiliary roller⑤ fine tile to feeding roller①.

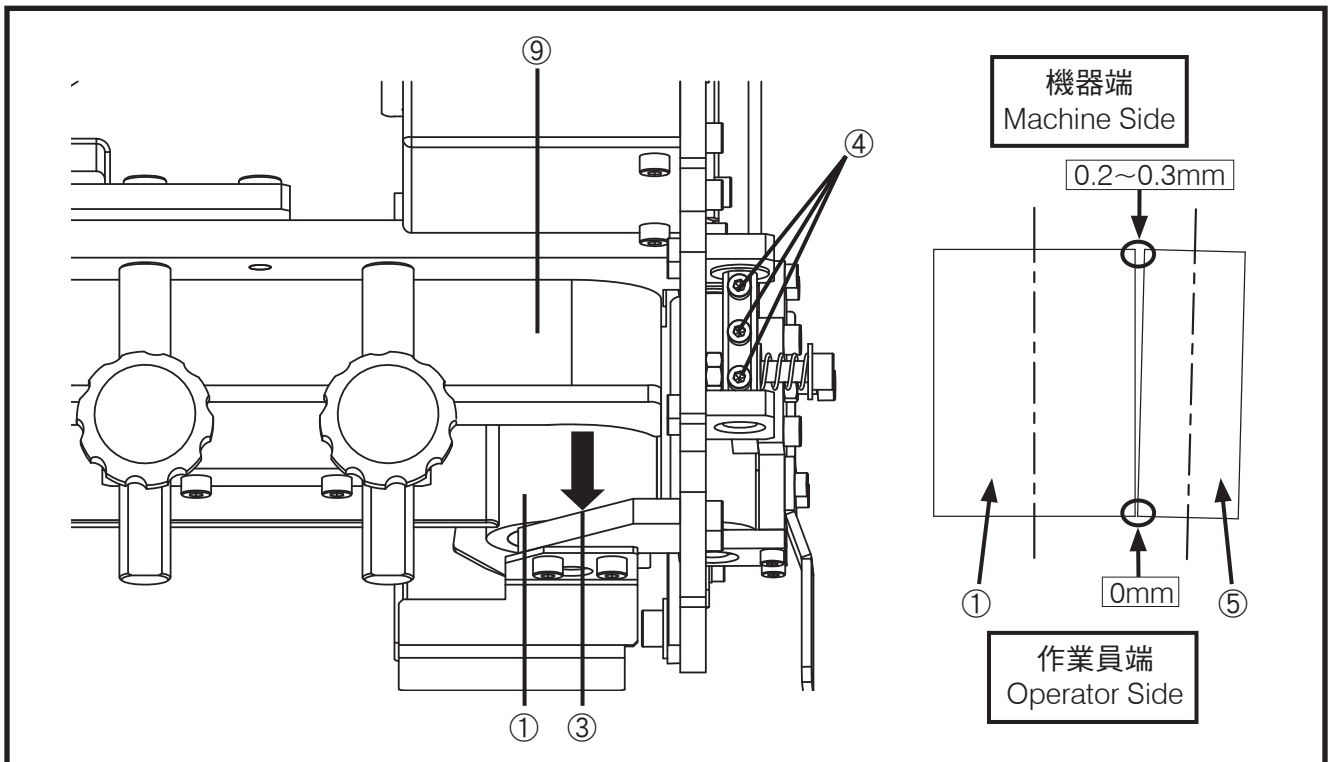

(5) 機器壓腳及托布板的調整標準

1. 將針卸下，進入縫紉機單獨運轉模式。
2. 設定縫製式樣。
3. 按「復歸」開關⑥後，降下壓腳。
4. 按 + /FORWARD 鍵⑦後，壓腳⑧跟托布板⑨移動最右或最左時，讓針孔的中心點和托布板⑨的內側間隔 1.5 mm。
5. 壓腳⑧內側比托布板⑨內側更往外 1.5 mm，(從針孔中心往外 3 mm)。
6. 將托布板、壓腳上的螺絲分別鬆開後調整。

(5) Adjustment standard of machine presser cramp and fabric holding plate

1. Pull off needle and get into sewing machine isolated operation mode.
2. Setup sewing pattern.
3. After press RESET switch⑥, lower presser cramp.
4. After press + /FORWARD⑦, when presser cramp⑧ and fabric holding plate⑨ move to right end or left end, adjust center of needle hole and inner side of fabric holding plate⑨ about 1.5mm distance.
5. Inner side of presser cramp⑧ outside forward 1.5mm than fabric holding plate⑨. (Outside forward 3mm from center of needle hole.)
6. Loosen then adjust the screws of fabric holding plate and presser cramp separately.

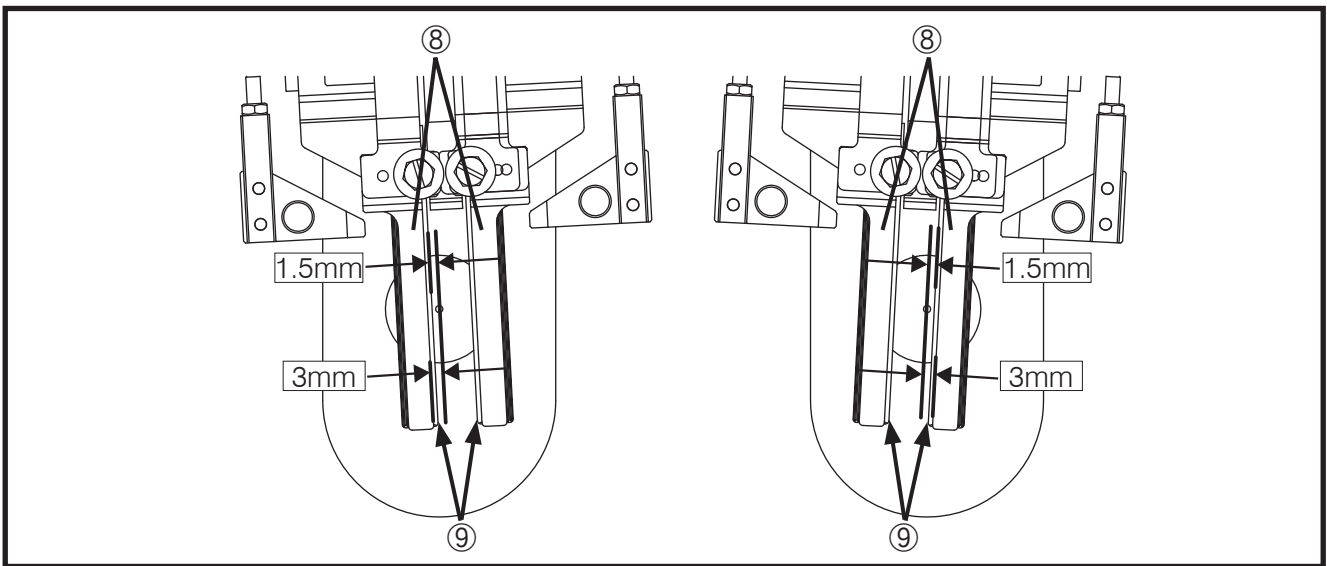
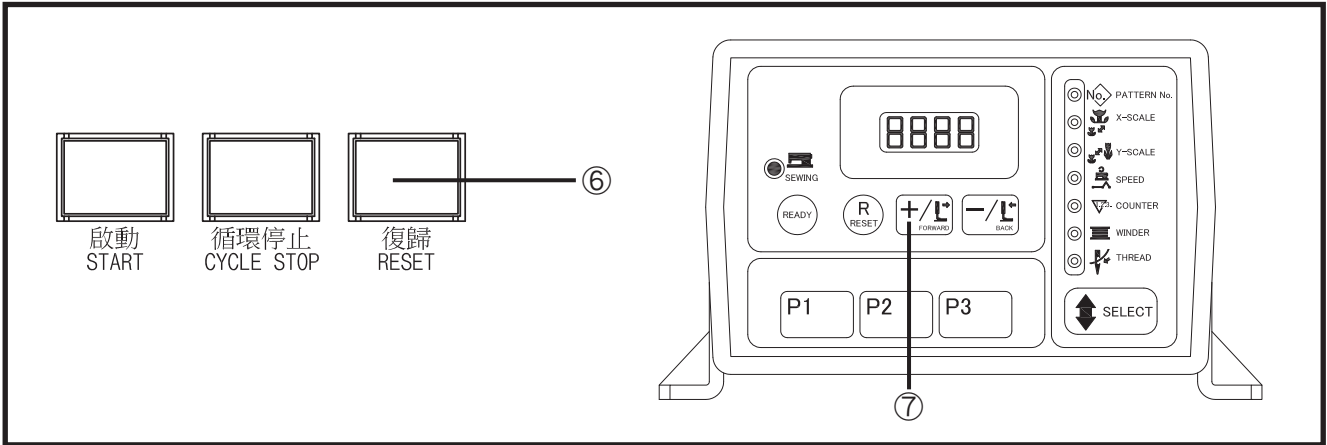

(6) 接縫檢測器或是鬆緊帶殘餘量感應器

• 接縫檢測接器的調整

1. 鬆開螺絲③。
2. ①的部分通過接縫檢測器的時候，把開關②水平移動調整到開關啟動且發出聲音的位置。

(6) Joint seam detector or elastic tape remains sensor

• Adjustment of joint seam detector

1. Loosen screws ③.
2. As part① through joint seam detector, level move switch② until switch on and the position which noise making.

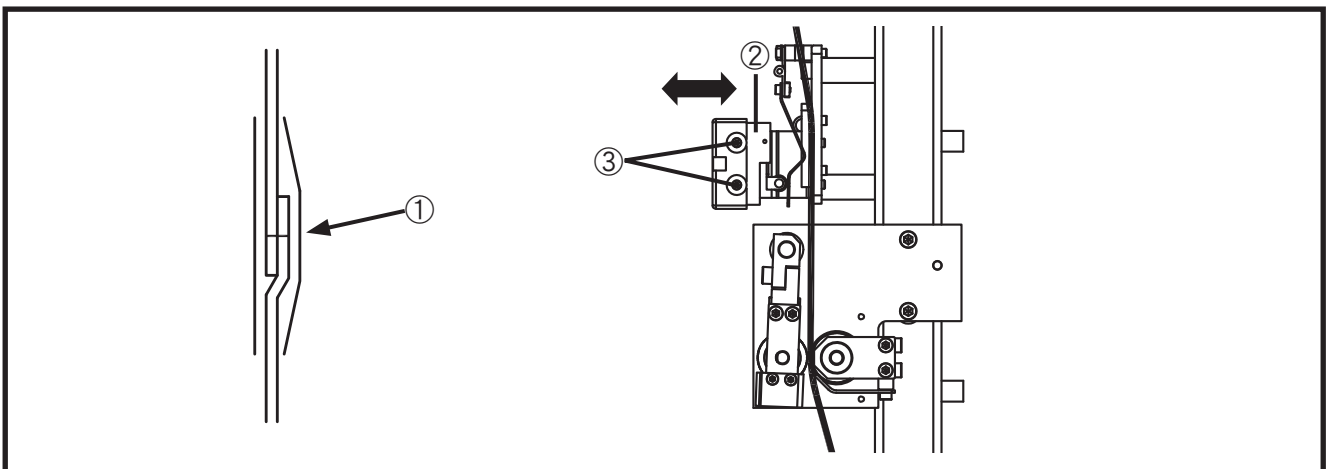

殘餘量感應器如果遇到白色或是材質較薄的鬆緊帶時，由於光線穿透，導致檢測裝置誤判的時候需調整感應器④。（只要以最容易誤判的鬆緊帶做調整，往後不需要再調整。）

• 調整方式：

1. 打開電源開關至 ON。
2. 將誤判的鬆緊帶通過檢測裝置中間。
3. 移動感應器④（將感應器④斜向安裝）降低敏感度。
4. 檢查感應器受光部分的指示燈（在感應器的右側，只有在沒有帶子的時候會亮燈）確認調整效果。

If remains detector encounter elastic tape which are white or sheer, adjust sensor④ if light pass through that cause detector device in error judgment. (No need to adjust the sensor ever after fixed with the most sheer material)

• Adjustment method

1. Switch on the power source.
2. Let elastic tape which in error judgment through the middle of detecting device.
3. Move④ (Tilted install sensor④) to lower sensitivity.
4. Check the indicator lamp which on the light receiving section of sensor. (At the right side of the sensor will light up only without elastic tape) Check the adjustment effect.

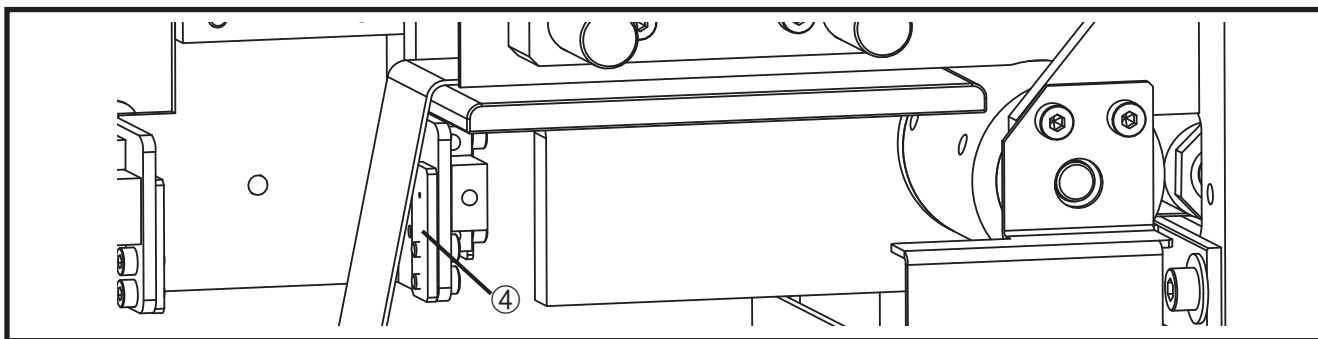

(7) 切帶刀的更換及調整

• 活動刀及固定刀的更換方法

1. 取下外殼①、外殼②。
2. 外殼③則是將卸下螺絲④。
3. 更換活動刀⑤的時候卸下螺絲⑥後執行。

(7) Replacing knife and adjustment

• Replacing method of moving knife and fixing knife.

1. Take off covers ①②.
2. Take off screws ④ for cover③.
3. Operate after replacing moving knife⑤ then take off screws ⑥.

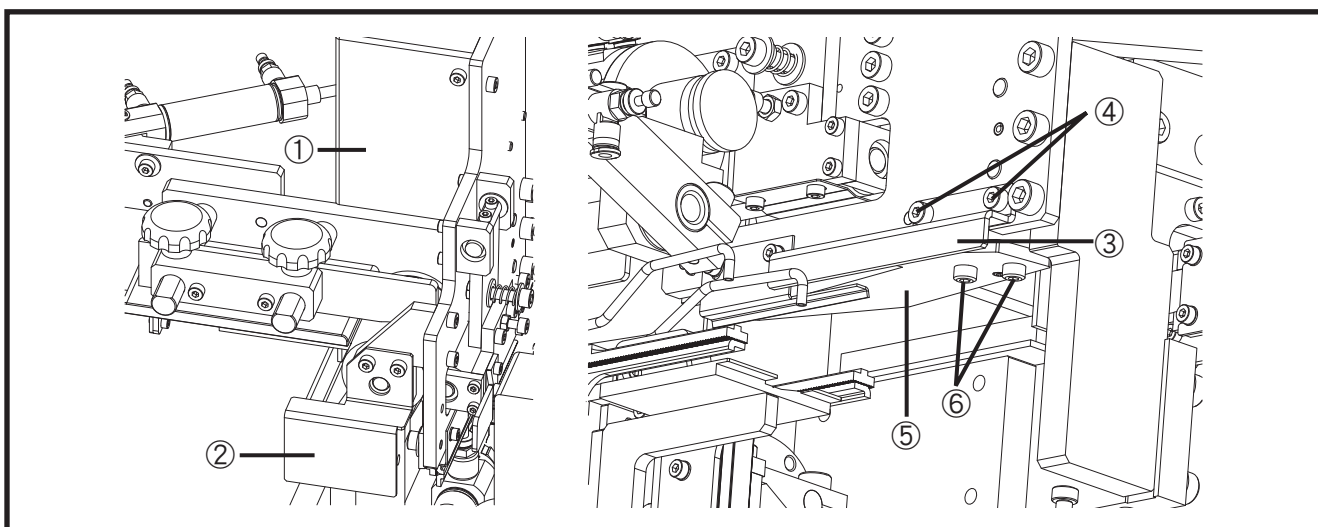

4. 固定刀⑦的更換則是螺絲⑧⑨卸下後開始。
 • 固定刀⑦的安裝標準：固定刀⑦的刀鋒部分要比底座⑩更向下 2 mm。

4. Replacement of fixing knife⑦ is starting after take off screws ⑧⑨.
 • Standard installation of fixing knife⑦: Fixing knife⑦ blade edge is lower 2mm than base plate⑩.

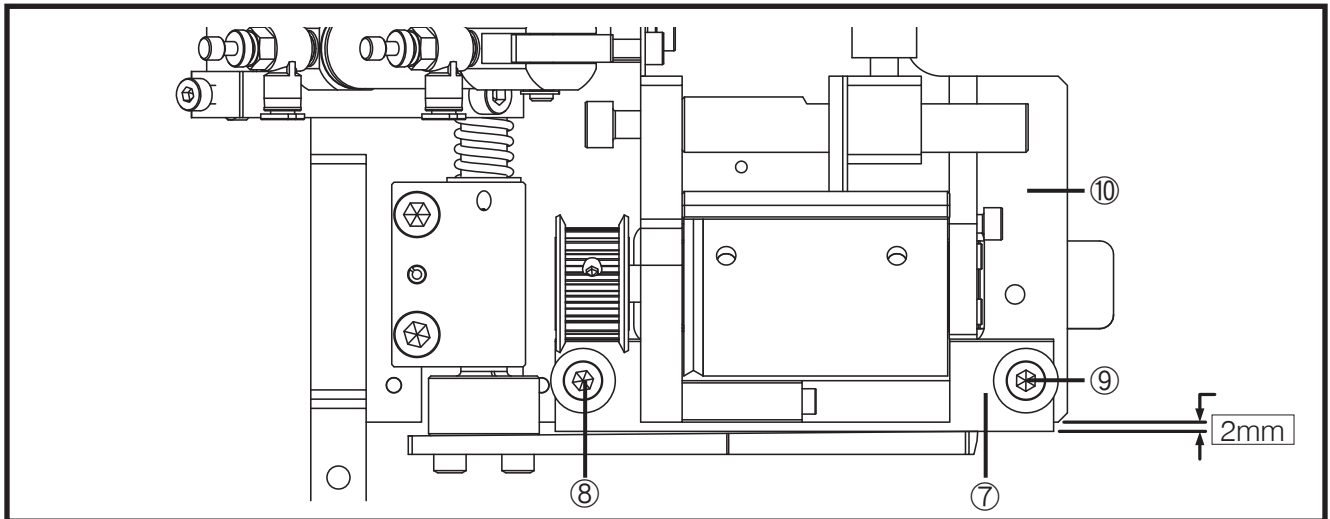

• 切帶刀的調整標準

- (1) 如下圖所示鋼柱①的部分標準尺寸是 14mm。(切帶刀的咬合壓力調整方法：鬆開螺絲②後進行調整。)
 (2) 上述的狀況下，活動刀③與固定刀接觸的時候，下圖④空隙較大的部分，活動刀③及固定刀⑤之間請間隔 0.2~0.3 mm。鬆開螺絲⑥後進行調整。

【註記】

④的部分如果間隙太大，因為切帶不良反而會使刀具提早耗損。

• Standard adjustment of knife

- (1) Like picture below, standard size of steel pillar① is 14mm. (Adjustment of knife lapping pressure: Adjust after loosen screw②.)
 (2) In the situation above, when moving knife③ and fixing knife closed, picture below, ④ which slit is larger, adjust the slit between 0.2~0.3 between moving knife③ and fixing knife⑤. Adjust after loosen screws ⑥.

【Note】

If part ④ slit too large, it will worn out knife faster because of bad cutting.

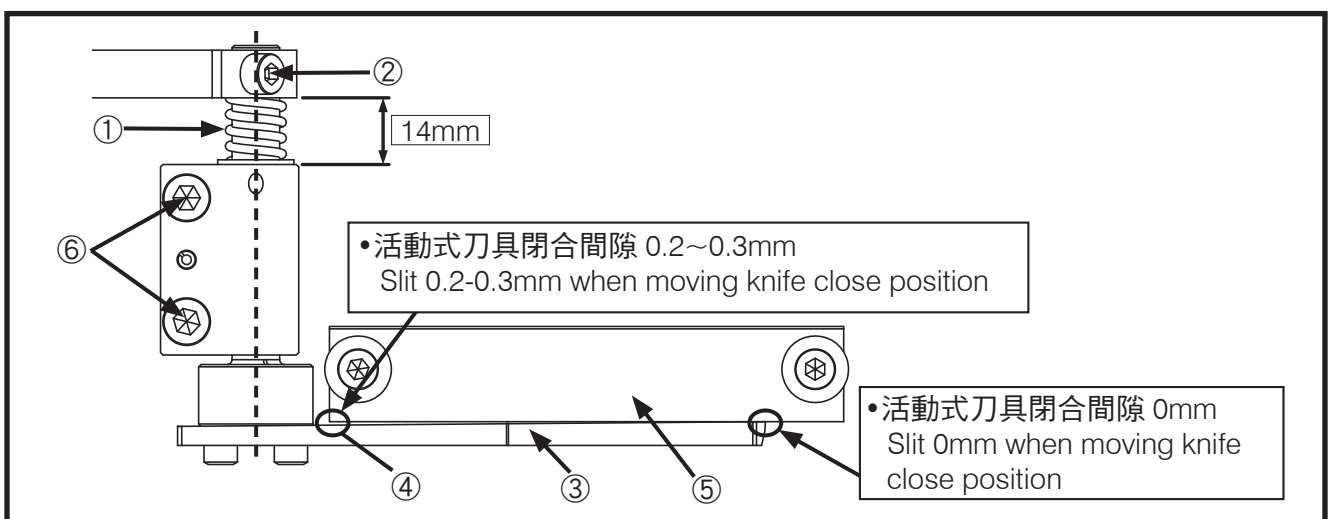

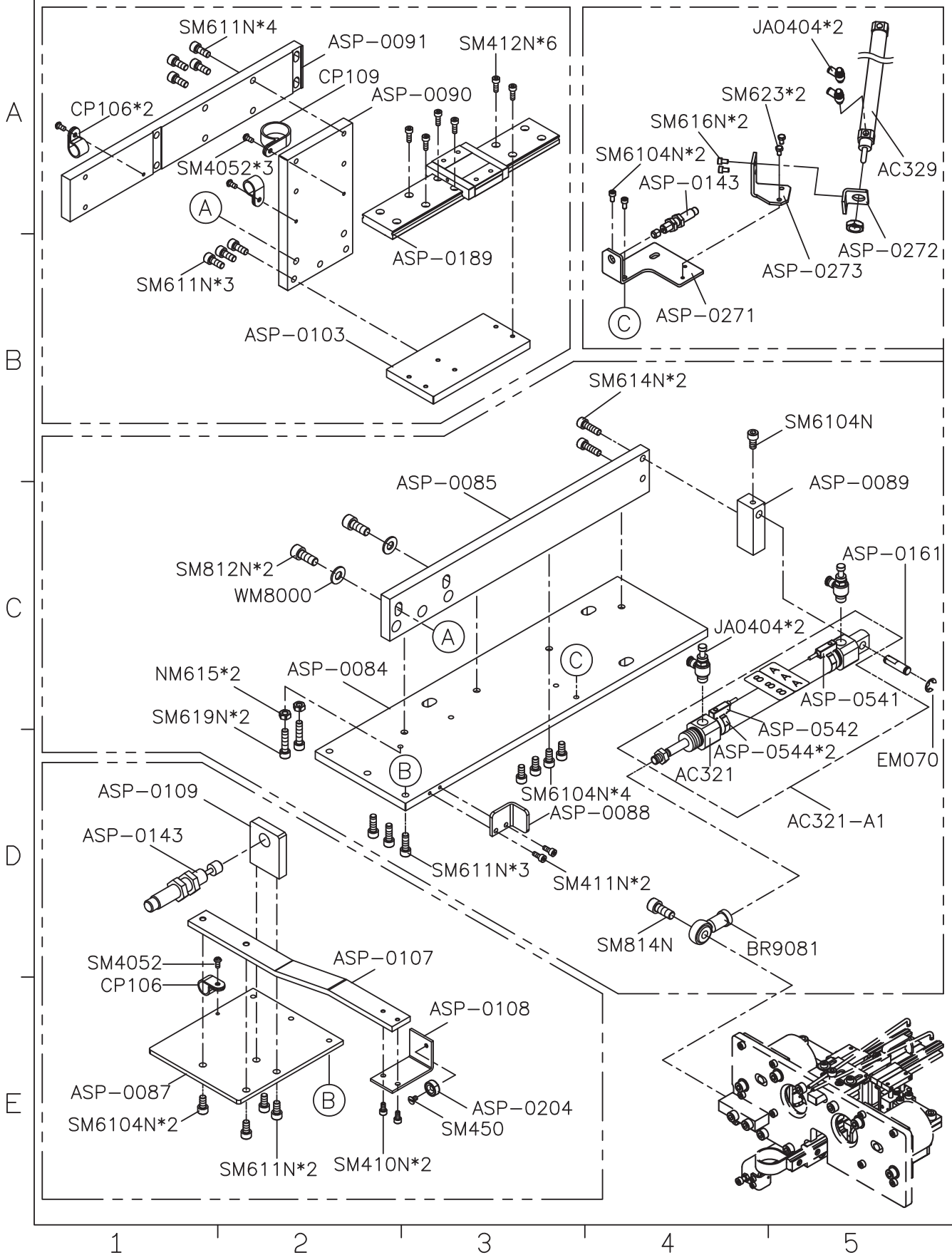

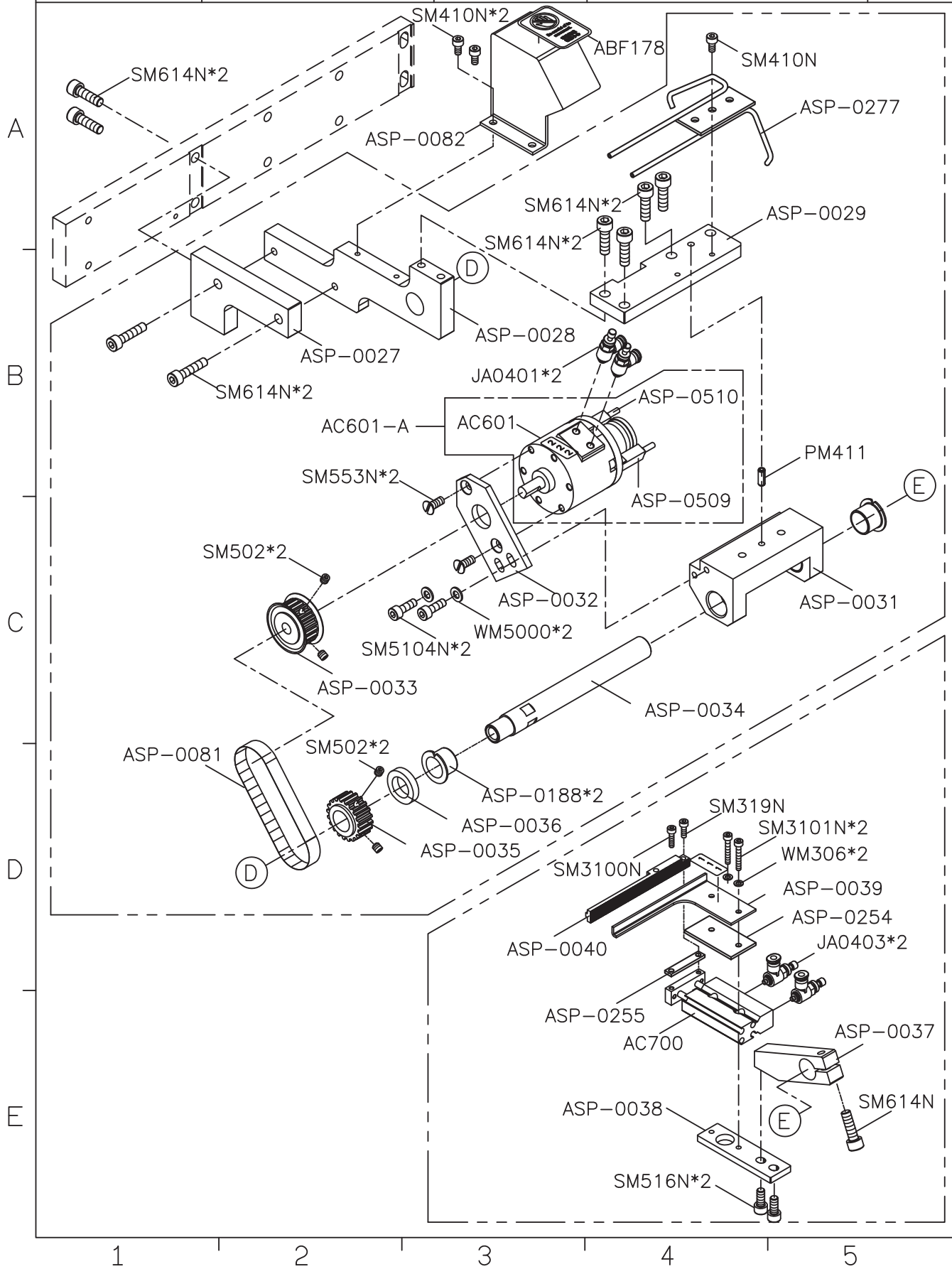

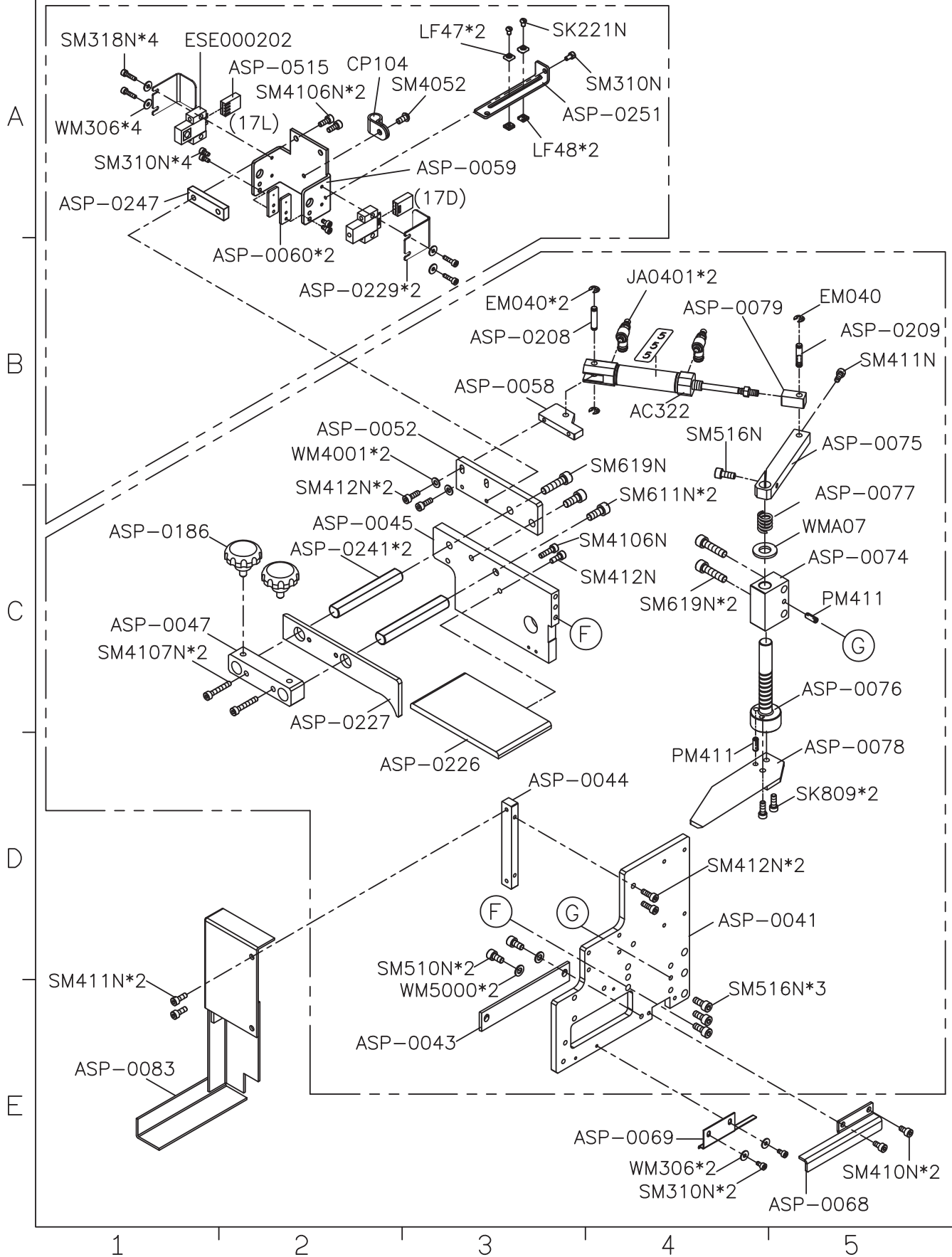

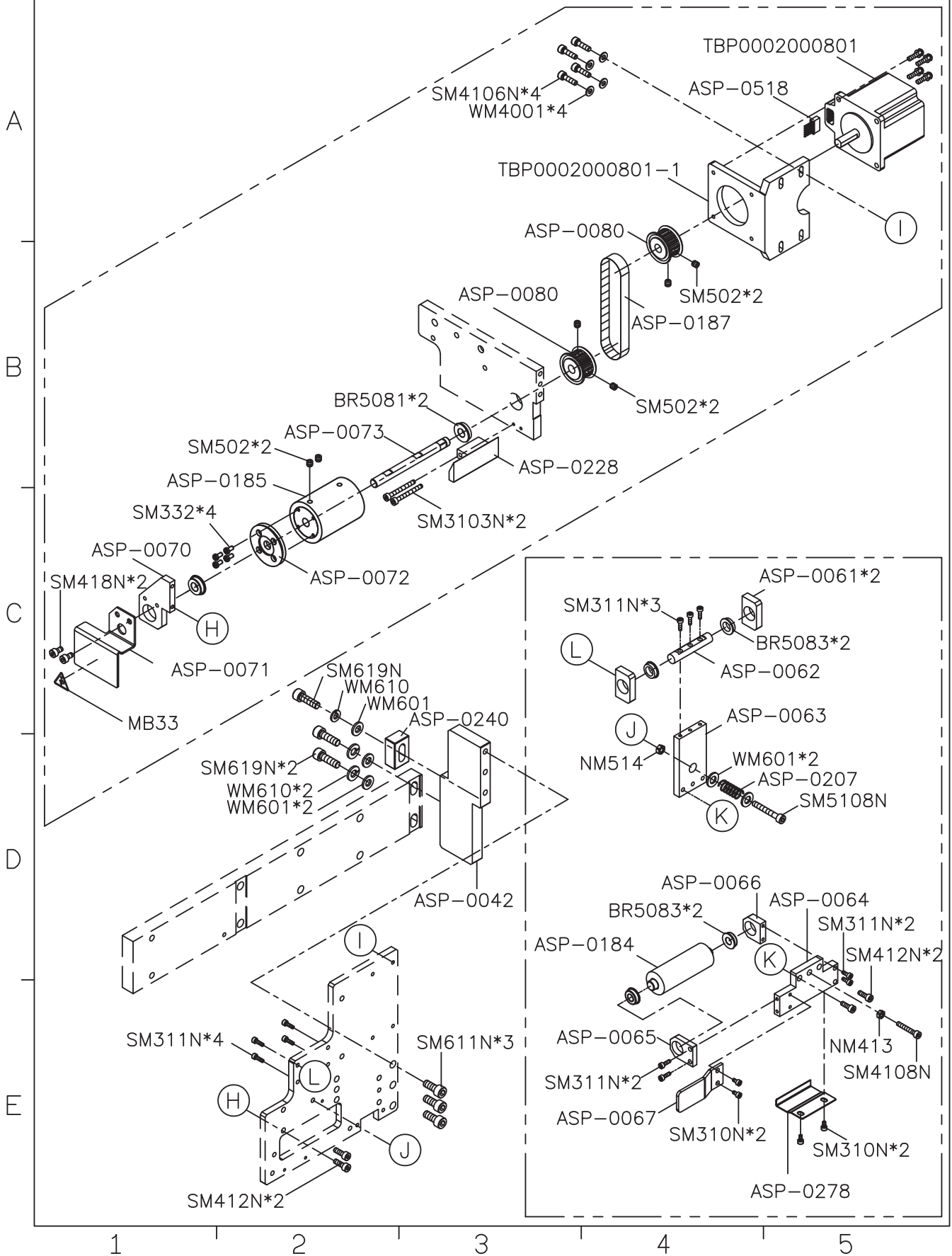

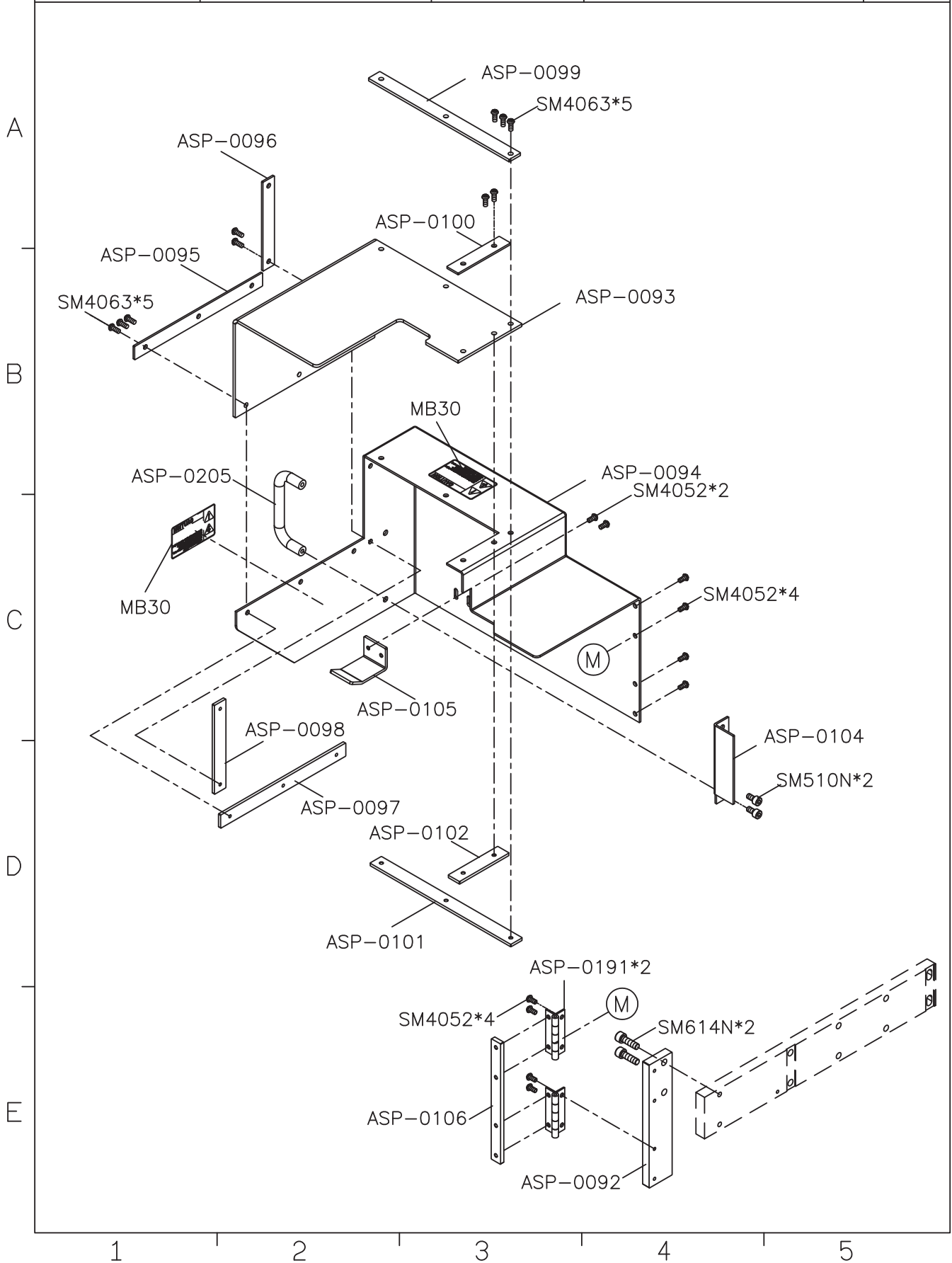

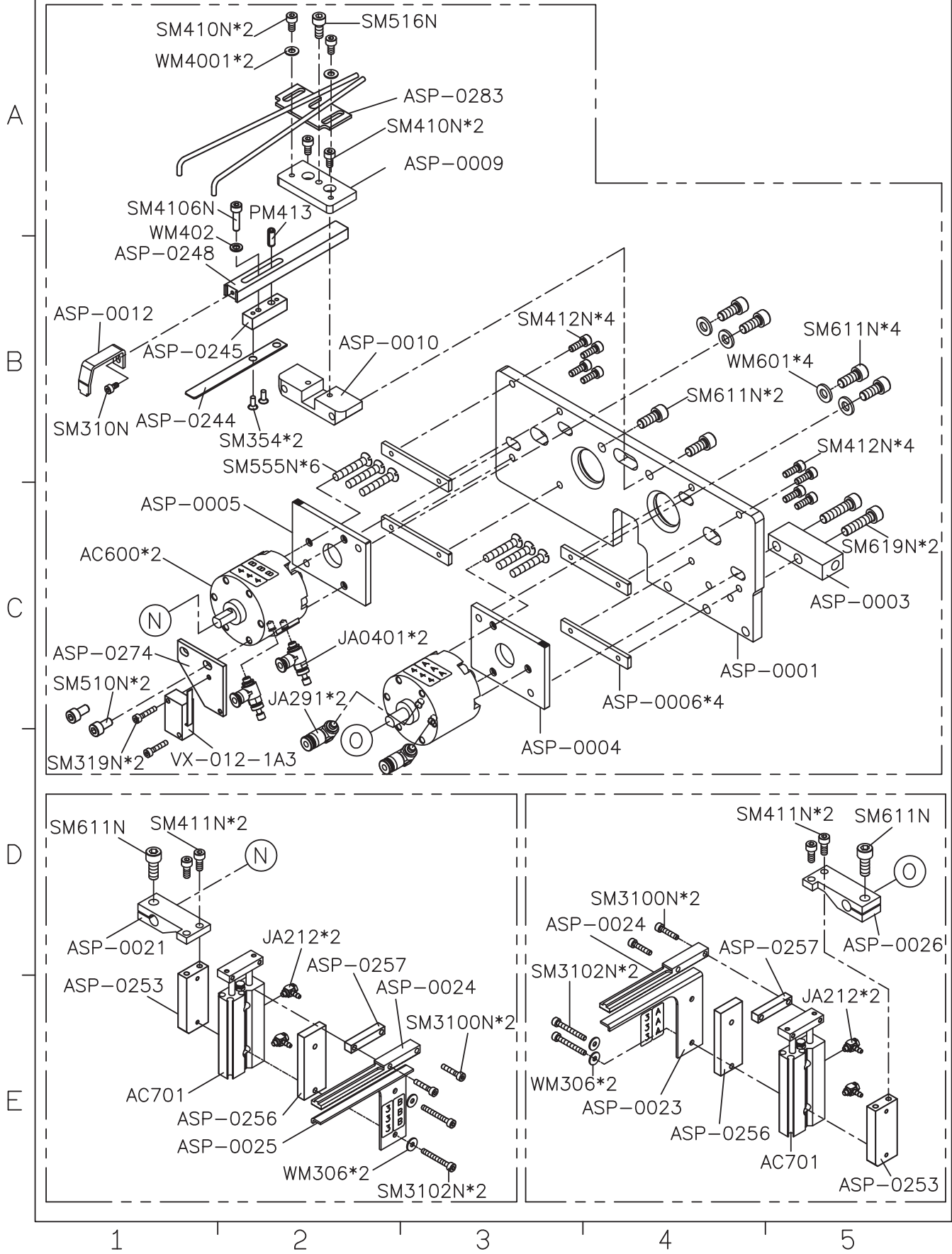

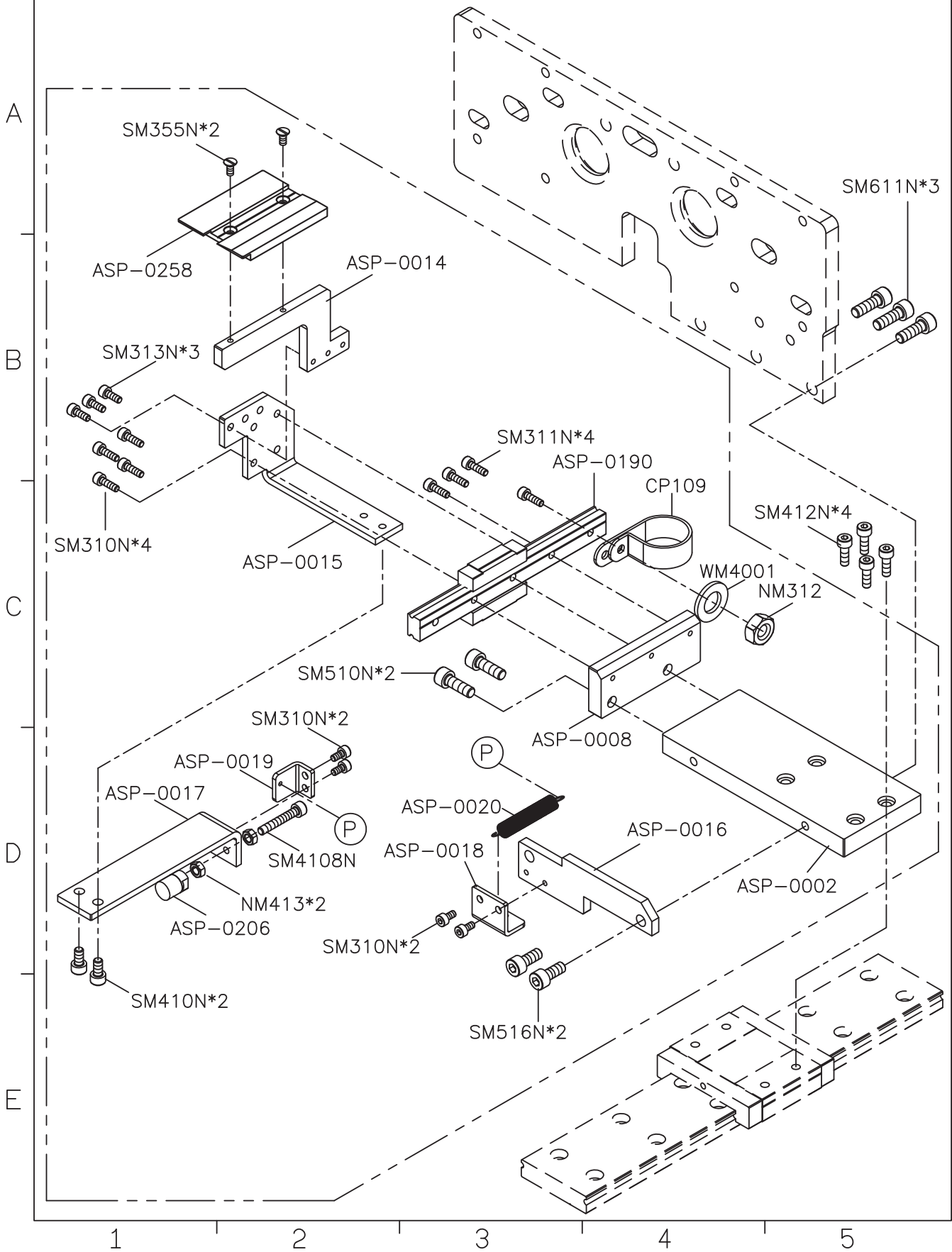

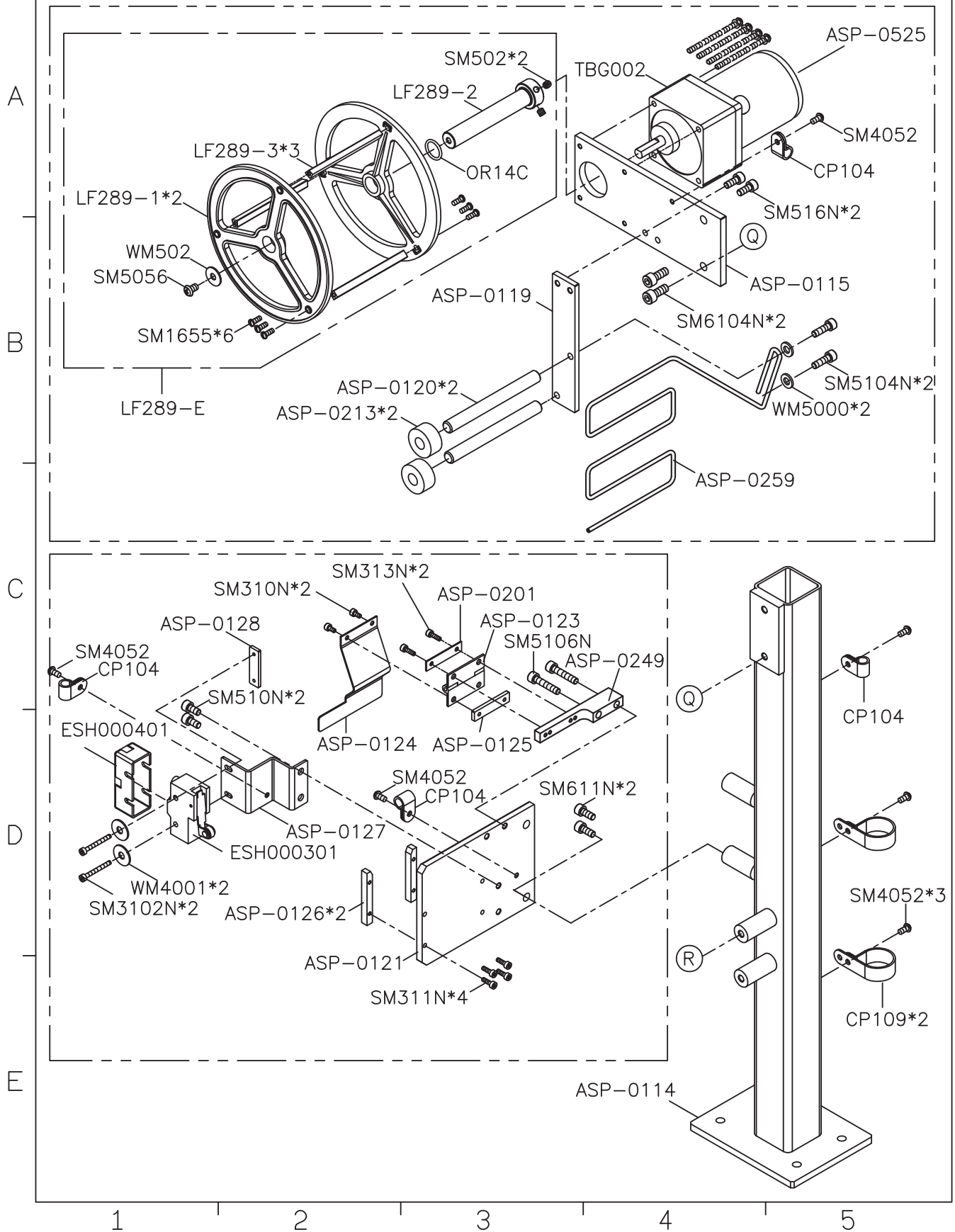

SIRUBA PARTS LIST	Series	Parts Group	Subclass Remark	Page
	ASP-EBJ100S	ASP		9/20
				Date
				2016/09/13

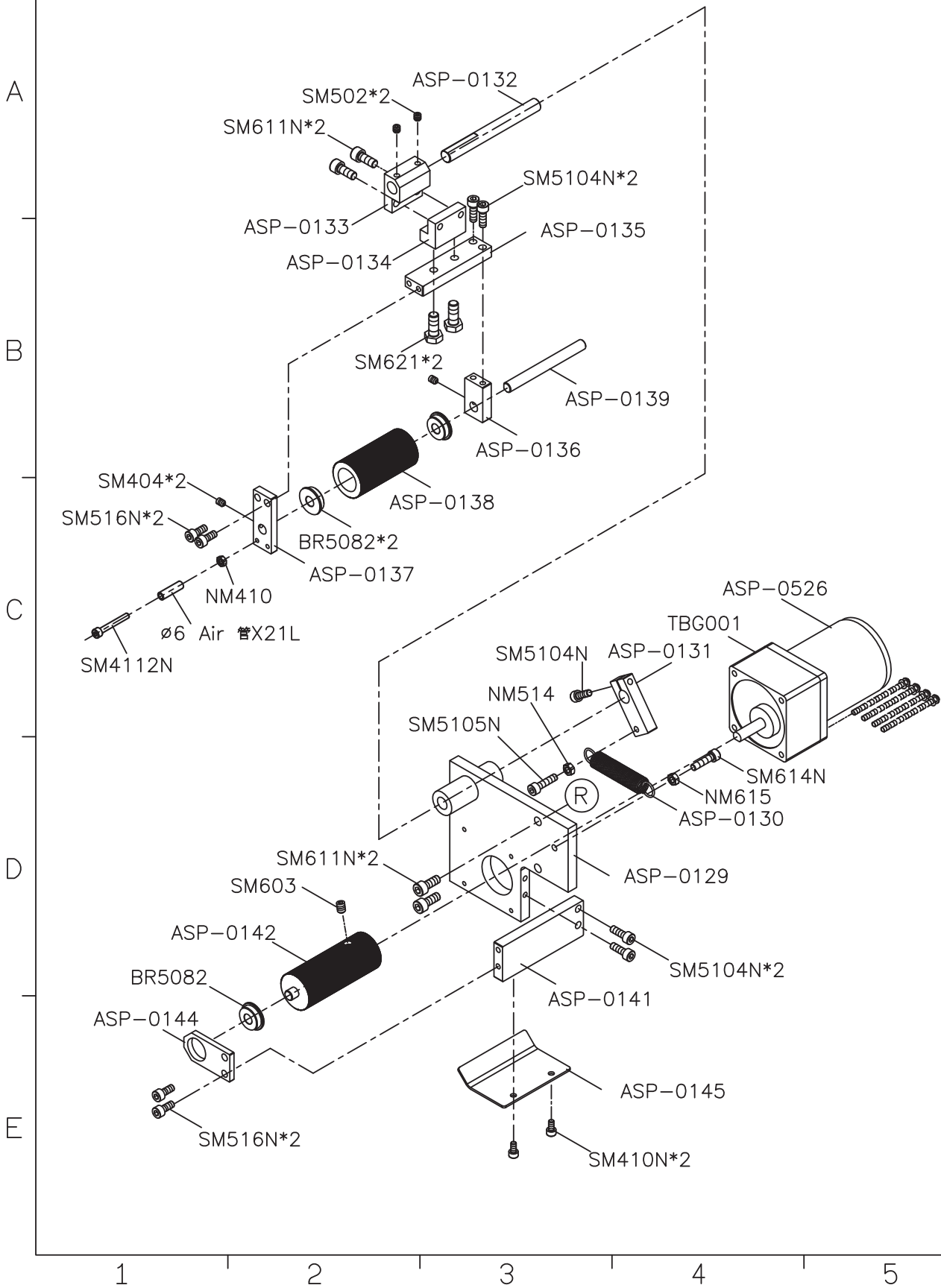

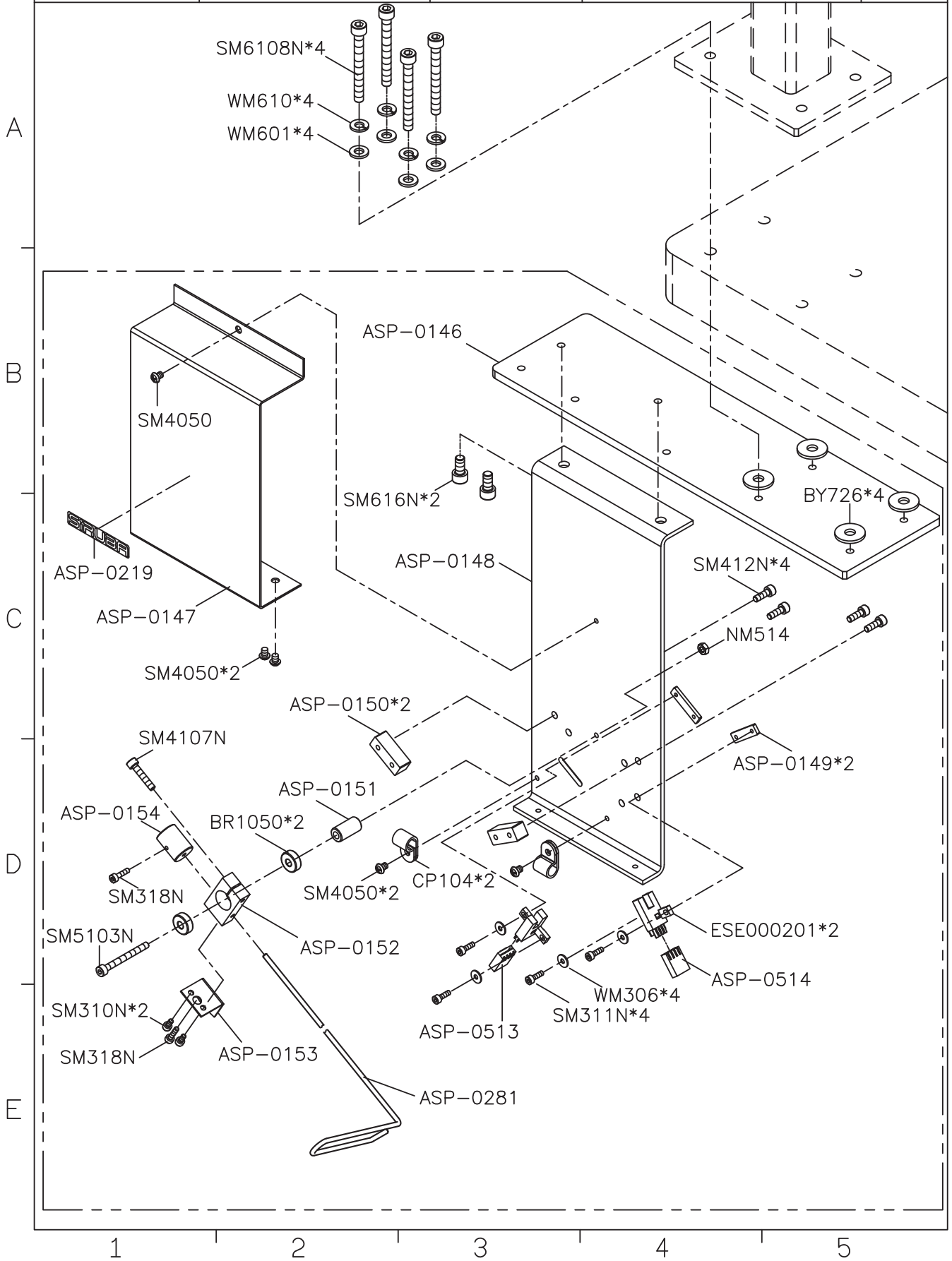

SIRUBA PARTS LIST	Series	Parts Group	Subclass Remark	Page
	ASP-EBJ100S	ASP		11/20
				Date
				2016/10/19

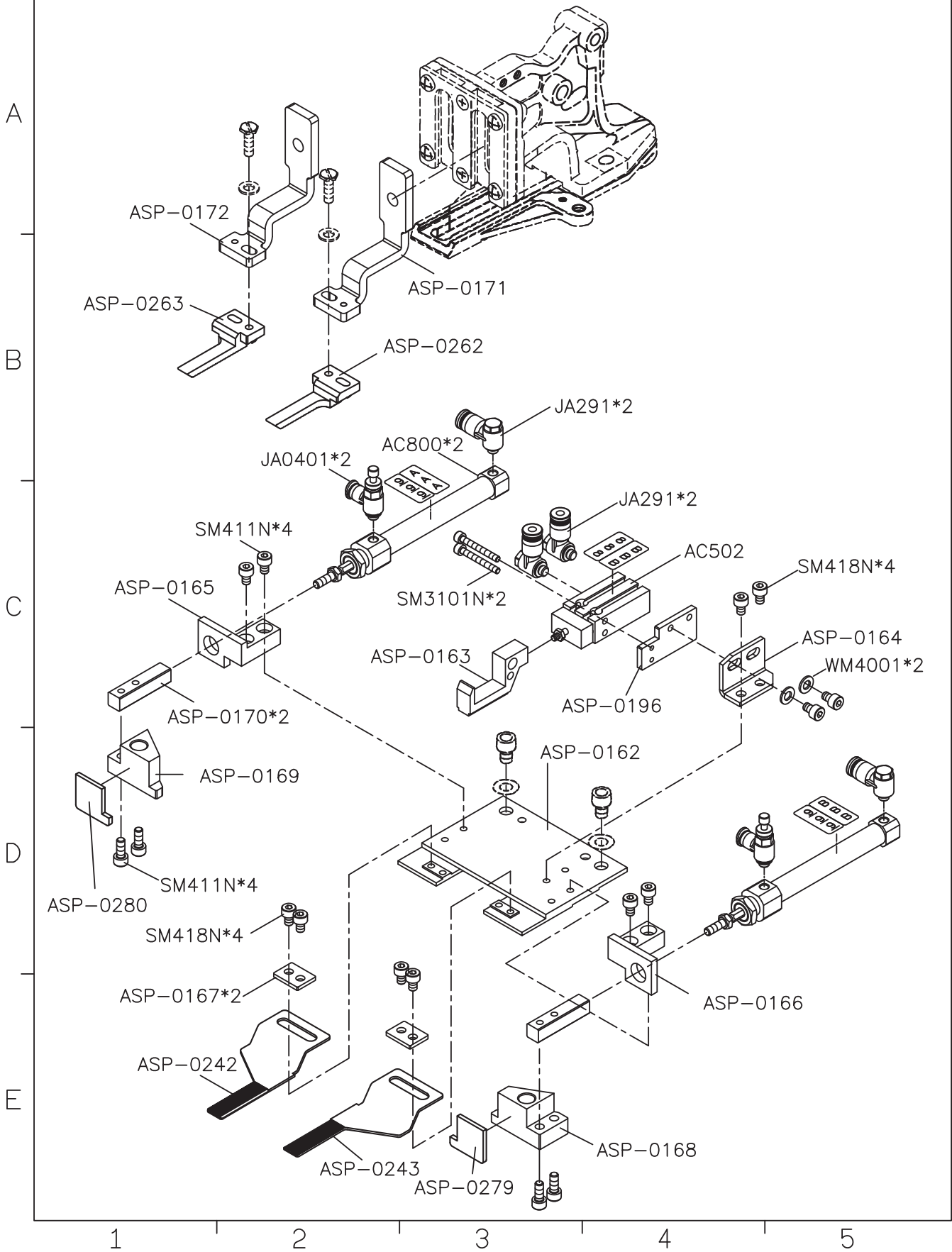

SIRUBA

PARTS LIST

Series

ASP-EBJ100S

Parts Group

ASP

Subclass Remark

Page

12/20

Date

2017/03/16

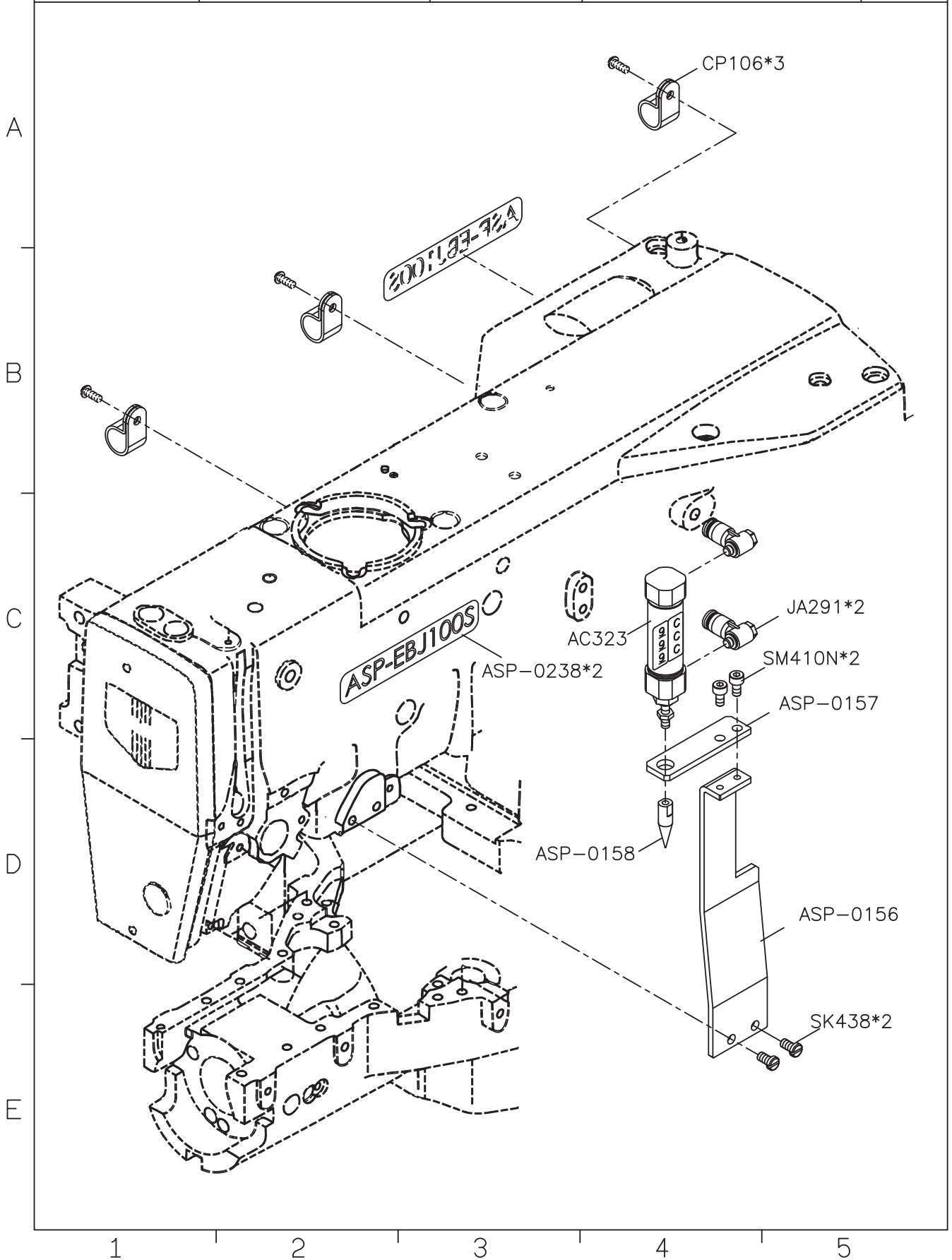

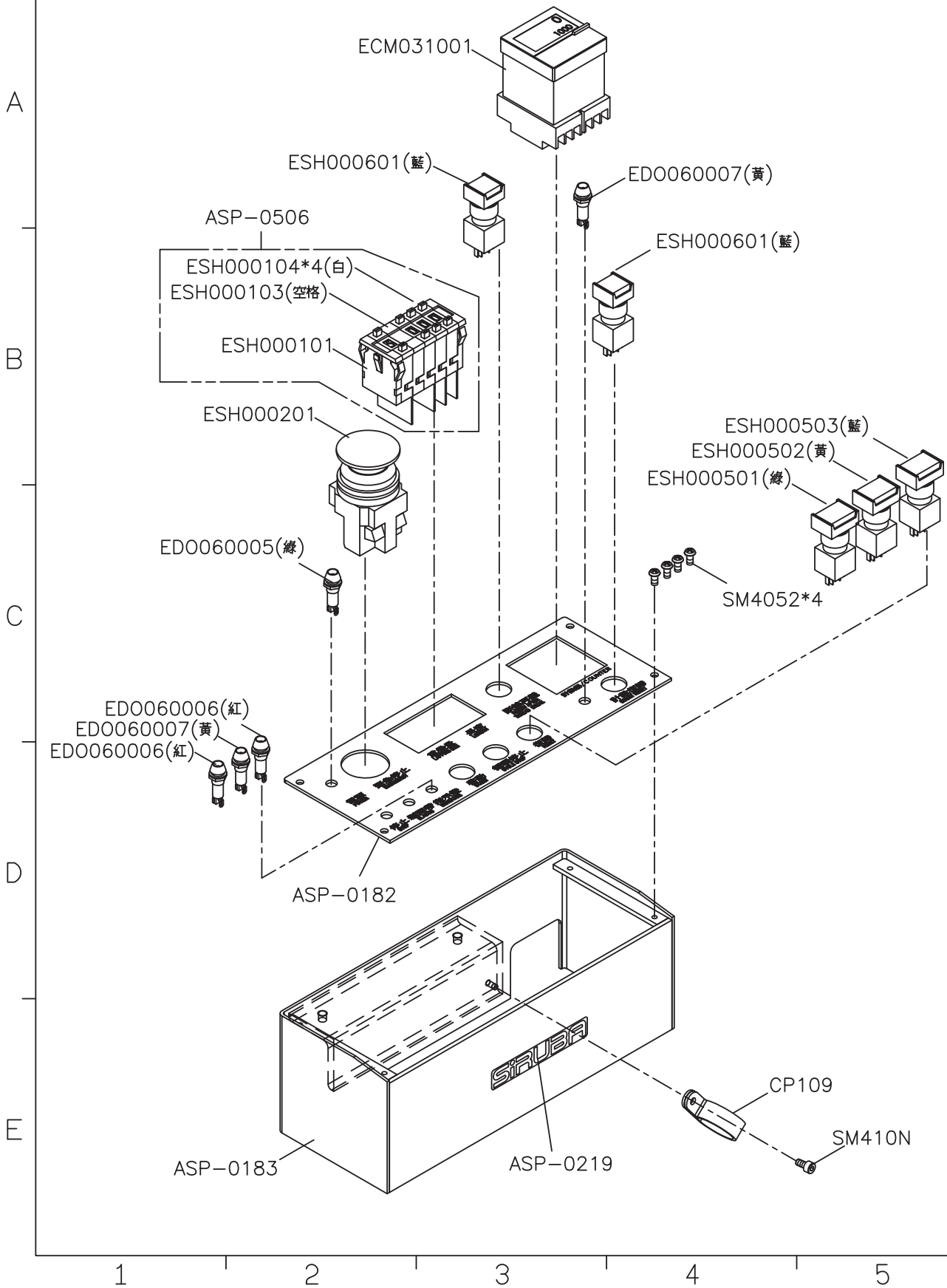

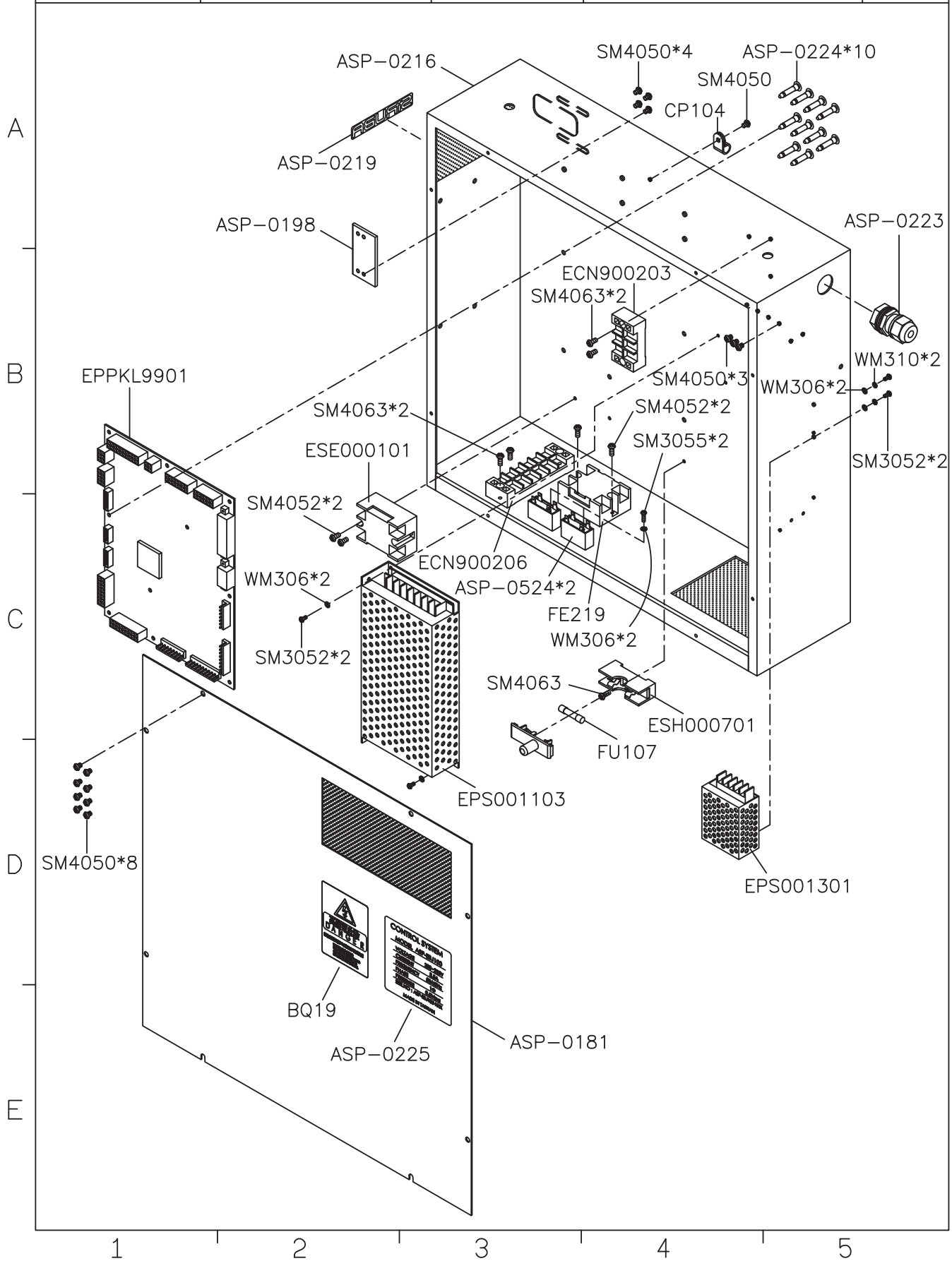

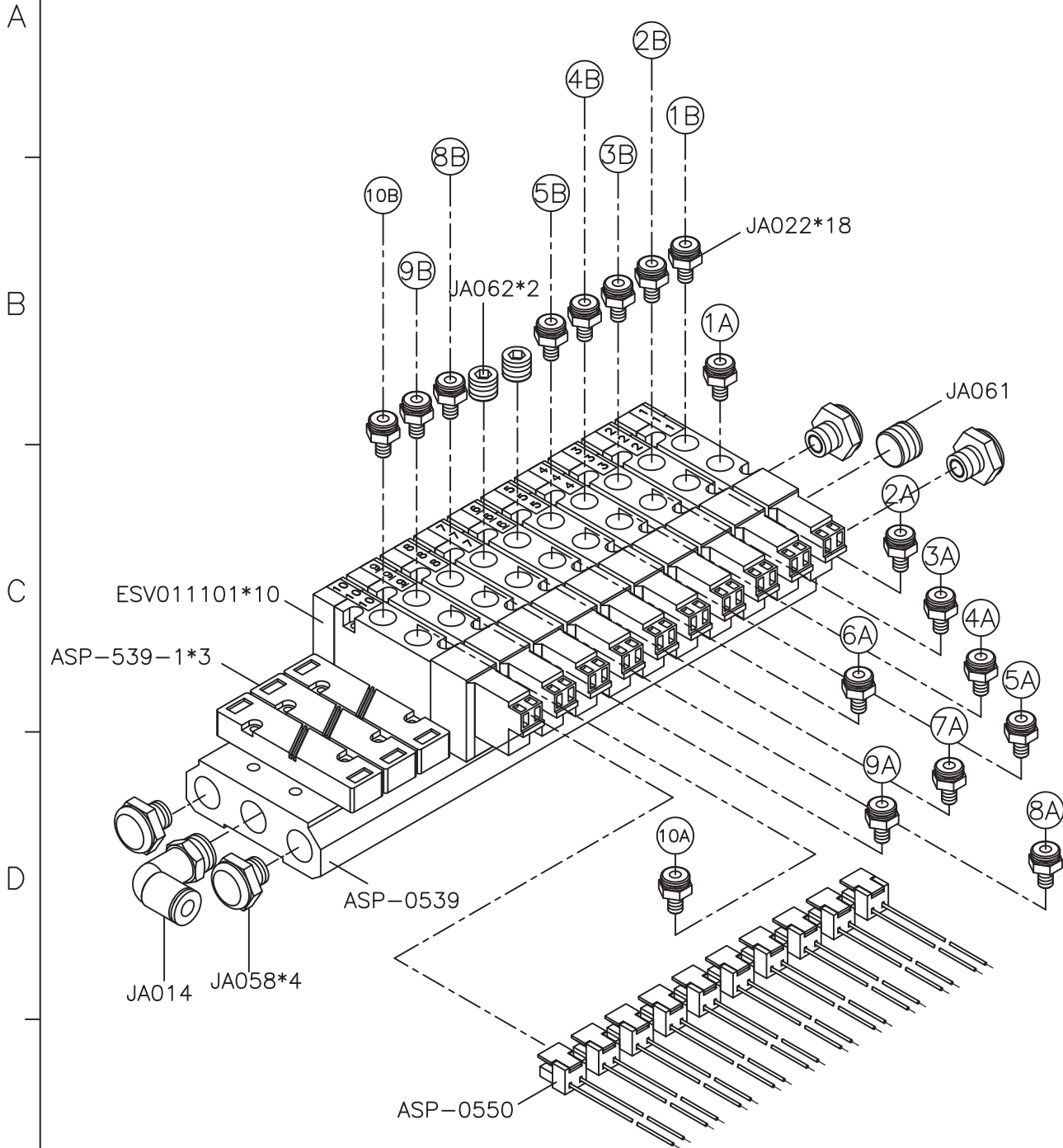

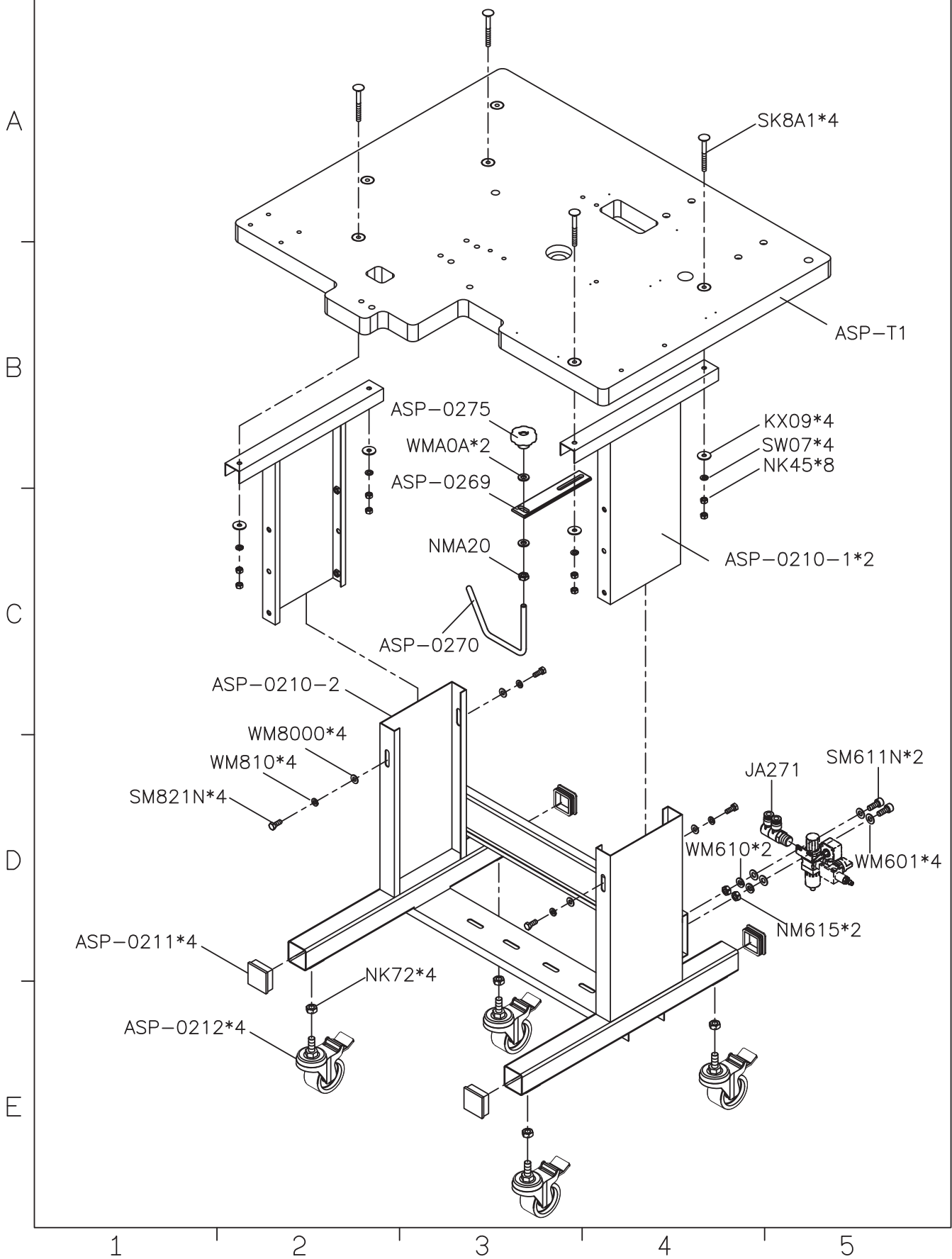

SIRUBA PARTS LIST	Series	Parts Group	Subclass Remark	Page
	ASP-EBJ100S	ASP		17/20
				Date
				2017/03/15

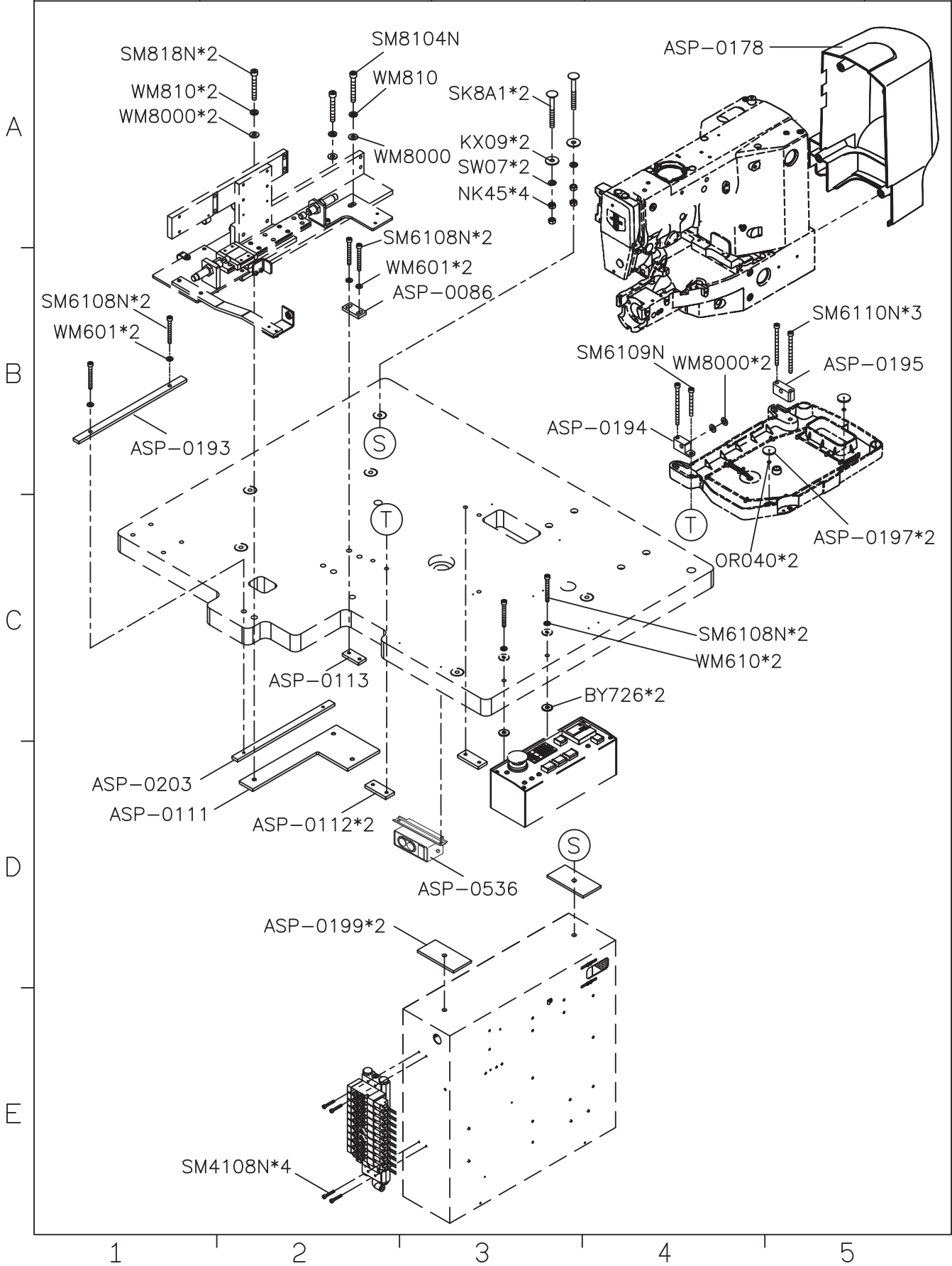

SIRUBA

PARTS LIST

Series

ASP-EBJ100S

Parts Group

ASP

Subclass Remark

Page

18/20

Date

2017/03/16

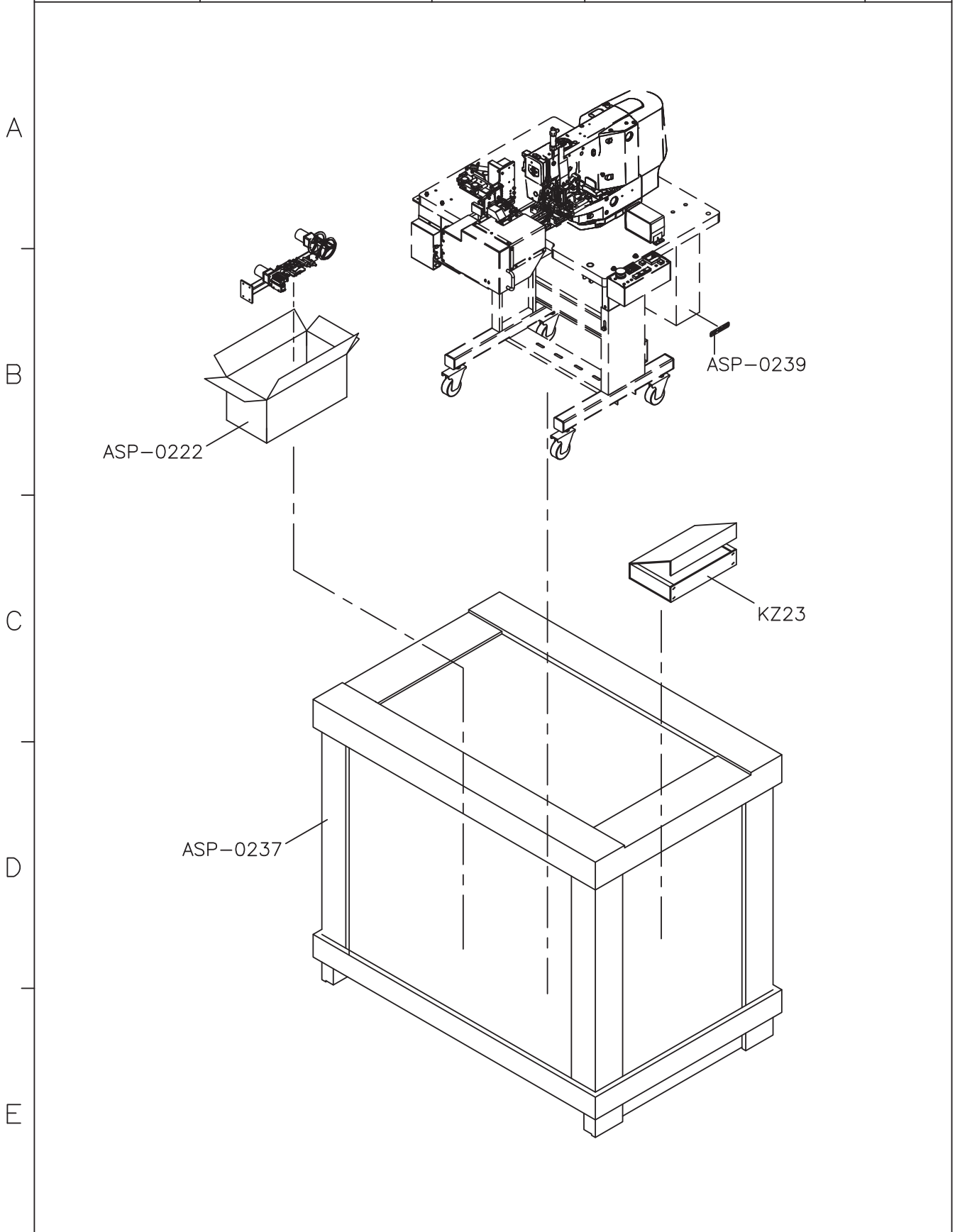

1

2

3

4

5

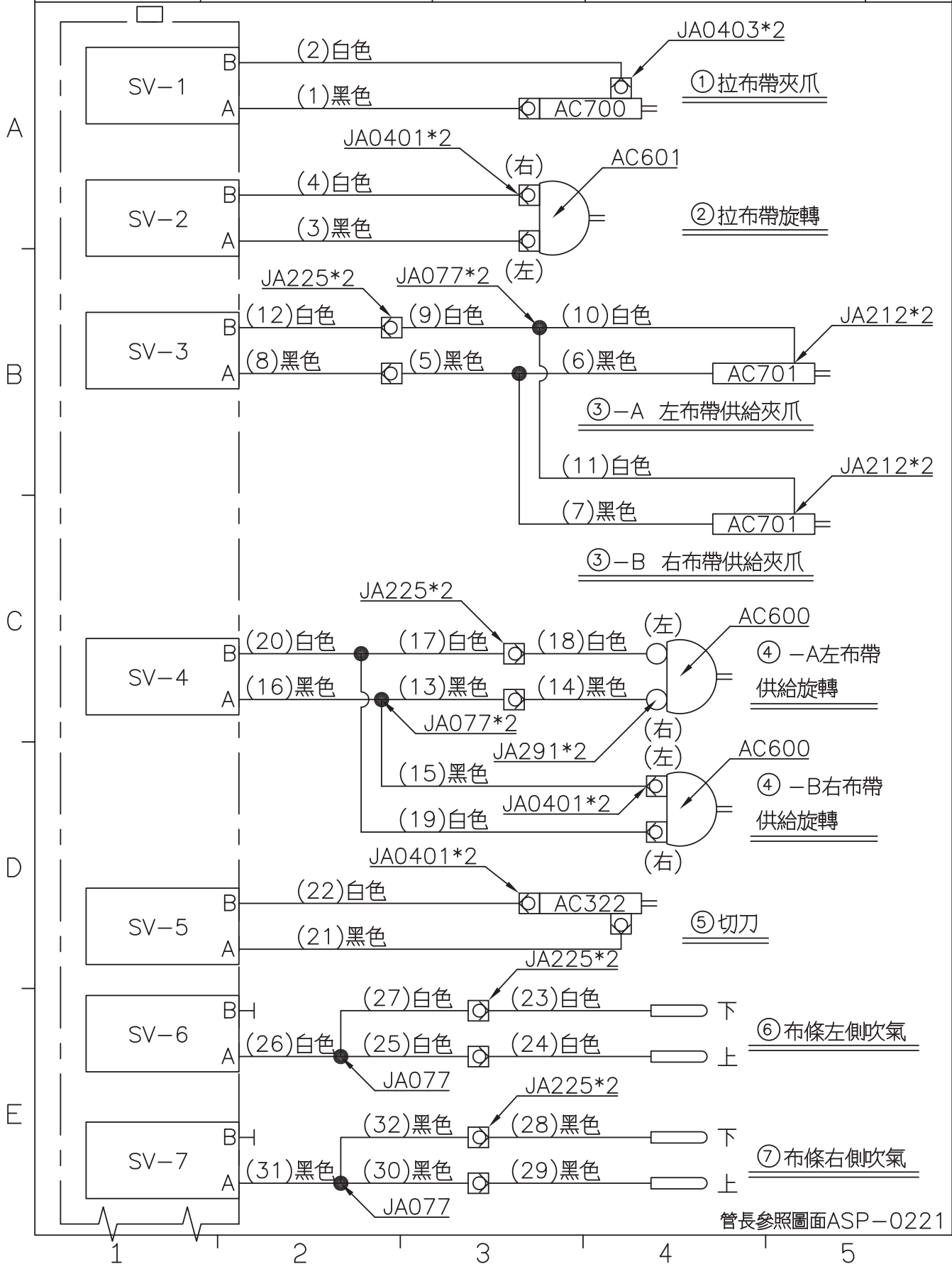

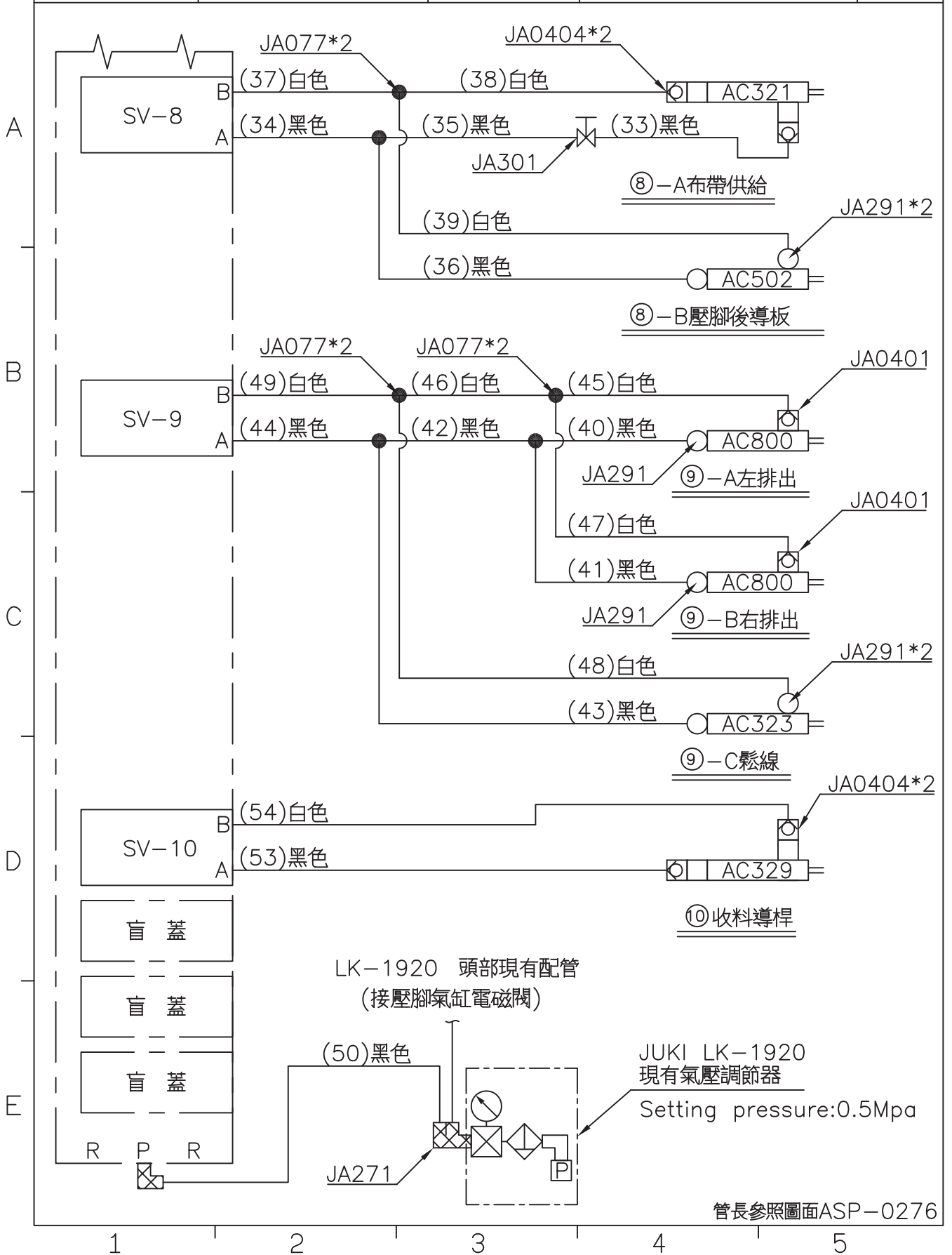

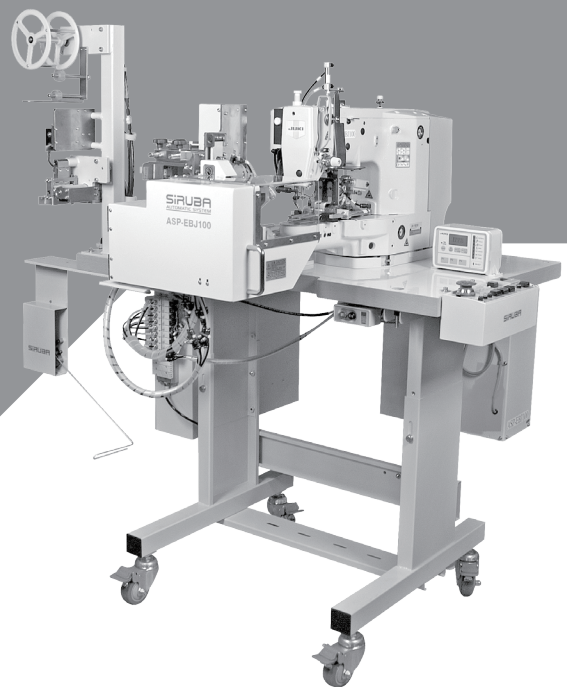

 **高林股份有限公司**
KAULIN MFG. CO., LTD.

由於對產品的改良及更新，本產品使用說明書中與零件圖之產品及外觀的修改恕不事先通知！
The specification and/or appearances of the equipment described in this instruction book & parts list are subject to change because of modification which will without previous notice.
ASP-EBJ100S.MAR.2017