

# SIRUBA

使用說明書與零件圖

INSTRUCTIONS BOOK & PARTS LIST

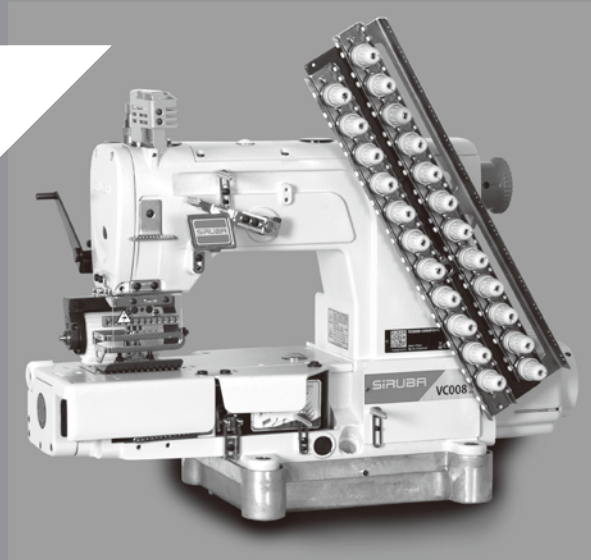

■ VC008B



CE



## 危險水準的說明 Explanation of Dangerous Level

 危險 Dangerous	<p>如果忽視此標記而運行了錯誤的機械操作，保養時肯定會引起當事者或第三者人員重傷或死亡。</p> <p>Don't ignore the warning sign and don't proceed incorrect operation. Or it will cause the person or the third party seriously injured or dead during maintenance.</p>
 注意 Caution	<p>如果忽視此標記而運行了錯誤的機械操作，保養時有可能會引起當事者或第三者人員受傷及造成設備損壞。</p> <p>Ignoring this warning sign and proceed incorrect operation will cause the person involved or the third party wounded and equipment damaged during maintenance.</p>

## 警告圖案表示及表示標誌的說明 Explanation of Warning Signs and Labels

警告圖案表示 Warning Sign		運動部位，謹防工傷事故 Moving part, beware of industrial accident
		高壓部位，謹防觸電事故 High voltage, beware of electric shock
		高溫部位，謹防燙傷事故 High temperature, beware of burns
指示標幟 Instruction Label		禁止 Prohibited
		地線的接線表示 Indication of ground wiring

索引	INDEX	頁 /PAGE
一般安全事項說明	GENERAL SAFETY INSTRUCTIONS	1
重要安全事項說明	IMPORTANT SAFETY INSTRUCTIONS	3
特別事項	WARNING	7
種類及規格說明	TYPES AND SPECIFICATIONS	8
機器如何安裝	HOW TO INSTALL THE MACHINE	11
潤滑油之注入與更換	FILL AND CHANGE THE LUBRICATION OIL	11
針之更換	CHANGE THE NEEDLE	13
穿線方法	THREADING	14
控線調整	THREAD CONTROL ADJUSTMENT	15
針高度之調整	ADJUST THE NEEDLE HEIGHT	16
護針片調整	ADJUST THE NEEDLE GUARD PLATE	16
針與勾針之調整	ADJUST THE NEEDLE AND THE LOOPER	17
勾針調整	ADJUST THE LOOPER	17
針與勾針之時位關係	TIMING POSITION OF THE NEEDLE AND THE LOOPER	18
撥線桿之固定	FASTEN THE THREAD WIPER	19
勾針與撥線桿之關係	THE RELATIONSHIP BETWEEN LOOPER AND THREAD WIPER	19
針、勾針與撥線桿之時位關係	TIMING POSITION AMONG NEEDLE, LOOPER, AND THE THREAD WIPER	20
勾針線控線桿之調整	ADJUST THE LOOPER THREAD CONTROL ROD	20
送具調整	ADJUST THE FEED DOG	21
送具平行調整	ADJUST THE FEED DOG'S PARALLEL	23
縫目之調整	ADJUST THE STITCH	23

後拉滾輪供給量之調整	ADJUST THE SUPPLEMENT OF THE REAR PULL WHEEL	24
上下滾輪間隙調整	ADJUST THE DISTANCE BETWEEN UPPER AND LOWER GEAR	24
桌板圖	TABLE CUT-OUT	27
零件圖	PARTS LIST	31
報廢流程	DEMOLITION PROCEDURE	54

## 一般安全事項說明

## GENERAL SAFETY INSTRUCTIONS

### 警告！

當使用這台機器，基本安全預防應恆被遵守，以減輕火災、電擊、或是個人傷害的風險。包含以下注意事項。  
在操作這台機器之前，請閱讀所有說明並且緊記於心。

- 1. 保持工作場所清潔**  
雜亂的環境與椅子會招引危害。
- 2. 考量工作場所環境**  
勿暴露電源於雨水之中、勿在溼氣重的地方或潮濕的場所使用機械器具。保持工作場所良好整齊。當有引發火災或爆炸危險時，勿使用電源工具。
- 3. 免於電擊危害**  
避免身體接觸地線或是接地表面。(即：管線，發熱物體，以及冷凍庫)
- 4. 勿使孩童接近**  
不要讓訪客接觸工具或是延伸管線。
- 5. 適當的穿著**  
不要穿著寬鬆衣物或是穿戴珠寶，這可能被活動零件拉扯而導致危險。穿戴護髮套可包住長髮。
- 6. 不要任意拉扯電線**  
絕不要用電源端拉扯機器，或是從插座猛拉電線來拔掉電線。使電線遠離熱源、油類或是尖銳邊緣。
- 7. 謹慎保養機器**  
遵從指示來添加潤滑油或是更換附件。定期檢測工具用線，如果有所損害，請使用合格的維修器具來修復。

### Warning!

When using this machine, basic safety Precautions should always be followed to reduce the risk of fire, electric shock and personal injury, including the followings. Read all these instructions before operating this product and save these instructions.

- 1. Keep work area clean**  
Cluttered areas and benches invite injuries.
- 2. Consider work area environment**  
Do not expose power to rain. Do not use machine tools in damp or wet locations. Keep work area well lit.  
Do not use power tools where there is risk to cause any fire or explosion.
- 3. Guard against electric shock**  
Avoid body contact with earthed or grounded surfaces (e.g. Pipes, radiators, ranges refrigerators.)
- 4. Keep children away**  
Do not let visitors touch the tool or extension code.
- 5. Dress properly**  
Do not wear loose clothing or jewelry, they can be caught in moving parts. Wear protecting hair covering to contain long hair.
- 6. Do not abuse the cord**  
Never carry the machine by cord or yank it to disconnect it from the socket. Keep the cord away from heat, oil, and sharp edges..
- 7. Maintain machine with care**  
Follow instructions for lubrication and changing accessories. Inspect tool cord periodically. If damaged, have it repaired by an authorized service facility.

## 8. 中斷機器電源

當不使用機器時、維修前、以及更換配件時。

## 9. 避免誤啟動

不要以手指置於啟動開關上之後，搬運一個已插入電源的工具。確定在插電之前，電源開關是關閉的。

## 10. 檢查損害零件

在進一步使用器具之前，應該小心檢查並確認損傷的零件或是穿戴保護器具來確認零件會正確運轉並且呈現應有功能。

## 11. 警告

除了在這本使用說明手冊中建議的功能之外，任何附件或是配件的使用，都可能會導致個人傷害的危險。

## 12. 由合格人員來修理器具

所以修理工作應由合格的人員使用原始個別零件來作修理。

## **連接電源的特別警示！**

1. 只可與有 "CE" 認證的按壓啟動裝置連接這台機器。
2. 遵守此使用說明手冊來安裝控制裝置。
3. 在操作過程中，永遠保持機器適當的接地。
4. 在調整、更換零件、或是維修保養之前，必須確定將插頭由插座拔出，以預防任何機器意料之外的啟動而造成危害。

## 8. Disconnect machine

When not in use, before servicing and when changing accessories.

## 9. Avoid unintentional starting

Do not carry a plug-in tool with a finger on the switch. Ensure the power switch is off when plugging in.

## 10. Check damaged parts

Before further use of the tool, a guard or other part that is damaged should be carefully checked to determine that it will operate properly and perform its intended function.

## 11. Warning

The use of any accessory or attachment, other than those recommended in this instruction manual, may present a risk of personal injury.

## 12. Have your tool repaired by a qualified person







Repairs should only be carried out by qualified persons using original spare parts.

## **SPECIAL WARNING FOR ELECTRIC CONNECTION!**

1. Incorporate this machine only with "CE" certificate hold-to-run control device.
2. Follow the instruction manual device to install control device.
3. Always earth machine appropriately during operation.
4. Before adjustment, parts change or servicing must be sure to pull out the plug from socket to prevent the hazard of unintentionally start of machine.







## 重要安全事項說明

恭喜您購買本機器，為了使這台機器能獲得最佳功能以及安全的操作，務必請正確的使用這台機器，使用前請仔細閱讀使用說明書，希望您能長期使用它。請記得將此說明書放在容易取得的地方。

-  1. 當您使用機器時，除了以下事項外，請注意其他基本安全措施。
-  2. 使用機器前，除了本使用說明書外，請詳細閱讀其他相關說明書。此外，請妥善保存此說明書，以便需要時可以隨時取閱。
-  3. 先確認機器是符合貴國安全規定及標準後，再使用機器。
-  4. 當機器完成操作時，所有安全配備必須安裝就緒，在缺少所述安全配備下操作是不被允許的，以免導致人員受傷。
-  5. 此機器應由受過適當訓練之操作員操作。
-  6. 為了安全，我們建議您配戴安全眼鏡。
-  7. 以下情形，請先關閉電源或拔掉插頭：
  - (1) 穿針線、導線片、天平等以及更換梭子時。
  - (2) 更換針、壓具、針板、送具、頂針片、車布導板，以及其他附屬配件時。
  - (3) 維修工作時。
  - (4) 離開工作場所或工作場所無人看顧時。

## IMPORTANT SAFETY INSTRUCTIONS

For operating safely and getting the best functions of this machine, you must operate it correctly. Please read and follow the instructions of this manual, and keep it at hand for future references. We are confident that you will enjoy this machine as much as we enjoy manufacturing it.



-  1. Instead of the following instructions, when you use this machine, please pay attention to the basic safety measures.
-  2. Before using this machine, please read this manual and all related instructions. In addition, please keep this manual for future needs.
-  3. Before using this machine, please ascertain that it conforms with safety standards and regulations of your country.
-  4. When the machine is ready for operation, all the safety equipments must be ready. Operate this machine without the specified safety devices is not allowed.
-  5. This machine must be operated by a properly trained operator.
-  6. For your own safety, we suggest you wearing goggles.
-  7. Please turn off the power switch or disconnect it for any one of the circumstances of the followings:
  - (1) When threading needle(s), adjusting thread Take-up(s), thread guide(s), and/or replacing bobbin(s).
  - (2) When replacing needles, presser feet, needle plates, feed dogs, needle guards, cloth guides and other parts or accessories.
  - (3) When repairing.
  - (4) When the operator leaves the working place or leaves the machine





- (5) 若使用離合器馬達而無煞車片裝置時，必須待馬達完全停止。

unattended.

- (5) If clutch motors without brake pads are used, must wait until the motor stops completely.

-  8. 假如不慎讓機器及配件使用之油或油脂，接觸到眼睛、皮膚或誤食時，請立刻以水清洗接觸部位及就診。  



-  8. If grease, oil, or any fluid contacts your skin or eyes by any chance, please wash the contacted area completely with clean water and consult a doctor. Or, swallow a ny fluid mistakenly, consult a doctor immediately.  



-  9. 請勿擅自碰觸運轉中之零件及配件及注意機器電源是否已開啟，以免導致人員受傷。

-  9. Do not touch any functioning parts and devices. Always attend to whether power switch is on or off before operating in order to prevent anyone from getting hurts.

-  10. 維修、修改及調整等工作，須由受過適當訓練的技師或熟手為之。維修時只許使用指定之零件。

-  10. Qualified technicians are required for adjustment, modification, and repair. Only use assigned parts for replacement.

-  11. 一般維修及檢查工作必須由受過適當訓練的人員為之。

-  11. Routine maintenance and service must be performed by well trained persons, or qualified technicians.

-  12. 電子零件維修及保養工作必須由資深的電子技師為之，或由非常熟練的人員檢查及指導，當發現零件損壞時，請立刻停止機器運轉。

-  12. Maintain and check the electronic parts must be done by qualified electrician or well-trained persons. If any electronic part damaged or malfunctioned, stop the machine immediately.

-  13. 在做裝有氣動式零件（例如氣缸）機器的維修及保養工作前，機器連接空壓機及高壓空氣必須予以關閉及卸除，機器中殘存高壓氣體必須予以消除，此外調整及性能檢查只能由受過適當訓練的技師或熟手為之。

-  13. The air house has to be detached from the machine and the compressor or air supply has to be cut off before repairing and servicing the machine equipped with pneumatic parts such as an air cylinder. Qualified technicians or well-trained persons are required for adjustment and repairs.

-  14. 機器使用一段時間，必須定期清理。

-  14. To ensure the best performance, periodically clean the machine is necessary.

 15. 為使機器能正常操作以及減少噪音，機台務必平放地上，機器避免在強烈噪音的環境下操作。

 16. 選用適當的電源插頭，並由電子技師將其安裝在機器上，且插頭必須插在接地線之插座上。

 17. 機器只允許被使用於指定用途上，其他用途是不允許的。

 18. 修改或變更機器必須依照安全規定及標準，同時採取有效的安全措施或變更機器所引起損壞之責。

19. 警告提示以兩種符號標示：

 (1) 對操作員或服務人員之傷害危險，也為了避免觸電之危險，請勿打開馬達電器箱之外蓋，也不要觸摸電器箱裡面之零件。

 (2) 必須特別注意事項

- 絕對不可在移動外蓋，手指保護蓋或安全配件後，進行機器操作，以免導致人員受傷。
- 為了避免被機器纏住，當機器運轉中，您的手、頭髮及衣服，需遠離手輪；此外這些部位周圍不可放置任何物品，以免導致人員受傷。

 15. In order to operate properly and to reduce the noise, please place the machine flat and level on the ground. Avoid operating the sewing machine at a noisy surrounding.

 16. Select a proper power plug and install it by an electrician. Please connect the power plug to a grounded receptacle.

 17. This machine can only be used for the designed purpose. Other uses of this machine are not allowed.

 18. Any modification or conversion made on this machine must be conformed with the safety standards and regulations. Precaution is necessary. No responsibility will our company take for damages caused by any modification or conversion of this machine without permission.

19. Two safety warning signs are applied as warning signs:

 (1) For the safety of operators and service persons, please don't open the cover of any electronic control boxes of motor or other devices and don't touch any components inside to avoid electrical shock hazards.

 (2) Always keep in mind:

- Please never operate this machine without outer cover, finger guard or any safety device to avoid physical injury.
- Please keep your hair, fingers and clothes away from the hand wheel while the machine is in operation, as well as never put anything near these parts, to prevent the risk of injuries by tangled into them.

 c. 當您打開電源開關後或機器已在運轉中，絕不可將您的手放在針的下方或針線控線桿外蓋中，以免導致人員受傷。

 d. 當機器運轉中，梭頭高速轉動，為了避免對手可能引起之傷害，必須確定您的手保持遠離梭頭附近。此外，當更換梭子時，確定電源開關已關閉，以免導致人員受傷。

 e. 當放置或抬起機器時，小心勿將手置於機器中，以免導致人員受傷。

 f. 為了避免機器突然啟動而引起可能意外，當機頭傾斜時，請關掉機器電源，以免導致人員受傷。

 g. 如果您的機器是配置伺服馬達，機器於靜止狀態時，馬達是不會產生噪音的，為了避免機器突然啟動而引起可能意外，故請關掉機器電源。

 h. 為了避免觸電之危險，請絕不要在移開電源接地線後操作機器。

 i. 為了避免觸電或電子零件損壞而引起之可能意外，請先切斷電源，再插上或拔掉插頭。

 c. Please never put your fingers under the needle(s) or in the thread take-up cover to prevent physical injuries when you turn on the power switch or operate the machine.

 d. While the machine is in operation, the hook rotates at a high speed. Please keep your hands away from the area of hook to prevent any potential injury to your hands. In addition, please make sure to turn off the power of the machine while changing bobbins.

 e. Be careful and do not place your fingers inside the machine when placing or lifting the machine head to avoid possible physical injuries.

 f. Please turn off the power before tilting the machine head to avoid possible accidents due to abrupt start of this machine.

 g. For machine equipped servo motors, the motors do not produce noise while the machines are at rest. Therefore, please turn off the power of this accidents due to abrupt start of the machine.







 h. Never operate the sewing machine after the ground wire is removed to avoid electrical shock hazards.

 i. Please turn the power switch off before connecting or disconnecting the power plug to prevent possible accidents due to electric shock or damaged electronic components.

## 特別事項

## WARNING

為了避免機器故障及損壞，請先確定以下事項：







-  1. 當您安裝好機器後，做第一次機器操作前，請徹底清潔機器。
-  2. 清除運送途中累積之灰塵及溢出之油脂。
-  3. 確定電壓及馬達相數（單相或三相）安裝正確。
-  4. 確定電源插頭正確地接上電源。
-  5. 當使用電壓與標示電壓不同時，請勿使用機器。
-  6. 確定機器轉動方向是否正確。



警告：

在操作或調整本書中所提到之各步驟前，請先將電源關掉，以免因為機器突然啟動造成之意外。

Please confirm the followings to avoid malfunction or damage to this machine.

-  1. After installing the machine, and before the first operation, please clean it completely.
-  2. Clean all dust and overflowed oil during transportation.
-  3. Confirm that the voltage and the phase (single or 3 phase) of motor are set correctly.
-  4. Confirm that the power plug is correctly connected to the power supply.
-  5. Never use the machine when the local voltage type is different from the marked voltage on the nametag attached on the machine.
-  6. Confirm that the rotating direction of the machine pulley is correct.



Warning:

Before doing any operation or any adjustment described later in this manual, please turn the power off to prevent accidents caused by abrupt start of the sewing machine.

## 種類及規格說明

## TYPES AND SPECIFICATIONS

### 1. 型號分類表示：

VC008 B - 04 064 P / VAD  
 (1) (2) (3) (4) (6) (7)

VC008 B - 04 48-191 P  
 (1) (2) (3) (5) (6)

(1) 高速多針雙重鏈式環縫車

(1) High speed cylinder bed looper in line with feed multineedle double chainstitch machine with puler.

(2) B：皮帶式傳動

(2) B：Belt-Drive

(3) 表示針數：04(針)、06(針)、08(針)、11(針)、12(針)

(3) Indicate the number of the needle: 04(4 needles), 06(6 needles), 08(8 needles), 11(11 needles), 12(12 needles).

(4) 針之針幅(等距)(圖1/表1)

(4) Interspace of needles (equal space). (Fig.1 / Table.1)



圖 1/ Fig.1

型式 Types	A	總針寬(C) Total Width
04064	1/4"(6.4 mm)	3/4"
04085	1/3"(8.5 mm)	1"
04095	3/8"(9.5 mm)	1 1/8"
04106	5/12"(10.6 mm)	1 1/4"
04127	1/2"(12.7 mm)	1 1/2"
12048	3/16"(4.8 mm)	2 1/16"
12064	1/4"(6.4 mm)	2 3/4"

表 1/ Table.1

(5) 針之針幅 ( 不等距 ) ( 圖 2 / 表 2 )

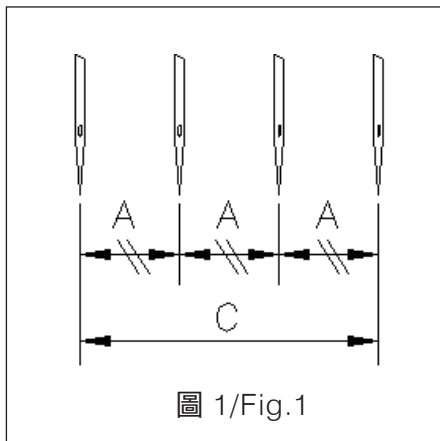
(5) Interspace of needles (unequal space)  
(Fig.2 / Table.2)

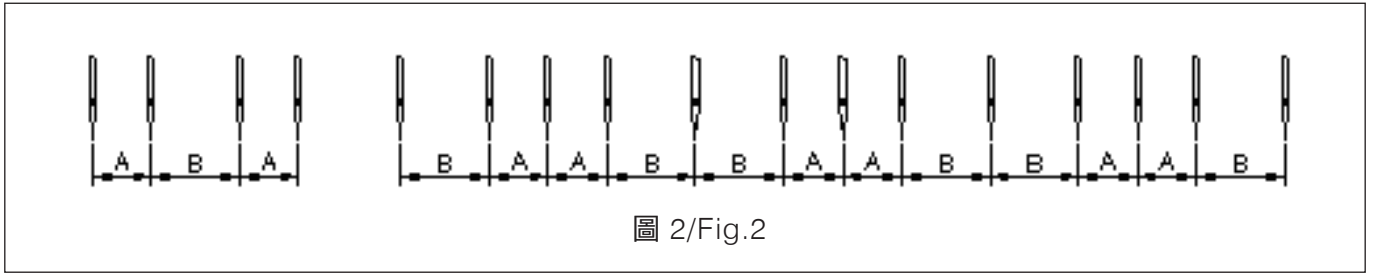

形式 Types	A - B - A	總針寬 (C) Total Width
0448 - 191	3/16" - 3/4" - 3/16"	1 1/8"
0448 - 222	3/16" - 7/8" - 3/16"	1 1/4"
0448 - 254	3/16" - 1" - 3/16"	1 3/8"
0464 - 191	1/4" - 3/4" - 1/4"	1 1/4"
0464 - 127	1/4" - 1/2" - 1/4"	1"
0464 - 254	1/4" - 1" - 1/4"	1 1/2"

表 2 / Table.2

[1] 最內兩針之針幅尺寸如表 2 之 B 欄位顯示。

[1] The interspace from center to center of the two center needles is shown as B in Table.2

[2] 若針幅為等距，則此欄不顯示。

[2] For equal distance of each needle the length will not show in this table.

[3] A 之尺寸，標示於表 1 之欄內。

[3] The length of A are shown in Table1.

(6) 備有標準後拉滾輪機構。

(6) Equipped with standard rear pullers.

(7) 輔助配件：

(7) Indicates the accessory:

編號	用途	Application
VAD	氣壓式抬壓腳裝置	Pneumatic Presser Foot Lifter
VAR	密縫裝置	Condense Stitching Device
VCE	環型褲頭鬆緊帶上帶裝置	Tubular Elastic Inserting and Attaching
VPL	貼帶裝置	Tape Attaching
VPS	伸縮線抽摺縫裝置	Elastic Thread Shirring
VUT	自動切線裝置	Pneumatic Automatic Thread Trimmer
VSF	門襟車縫裝置	Shirt-Fronting
FH	下固定式送帶盤	Lower Fixed Tape Holder
LSA	上固定式送帶盤	Upper Fixed Tape Holder
RL	筒式衣物撐開滾輪組	Tubular Extending Roller

表 3/Table.3

## 2. 規格

(1) 線跡形式：雙環縫式多針縫

(2) 針數：4~12

(3) 線數：8~24

(4) 使用針：UOX113#11~#18、  
DVX57#11~#18、DV-K25#18~#21

(5) 使用線：S P 線 (2 股 40 絲)

(6) 勾針數：4~12 組

(7) 針幅：如上頁說明

(8) 針棒行程：34mm

(9) 縫目範圍：每吋 (25.4mm)6~24 針，扣壓可調式

(10) 最高縫速：4000rpm

(11) 給油方式：全自動給油潤滑

(12) 潤滑油：Agip#32、Mobil#10 或 Esso#32

(13) 安裝：上乘式或半沉式

## 2. Specifications

(1) Stitch type: multi-needle double chainstitch sewing.

(2) Number of needle: 4~12 needles.

(3) Number of thread: 8~24 threads.

(4) Needle to be used: UOX113#11~#18,  
DVX57#11~#18, DV-K25#18~#21.

(5) Thread to be used: S P thread (2 ply 40 count)

(6) Number of looper: 4~12 sets.

(7) Distance between needles:  
as previous page.

(8) Needle bar stroke: 34mm.

(9) Stitch length: 6~24 gauge per  
inch (25.4mm), adjustable by knob.

(10) Swing speed: MAX 4000 R.P.M

(11) Lubrication: Auto-lubrication style.

(12) Lubrication oil: Agip#32, Mobil#10 or  
Esso#32

(13) Installation: non-merged or submerged.

## 機器如何安裝

1. 依本機器所附桌板裁製圖及零件組合圖所列之配件，依序安裝防震基座及線架。(如圖 3、圖 4 所示)



圖 3/Fig.3

注意：

- (1) 桌板厚度約為 45 mm。
- (2) 馬達規格：直驅馬達，單相 4 極 600 瓦特。

## HOW TO INSTALL THE MACHINE

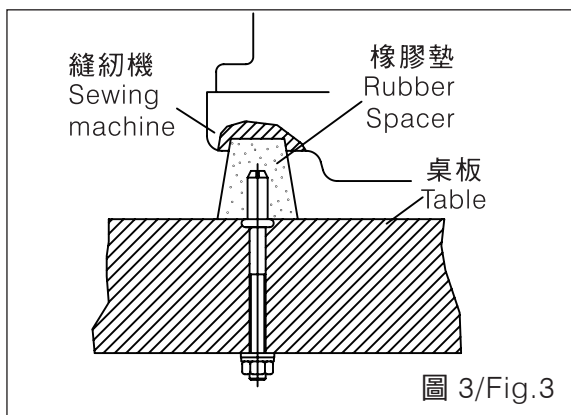
1. Use the accessories of the machine one by one to install the anti-shock seat and thread stand as the attached table cut-out and the parts list showed. (Fig.3 , Fig.4)



圖 4/Fig.4

NOTE :

- (1) Table thickness is about 45 mm.
- (2) The specification of the motor: direct drive motor, 1 phase, 4 poles, 600 W.

## 潤滑油之注入與更換

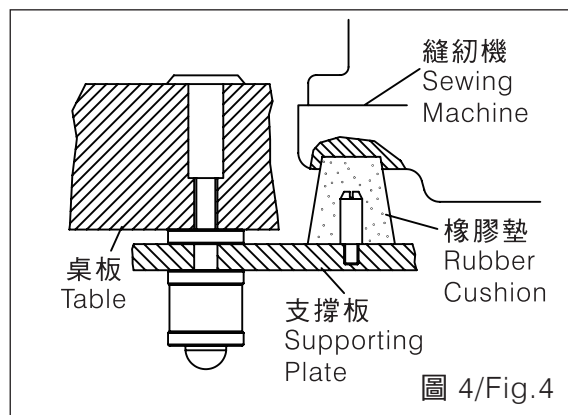
新機器運裝前均已將油倒盡，因此機器使用前必須加入潤滑油。

1. 潤滑油之注入 (圖 5):  
\* 將 A 旋開，以包裝箱內所附之超高速潤滑油或選用 MOBIL#10 或 ESSO#32 等級之潤滑油加入，使油窗 C 位於上油標線即可，然後再裝上 A。

## FILL AND CHANGE THE LUBRICATION OIL

The oil is empty in each new machine before shipping. Therefore, it is necessary to fill the lubrication oil before using.

1. Fill the lubrication oil (Fig.5)  
\* Rotate & open cover A, and lubricated with high-speed oil, or the same level oil such as Mobil#10 or ESSO#32. The oil must reach up oil line in oil tank window, then close cover A again.





圖 5/ Fig.5

## 2. 潤滑油之更換 (圖 6)

- \* 將卸油孔處旋鈕旋開，使油槽之油完全排出後再鎖緊。
- \* 為延長本機器之壽命，請於開始使用四個星期後更換新油，爾後約每四個月更換一次。

## 2. Change the lubrication oil (Fig.6)

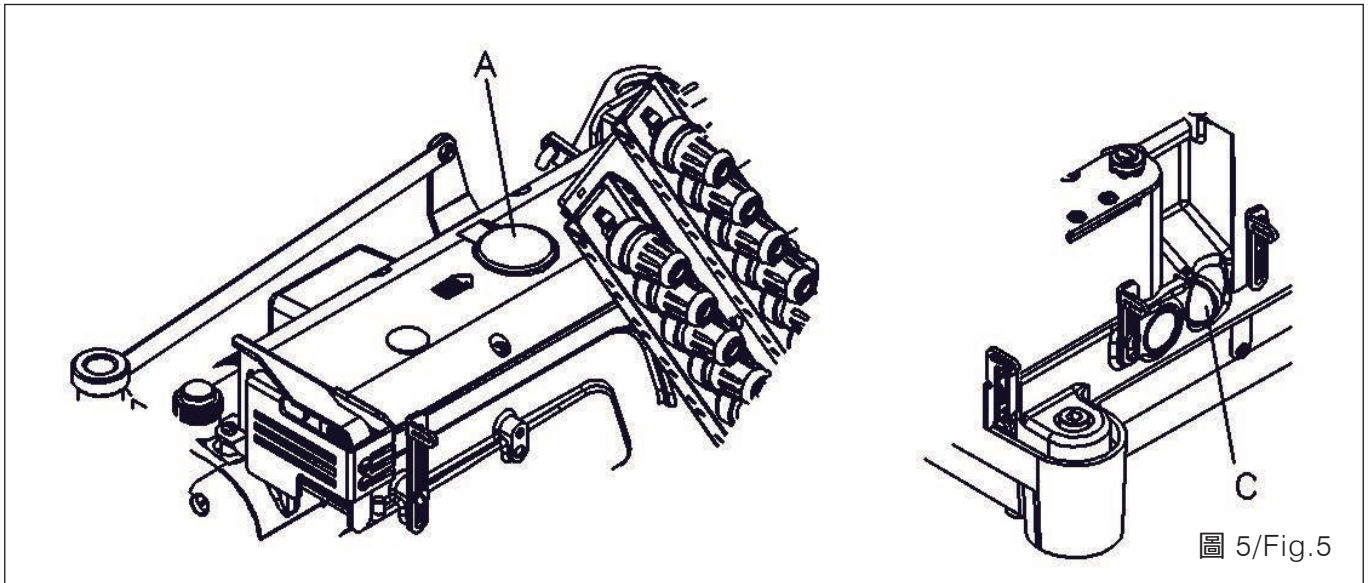
- \* Loosen oil screw and re-lock it after the oil in the oil tank has emptied.
- \* For extending the term of use, please change the oil after 4 weeks after first use. Then, change the lubrication oil every 4 months.

## 3. 濾油器之更換 (圖 7)

- \* 本機器特別裝有濾油器，約每使用一個月後應卸下清洗，必要時得更換新品。

## 3. Change the oil filter (Fig.7)

- \* This model has equipped an oil filter especially. This filter should be cleaned every one month, and should change a new one if necessary.



圖 6/ Fig.6



圖 7/ Fig.7

定期加潤滑油，周期為一星期。(需按時加油的孔)(圖 8、圖 9)

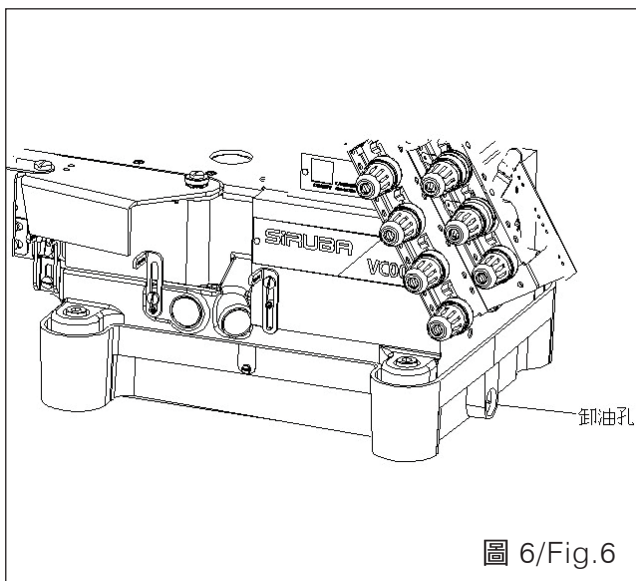
Add the lubrication regularly;the cycle is one week.(The holes needed to be added the oil. )(Fig.8,Fig.9)

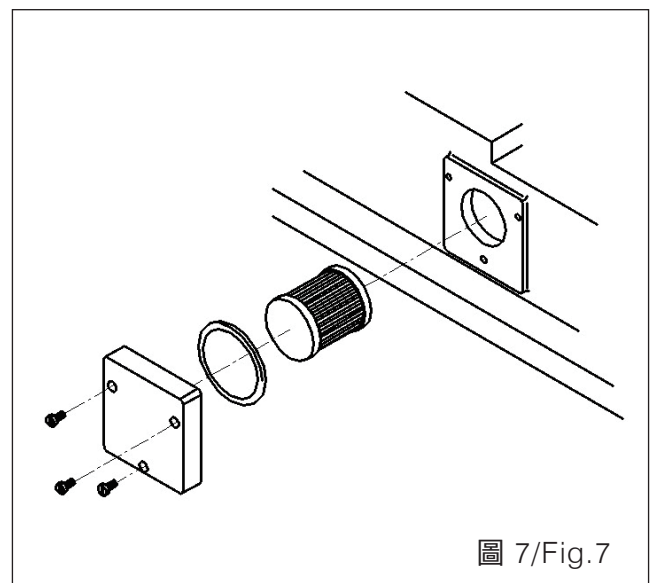

圖 8/Fig.8



圖 9/Fig.9

## 針之更換

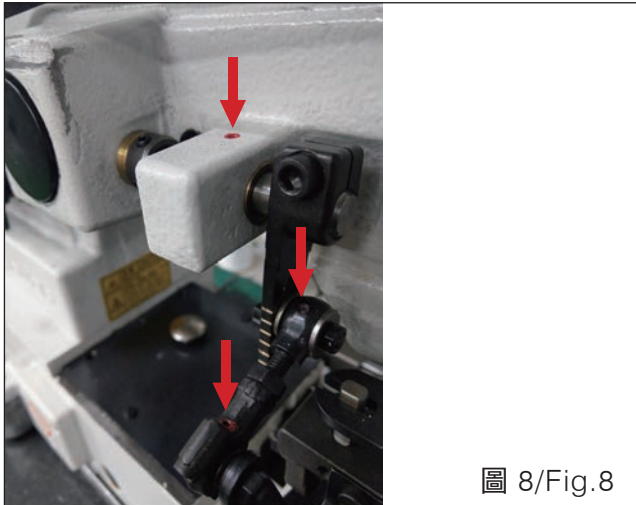
## CHANGE THE NEEDLE

\* 選用針之規格與尺寸請參照表4。

\* Please refer Table.4 to know the specifications and the sizes of the needles.

針的規格系統 NEEDLE SYSTEM	針的尺寸 NEEDLE SIZE
UOX113	#11 ~ #18
DVX57	#11 ~ #18
DV-K25	#18 ~ #21

表 4/Table.4

\* 旋開螺絲 A 並取下針。(圖 10)

\* Loosen screw A and take off the needle.(Fig.10)

\* 將新針插入針座之針孔最底端，並使針之凹槽向著自己。

\* Insert the new needle into the needle hole of the needle seat until the needle reaches to the bottom.In addition,turn the needle to have the groove on the needle facing you.

\* 如果車針安裝不正確，不但會引起跳針、斷線，還會損壞勾針，務必注意。

\* If installed the needle incorrectly,it will cause skipped stitches, broken threads,and will break the needle.Please be very careful about this.

\* 重新鎖緊螺絲 A。

\* Retighten the screw A.



圖 10/ Fig.10

穿線方法

THREADING

1. 請確實按照圖示作好針之穿線，錯誤之穿線將引起斷線，跳針或車縫不平坦等現象。(圖 11)

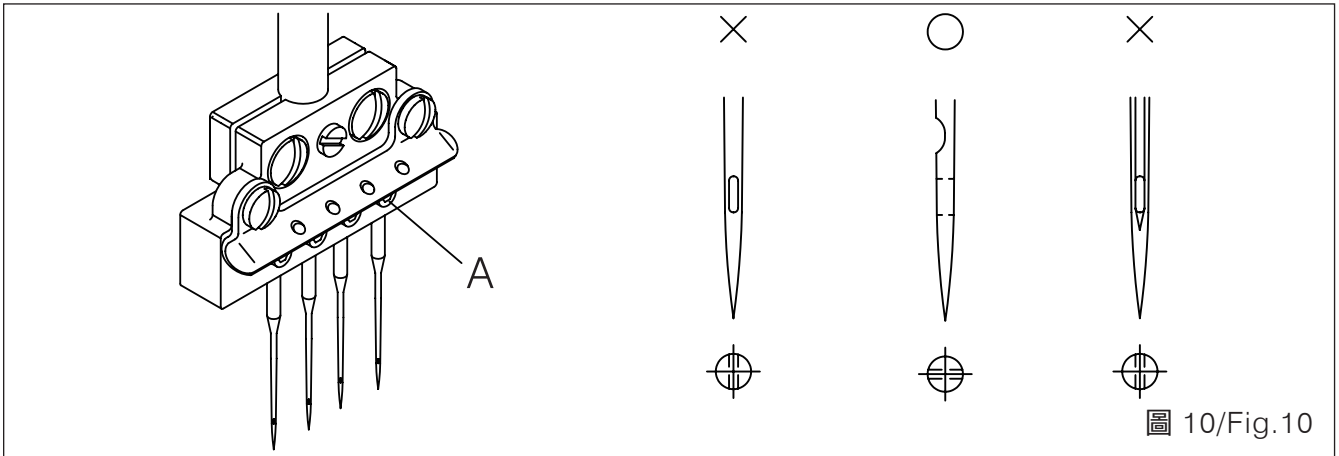
1. Please thread as the figure illustrated, otherwise, it may cause thread-broken, skipped stitches, or uneven stitches. (Fig. 11)



圖 11/ Fig.11

2. 在穿勾針線時，應將勾針座引出軸 P 沿箭頭方向拉出使勾針座向前彈出，然後進行穿線。(圖 12)

2. When threading, the leading shaft of the looper holder should be pulled out as the arrow direction, so that the looper holder will slightly move forward. Then, proceed threading. (Fig.12)

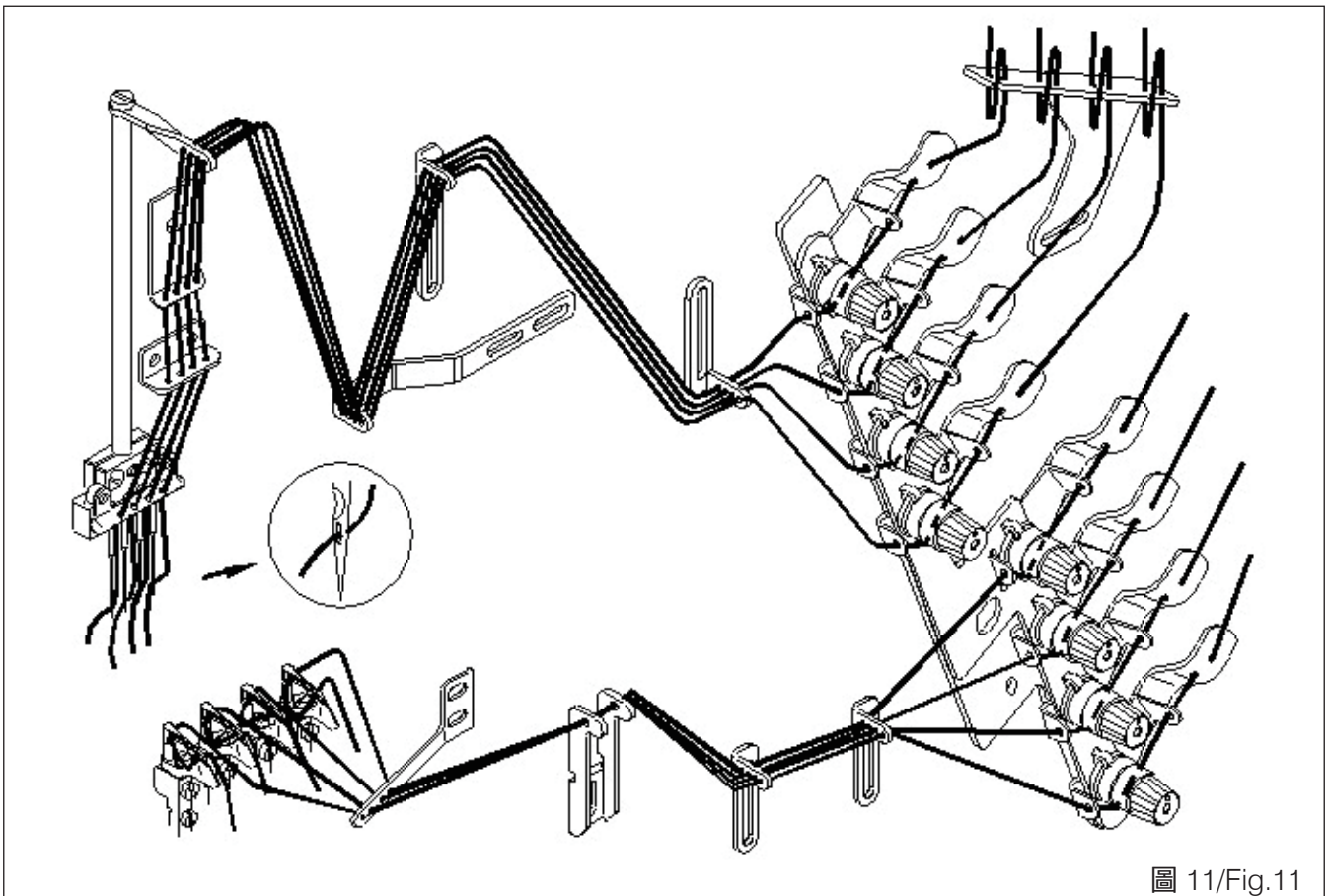

圖 12/ Fig.12

## 控線調整

## THREAD CONTROL ADJUSTMENT

控線強弱必須根據車縫布料層數線的種類與車縫的針距等不同而做不同之調整。(圖 11)

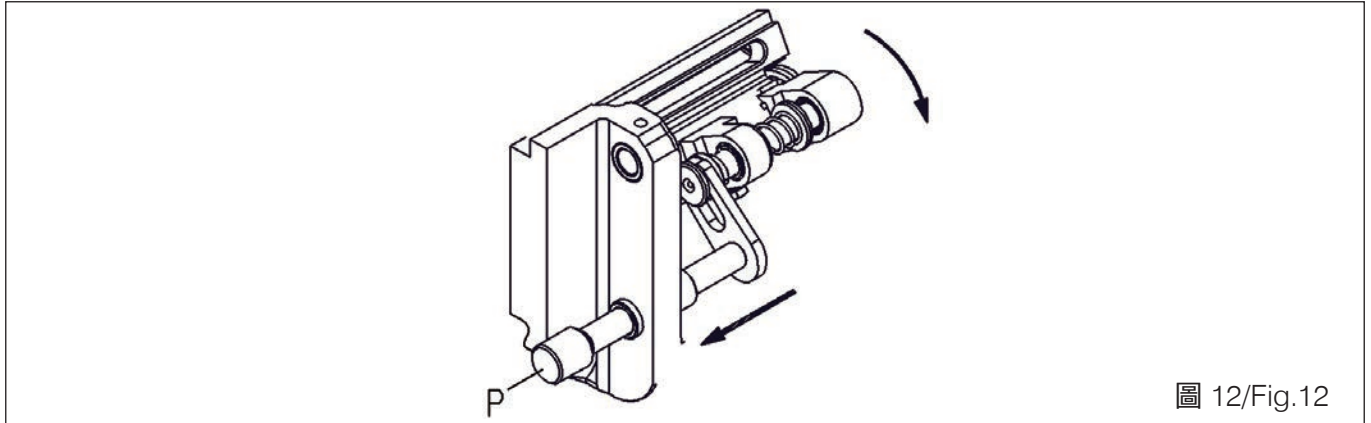
The thread tension strength should be adjusted differently according to the fabric, the layers amount of the sewing fabric, and the stitch length. (Fig.11)

\* 將控線鈕順時針方向旋轉時，線越緊，反之則越鬆。

\* Rotate the thread control knob clockwise, and the thread tension will be tighter. Otherwise, the tension will be looser.

針控線桿之調整 (圖 13)

Adjust the needle thread control rod (Fig.13)

\* 針線控線桿 B 依縫線使用種類來選擇使用之狀態，放鬆螺絲 A 將 B 上下移動調整，在使用伸展性大的縫線時將 B 上移，反之下移。

\* Based on thread types to adjust the needle thread control rod B to the best using status. Loosen screw A to move B up or down to adjust. Move B upward when using high extensibility thread. Otherwise, move B downward when using low extensibility thread.



圖 13/ Fig.13

## 針高度之調整

## ADJUST THE NEEDLE HEIGHT

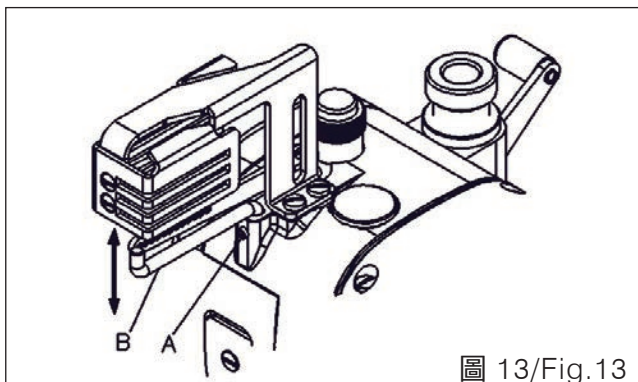
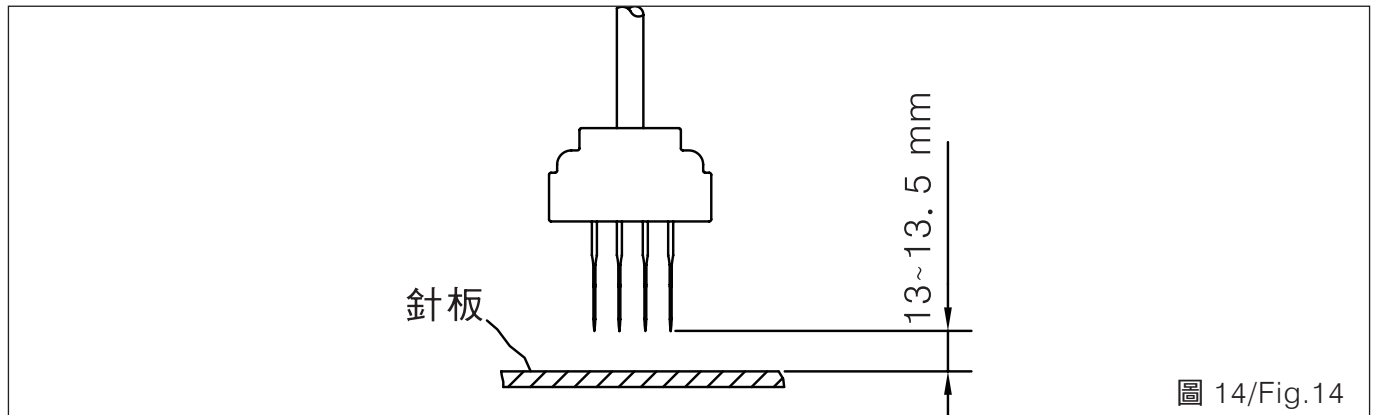

\* 當針棒上升至上始點時，調整針尖與針板面之距離為 13~13.5mm(圖 14)

\* When the needle bar rises to the upper dead point, adjust the distance from pinpoint to the surface of the needle plate to be 13~13.5mm. (Fig.14)

\* 打開上方之側蓋橡膠塞A，並鬆開螺絲B，上下調整針棒之高度後再固定之。(圖 15)

\* Open the rubber plug A of side cover on the top, and loosen screw B. Then fix it after adjust the height of the needle bar up and down. (Fig.15)

注意：經過調整後，必須確定每一根針是通過針板的針孔中央。(圖 16)

Note: Make sure that every needle is through the central of the needle hole of the needle plate after adjustment. (Fig.16)

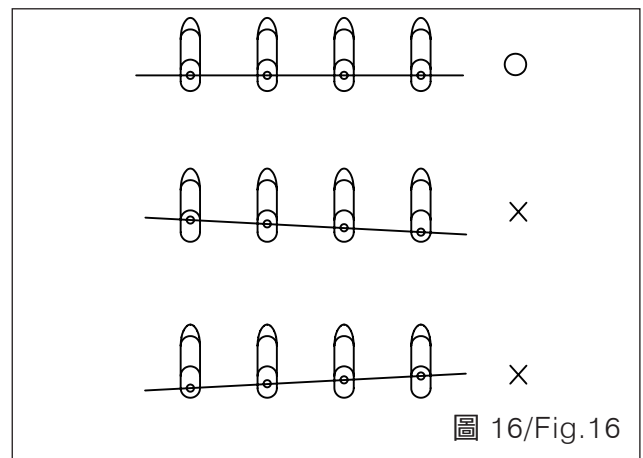
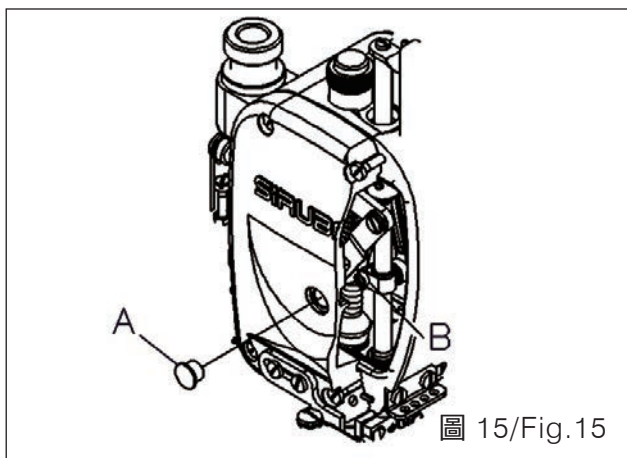

## 護針片調整

## ADJUST THE NEEDLE GUARD PLATE

放鬆螺絲A，調整護針片，使其與針之間隙為 0~0.1 mm (圖 17) 後，再鎖緊螺絲A。

Loosen screw A, and adjust the distance from the needle guard plate to the need to be 0~0.1 mm. Then, tighten the screw A. (Fig.17)



圖 17/ Fig.17

## 針與勾針之調整

1. 將勾針完全插入勾針座內稍微鎖緊螺絲 A。  
(圖 18)
2. 轉動皮帶輪使針上升，並使勾針前進至左側中心線。(圖 19)
3. 調整勾針尖與針側之間隙為 $0\sim 0.05\text{mm}$ 。
4. 再鎖緊螺絲 A。

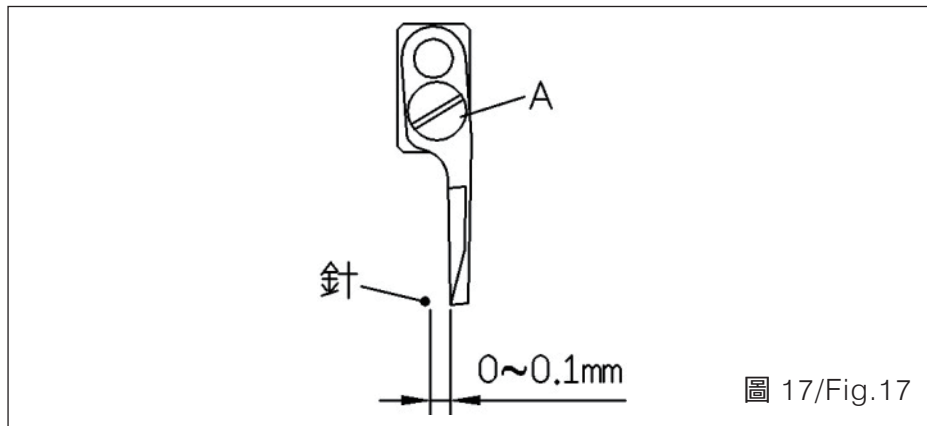

圖 18/ Fig.18

## ADJUST THE NEEDLE AND THE LOOPER

1. Insert the looper into the looper holder completely, and tighten the screw A a little. (Fig.18)
2. Turn the belt pulley to raise the needle and to move the looper forward to the left central line of the needle. (Fig.19)
3. Adjust the looper so that the distance between the looper top and the needle side is  $0\sim 0.05\text{ mm}$ .
4. Retighten the screw A.

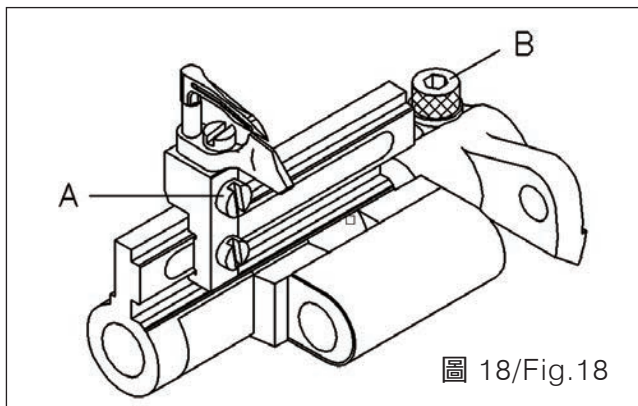

圖 19/ Fig.19

## 勾針調整

當針位於下始點時，勾針尖端與針中心線之間隙為  $2.8\text{mm}$ 。(圖 20)

調整時將勾針底座驅動桿固定螺絲 B 放鬆，前後調整勾針座後再鎖緊螺絲 B。(圖 18)

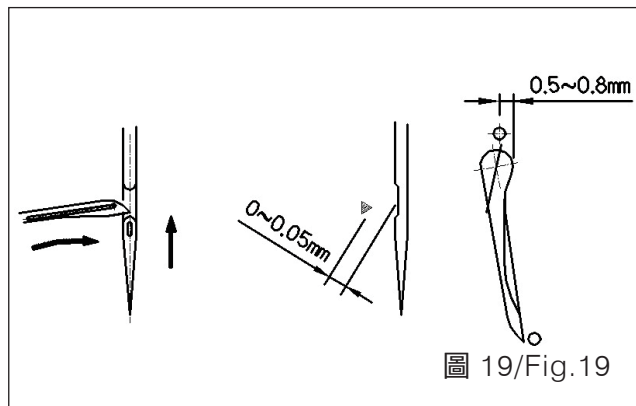
## ADJUST THE LOOPER

When the needle locates at the lower dead point, the distance from the looper top to the central line of the needle is  $2.8\text{ mm}$ . (Fig. 20)  
For the adjustment, please loosen the fixed screw B of the drive rod of the looper seat, adjust the looper seat back and forth, and then retighten the screw B. (Fig. 18)



圖 20/Fig.20

## 針與勾針之時位關係

當針由下始點開始往上移，且勾針由後始點往前移至如 (圖 21)A 所示之位置時。勾針尖與針孔上方之距離為 1.5mm。

當針由上始點開始往下移，且勾針由前始點往後移至如 (圖 21)B 所示位置時，勾針尖與針孔上方之距離為 3mm，以上即為正確之關係位置，即勾針在針中心位置往回時，差 1.5mm。

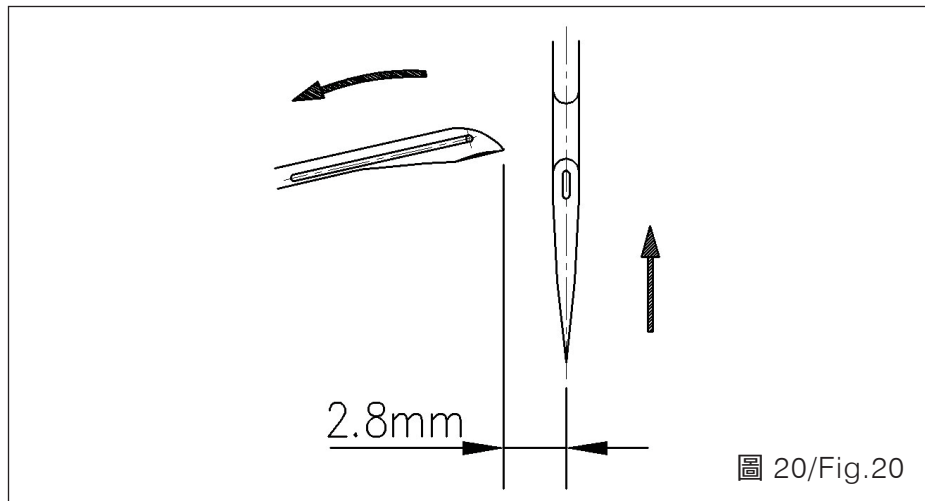
調整時，將偏心凸輪 A 的固定螺絲 B 放鬆，前後調整即可調整期間之時位關係。(圖 22)



圖 21/Fig.21

## TIMING POSITION OF THE NEEDLE AND THE LOOPER

When the needle starts moving up from the lower dead point, and the looper starts moving forward from the rear dead point to the position A shown as the Fig.21, the distance from the looper top to the upper point of the needle hole is 1.5mm.

When the needle moves down, and the looper moves backward from the front to the position B shown as Fig.21, the distance from the looper to the upper point of the needle hole is 3 mm. That is the correct relationship position, which means the looper is 1.5 mm away from the needle central position.

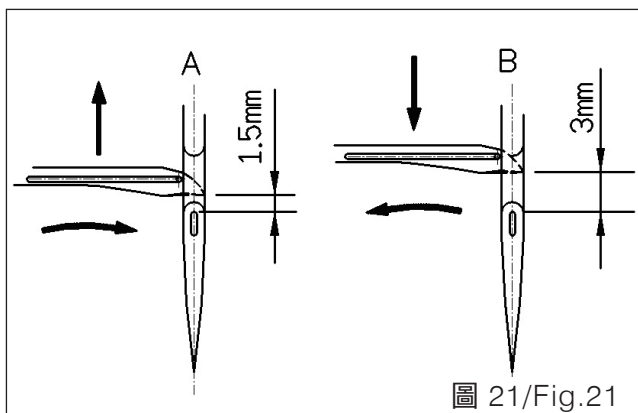
While adjusting, loosen the fixed screw B of the eccentric A and move the eccentric A back and forth to adjust the time correlation position. (Fig.22)



圖 22/Fig.22

## 撥線桿之固定

撥線桿 A 與車針之間隙如 (圖 23)。

當針棒於下方位置時，將撥線桿 A 固定螺絲 B (圖 24) 放鬆調整至 (圖 23) 所示之尺寸，並注意各桿之平行，再鎖緊。

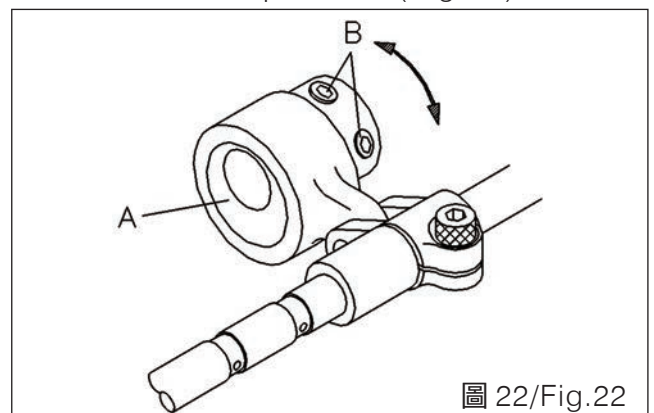
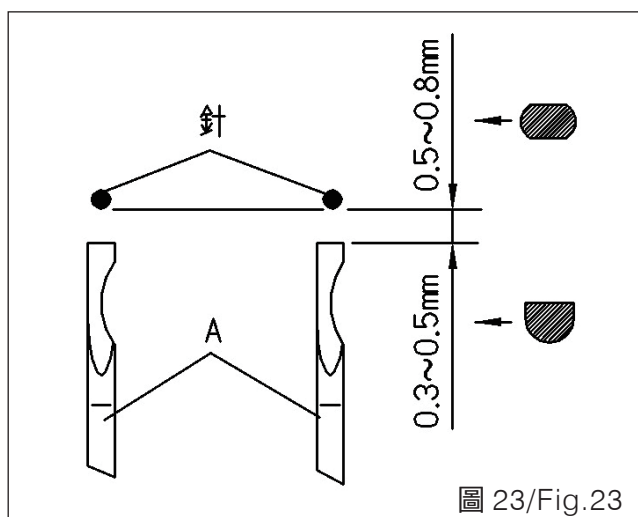

## FASTEN THE THREAD WIPER

The distance between the thread wiper A and the needle refer to (Fig.23).

When the needle locates at lower position, loosen the fixed screw B on the thread wiper A (Fig.24), adjust the wiper to the size show as (Fig.23). Be careful of the parallel of each wiper, and then retighten the screw B.

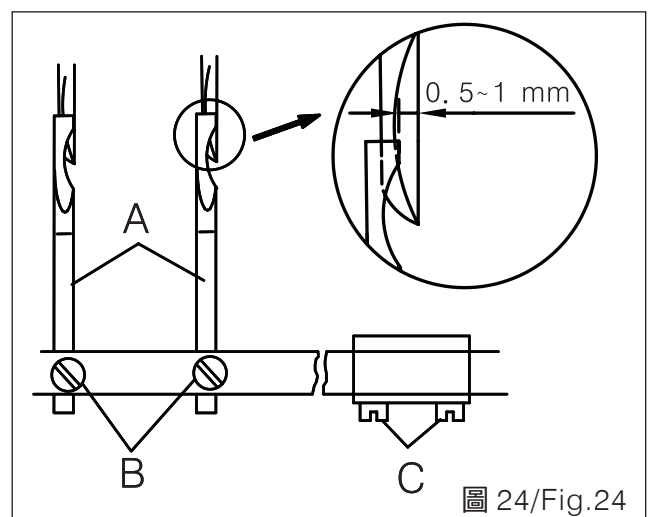

## 勾針與撥線桿之關係

當撥線桿 A 於左始點位置時，撥線桿 A 右端與勾針右端二者之間隙為 0.5~1mm。(圖 24) 而勾針與撥線桿 A 之間隙為 0~0.1mm。(圖 25)

調整時：

1. 先放鬆再稍鎖緊撥線桿心軸固定螺絲 C。(圖 24)
2. 旋轉皮帶輪使撥線桿心軸連桿移到左始點。
3. 調整使符合上述條件，再鎖緊螺絲 C。

## THE RELATIONSHIP BETWEEN LOOPER AND THREAD WIPER

When the thread wiper A is at the left dead point, the distance from the right side of the thread wiper A to the right side of the looper is 0.5~1mm (Fig.24). As well as it is 0~0.1 mm from the looper to the thread wiper A (Fig.25).

When adjusting:

1. Loosen the fixed screw C of the thread wiper main shaft, and then retighten it a little. (Fig.24)
2. Turn the belt wheel to move the thread wiper main shaft connecting rod to the left dead point.
3. Adjust the device to match the conditions describing above and relock screw C.



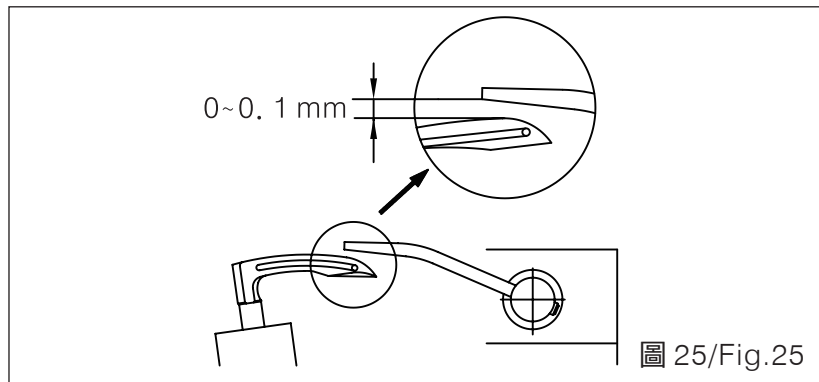

### 針、勾針與撥線桿之時位關係

當針尖下降至勾針間隙約 1mm，撥線桿 A 正好由右始點向左移。(圖 26)

### TIMING POSITION AMONG NEEDLE, LOOPER, AND THE THREAD WIPER

When the needle top moves down to be 1 mm lower than the looper hole, the thread wiper A will right move to the left from the right dead point. (Fig. 26)

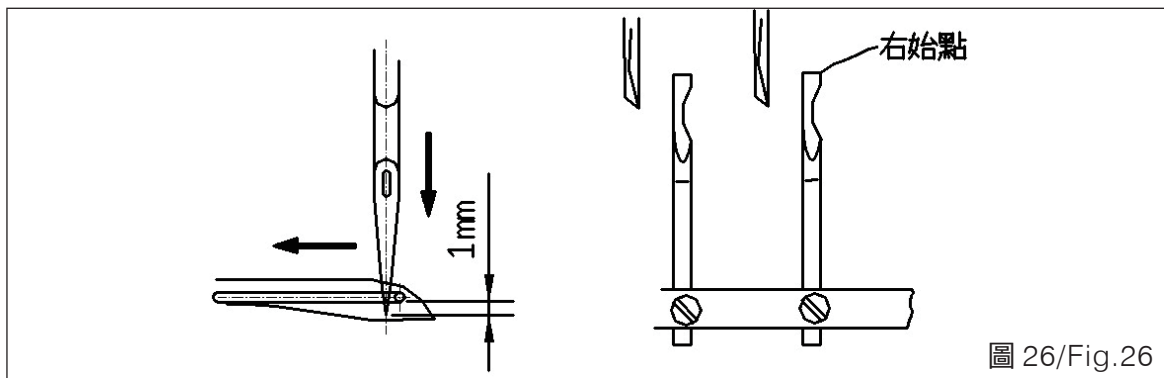

### 勾針線控線桿之調整

當針棒由上始點下降至車針位於勾針背面的中心位置時，勾針線控線 A 也正好由下始點往上抬起。(圖 27)

調整時：

1. 放鬆偏心凸輪 F 固定螺絲 C 前後調整至正確方位，再鎖緊螺絲 C，往前轉變快，往後轉變慢。

### ADJUST THE LOOPER THREAD CONTROL ROD

When the needle bar goes down from the upper dead point and the needle locates at the central of the looper rear side, the looper thread control rod A just happens to move upward from the lower dead point. (Fig.27)

Adjusting:

1. Loosen the fixed screw C of the eccentric F, and adjust it back and forth to the right position. Then, retighten the screw C. Turn the screw forward, the eccentric will be faster, where as turn it backward, the eccentric will be slower.

2. 微調整時，放鬆螺絲 E，將線導片 B 上下移動調整再鎖緊螺絲 E。

線の出線量因所使用的線而異，其出線量為：

棉線，S P 線 :7~10mm (D) (圖 28)

伸縮尼龍線 :10~15mm (D) (圖 28)

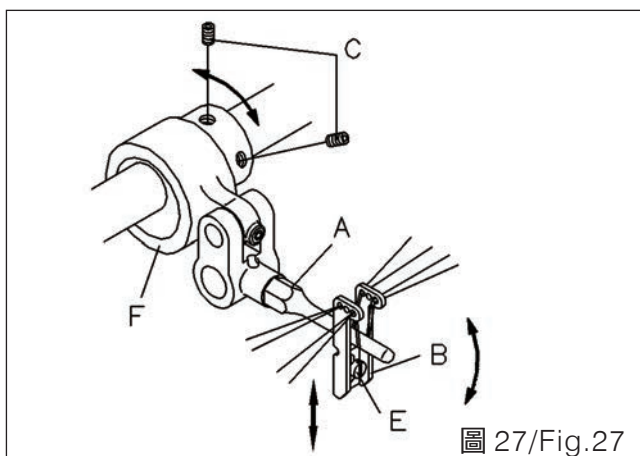

2. For doing micro-adjustment, loosen screw E, and move the thread guide B up and down to adjust. Then retighten the screw E.

The threading amount will be different because of the thread used.

The amount is:

Cotton, SP thread: 7~10mm (D) (Fig. 28)

Elastic Nylon thread: 10~15mm (D) (Fig. 28)

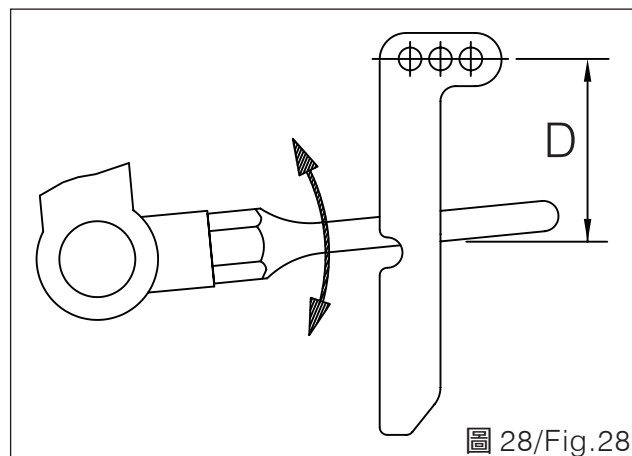

## 送具調整

## ADJUST THE FEED DOG

高度調整 (圖 29)

送具升至最高點時，送具齒尖面與針板面 A 之距離為 0.8~1.5mm，出廠值為 1.2mm。

Adjust the height (Fig. 29)

As the feed dog rise to the upmost, the distances from the gear top of feed dog to the face of needle plate A are 0.8-1.5mm. The Default is 1.2mm.

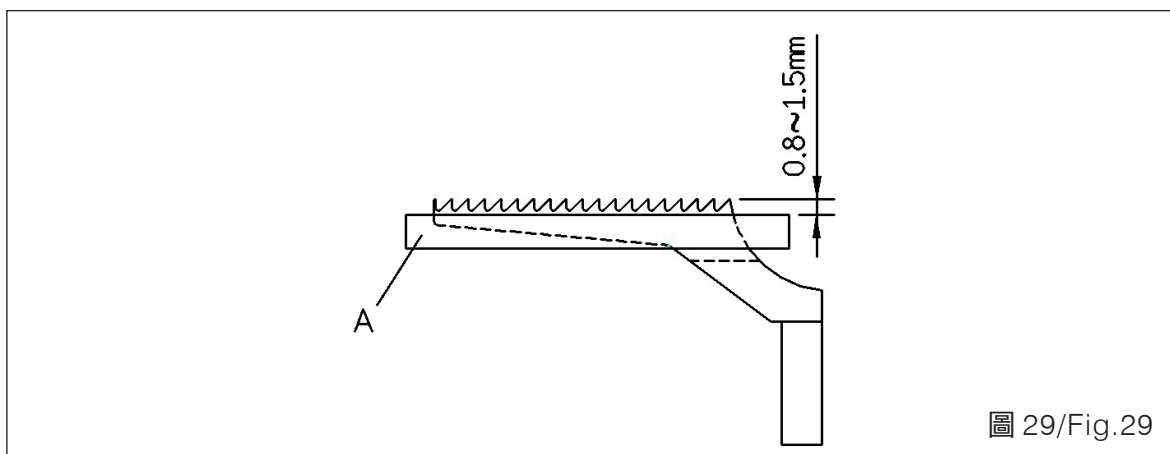

調整時參照 (圖 30)

1. 放鬆送具 C 固定螺絲 A。
2. 上下移動送具 C 使符合上述條件時，再鎖緊螺絲 A。
3. 將高度固定銷 D 之固定螺絲 B 放鬆，調整固定銷至頂，直至送具 C 底部再鎖緊螺絲 B。
4. 此時亦應確認送具 C 左右方向的平行。

When doing adjustment, please refer to (Fig.30).

1. Loosen the fixed screw A of the feed dog C.
2. Move the feed dog C up and down to match the condition mentioned above, and then tighten the screw A.
3. Loosen the fixed screw B of the height fixed pin D, and move the fixed pin to top. Lock the screw B after the pin D reach the bottom of the feed dog C.
4. At this moment, please confirm the parallel between the left and the right side of the feed dog C.



圖 30/ Fig.30

## 送具平行調整

## ADJUST THE FEED DOG'S PARALLEL

送具上升至上始點時應與針板平行。(圖 29)

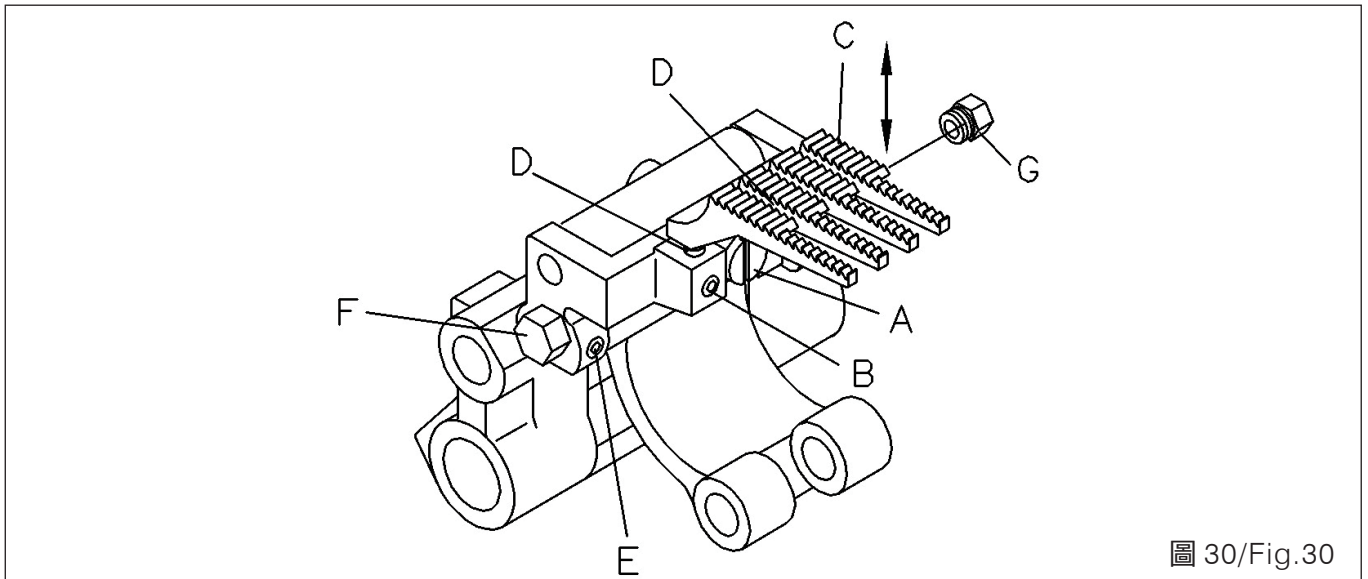
When the feed dog moves to the upper dead point, it should parallel the needle plate. (Fig. 29)

調整時：  
固定螺栓F，將螺帽G放鬆，調整送料具螺絲E，使送料具C與針板面平行，再鎖緊螺帽G。(圖 30)

For adjustments: (Fig. 30)  
Fasten the bolt F, and loosen the screw nut G. Then, adjust the screw E of the feed dog, so that the feed dog C can parallel the needle plate. Tighten screw nut G after that.

## 縫目之調整

## ADJUST THE STITCH

壓下按鈕A，並轉動皮帶輪，使按鈕卡住針具距調整組，再轉動皮帶輪至所需之縫目後，放開此按鈕。(圖 31)

Press the button A, and roll the belt wheel to make the button lock the needle distance adjustment set. After rotate the belt wheel to the desired stitch, release the button A. (Fig. 31)

調長縫目時，將皮帶輪往順時針方向旋轉，反之則小。

For longer stitch, rotate the belt wheel clockwise. Turn the wheel counter clockwise to have shorter stitch thereagainst.

調整縫目時，馬達需在停止狀態。

The motor must stay at dormant status while adjusting the stitch.



圖 31/Fig.31

## 後拉滾輪供給量之調整

供給量之調整 (一)：

1. 適用微量調整之情況。
2. 放鬆連桿螺帽後，參考 (圖 32) 往 A 移動供給量變大，往 B 移動則供給量變小。
3. 依縫紉情形適當調整。

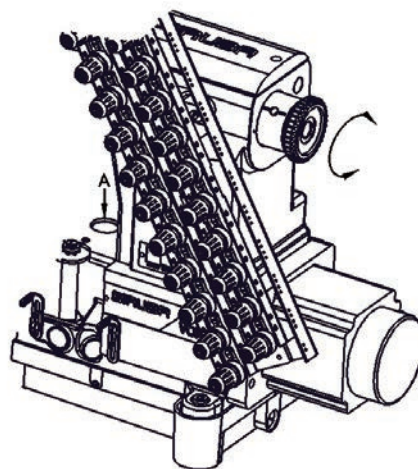
供給量之調整 (二)：

1. 取下橡膠塞蓋。
2. 放鬆連桿螺帽後，參考 (圖 33) 往 A 移動供給量變大，往 B 移動則供給量變小。
3. 依縫紉情形適當調整。

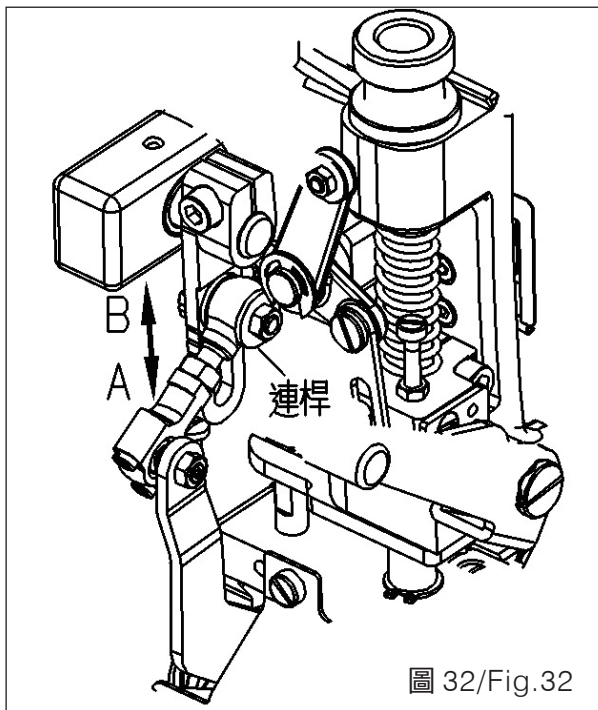

## ADJUST THE SUPPLEMENT OF THE REAR PULL WHEEL

FEEDING LENGTH ADJUSTMENT (一)

1. Applicable for slight adjustment condition.
2. Loose the nut of shaft. The movement to A becomes large. The movement to B becomes small (Fig.32).
3. The adjustment depends on actual sewing condition.

FEEDING LENGTH ADJUSTMENT (二)

1. Take off the rubber cover.
2. Loose the nut of shaft. The movement to A becomes large. The movement to B becomes small (Fig.33).
3. The adjustment depends on actual sewing condition.

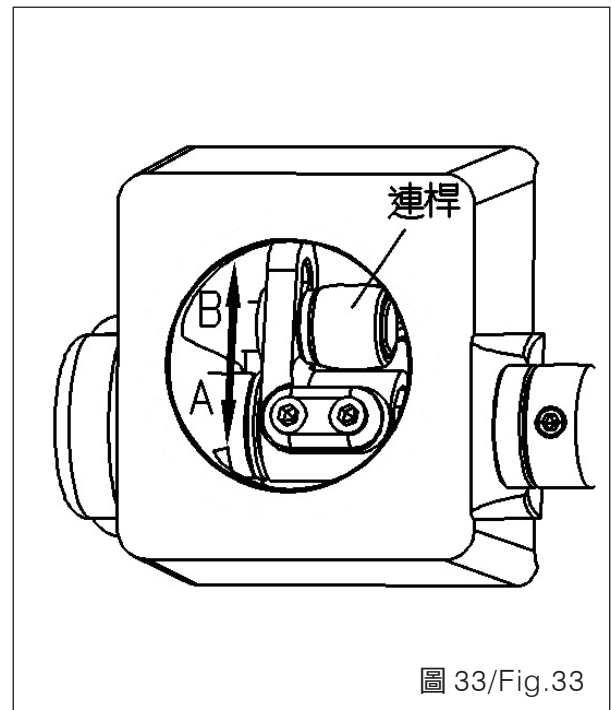

## 上下滾輪間隙調整

將上滾輪放至最低點，上滾輪與下滾輪之齒間隙為0.5 mm，且兩滾輪平行。(圖 34)

## ADJUST THE DISTANCE BETWEEN UPPER AND LOWER GEAR

Place the upper gear down to the lower dead point. The distance between the teeth of the upper and lower gear is 0.5mm, as well as they are parallel. (Fig. 34)

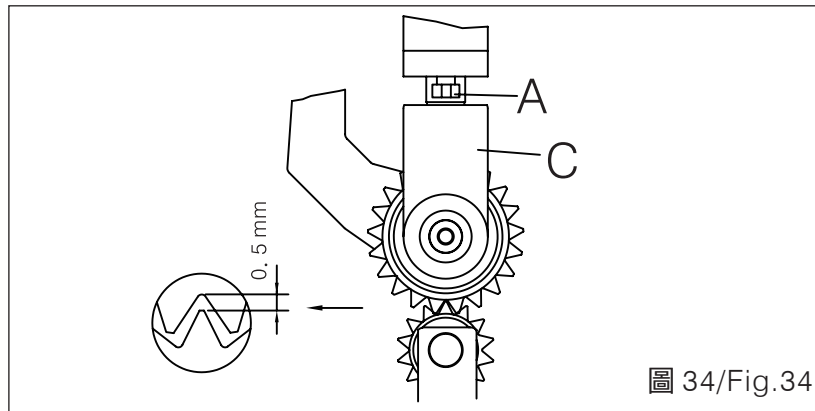

調整時：

1. 兩滾輪平行之調整(圖 34)  
將螺絲A放鬆，調整兩滾輪平行後，稍鎖緊螺絲A，上下移動固定座C，使上下滑動順暢，再鎖緊螺絲A。
2. 間隙0.5 mm之調整(圖 35)  
如圖35所示，將螺帽D及螺絲H放鬆，調整螺絲H，使上下滾輪之間隙為0.5 mm再鎖緊螺帽D，稍放鬆螺絲K並調整連桿J，使螺絲L與連桿J之長圓孔下方間隙為0.5 mm，再鎖緊螺絲K。

When adjusting:

1. Adjust the parallel condition of the two gears. (Fig. 34)  
Loosen screw A to parallel the 2 gears, and then tighten the screw A a little. Move the fixed seat C up and down to make sure the movement is smooth, and retighten the screw A tightly.
2. Adjust the distance of 0.5 mm. (Fig. 35)  
As shown in Fig. 35, loosen the screw nut D and screw nut H to adjust screw H to make the distance between upper and lower gear is 0.5 mm. Then, tighten the screw D. Loosen screw K a little, and adjust the connecting rod J to keep a distance of 0.5 mm from the screw L to the bottom of the long round hole of the connecting rod J. Then, retighten screw K.

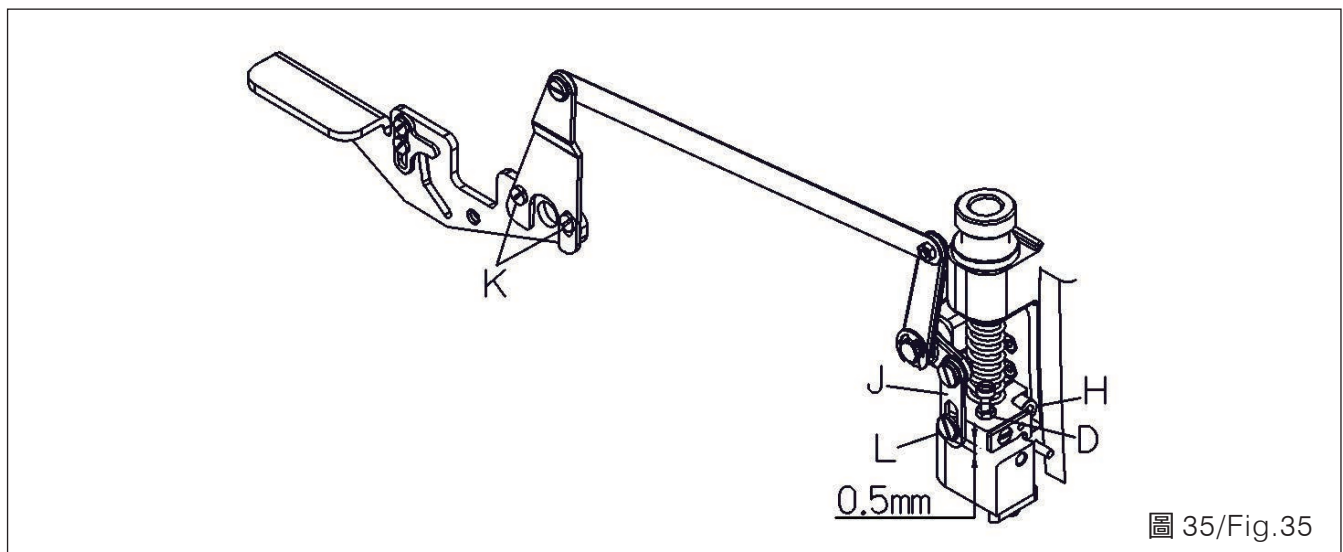

3. 上滾輪壓力之調整(圖 36)  
將壓力調整螺絲A往順時針方向轉動，則壓力加大，反之則減小。

3. Adjust the pressure of the upper gear.  
(Fig. 36)  
Rotate the pressure adjustment screw A clockwise, and the pressure will increase. Otherwise, the pressure will decrease.



圖 36/Fig.36

4. 上下滾輪之使用請參照表5

4. For the use of the upper and lower gear, please refer Table 5.

布料 Material	薄布料 (L)	中厚布料 (M)	厚布料 (H)
滾輪 Roller	平輪 (Flat Type) PU	齒輪 (Gear Type) POM(White)	齒輪 (Gear Type) POM(White)
上滾輪 Upper	● VCL16P	VCL37P(27T)	◎ VCL08P(22T)
下滾輪 Bottom	● VCL28	VCL33P(16T)	◎ VCL33(14T)

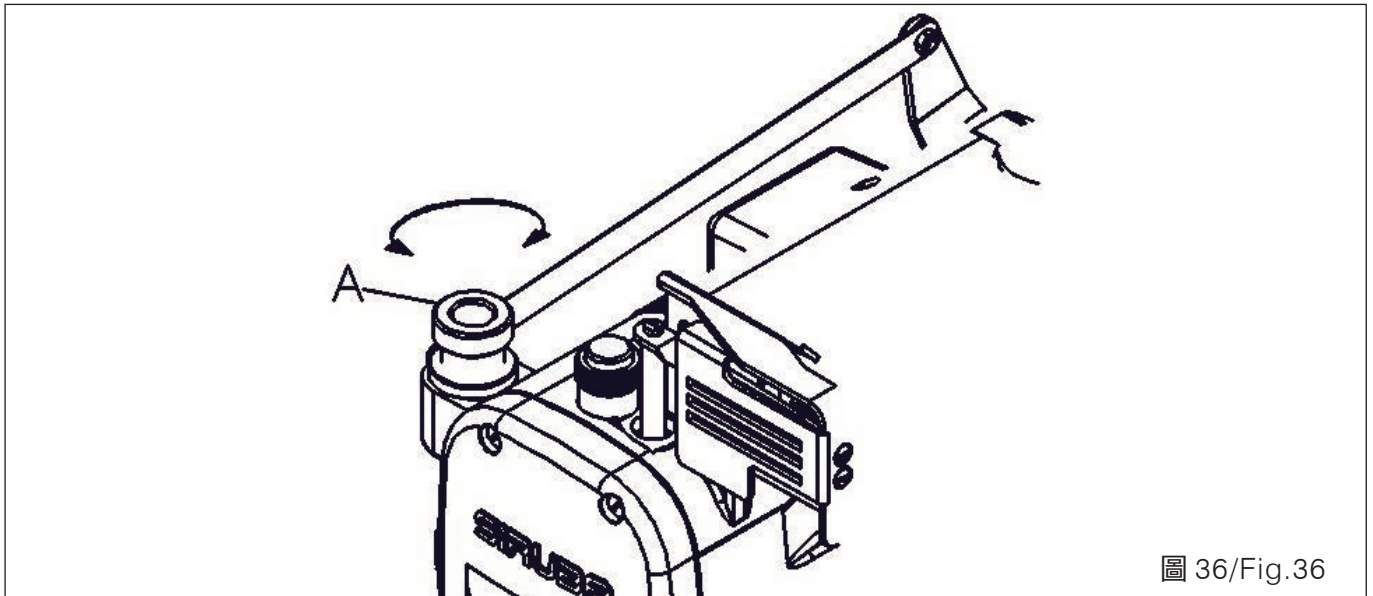
表 5/Table.5

<b>SIRUBA</b> <b>TABLE</b> <b>CUT - OUT</b>	<b>Series</b>	<b>Item Code</b>	<b>Subclass Remark</b>	<b>Mounting</b>
	<b>VC008</b> <b>VC008A</b> <b>VC008B</b>	<b>VC008-T1</b>	For VC008(A, B)-04 VC008(A, B)-04P/VCE VC008(A, B)-04P/VUT VC008(A, B)-04P/VSF	<b>Semi-submerged</b>
				<b>Date</b>
				<b>2019/11/06</b>

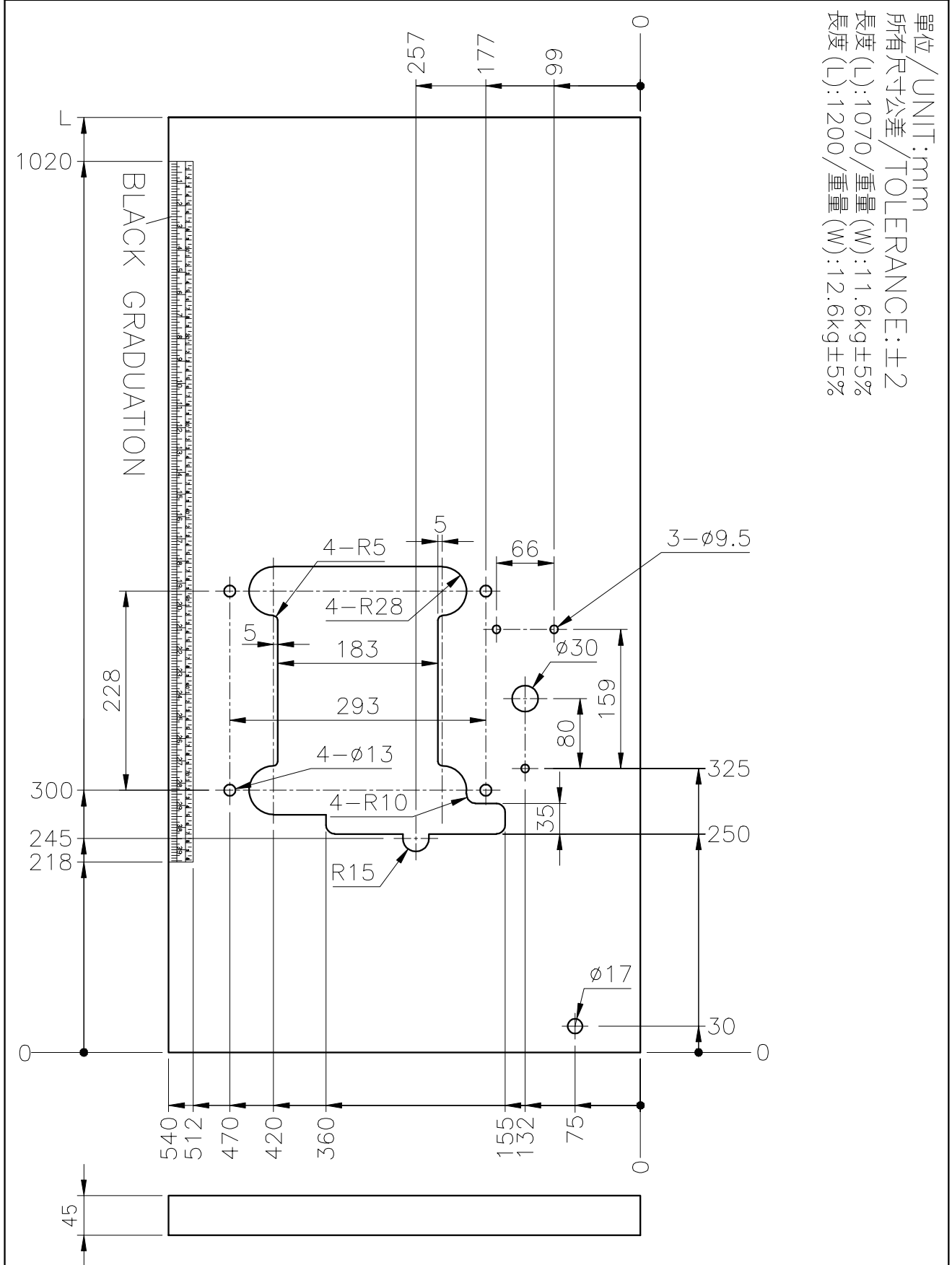



SIRUBA TABLE CUT - OUT	Series	Item Code	Subclass Remark	Mounting
	VC008 VC008A VC008B	VC008-T2	For VC008(A, B)-04 VC008(A, B)-04P/VCE VC008(A, B)-04P/VJT VC008(A, B)-04P/VSF	Non-submerged
				Date

2019/11/06

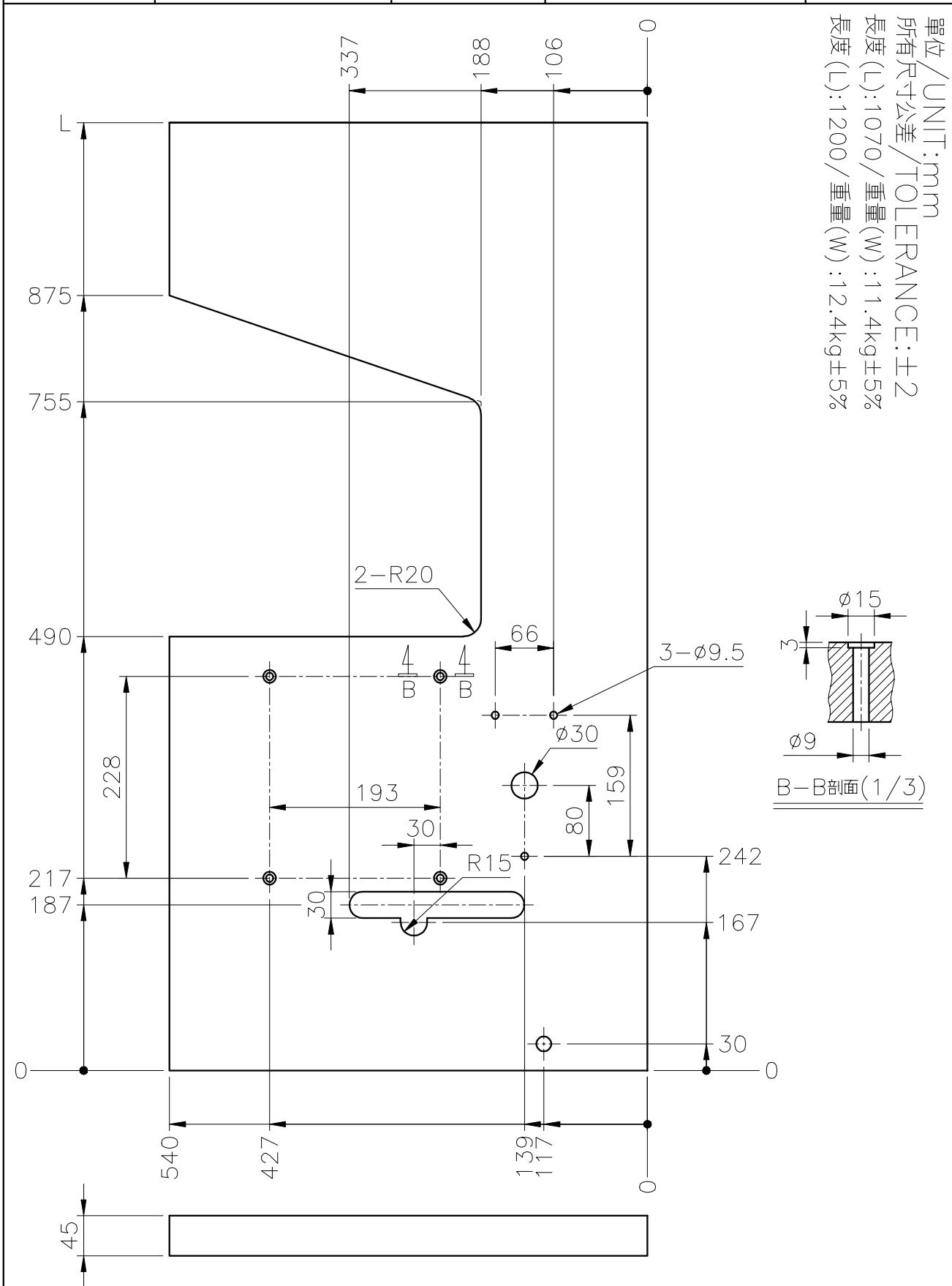

<b>SIRUBA</b> <b>TABLE</b> <b>CUT - OUT</b>	<b>Series</b>	<b>Item Code</b>	<b>Subclass Remark</b>	<b>Mounting</b>
	VC008 VC008A VC008B	VC008-T3	For VC008(A, B)-12, VC008(A)-13 VC008(A, B)-06/VPL VC008(A)-12/VPQ VC008(A, B)-12/VPT VC008(A, B)-12/VUT	<b>Semi-submerged</b>
				<b>Date</b> 2019/11/06

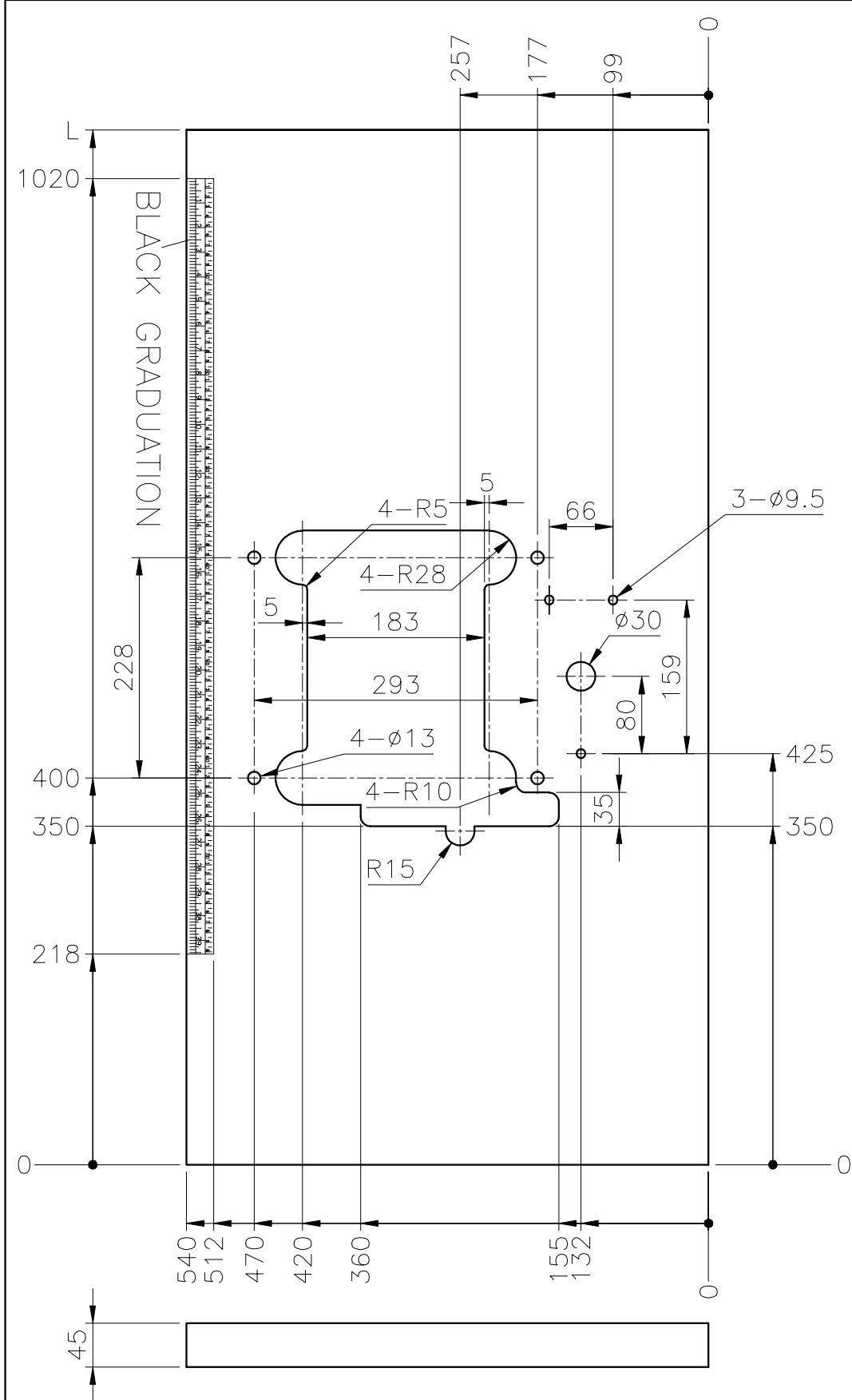

單位/UNIT:mm  
所有尺寸公差/TOLERANCE:±2  
長度(L):1070/重量(W):11.6kg±5%  
長度(L):1200/重量(W):12.6kg±5%



<b>SIRUBA</b>  <b>PARTS LIST</b>	Series	Parts Group	Subclass / Remark	Page
	<b>VC008B</b>	<b>VA</b>	● FOR 12 NEEDLE	1/1
				Date
				2020/05/18

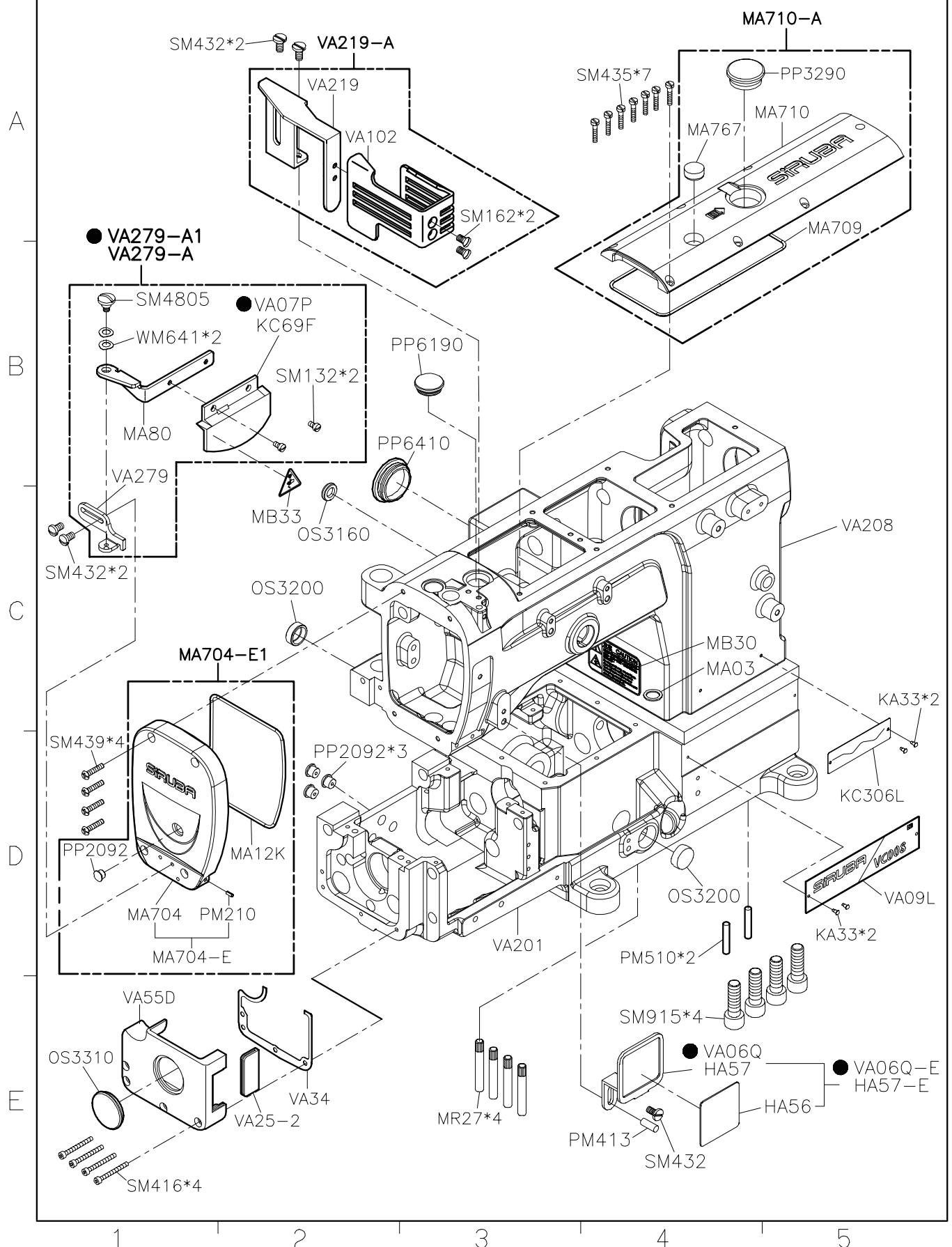



SIRUBA PARTS LIST	Series	Parts Group	Subclass / Remark	Page
	VC008B	VC		1/1
				Date
				2020/05/18

L + M = VD43-A  
 VD VC

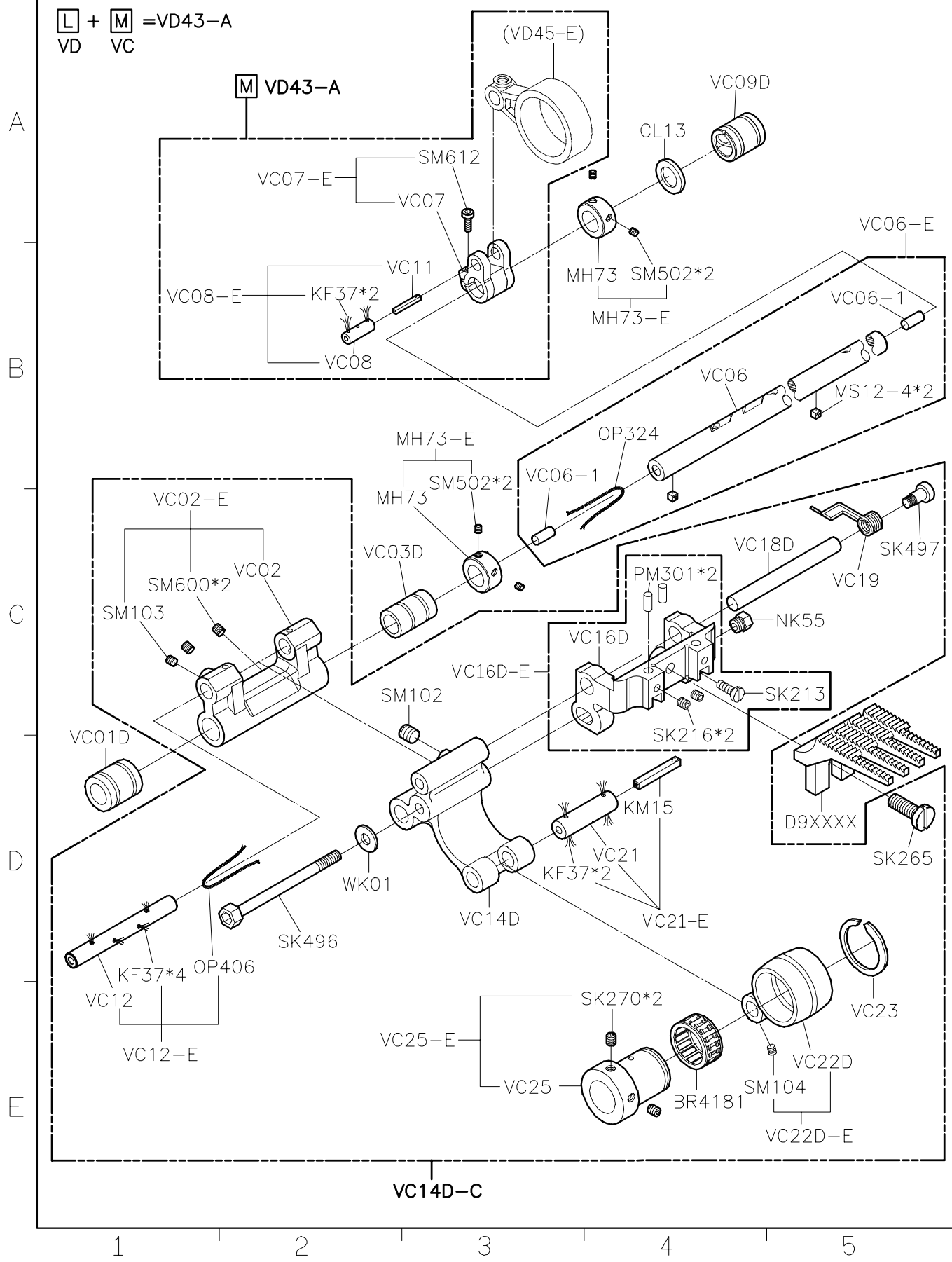

SIRUBA PARTS LIST	Series	Parts Group	Subclass / Remark	Page
	VC008B	VD		1/1
				Date
				2020/05/18

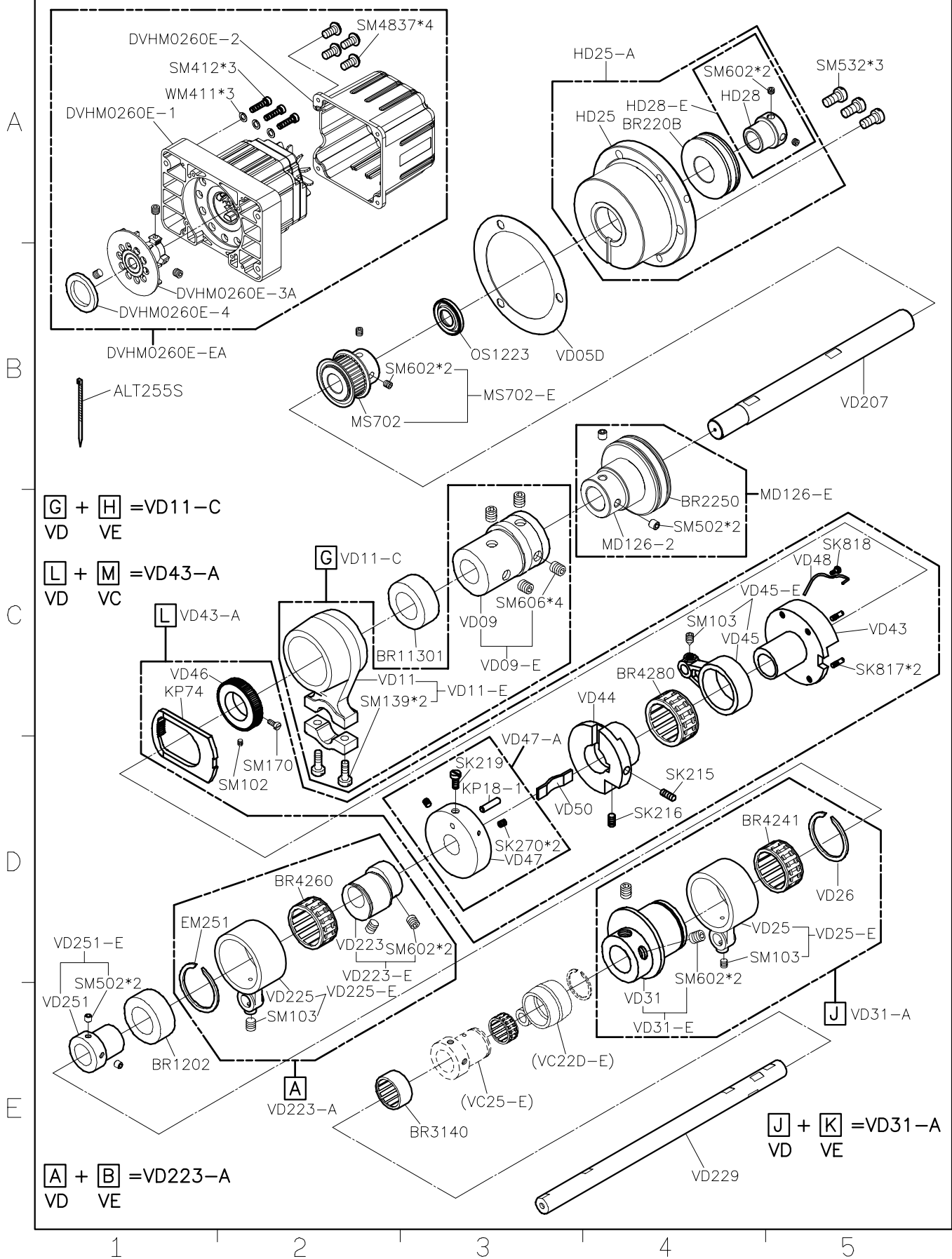

<b>SIRUBA</b> <b>PARTS LIST</b>	<b>Series</b>	<b>Parts Group</b>	<b>Subclass / Remark</b>	<b>Page</b>
	<b>VC008B</b>	<b>VE</b>	● FOR 12 NEEDLE	1/2
				<b>Date</b> 2020/05/18

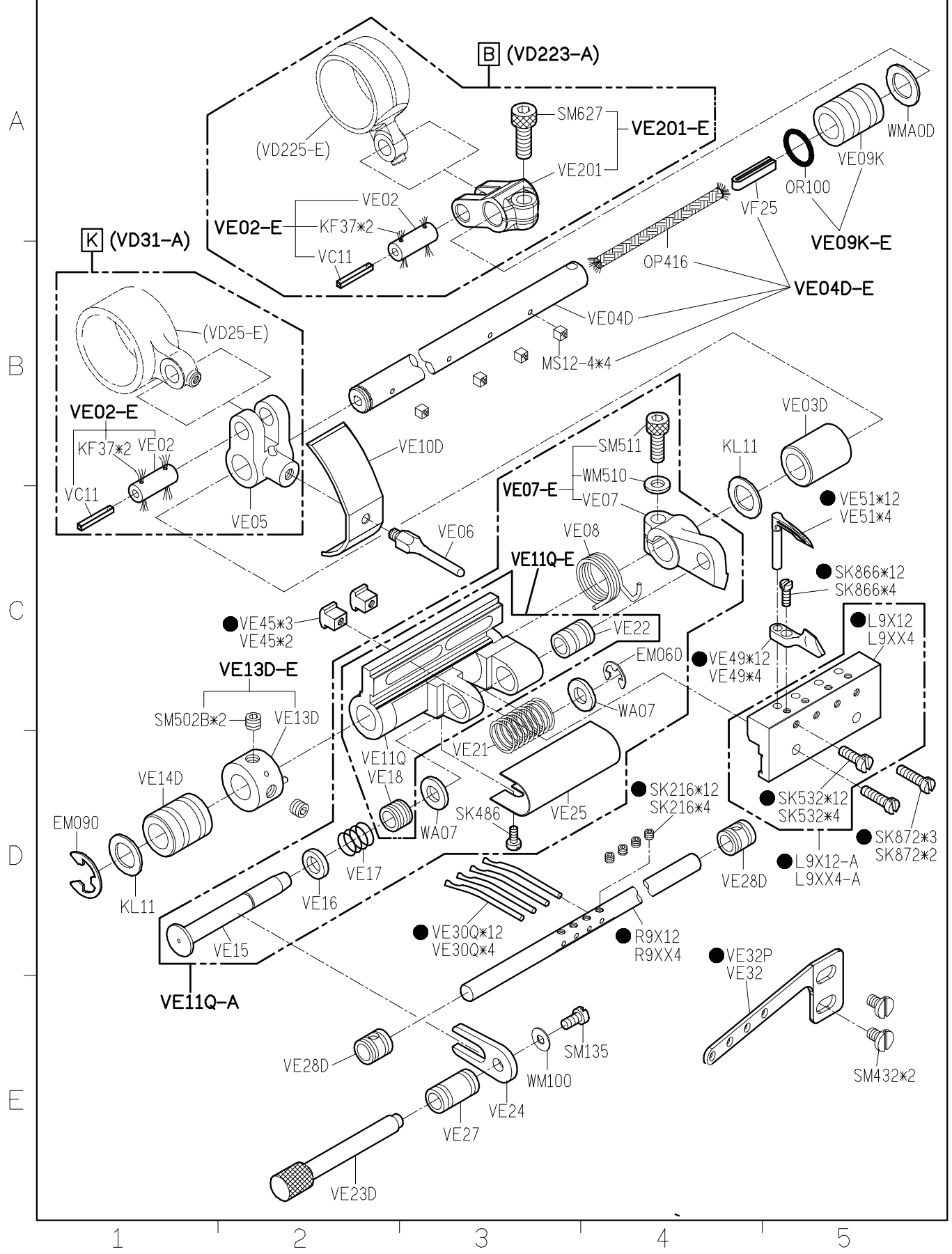



SIRUBA PARTS LIST	Series	Parts Group	Subclass / Remark	Page
	VC008B	VE		2/2
				Date
				2020/05/18

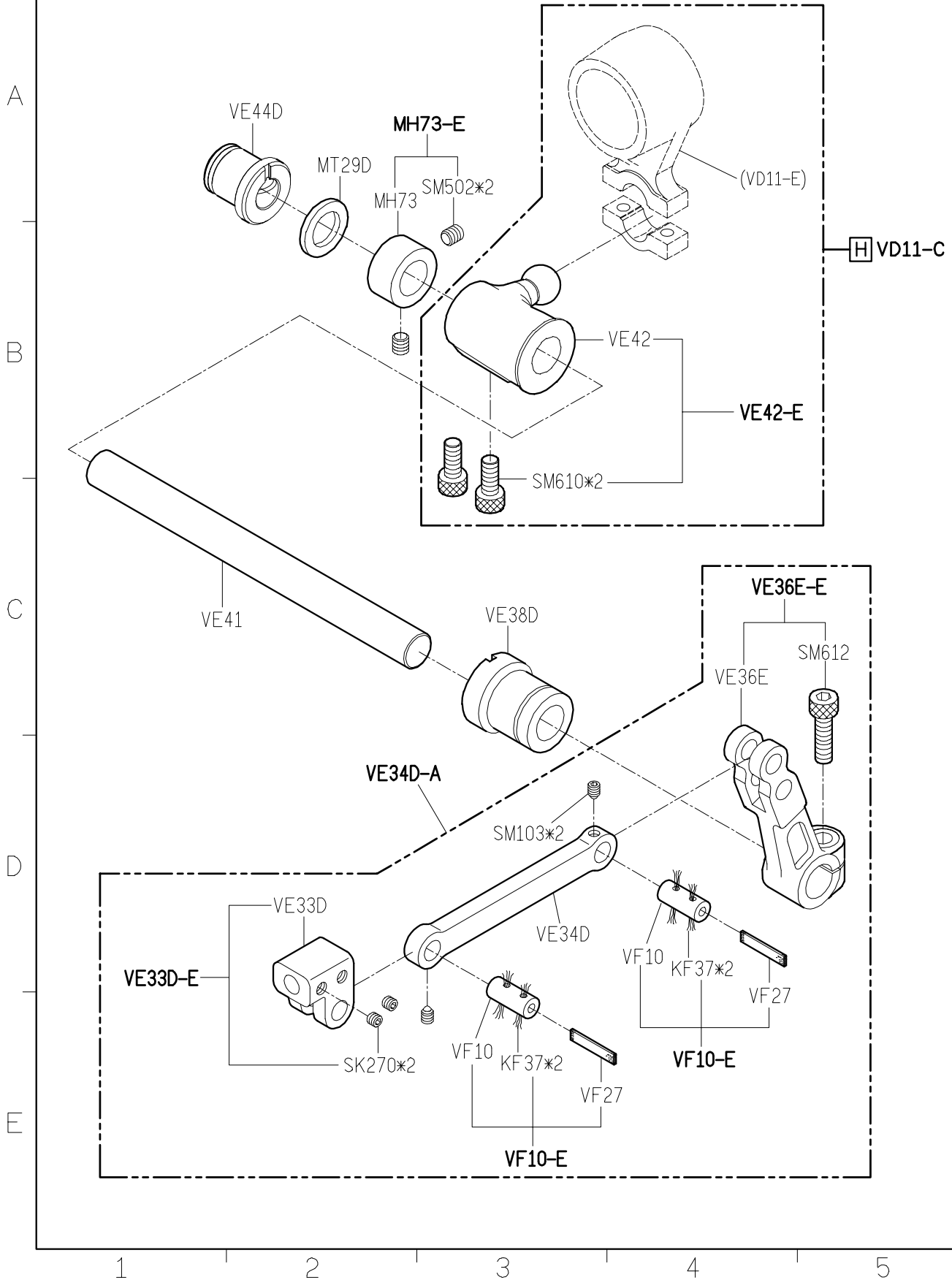



SIRUBA PARTS LIST	Series	Parts Group	Subclass / Remark	Page
	VC008B	VF	● FOR 12 NEEDLE	2/3
				Date
				2020/05/18

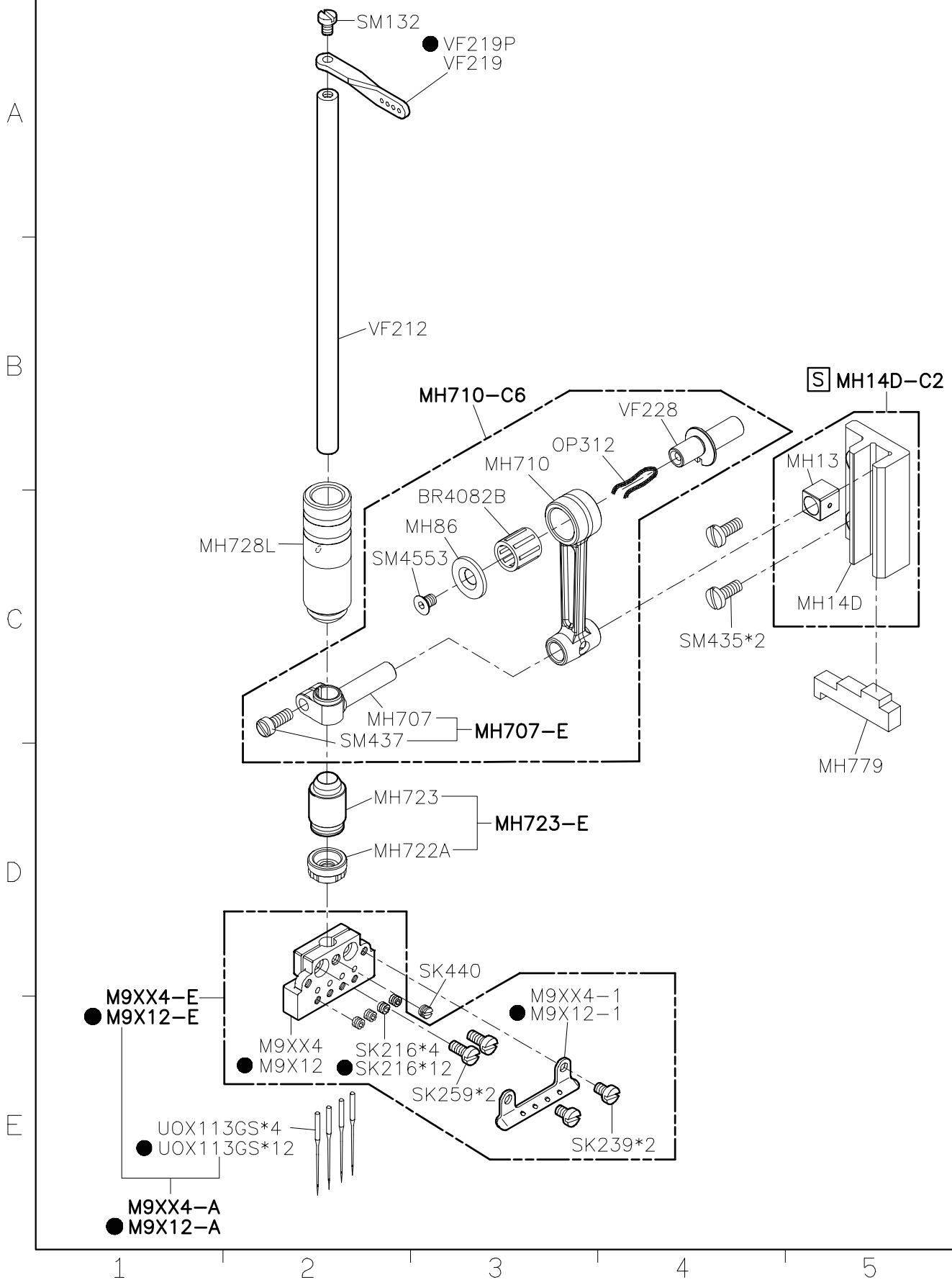

SIRUBA PARTS LIST	Series	Parts Group	Subclass / Remark	Page
	VC008B	VF	● FOR 12 NEEDLE	3/3
				Date
				2020/02/11

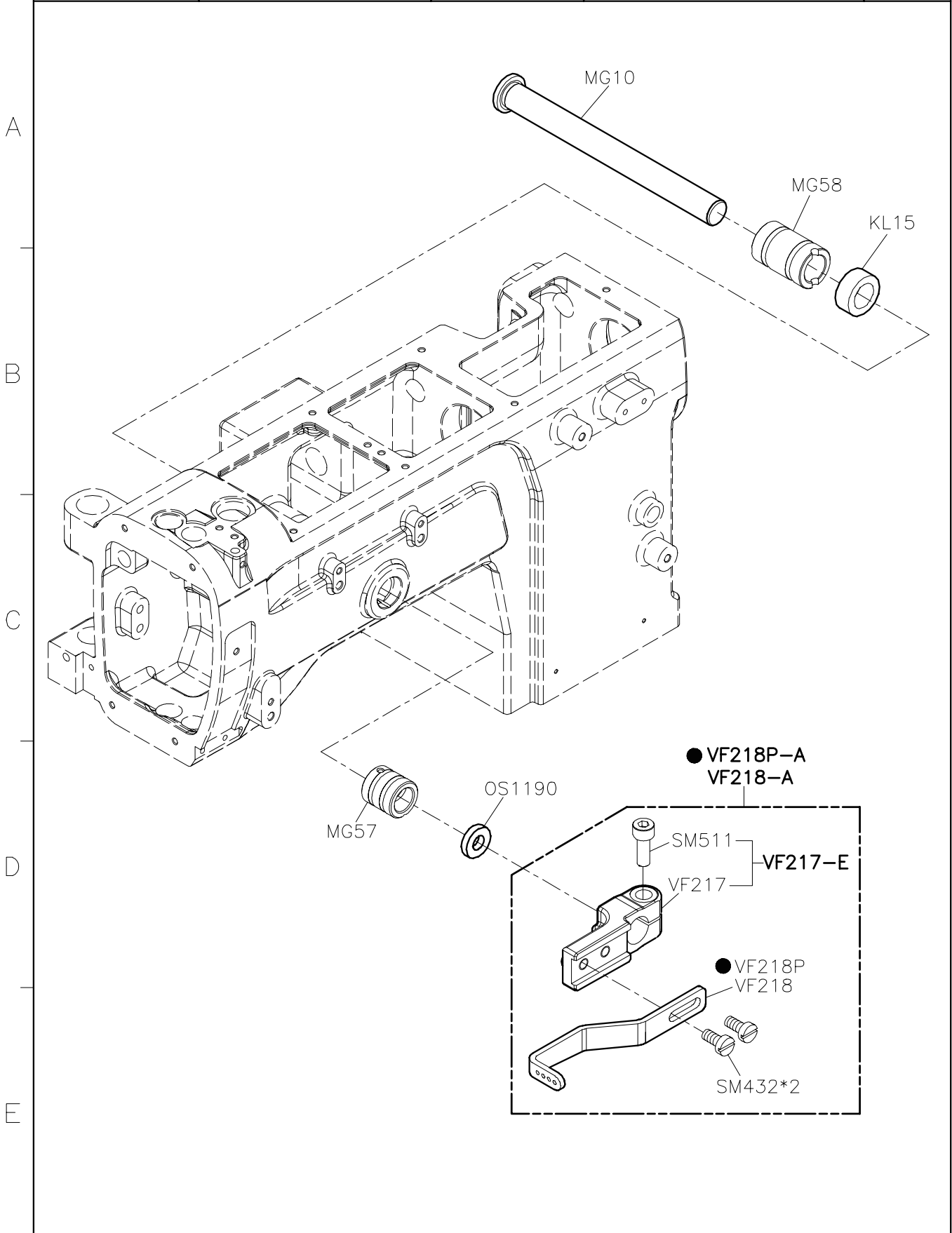

<b>SIRUBA</b> <b>PARTS LIST</b>	<b>Series</b>	<b>Parts Group</b>	<b>Subclass / Remark</b>	<b>Page</b>
	<b>VC008B</b>	<b>VJ</b>	● FOR 12 NEEDLE	1/1
				<b>Date</b>
				2020/05/18

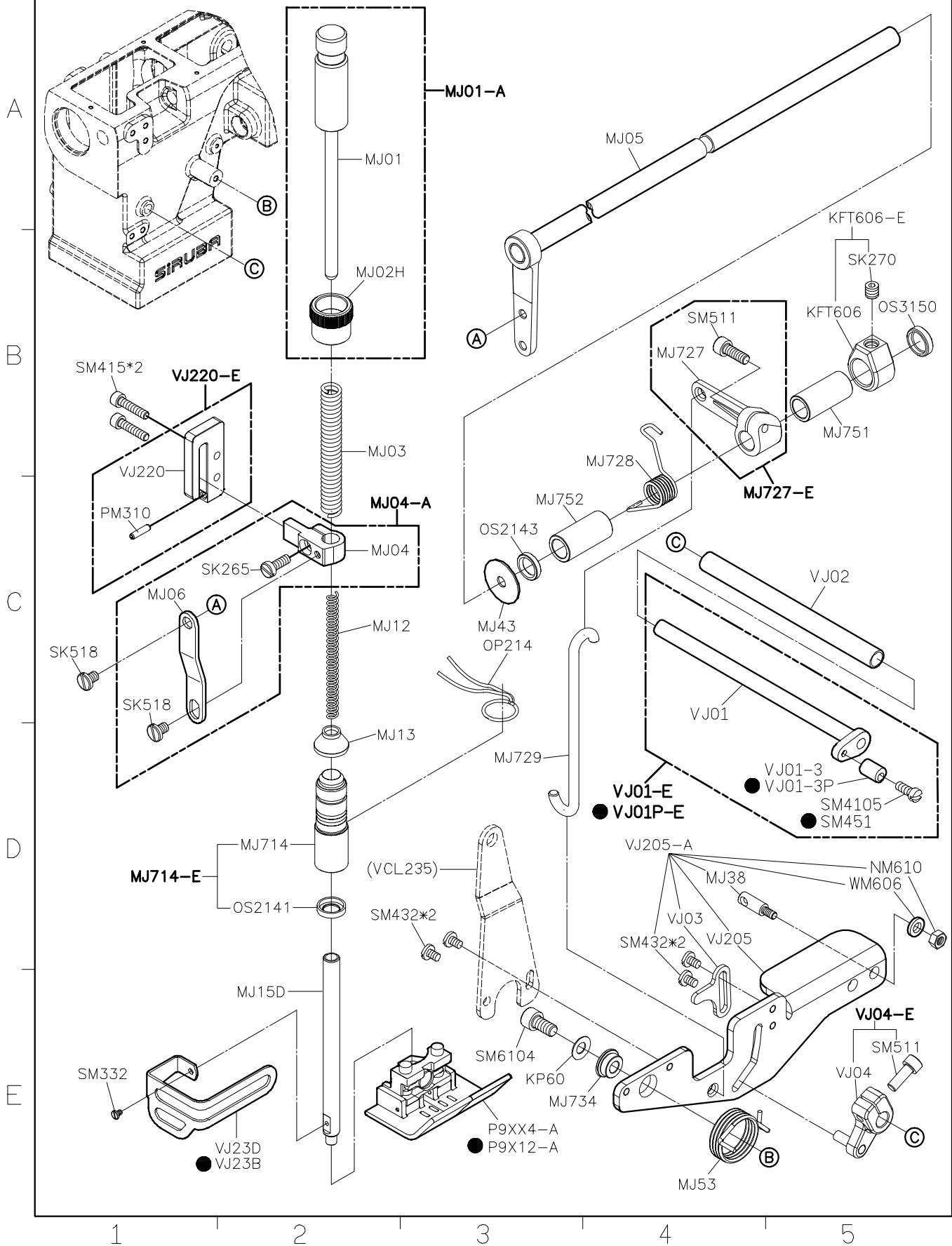

SIRUBA PARTS LIST	Series	Parts Group	Subclass / Remark	Page
	VC008B	VK	FOR 4 NEEDLE	1/2
				Date
				2020/05/18

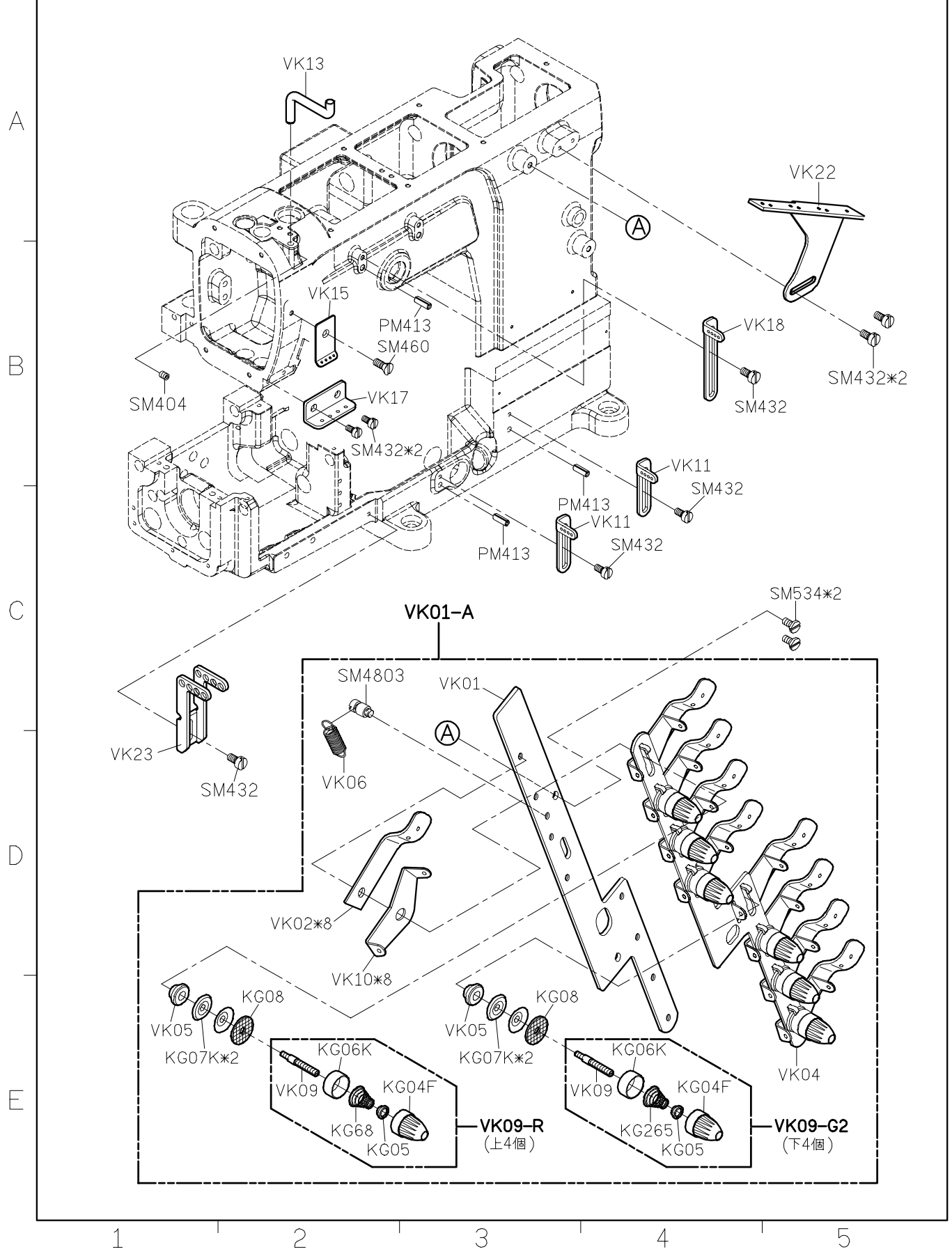

SIRUBA PARTS LIST	Series	Parts Group	Subclass / Remark	Page
	VC008B	VK	FOR 12 NEEDLE	2/2
				Date
				2020/05/18

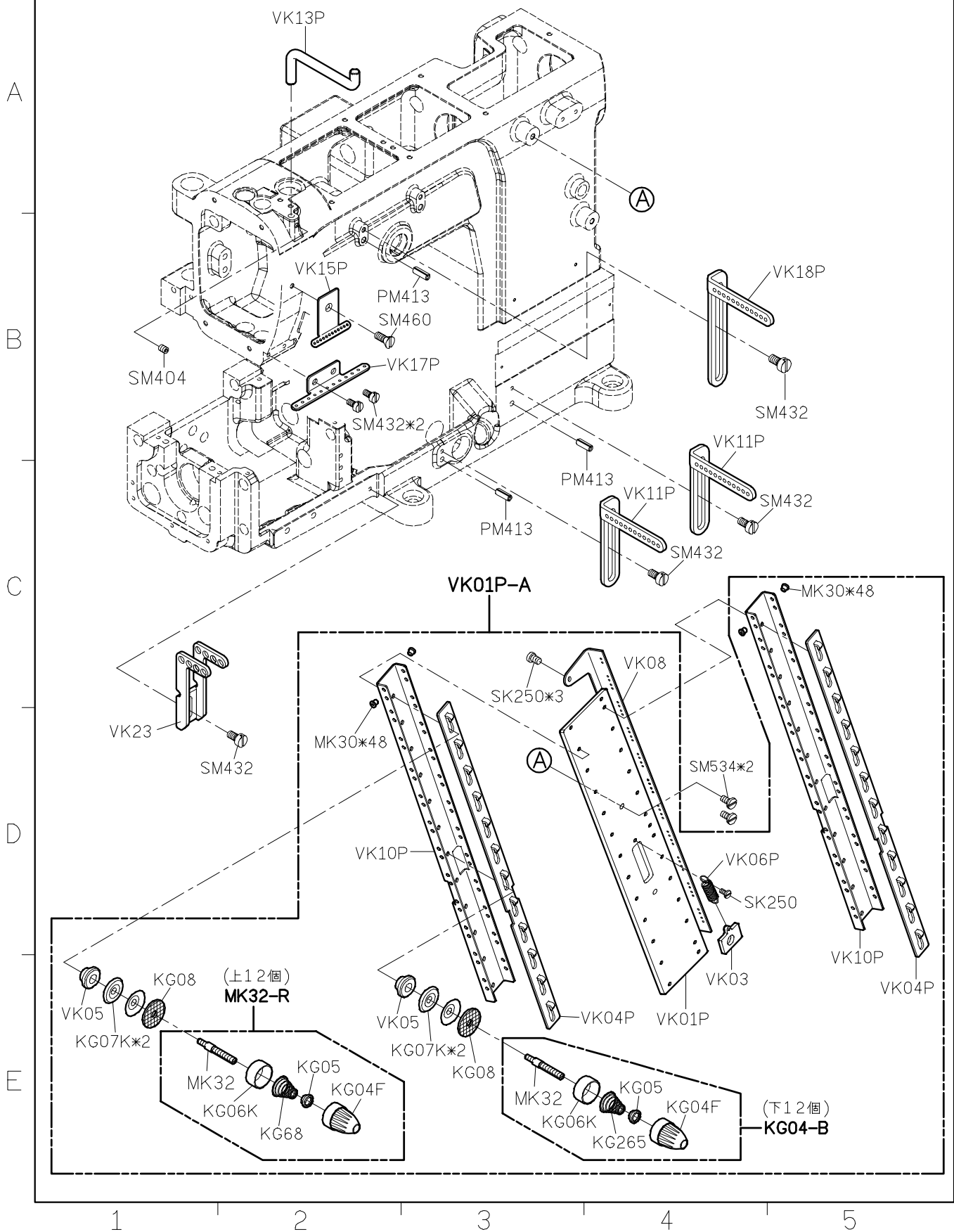

SIRUBA PARTS LIST	Series	Parts Group	Subclass Remark	Page
	VC008B	VL		1/1
				Date
				2020/05/18

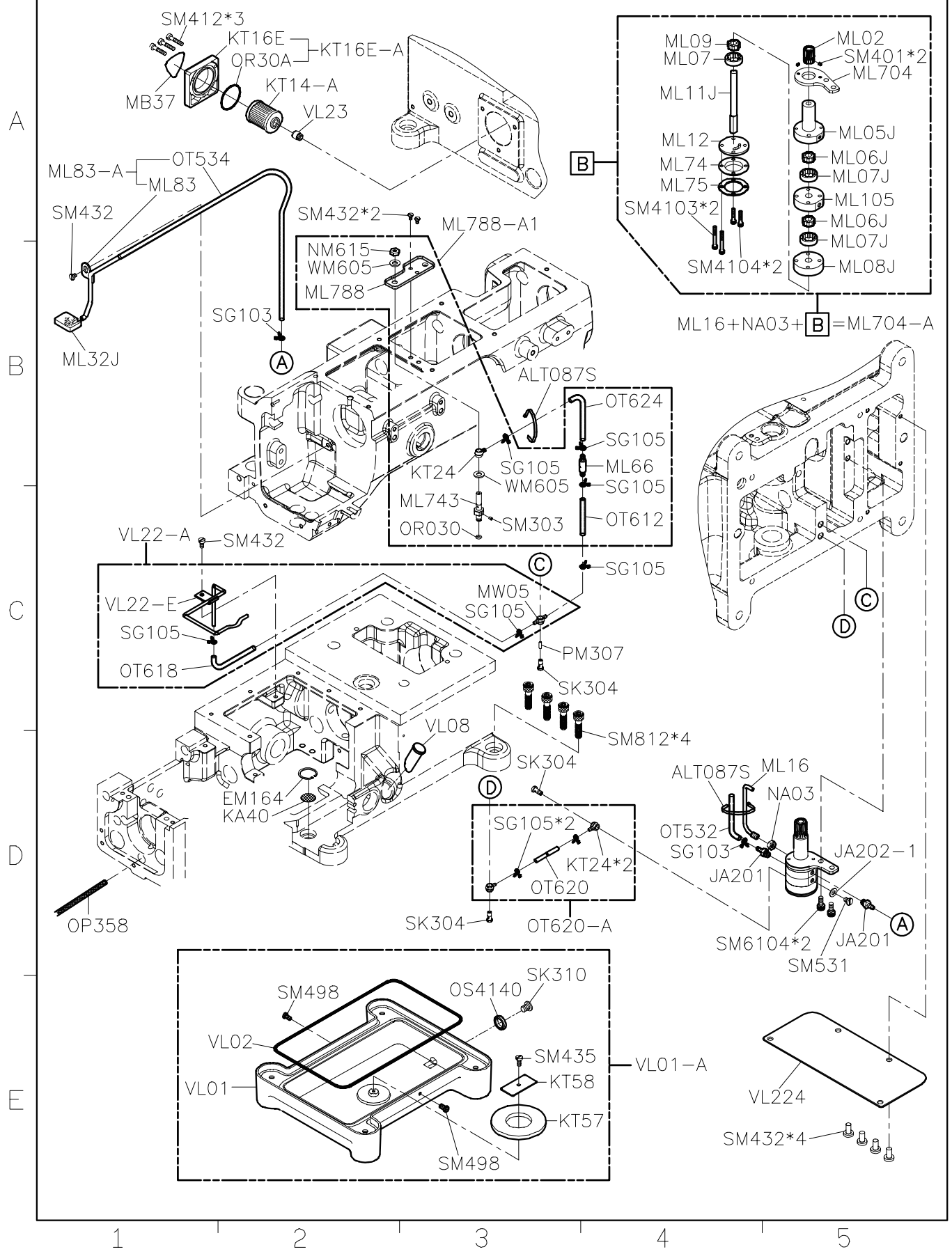



<b>SIRUBA</b> <b>PARTS LIST</b>	<b>Series</b>	<b>Parts Group</b>	<b>Subclass / Remark</b>	<b>Page</b>
	<b>VC008B</b>	<b>VCL</b>	△ CL02, BR4243需再和 CL701-E選配	1/3
				<b>Date</b> 2020/01/17

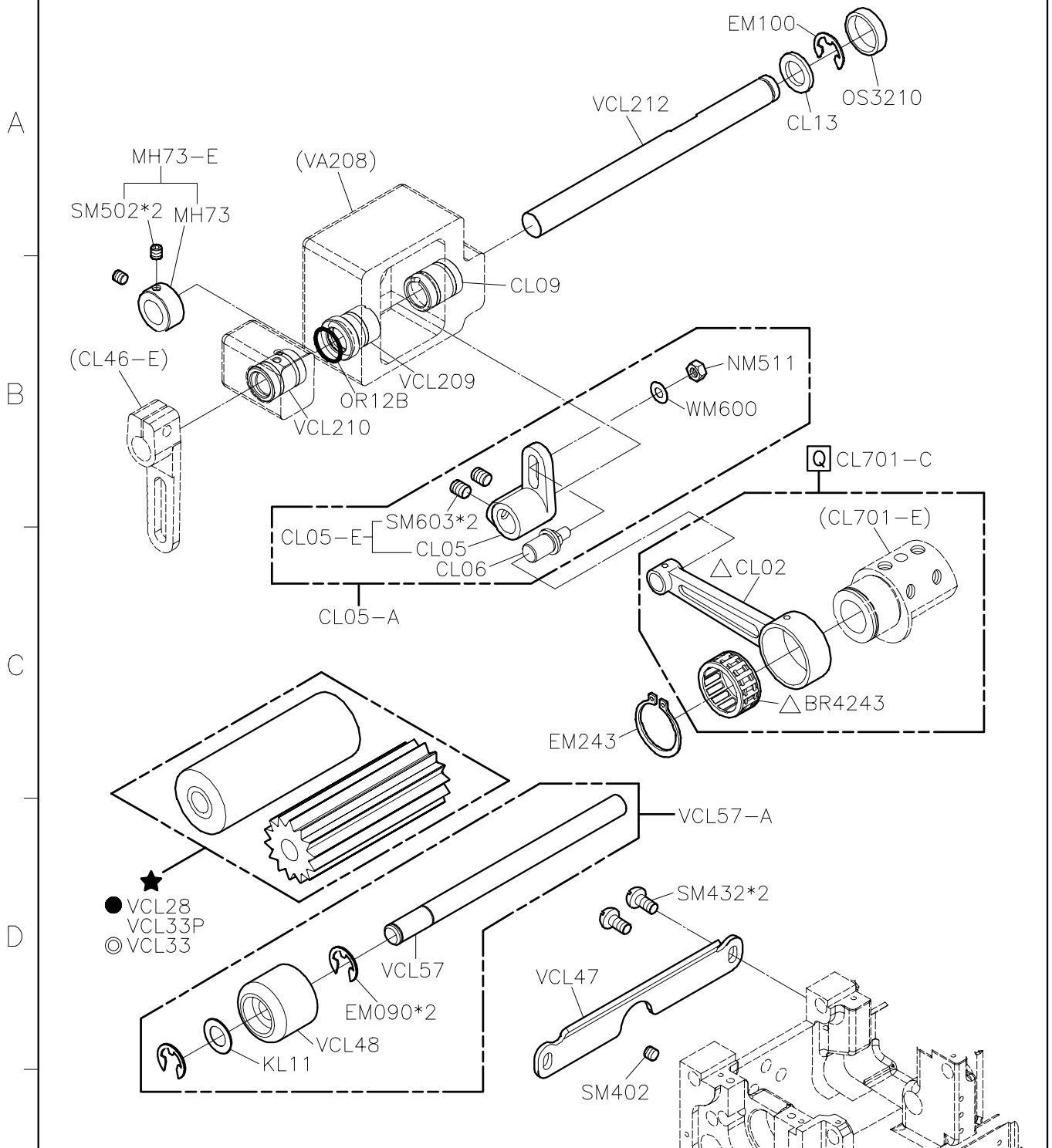

★ 滾輪使用方式

布料 Material	薄布料(L)	中厚布料(M)	厚布料(H)
滾輪 Roller	平輪(Flat Type) PU	齒輪(Gear Type) POM(White)	齒輪(Gear Type) POM(White)
上滾輪 Upper	● VCL16P	VCL37P(27T)	◎ VCL08P(22T)
下滾輪 Bottom	● VCL28	VCL33P(16T)	◎ VCL33(14T)

1 2 3 4 5

SIRUBA PARTS LIST	Series	Parts Group	Subclass / Remark	Page
	VC008B	VCL		2/3
				Date
				2020/05/18

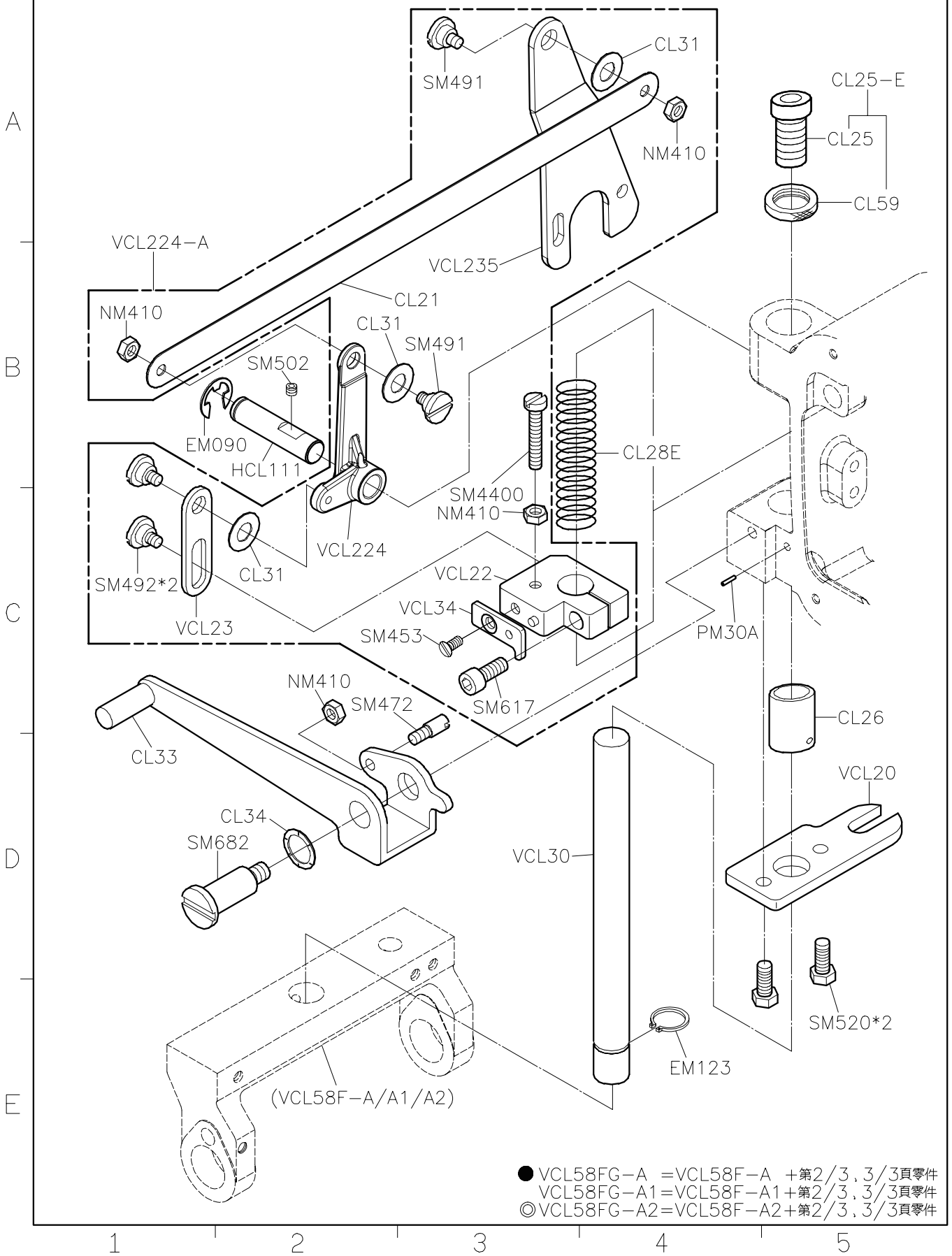



SIRUBA PARTS LIST	Series	Parts Group	Subclass / Remark	Page
	VC008B	VN	Use for 半沉式桌板	1/3
				Date
				2020/05/18

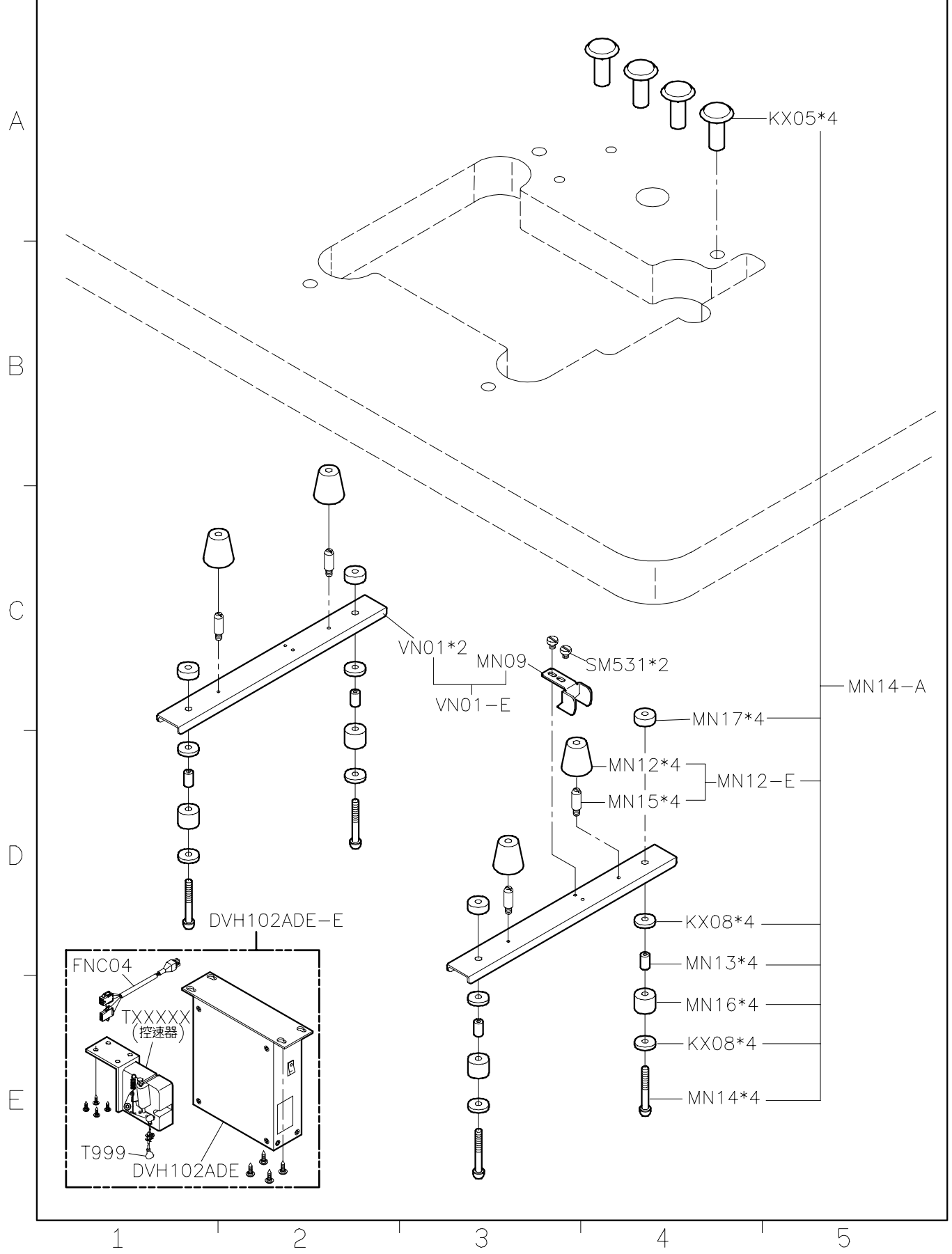

SIRUBA PARTS LIST	Series	Parts Group	Subclass / Remark	Page
	VC008B	VN	Use for 上乘式桌板	2/3
				Date
				2019/11/22

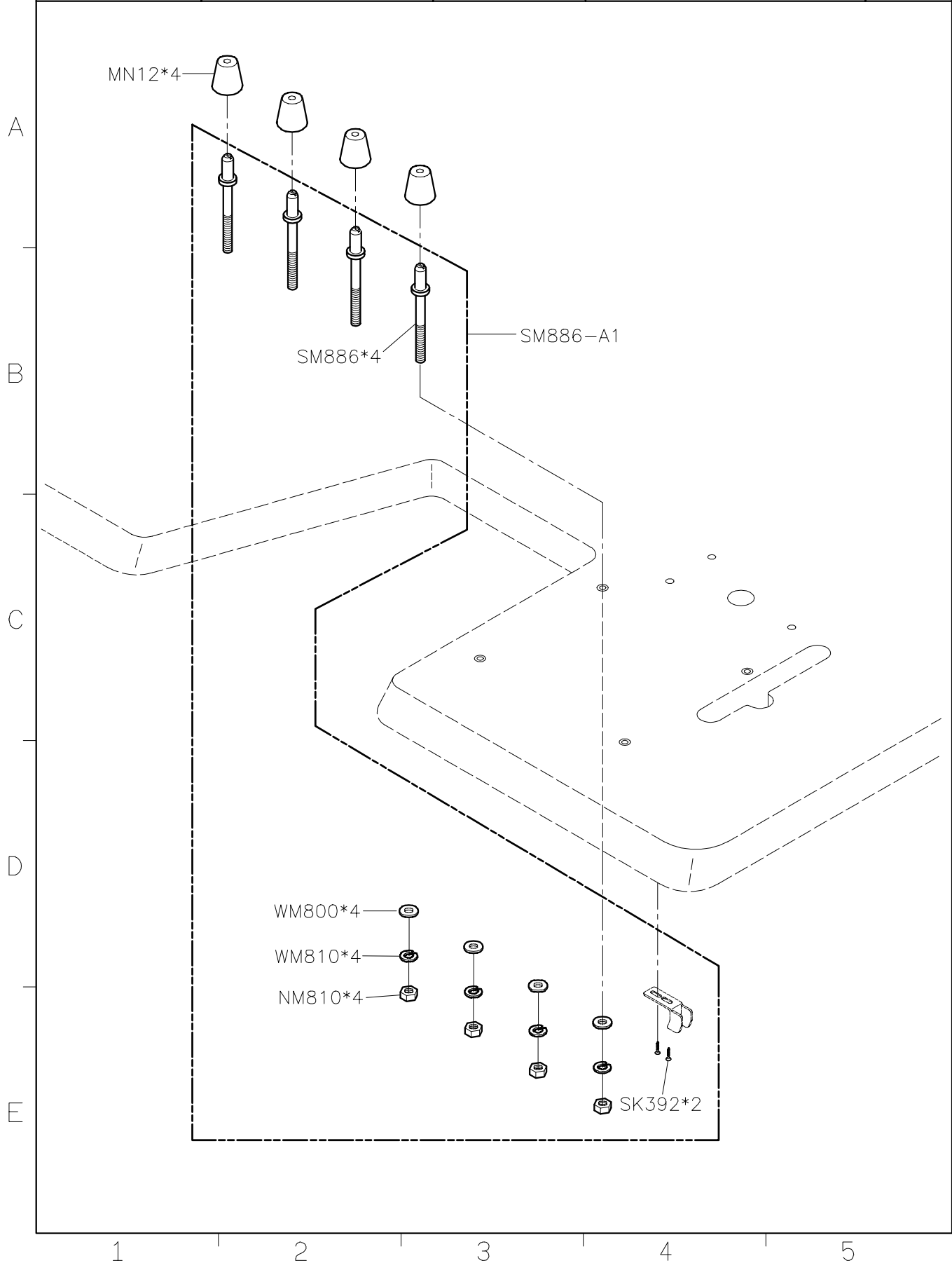

SIRUBA PARTS LIST	Series	Parts Group	Subclass / Remark	Page
	VC008B	VN	Use for 全沉式桌板	3/3
				Date
				2019/11/22

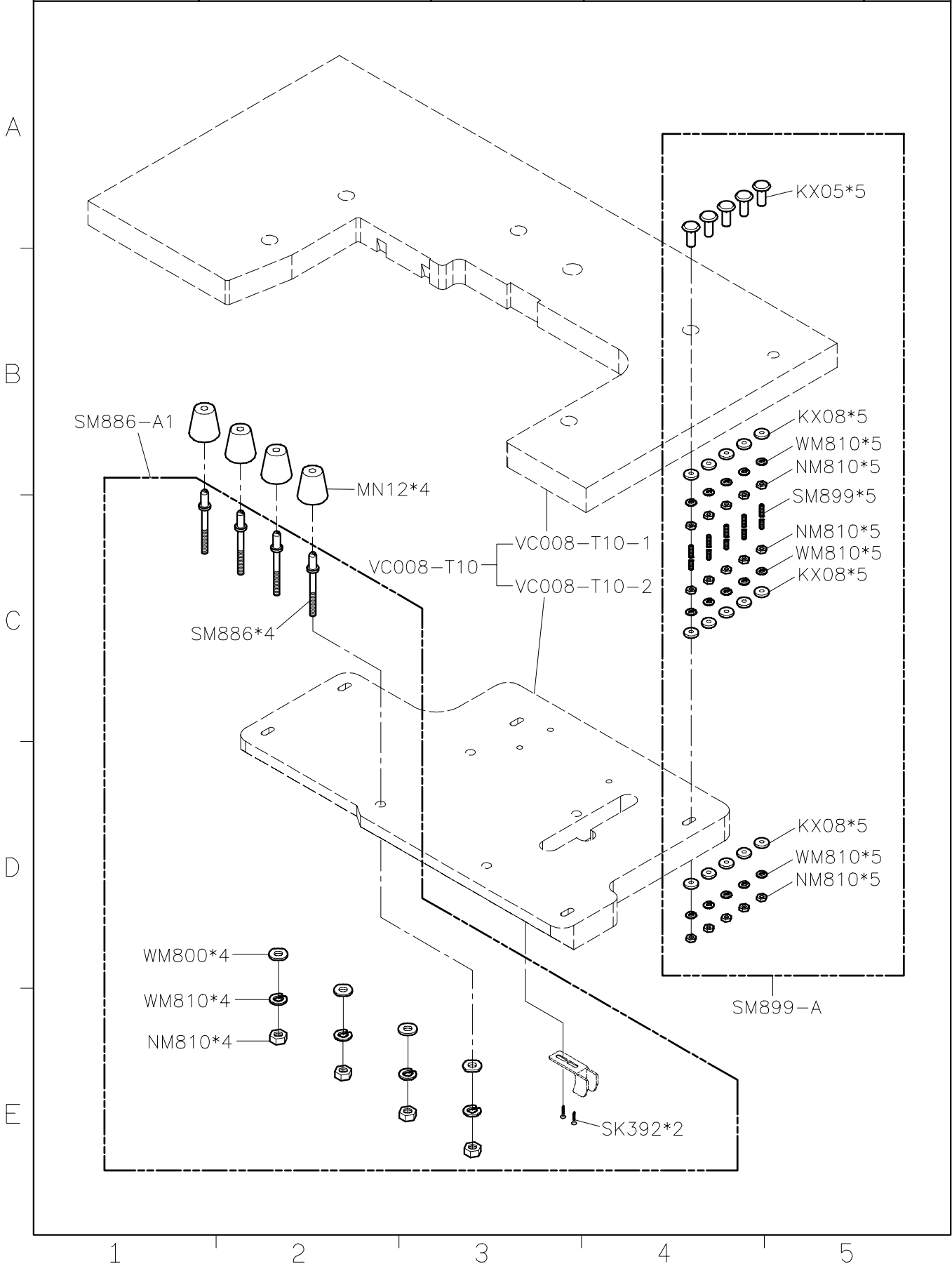



SIRUBA PARTS LIST	Series	Parts Group	Subclass / Remark	Page
	VC008B	VY	△ 大陸地區內銷用	2/2
				Date
				2020/05/18

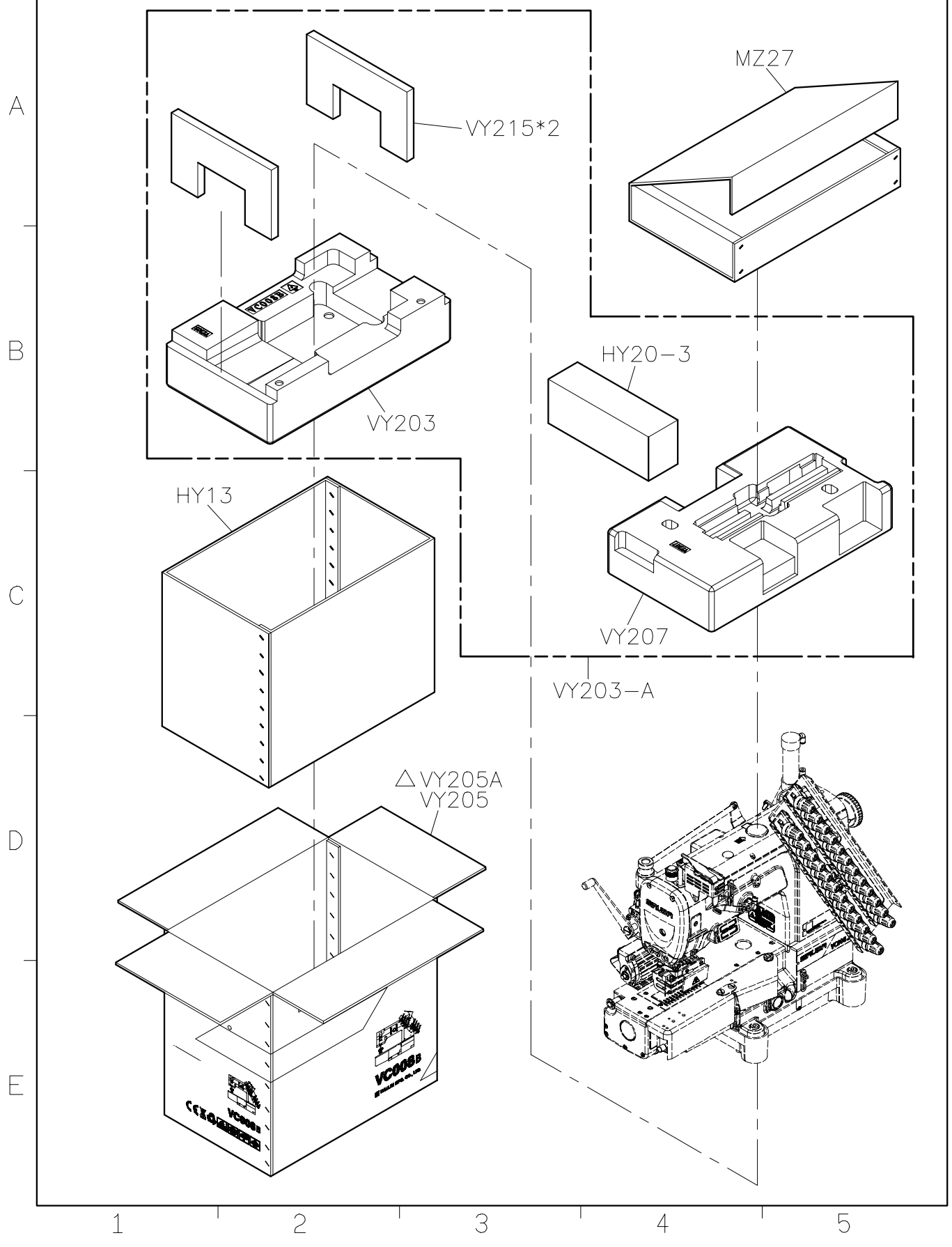



<b>SIRUBA</b> <b>PARTS LIST</b>	<b>Series</b>	<b>Parts Group</b>	<b>Subclass / Remark</b>	<b>Page</b>
	<b>VC008B</b>	<b>VZ</b>	OPTION:VZ02-A (4 NEEDLE USE)	1/2
				<b>Date</b>
				2019/11/18

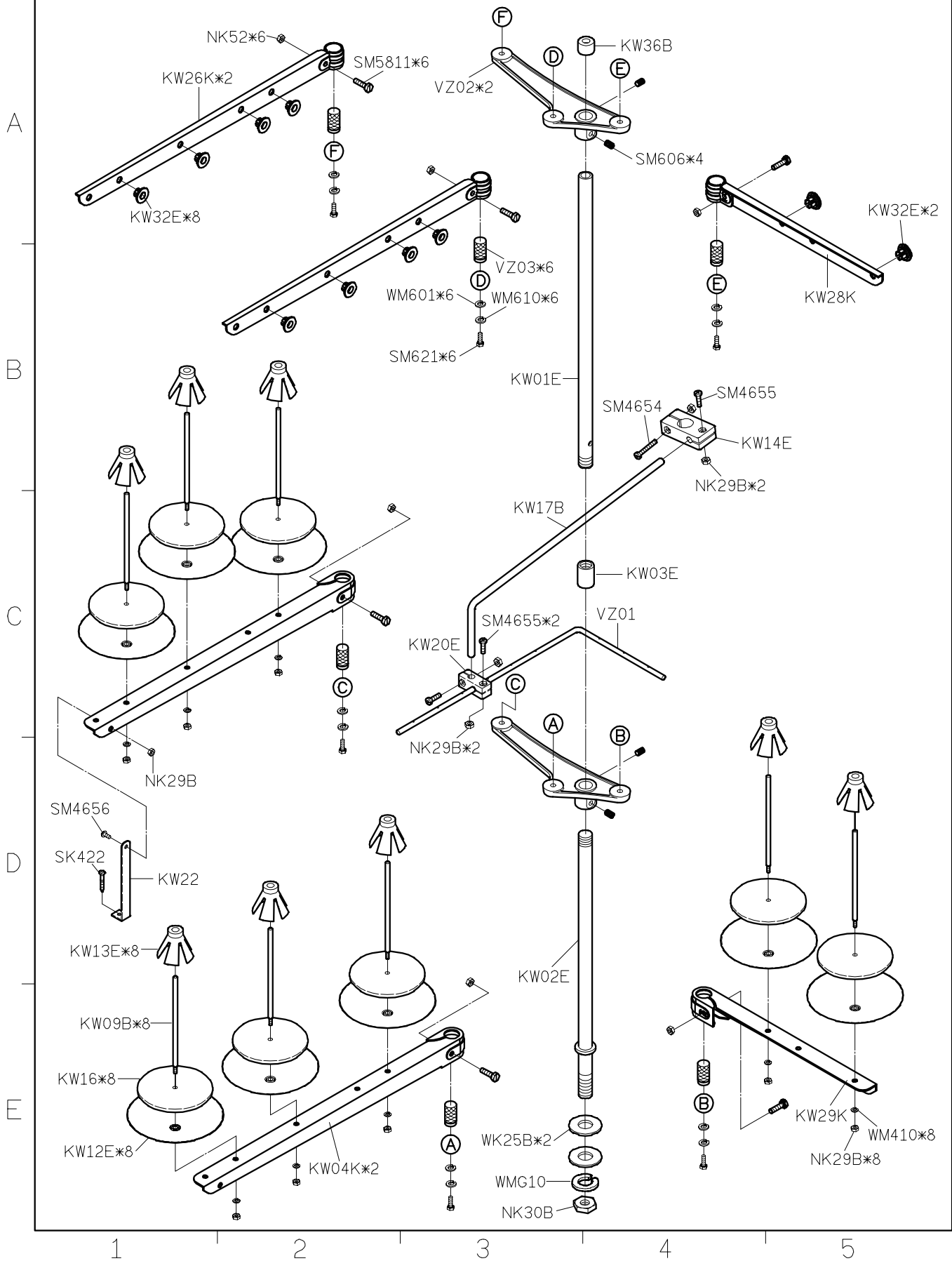

SIRUBA PARTS LIST	Series	Parts Group	Subclass / Remark	Page
	VC008B	VZ	OPTION:VZ09-A (6~12 NEEDLE USE)	2/2
				Date
				2020/05/18

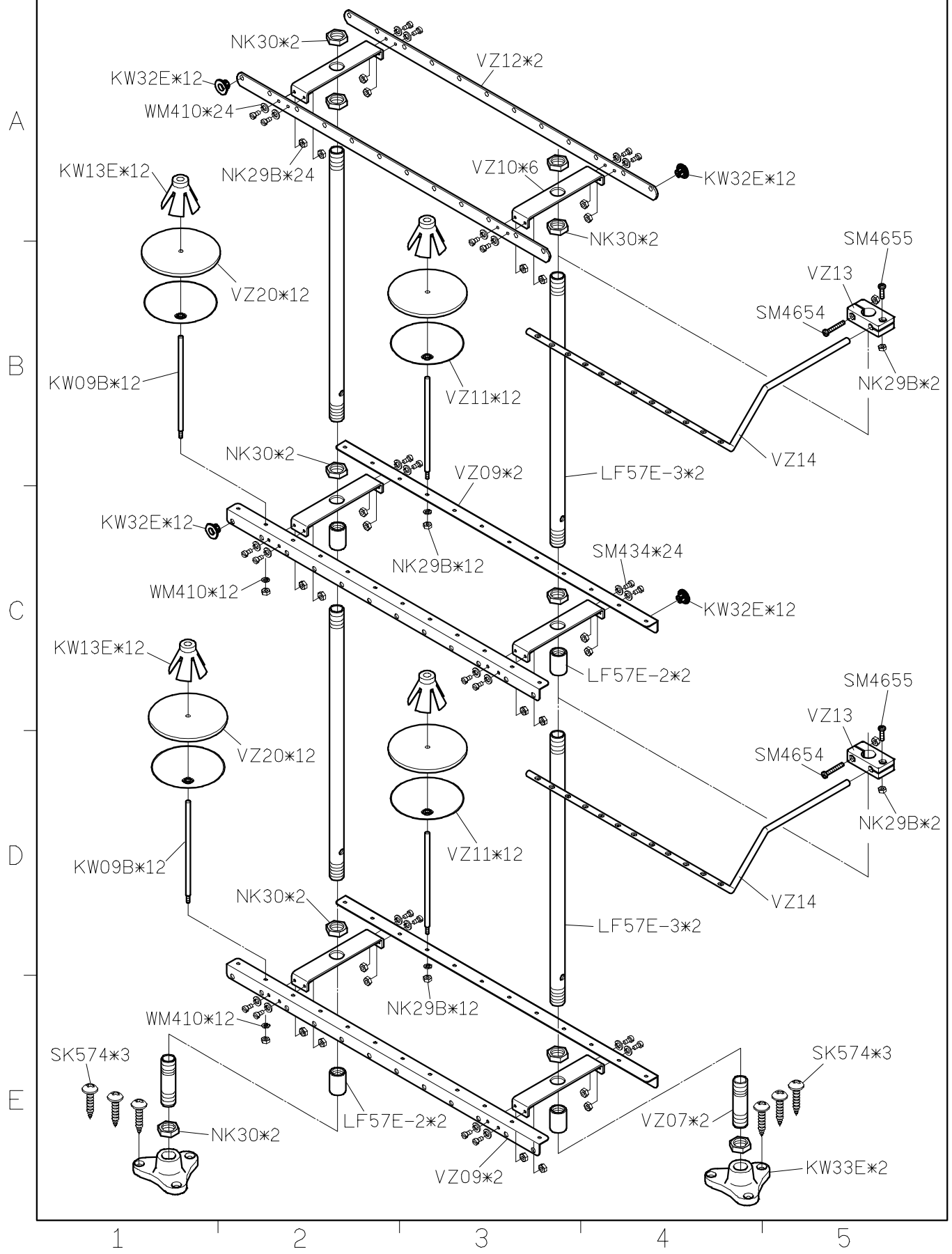

1. 當機器需要被淘汰與報廢時，有一些基本規則必須採納、遵守以保護環境及公眾健康。
  2. 所有的機器零組件必須依照下列分類來區分開：
    - (1) 所有護套、可伸縮軟管及塑膠或非金屬零件。
    - (2) 電器零件：開關、照明器具等。
    - (3) 絕緣材料：石棉、彈性/可伸縮橡膠片。
    - (4) 金屬：含鐵金屬、銅、青銅與黃銅、其他各種金屬。
  3. 以此方法，所有材質可以正確的淘汰，回收再利用或鎔解為可再使用或再處理而不至於危害環境。
1. When the machine needs to be eliminated and demolished, certain basic rules must be observed to protect the environment and public health.
  2. ALL machine components must be divided according to categories as the followings:
    - (1) All sheathes, flexible hosing and plastic or non-metal components.
    - (2) Electricity components: switches, or lighting components.
    - (3) Insulation materials: rock wool, and Flexible rubber strips.
    - (4) Metals: ferrous metals, copper, bronze and brass, various.
  3. In this way, all materials can be eliminated correctly, recycled, or melted down for reuse or disposed of so that they do not harm the environment.

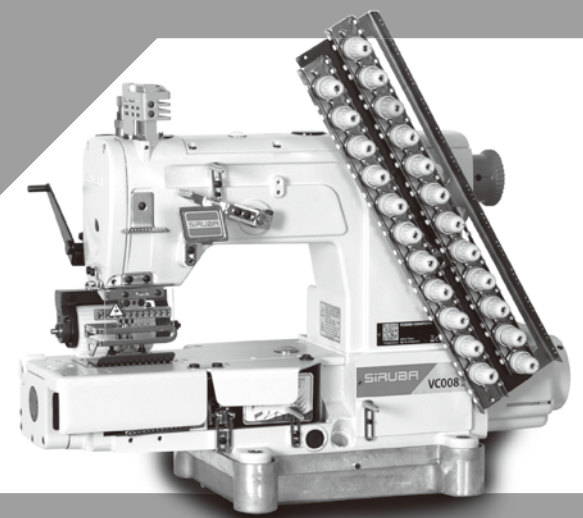

高林股份有限公司  
KAULIN MFG. CO., LTD.

由於對產品的改良及更新，本產品使用說明書中與零件圖之產品及外觀的修改恕不事先通知！  
The specification and/or appearances of the equipment described in this instruction book & parts list are subject to change because of modification which will without previous notice.  
VY201.JUN.2020