

INSTRUCTION FOR THE MAINTENANCE OPERATOR OF THE UNIT 3022 BHE

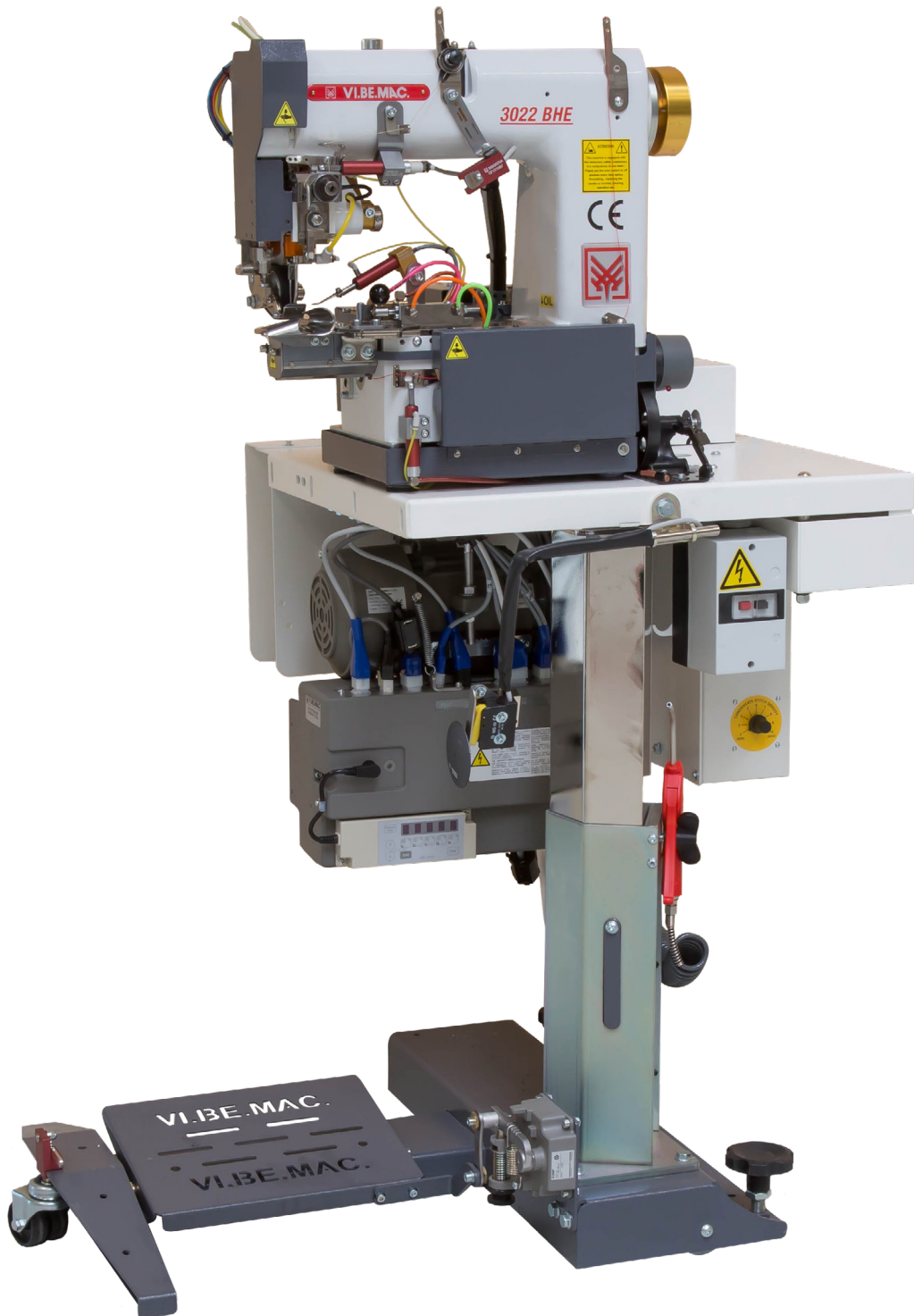

VI.BE.MAC. S.p.A.

Società soggetta a direzione e coordinamento di Jack Europe S.à.r.l.

Via Monte Pastello 7/i
37057 S.Giovanni LUPATOTO (VR)

Ph. (+39) 045 8778151

Fax. (+39) 045 8779024

Email: customercare@vbm-grp.com

www.vibemac.com

ORIGINAL INSTRUCTIONS

Thank you for choosing a machine manufactured by VI.BE.MAC. S.p.A.

This machine has been designed and built using state-of-the-art technologies and procedures to ensure the best reliability over time and, at the same time, to ensure maximum operator safety.

Carefully read and comply with all information in this manual for proper and safe operation of the machine. All documentation supplied with the machine - and in particular this manual - must be carefully preserved for future reference.



This publication or parts thereof may not be reproduced, stored in a storage machine, transmitted, transcribed or translated into any common or computer language, in any form or by any electronic, mechanical, magnetic, optical, chemical, manual or other means without express written authorization from VI.BE.MAC. S.p.A.

VI.BE.MAC. S.p.A. provides a guarantee with respect to the contents of this publication, with express prohibition to use this publication itself for other purposes of any commercial, practical, technical-scientific nature unrelated to operation of the machine to which it refers, for which this publication was drafted.

Guarantee on the correctness of information contained herein is provided on condition that all the provisions contained in this documentation are strictly observed by the machine user. Furthermore, VI.BE.MAC. S.p.A. reserves the right to revise this publication and to make changes to its contents without any obligation to notify any person or organization.

Said revised publications will be available upon request from VI.BE.MAC. S.p.A.

The original instructions manual was drafted in Italian.

Declaration of CE Conformity:
Translated Version

The company:

VI.BE.MAC. S.p.A.
Via Monte Pastello 7/i
37057 San Giovanni Lupatoto
VERONA - ITALIA
Tel. +39-045-8778151
Fax +39-045-8779024

In quality of manufacturer, declares under its responsibility that the product:

COMPANY: **VIBEMAC** MODEL: **3022 BHE**
SERIAL NUMBER: XXXXXXXX MANUFACTURED IN YEAR: 2018 two thousand and eighteen

DESCRIPTION: Trousers bottom hemming leg unit with step motor chainstich and lockstich

The present declaration has been issued according to machinery directive 2006/42/CE dated 17 May 2006 and to the following directive:

- Electromagnetic Compatibility 2004/108/CE

As required, CE mark is applied on the machine

PLACE AND DATE
SAN GIOVANNI LUPATOTO, 28/02/2018









CEO
Alberto Guerreschi

INDEX

1.	INTRODUCTION	7
1.1-	Storing the manual	7
2.	CONDITIONS OF USE	8
2.1-	Warranty conditions	8
3.	LIFTING AND TRANSPORT	9
4.	GENERAL FEATURES OF THE MACHINE.....	10
4.1-	INSTALLATION	10
4.2-	Flooring.....	10
4.3-	Dimension and weight.....	10
4.4-	Unit assembly	10
4.5-	Power supply	10
4.6-	Compressed air supply and consumption.....	10
4.7-	Lighting.....	10
4.8-	Work station	11
5.	DESCRIPTION OF SWITCHES AND COMMANDS	12
5.1-	Main switch.....	12
5.2-	Command pedal	12
5.3-	Sense of rotation	12
6.	THREADING PATH	13
6.1-	Threading path for chain stitch	13
6.2-	Threading path for lockstitch stitch	14
7.	LUBRICATION AND MAINTENANCE.....	15
8.	BHE MECHANICAL ADJUSTMENTS	17
8.1-	Chainstitch adjustments.....	17
8.1.1-	Needle bar height.....	17
8.1.2-	Looper timing	18
8.1.3-	Needle guard adjustment.....	18
8.1.4-	Looper regulation	19
8.1.5-	Upper and lower meeting point.....	20
8.1.6-	Spreader timing	21
8.2-	Lockstitch adjustments.....	24
8.2.1-	Rotary hook timing and needle bar high.....	24
9.	THREAD TRIMMING DEVICE.....	28
9.1-	Moving knife adjustment.....	29
9.2-	Fix knife adjustment	29
10.	NEEDLE BAR TRANSLATION MOVEMENT	32
10.1-	Needle position	33
11.	CHANGING FROM CHAINSTITCH TO LOCKSTICH	34
12.	STITCH LENGTH ADJUSTMENT	37
12.1-	Adjusting the puller transport	37
12.2-	Needle tip feeding adjustment.....	38
13.	FINAL CONDENSATE STITCHES	38
13.1-	Thread trimming output start angle	40

14.	 MITSUBISHI SERVOMOTOR	42
14.1-	Panel type GMFY	42
14.2-	Slow start speed setting	42
14.3-	Speed setting – slow start speed	43
14.4-	Sewing machine speed percentage setting	43
14.5-	Input / output test	44
15.	 PARAMETER LIST	47
15.1-	Reset	49
16.	 TROUBLESHOOTING GUIDE.....	49
17.	 ERROR LIST	51
18.	 ELECTRIC DIAGRAM.....	52
19.	 PNEUMATIC DIAGRAM	57
19.1-	Technical Pneumatic Diagram	57
19.2-	Topografic Pneumatic Diagram	58

SAFETY SIGNALS

	<p>ELECTRICAL SHOCK DANGER: BEFORE OPENING THE COVER OR DOING THE OPERATION SWITCH OFF THE MAIN POWER</p>
	<p>MECHANISM MOOVING: BEFORE DOING THE OPERATION BE SURE THAT THE MACHINE IS STOPPED AND DISCONNECTED FROM MAIN SWITCH</p>
	<p>DANGER: BE SURE TO FOLLOW THE INSTRUCTION</p>
	<p>DANGER: THE TEMPERATURE WILL BE OVER 70C°-160F°</p>
	<p>DON'T REMOVE SAFETY PROTECTIONS</p>
	<p>DON'T LUBRIFICATE OR ADJUST WHILE MOVING</p>
	<p>TURN OFF THE MAIN SWITCH BEFORE WORKING ON THE MACHINE</p>
	<p>THE USE OF EAR PROTECTION IS MANDATORY</p>
	<p>IT IS MANDATORY TO USE THE GOGGLES</p>

1. INTRODUCTION

Proper and safe operation of the machine is only ensured if used in accordance with the information stated in this manual and, in general, in the documentation accompanying the machine. It is therefore imperative to carefully read and store all relevant documentation.

It is always necessary to ensure that all operators have fully understood the rules of use. The company is not responsible for any damages to persons or property arising from improper use of the machine.

Do not remove or damage labels, writing, and warnings on parts of the machine. Should it be necessary to restore them, contact VI.BE.MAC. S.p.A.

VI.BE.MAC. S.p.A. disclaims any and all liability for a failure to observe the safety and prevention rules outlined in the various sections of this manual and for any damage caused by improper use.

The machine covered by this manual has been designed and manufactured in accordance with applicable laws and the state of the art valid at the time of delivery. It is the responsibility of the customer to make continuous adjustments to enable its constant compliance with the legal requirements and regulations in place at the installation site.

Any modification to the machine must be previously authorised by VI.BE.MAC. S.p.A.

All work on the machine (maintenance, adjustments, repairs, cleaning) must be carried out by appropriately trained personnel and as indicated in this manual.

1.1- Storing the manual

This instructions manual is an integral part of the machine and must be stored for any future reference. It is advisable to:

- Store the manual in an accessible place known to all operators which is protected from moisture and heat and protected from direct sunlight.
- Utilize the manual so as to avoid damaging all or part of its contents: do not remove, tear or modify parts of the manual for any reason.

In the event of sale or transfer of the machine to another person, this manual and its attachments must be delivered to the new user



!ATTENTION!



Please read this instruction manual carefully before using the machine. Anyone using the machine must be adequately informed about the parts of this instruction manual
For the operations to be carried out.

2. CONDITIONS OF USE

All operations performed in compliance with the below conditions are considered "normal":

- The user shall apply all directives of the following manual and "EU" directives.
- All safety regulations shall be respected by not removing guards or safety devices adopted by the manufacturer.
- Electrical power shall be constant and with maximum fluctuation of 10%.
- The unit must be connected to a 30ma differential.
- The unit must be connected to a grounding system to prevent disturbances or electric shock.
- The unit must be connected to an electrical circuit with separate neutral and grounding.
- The unit must operate in an environment with a temperature between 10°C and 40°C.
- No water or other liquids shall enter into the motor.
- No water or other liquids shall enter into the control board, the solenoid valves or the cylinders.
- The unit shall not be used in environments where explosive gases, dust or oil vapors are present.
- The unit shall be used in a place protected from atmospheric agents.
- The unit shall not be connected to a compressed air system with water or other liquids inside the circuit.
- The unit shall have a minimum pressure inside it of 5,5 constant bars.
- The unit shall be positioned at a maximum height of 1000 meters above sea level.
- The unit shall be installed on a level floor with no slope.
- Installation of the machine and its special maintenance shall be carried out by qualified personnel.

The manufacturer rejects any responsibility/damage caused by the machine to property or people in the event that:

- Installation of the machine has not been carried out by qualified personnel
- Any repairs to the unit have not been carried out by qualified personnel
- Electrical power is not constant or does not correspond to the required characteristics
- Grounding has not been connected or there are electronic disturbances present in the electrical system
- The unit has been subject to serious deficiencies in required maintenance
- Non-original or non-model-specific spare parts have been used
- Total or partial non-compliance with instructions by the user has occurred
- Rain or snow has come into contact with the unit

The following must absolutely never occur:

- Removal of guards or safety devices from their positions, making the machine dangerous for the user
- Removal of the eye-protection mirror without providing the user with protective eye-wear as per regulations
- Safety devices prepared by the manufacturer made inactive, making the machine dangerous for the user
- Machine modification without the manufacturer's authorization, making it dangerous for the operator
- Exceptional events

2.1- Warranty conditions

The machine is guaranteed for a period of twelve (12) months from the date of delivery.

The warranty includes the replacement of defective parts and the necessary labor, excluding travel expenses (food, lodging, etc.). Travel hours are charged.

In the case of replacement of parts only, these are delivered ex factory of VI.BE.MAC. S.p.A., or rather shipping costs are charged to the customer.

The warranty is valid only if the machine has been used correctly in accordance with the manufacturer's instructions and has not been tampered with, and shall be immediately terminated if any modifications and/or repairs not authorized by VI.BE.MAC. S.p.A. are carried out on the machine.

Parts subject to wear are not covered under the warranty.

The warranty shall also be terminated in the following cases:

- Failure to comply with payment conditions
- If proper maintenance is not carried out
- In case of removal of or tampering with plates and/or labels

VI.BE.MAC. S.p.A. shall not be liable for damage to the machine caused by improper use or malfunctions of other equipment connected to the machine itself.

3. **LIFTING AND TRANSPORT**

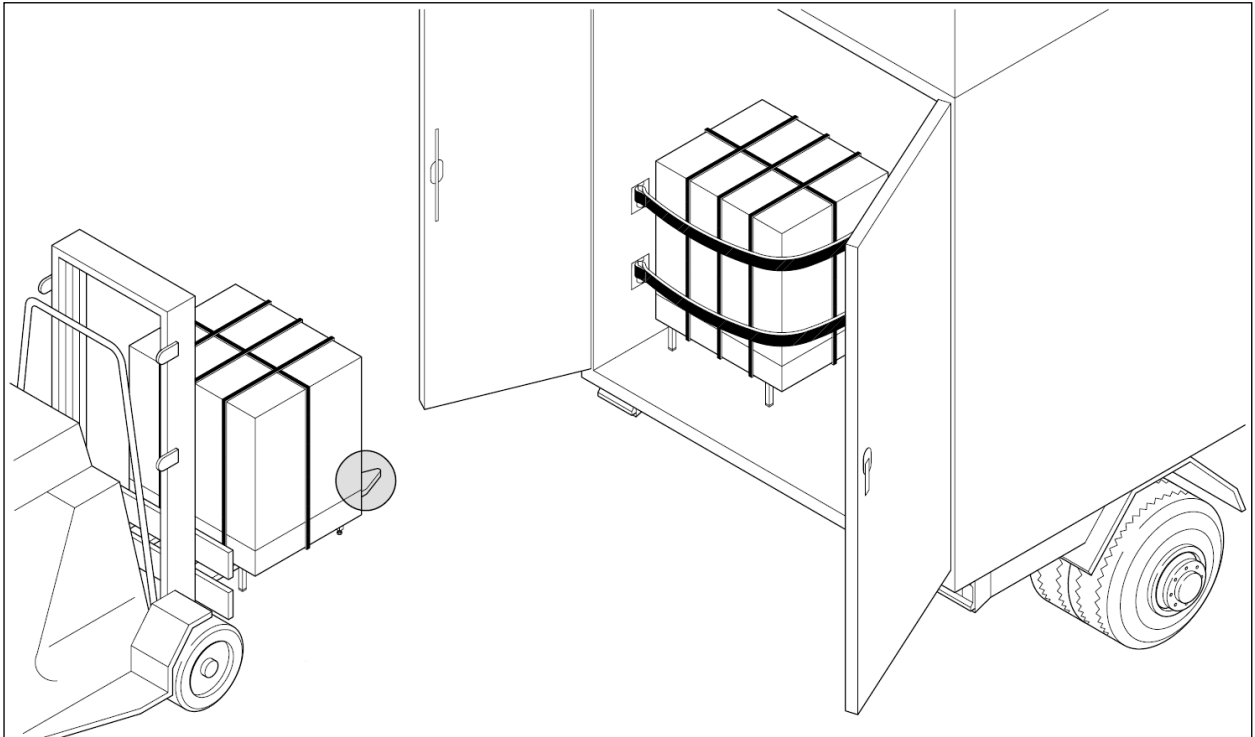

Make sure that during lifting the whole machine rests on the forklift forks.

Position the machine on the truck surly fixed with straps or balts that will insure the stability during the transport.

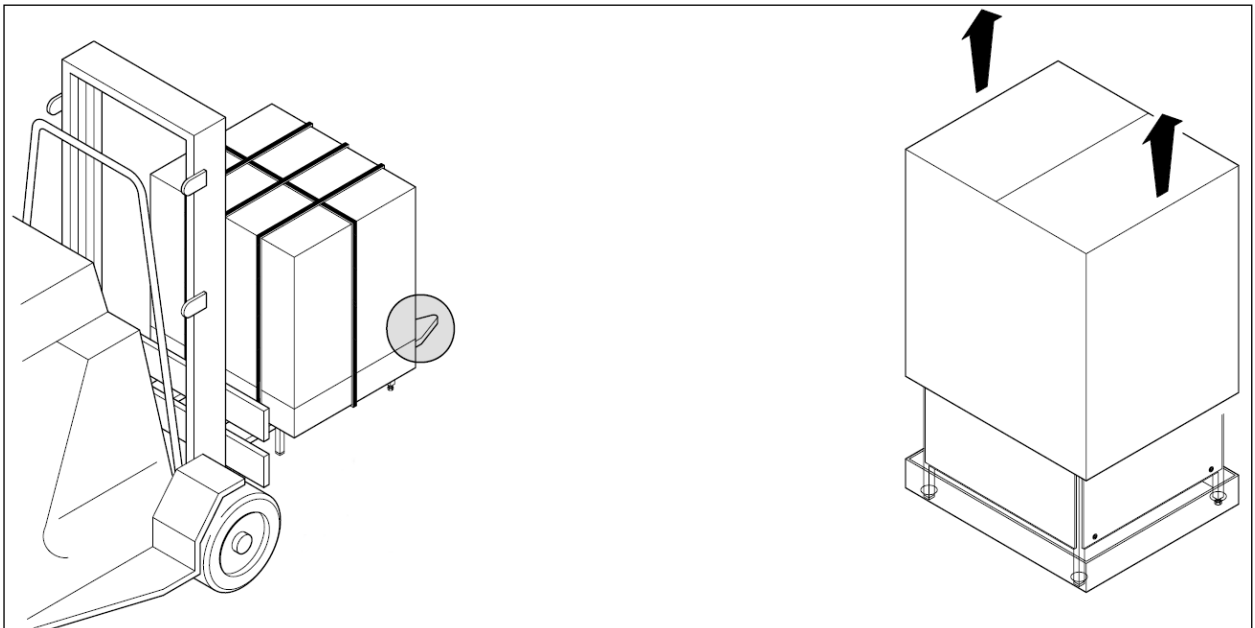

Make sure that during unloading the whole machine rests on the forklift forks. Place it on a hard flat surface repaired from weather.

Remove straps, and loosen the fixing screws, remove the top part of the packing box by pulling it upwards.



ATTENTION!
The unit must be unpacked on a flat surface and free from roughness.



4. GENERAL FEATURES OF THE MACHINE

The VI.BE.MAC. 3022BHE sewing machine is a single needle unit, equipped with VI.BE.MAC. sewing head, lock-stitch with a LARGE rotary hook, wide BOBBIN or chain-stitch with condensate stitches used to stitch the bottom hem of trousers. It has a pneumatic thread-cutting system, controlled electronically by the MITSUBISHI control box, has a fabric guide for the preparation, positioning and stitching of the bottom leg hem of jeans, casual trousers or overalls. The operator utilizes a foot pedal connected to the motor control box to activate the various operations required (Lifting of presser foot – Stitch Sewing Speed – Thread Cutting). The machine is easily adjusted for different sizes of hem, minimum width 9 mm and maximum 40 mm, as it has a feature that enables the guides to be changed quickly.

4.1- INSTALLATION

WARNING: THE INSTALLATION MUST BE PERFORMED ONLY BY SPECIALIZED PERSONS

We disclaim all responsibility for damages resulting from installation not complying with these instructions or from connecting the machine to power and utility lines not satisfying the necessary requirements. The machine should not be installed in environments in which explosive materials or substances are present. The unit must be installed on a flat surface.

4.2- Flooring

The user must provide compact, smooth and horizontal concrete floor for machine housing, suitable to support the weight of the machine and to ensure its stability.

4.3- Dimension and weight

Width: 97 cm Length: 55 cm Height: 110 cm Weight: 125 kg (circa)

4.4- Unit assembly

The unit is delivered to the customer per-assembled in its core parts. During transport and handling, the machine is disconnected from electrical and pneumatic power supplies, which are connected during installation by Vi.Be.Mac. personnel or persons authorized by them.

The securing and leveling of components making up the machine are carried out by authorized Vi.Be.Mac. personnel. In particular:

The unit is equipped with support points for positioning and leveling it on the floor.

4.5- Power supply

The supply voltage is 220V single-phase 50/60 Hz. Consumption is approx. 600 Watt (maximum fluctuations of $\pm 10\%$ are allowed).

4.6- Compressed air supply and consumption

The consumption is approx. 0,5 liters of air per cycle at a constant pressure of 5.5 bar. To enable/disable the unit pneumatically, use the main air valve from the right side of the unit. To open the sliding air valve and to enable the unit pneumatically, slide it backwards, while to close the sliding air valve and then remove the air from the unit, slide it forward.

4.7- Lighting

The user must ensure that lighting in the work areas is sufficient to allow a good view of operations and all machine components. In particular shadowed areas, annoying glares and stroboscopic effects must be avoided.

4.8- Work station

The operator works sitting down in front of the machine with a foot pedal speed control (1) at his feet, connected to a MITSUBISHI motor (2) and fixed with a hinge on the support. The folder (3) is attached to an adjustable support with a knee control (4) underneath the table. The main on/off switch (5) is underneath the table to the right on the support.

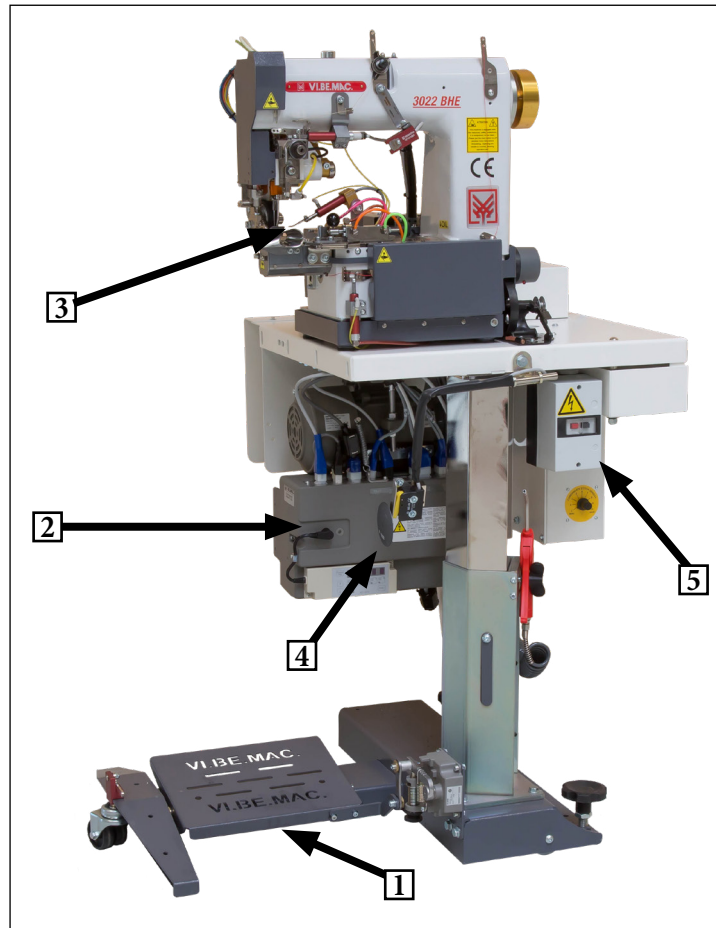



5. DESCRIPTION OF SWITCHES AND COMMANDS

In the unit 3022BHE there are the following switches:

5.1- Main switch

It is positioned under the table fixed to the central leg of the stand.

There are two buttons.

The left RED one is used to switch power OFF and as emergency.

The right BLACK one is used to turn power ON.

5.2- Command pedal

The pedal is positioned at the base of the leg, connected to the engine panel lever, and has three positions:

1. press forward to increase sewing speed;
2. neutral;
3. press back to:
 - raise the presser foot;
 - raise the puller;
 - open the trimmer;

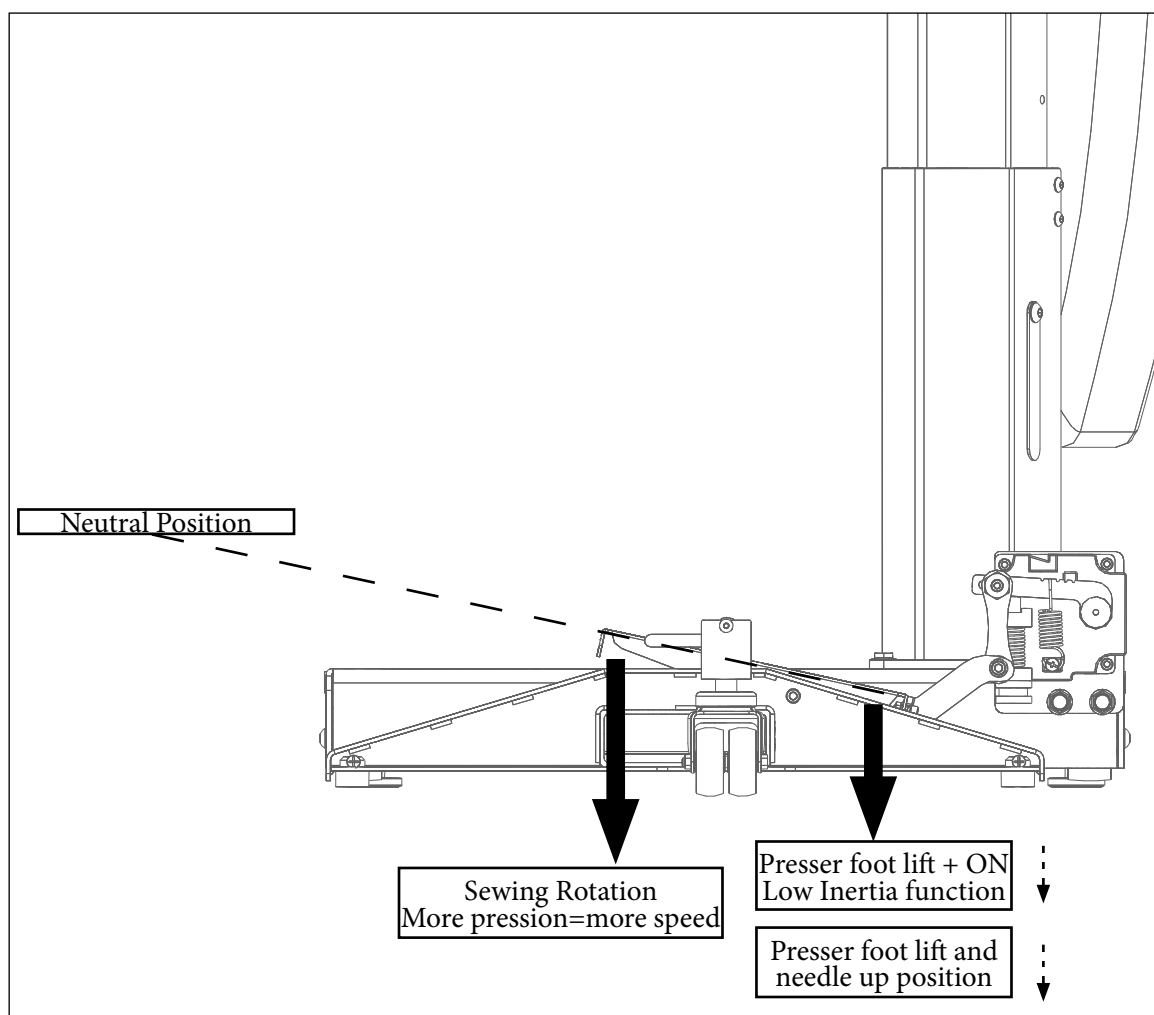

5.3- Sense of rotation

In the VI.BE.MAC. 3022 BHE unit the sense of rotation with Mitsubishi Motor is automatically inserted.

6. **THREADING PATH**

6.1- *Threading path for chain stitch*

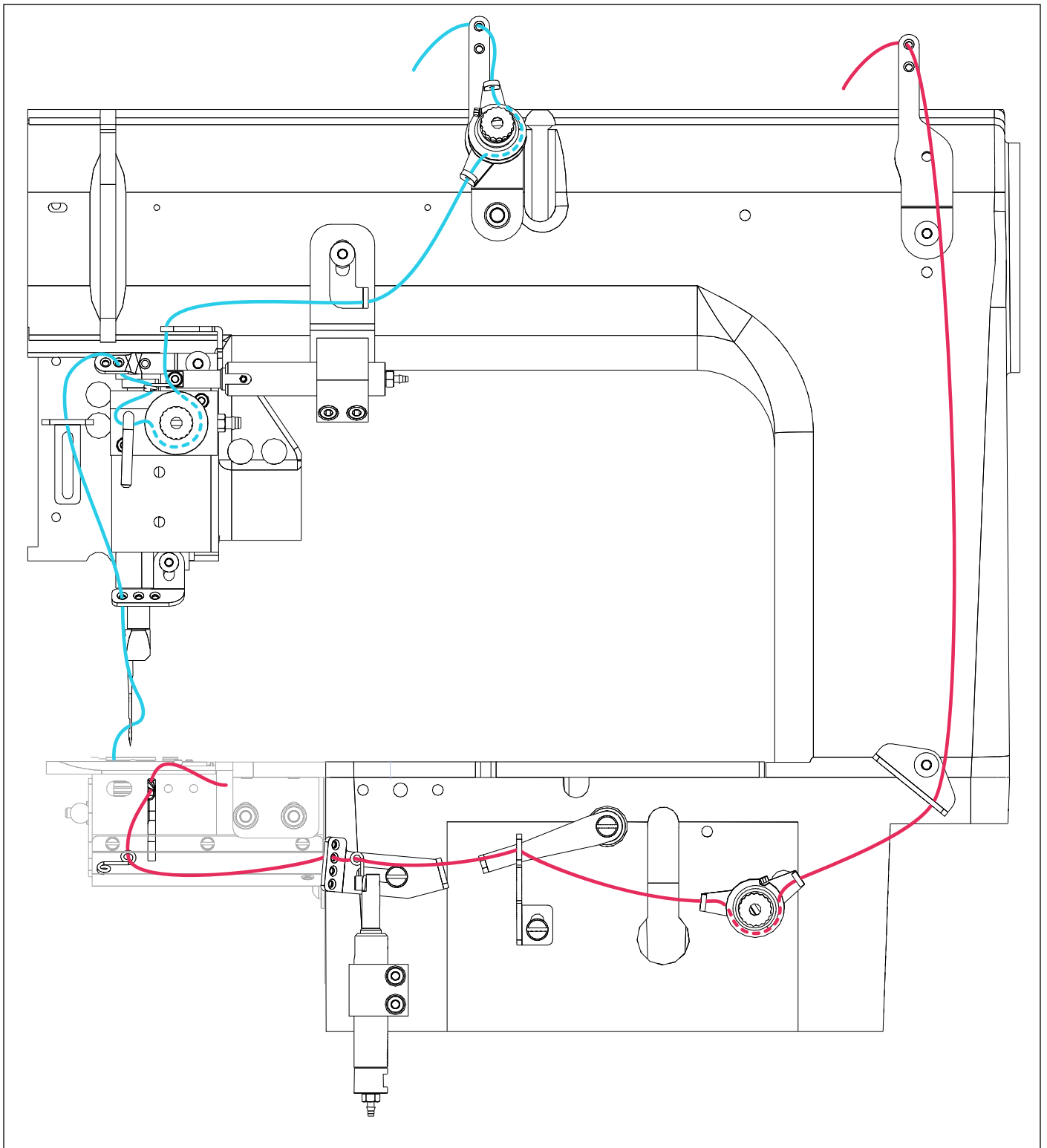

6.2- Threading path for lockstitch stitch

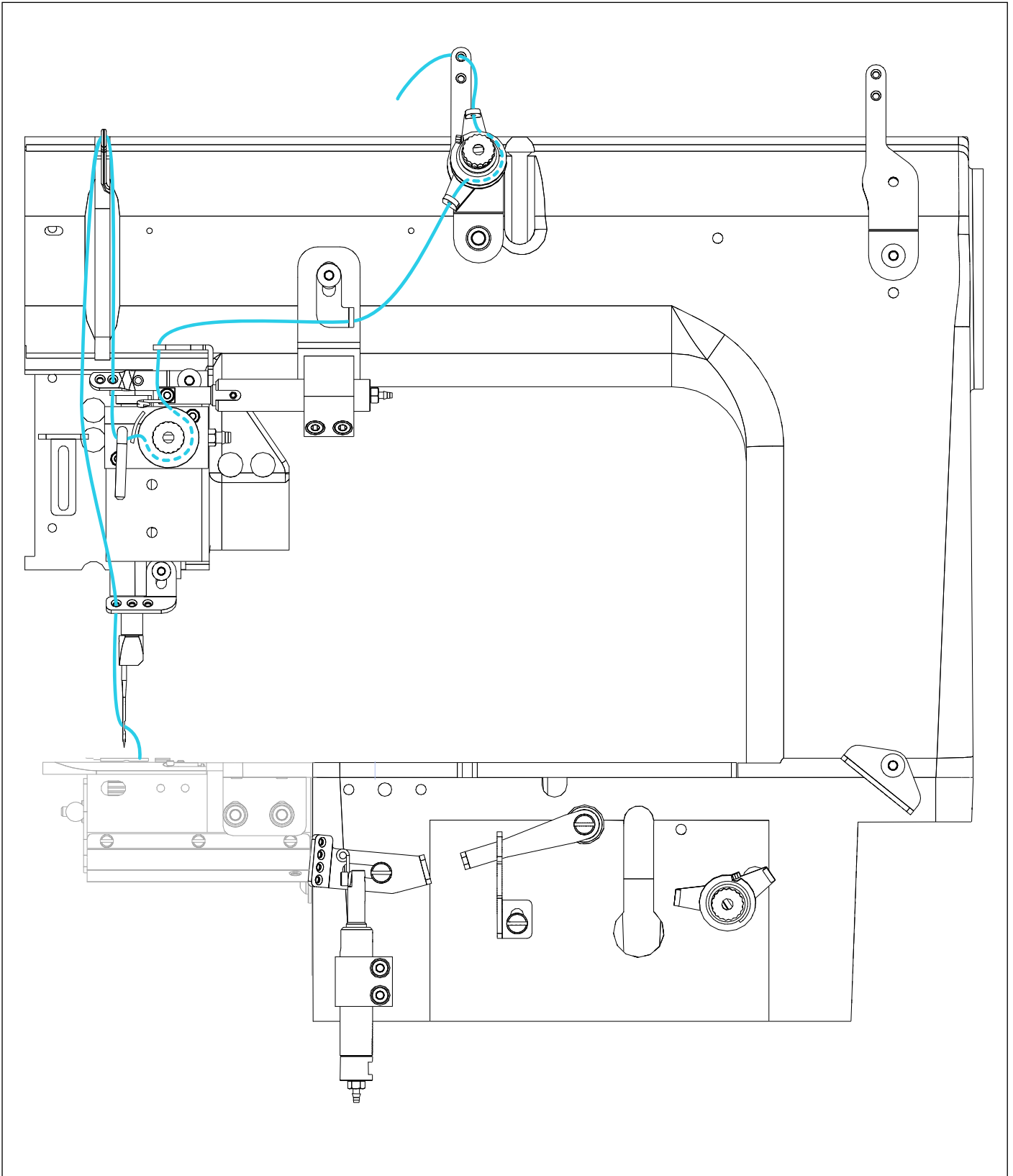

7. LUBRICATION AND MAINTENANCE

Every day before starting production to check the oil level in the 2 marked areas.

Clean the machine at least once a day with an air gun to remove dust from the sewing mechanisms.

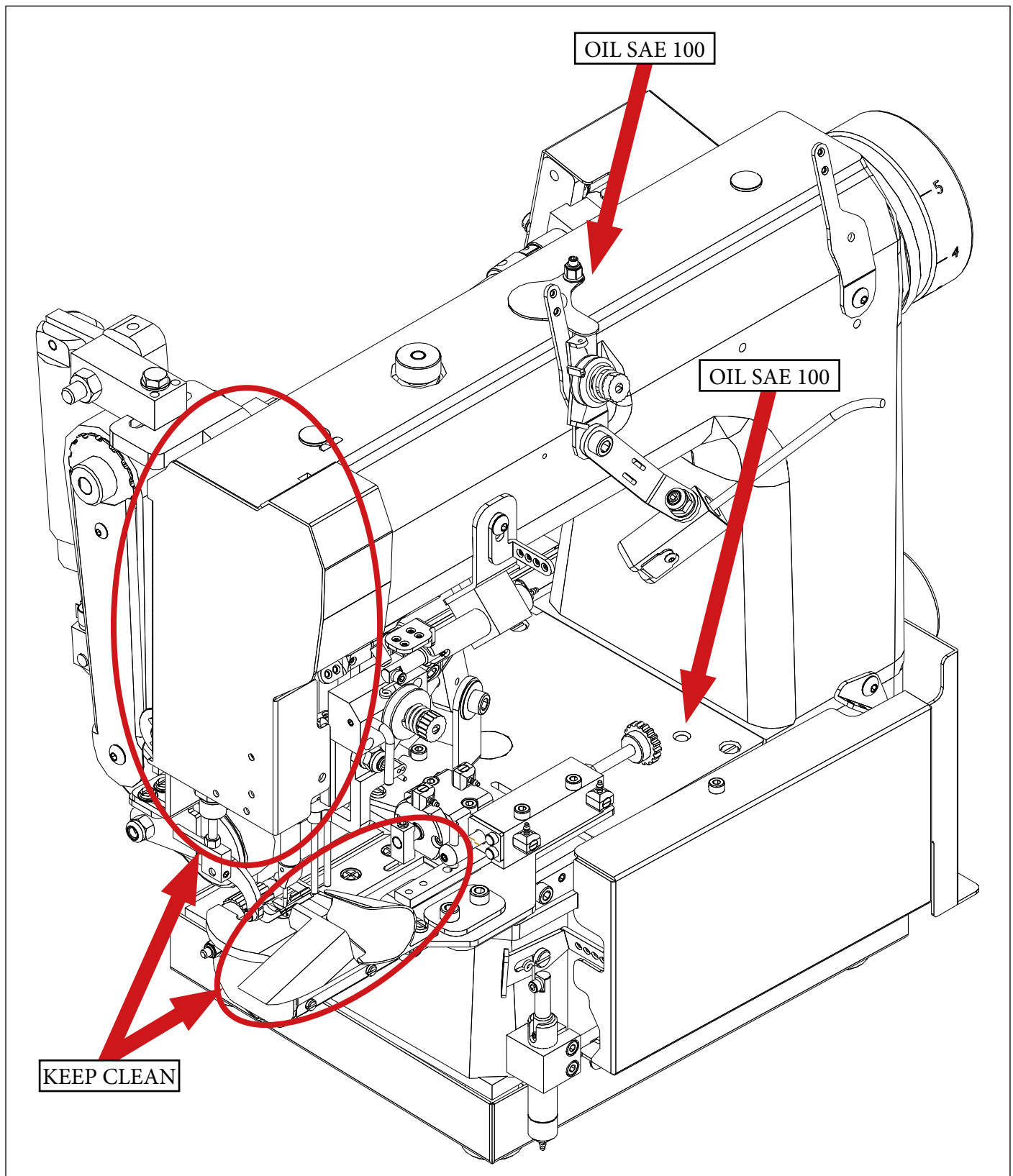

For the lockstitch option there is an extra oil tank for the rotary hook, equipped with a valve that open the oil tank only when the machine is sewing, to avoid the oil leakage. On the Oil valve the yellow tube is connected to the needle cooling yellow tube and the red tube is connected to the rotary hook.

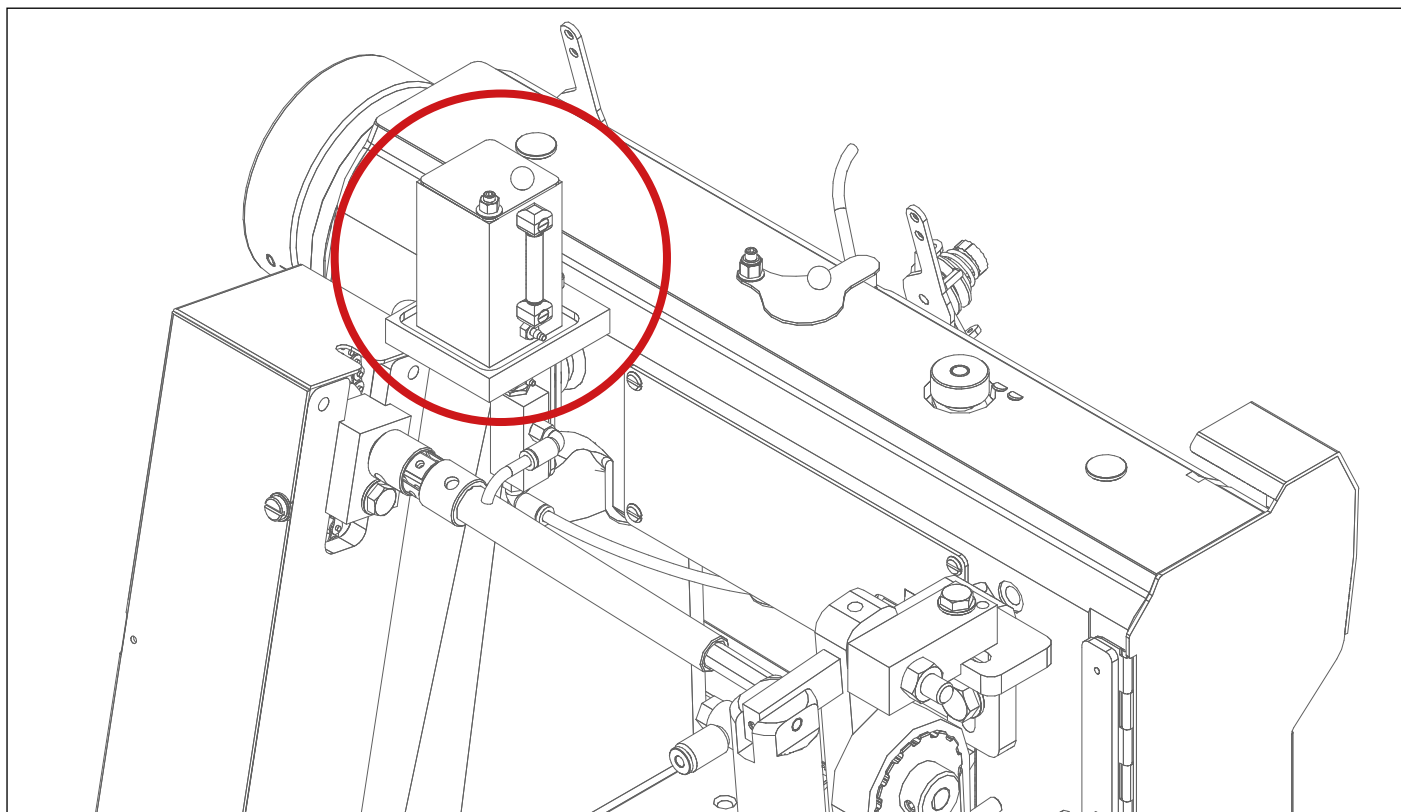

When the machine is running with the chainstitch option remove the red tube and put the tap in sted, bellow picture:

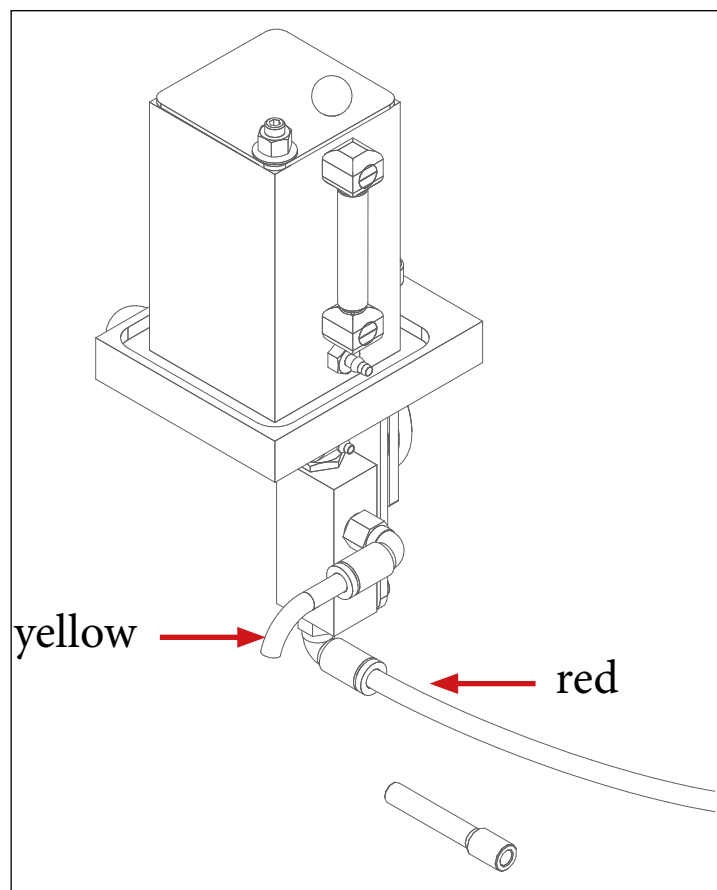

8. 3022 BHE MECHANICAL ADJUSTMENTS

The BHE unit uses a new sewing head expressly realized for this type of seam by VI.BE.MAC. S.p.A.

The operator **MUST** always switch off the machine, following procedure. **STOPPING THE MACHINE** before accessing any sewing unit.

Below is a list of the most common adjustments to be made to the machine in the event of malfunction.

Remember that only the personnel trained by VI.BE.MAC. S.p.A. is qualified for repairing the machine.

For any problem that can't be immediately solved or to require further information please contact immediately your nearest VI.BE.MAC. S.p.A. dealer or our Technical Office.

8.1- Chainstitch adjustments

8.1.1- Needle bar height

The unit BHE uses needles type 62x57 F-120

When the needle bar is in upper dead position, the distance between the needle point and the needle plate must be 11 mm.

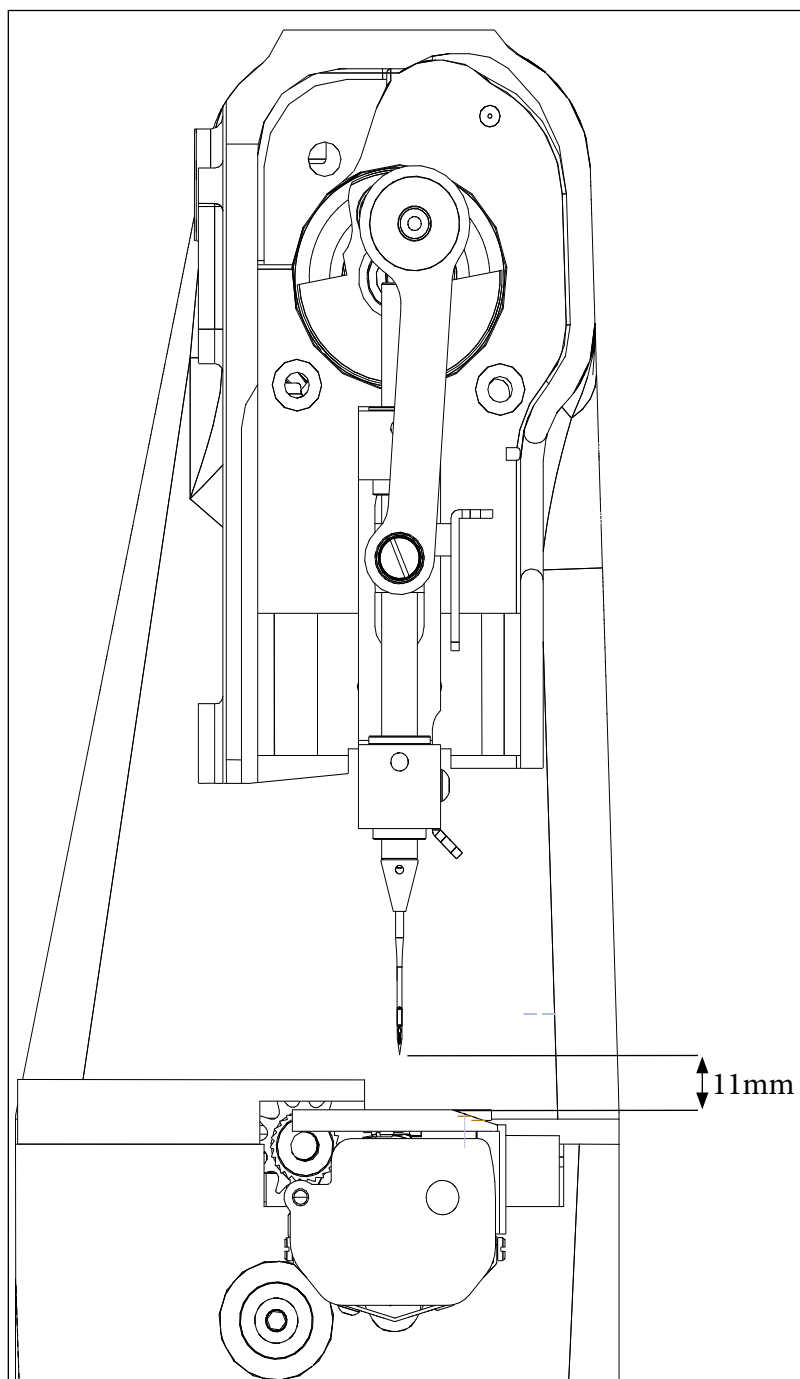

8.1.2- *Looper timing*

With the needle bar in lower dead position from the tip of the looper to the needle there must be 1.8mm (image 1). To adjust the looper position loosen the 2 screws (image 2) and set to correct position.

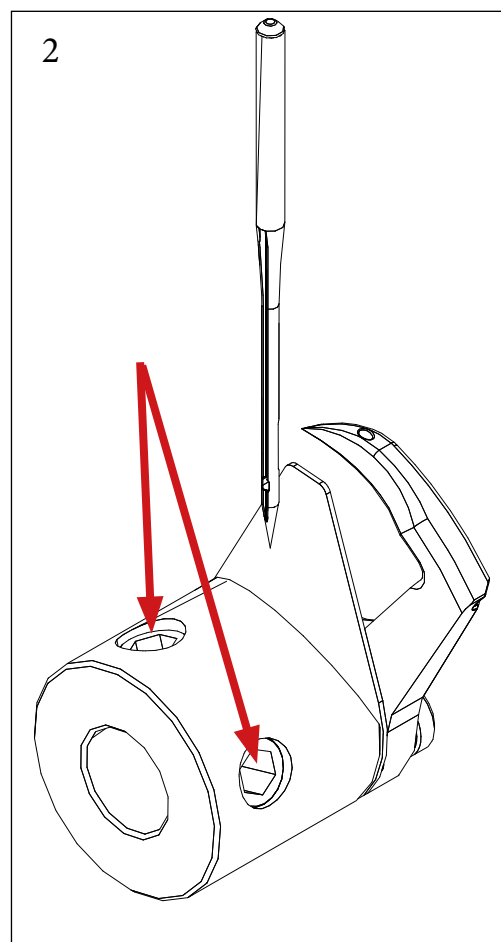
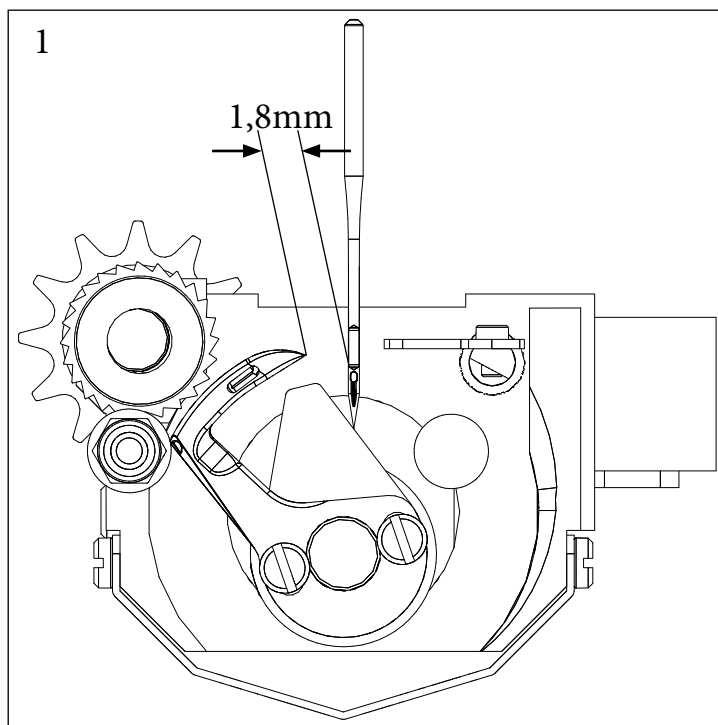

8.1.3- *Needle guard adjustment*

When the needle bar is in lower dead position the needle must have the thread hole covered from the needle guard for $\frac{1}{2}$ hole and the thread must pass freely (image 3) to adjust the position of the needle guard loosen screws A and B and adjust the position back or forward as need it.

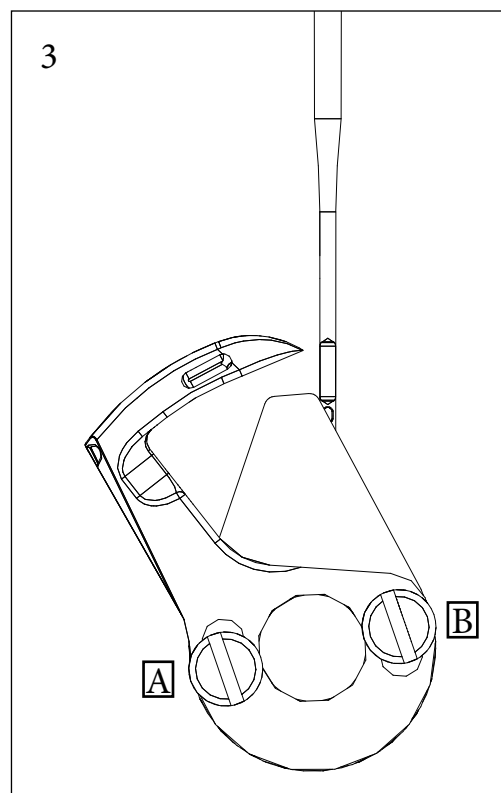

8.1.4- *Looper regulation*

To adjust the distance between the looper and the needle loosen the grab screw (as image) and move the bushing in or out as required.

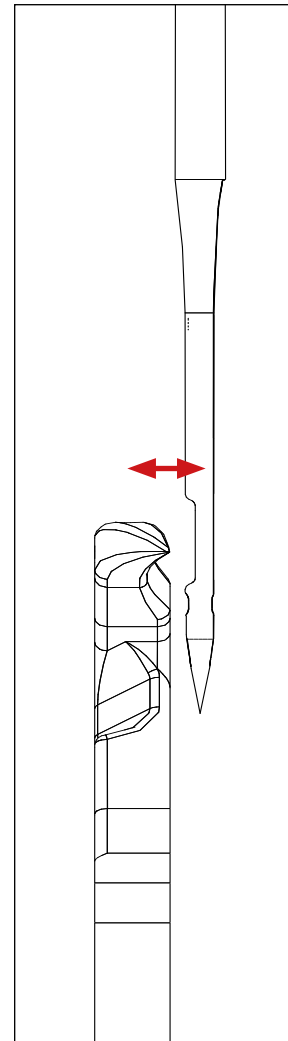
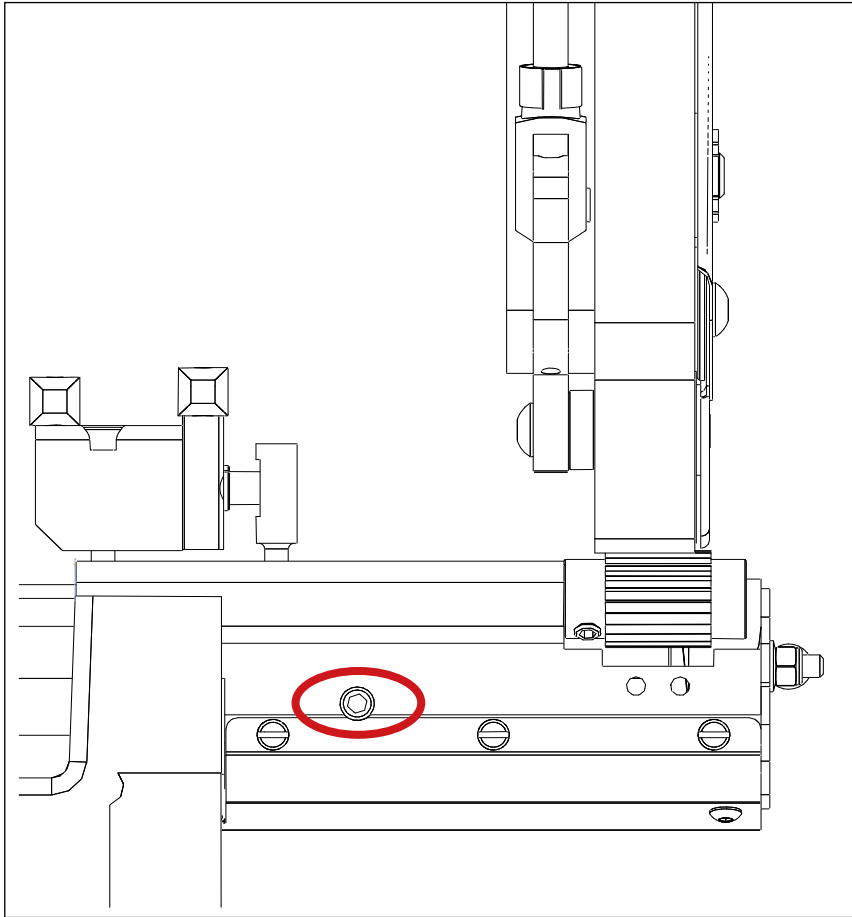

8.1.5- Upper and lower meeting point

For the looper timing the looper must pass in the same position of needle when going forward and backwards.

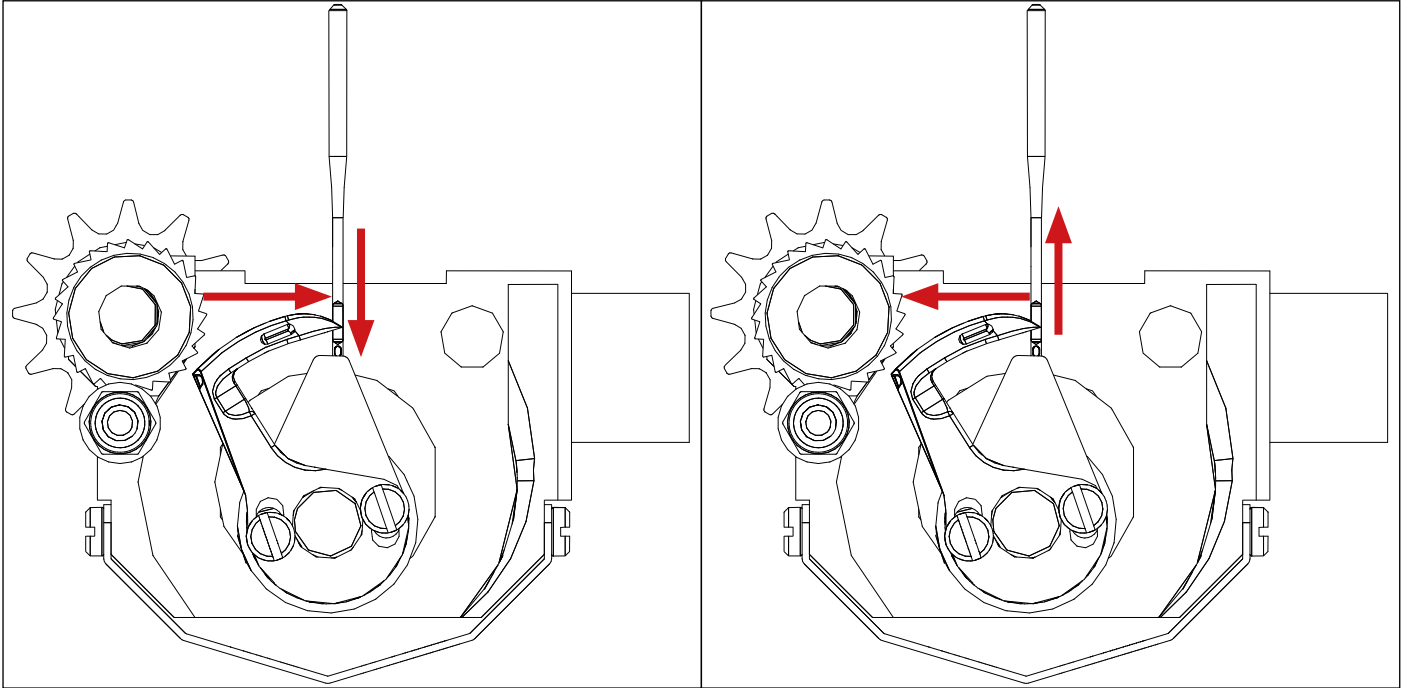

To adjust the meeting point loosen the 2 grab screws of the eccentric A and rotate clockwise or anticlockwise to reach the correct timing.

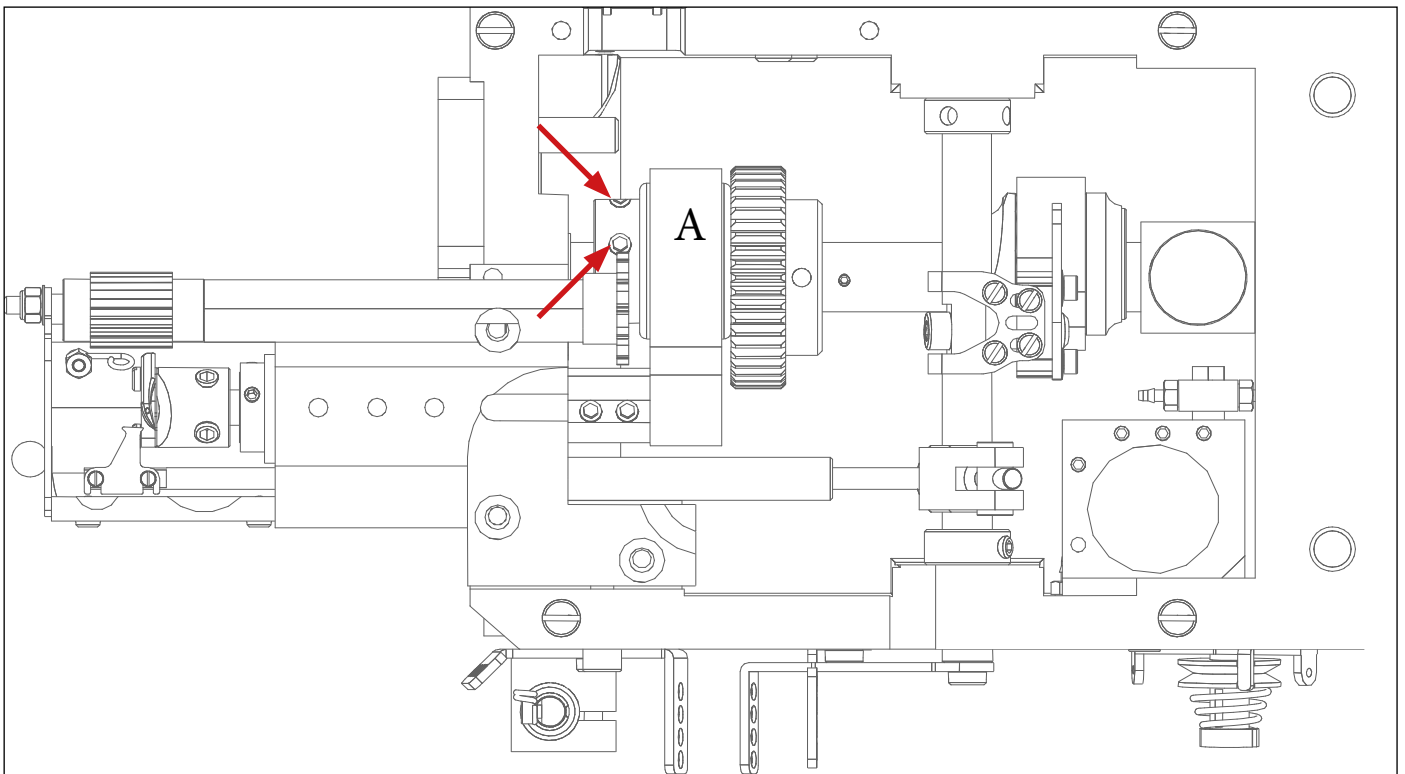

8.1.6- Spreader timing

The position of the spreader, with needle bar in higher dead point must be 1mm between spreader and looper, and the spreader must be totally back.

To adjust the spreader height loosen the grab screw (image 2) and regulate the spreader (image 1) and tighten again the grab screw (image 2)

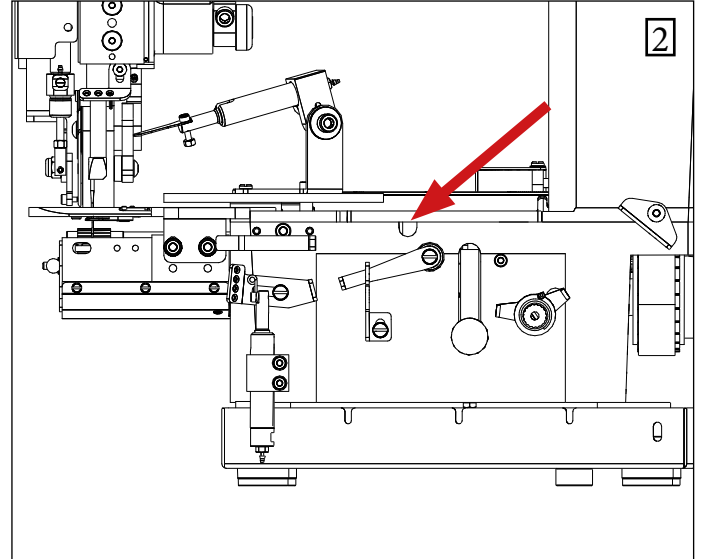
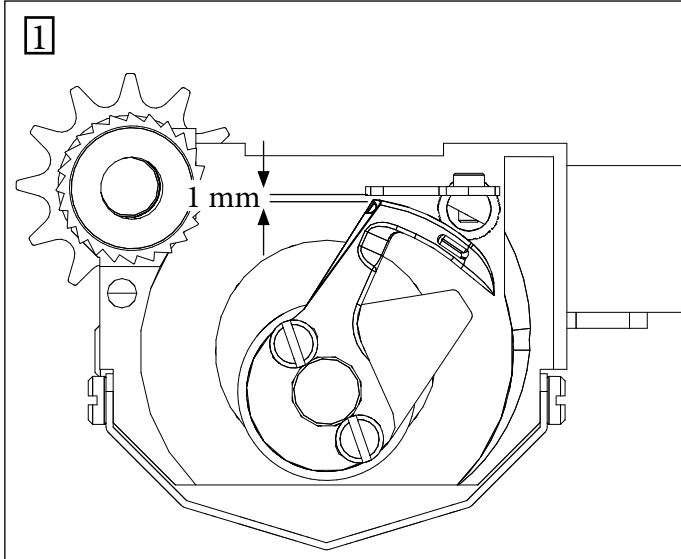

To regulate the distance of the spreader to the needle, loosen the screws (image 3) and adjust the position (totally back) and tighten the screws (image 3)

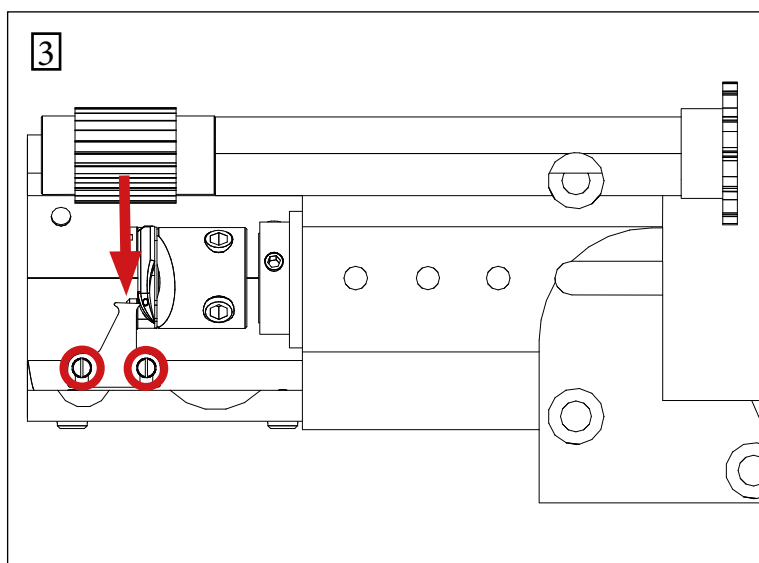

The spreader stroke must be adjusted, that the spreader is moving from the right side to the left side of the looper, and passing near to the looper hole.

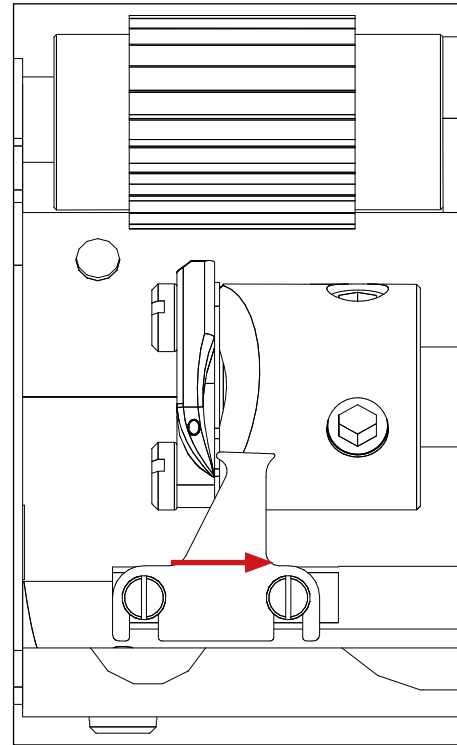
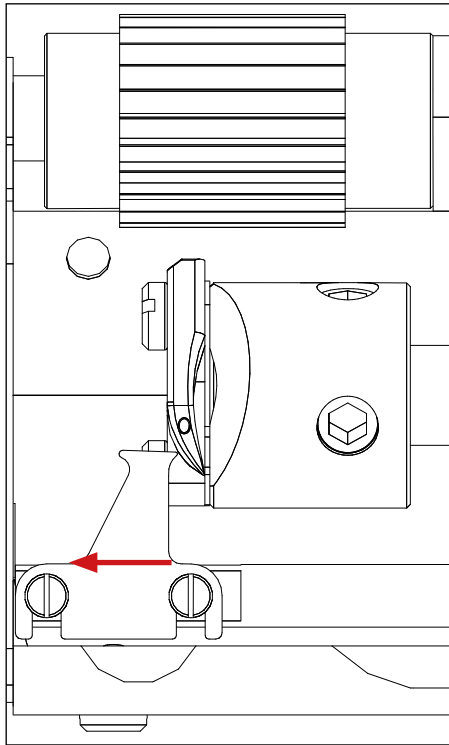

To adjust the spreader stroke length, loosen the screws on the eccentric (image 2) using the service hole from the image 1 then loose the 2 screws (image 3) and move the eccentric to have 4,5mm between the eccentric and the parallel shaft (image 3).

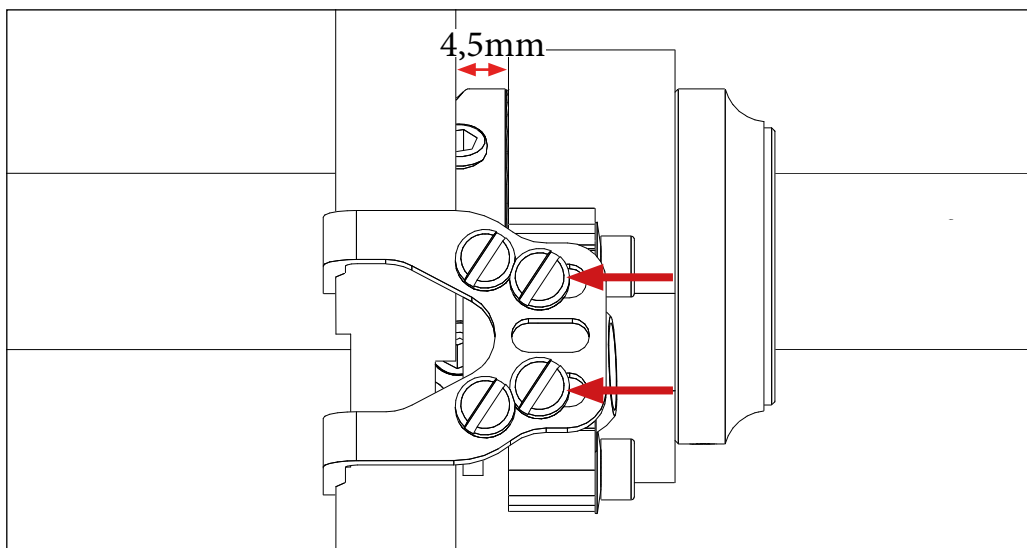
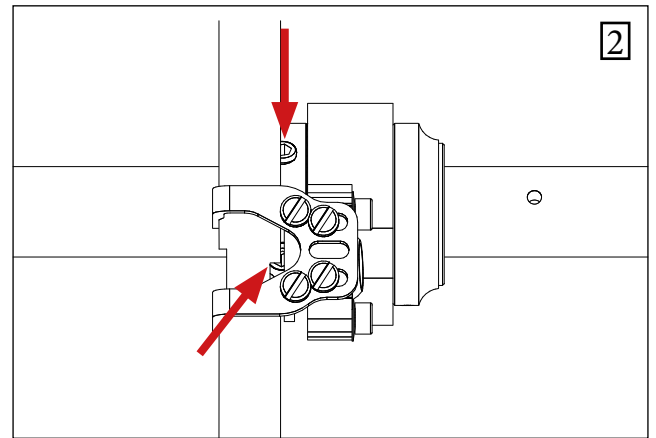
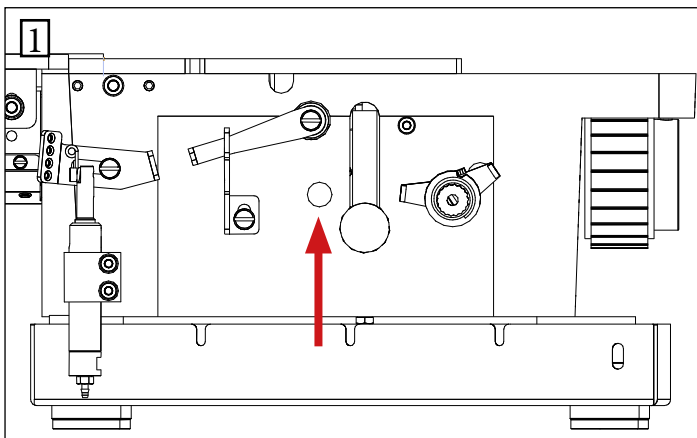

The correct adjustment of the spreader timing have to be done in this way:

When the needle bar is going down and the needle hole and the looper hole are matching (image 1), the spreader movement eccentric must have one screw facing the service hole from the casting and one screw facing up position (image 2).

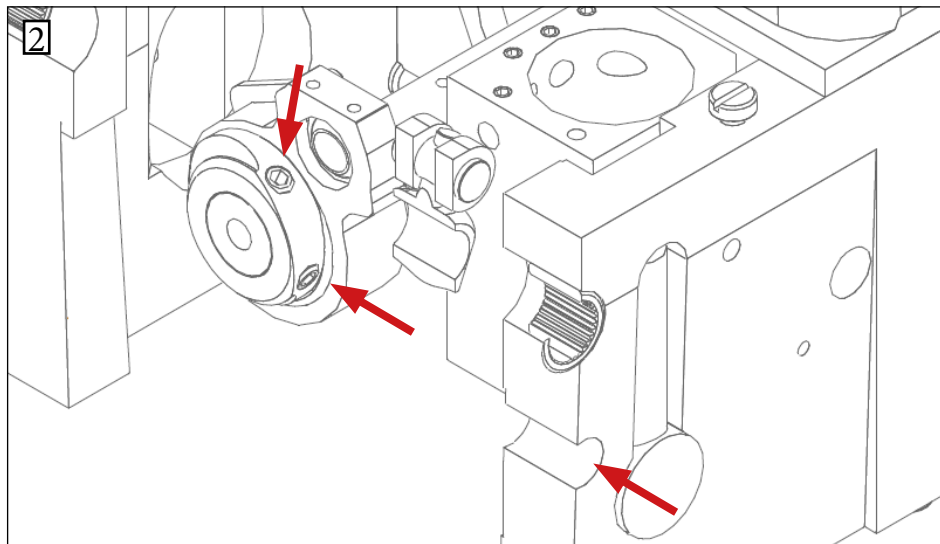
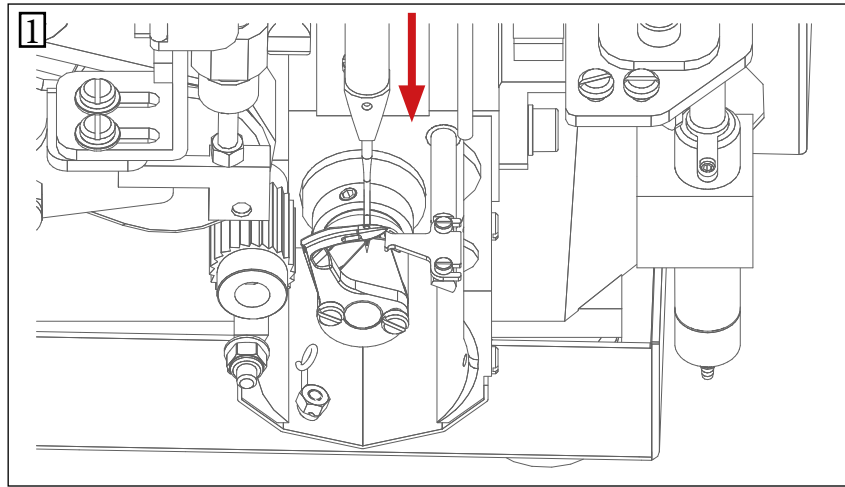

To perform this adjustment have to lose the eccentric grub screws and to rotate the eccentric.

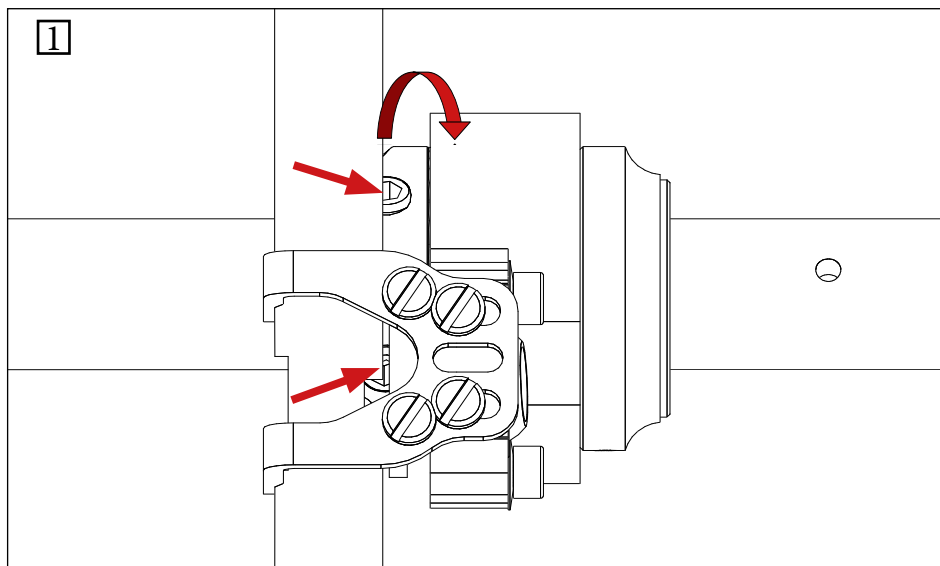

8.2- Lockstitch adjustments

8.2.1- Rotary hook timing and needle bar high

The unit has a rotary hook with large bobbin and use the follow 135x5 or 134 needle type.

Verify the Needle Bar height first of all, check that in the Lower Dead Point of it: the needle hole is for the upper 1/3 free and for the lower 2/3 closed from the Needle Guard. Test threading the Needle, on the Lower Dead Point the thread must be free if you push and pull it. Verify that the Needle Guard does not touch immediately the tip of the needle, but only the needle body must touches.

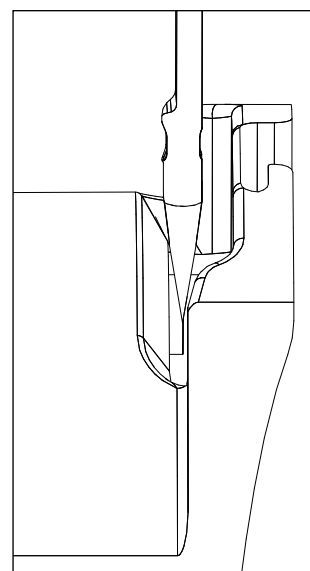
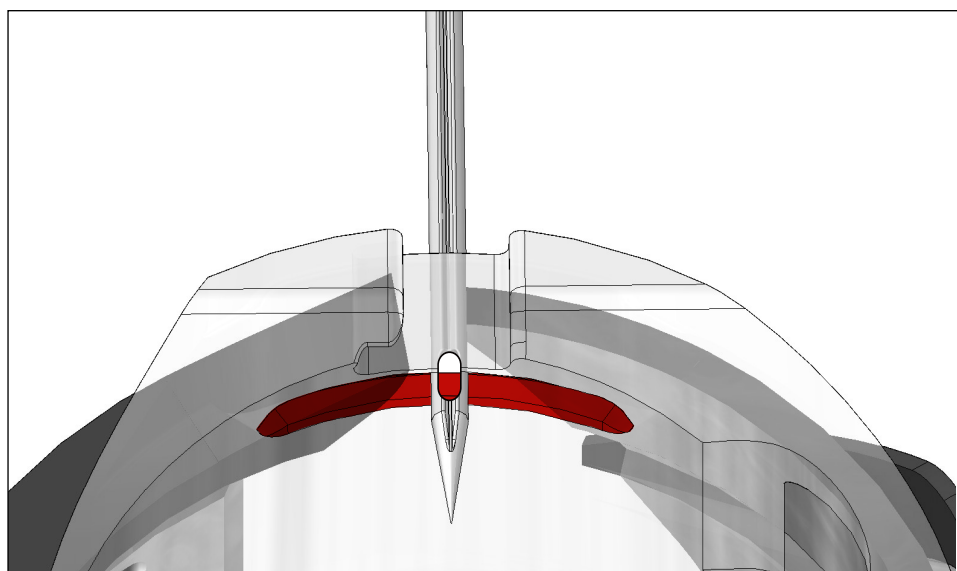

To adjust the needle bar height loosen and remove the screw as image 1 then loosen the grab screw that fixes the needle bar and adjust the height as image 2. Once adjusted the needle bar height tighten the fixing grab screw and re position the other screw.

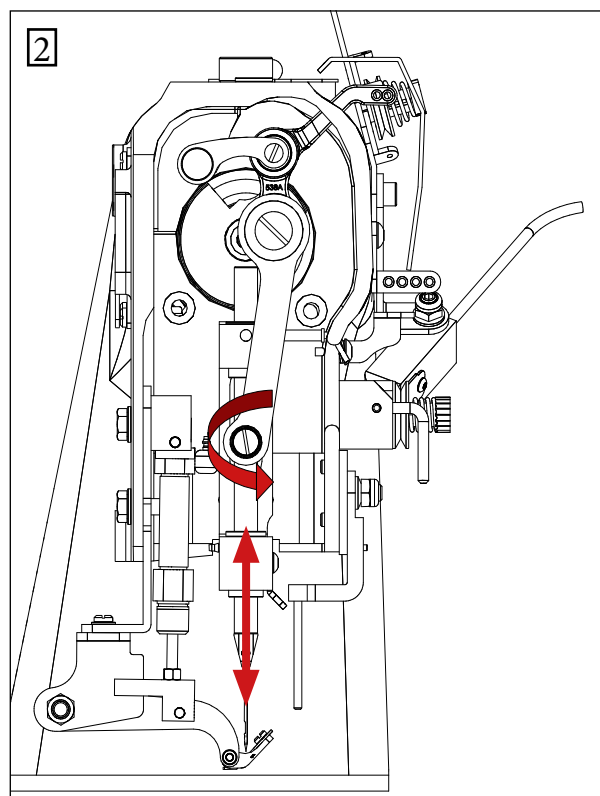
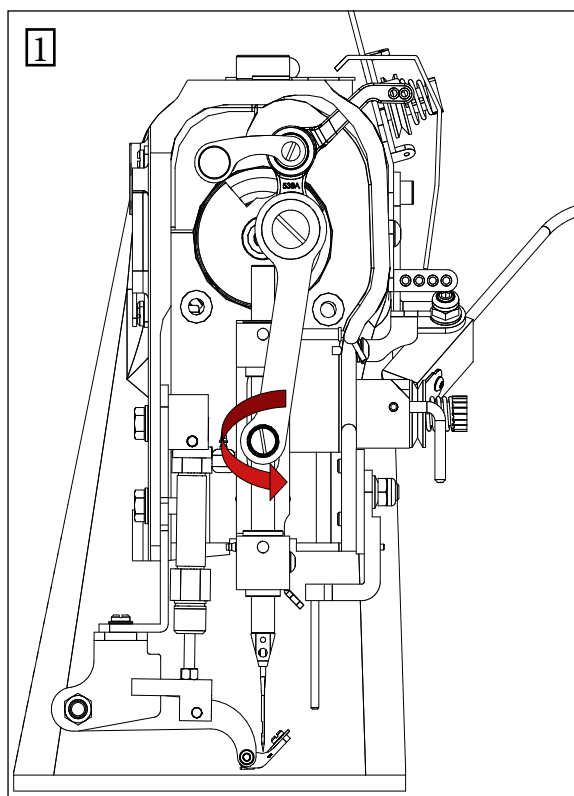

With needle bar in Lower Dead Point.

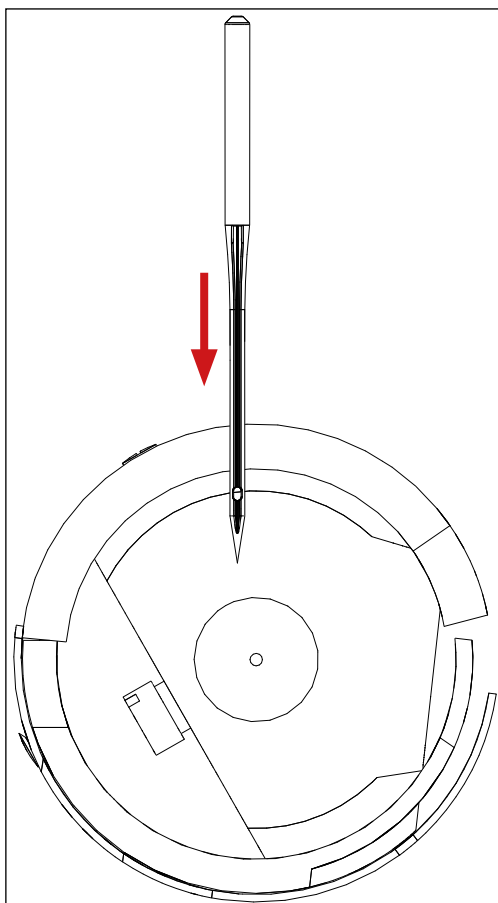

Rising the needle bar using the hand wheel of 1.8mm from the Lower dead position the hook should be in the phase point.

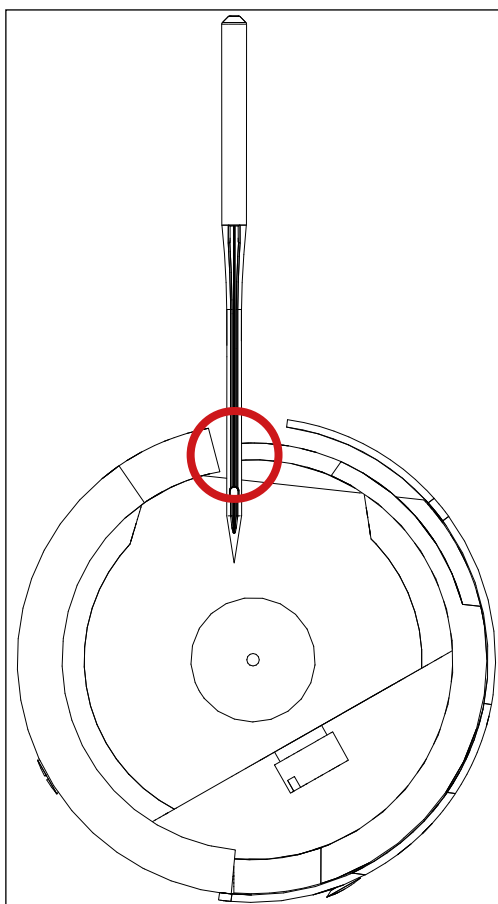

To adjust the hook timing loosen the 3 screws that fix it and rotate to obtain the correct timing.

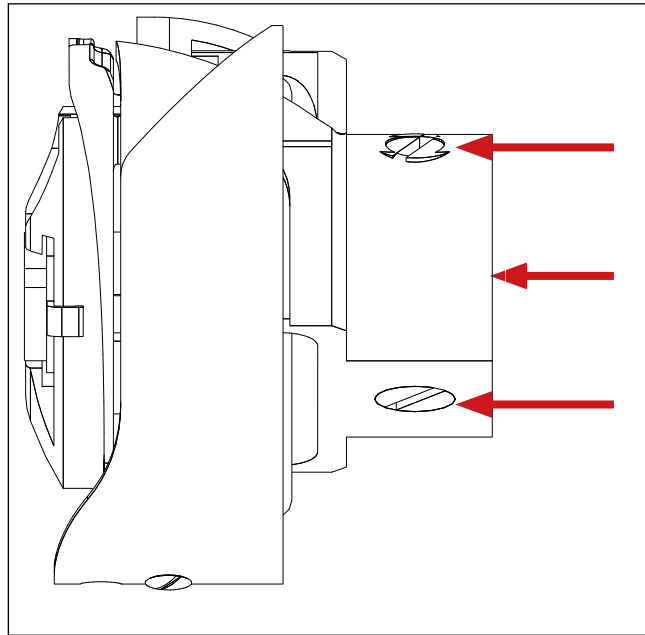

To adjust the distance between the hook and the needle:

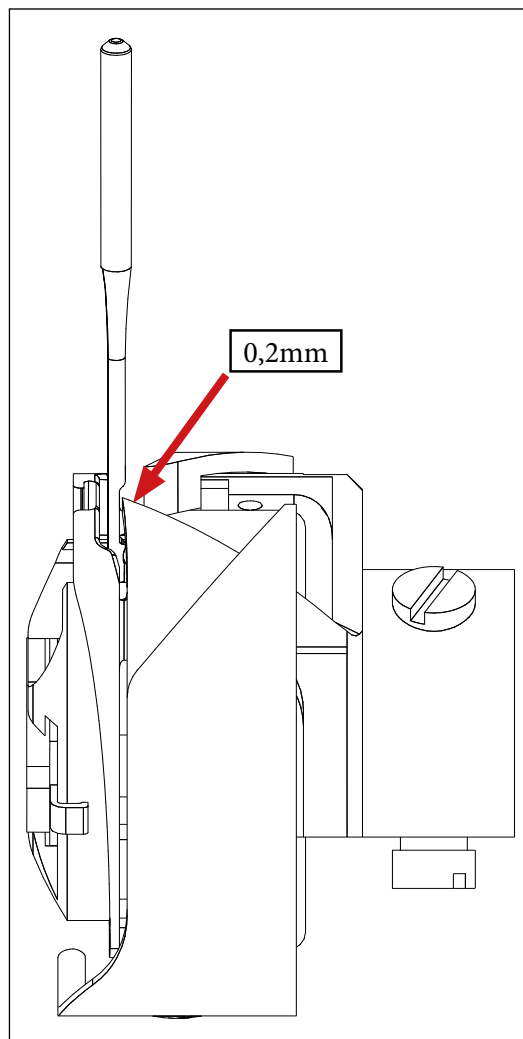

Loosen the grub screw.

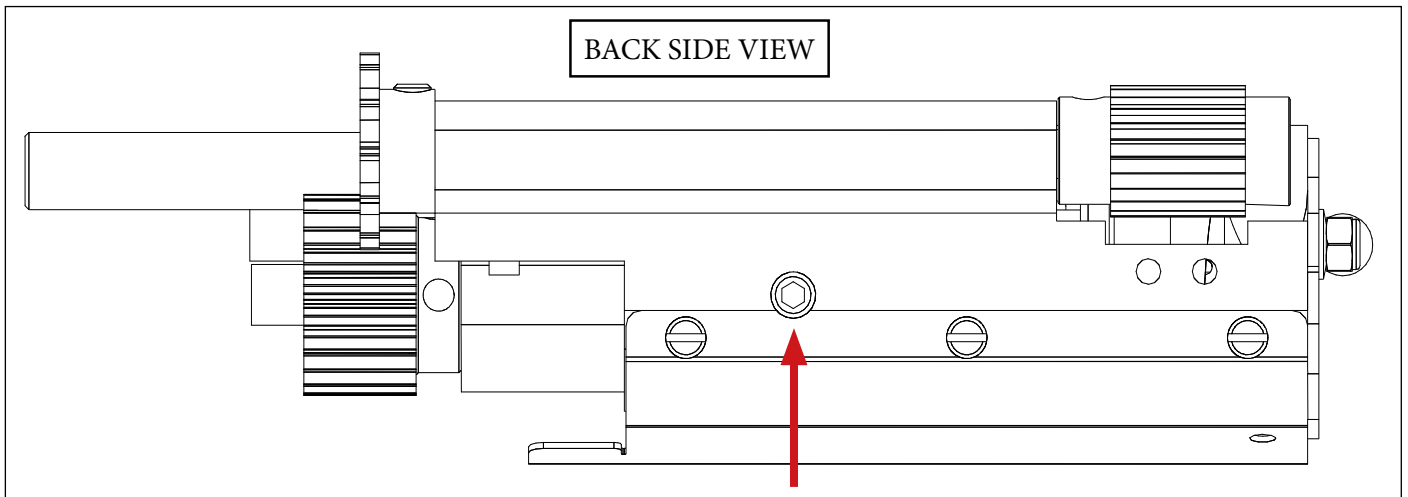

And move the hook block in or out as needed.

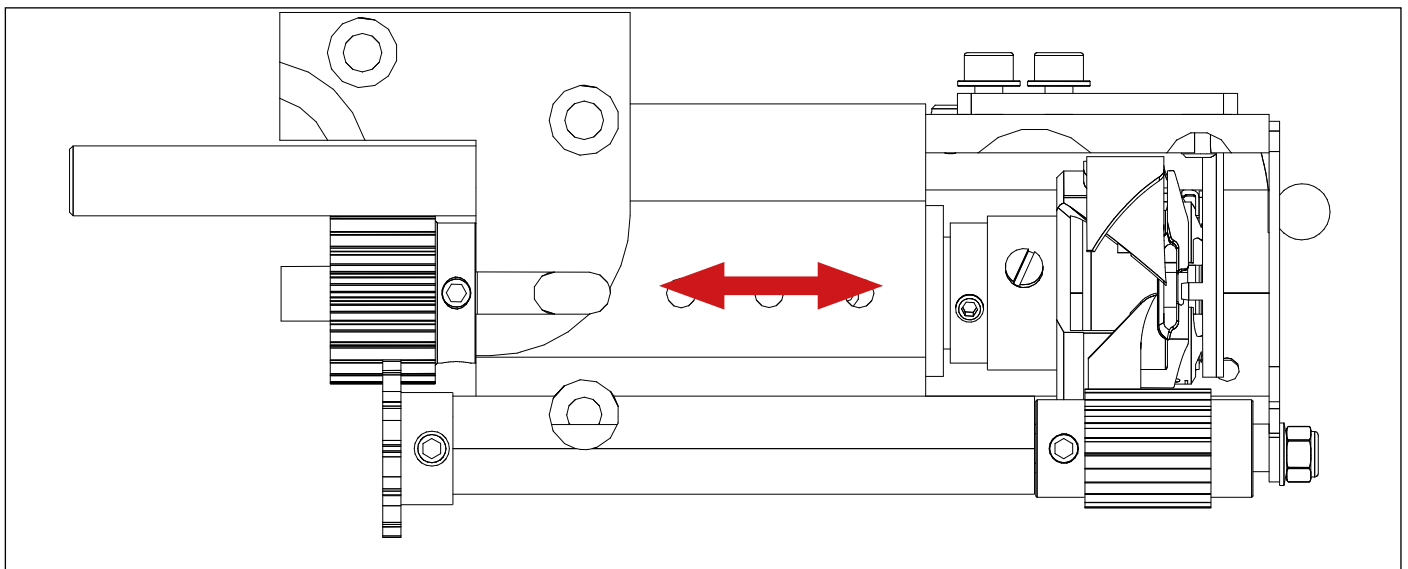

To adjust the position of the retaining finger, loosen the 2 screws and align perfectly as shown in the lower image, must be a distance between 1-1,5 mm.

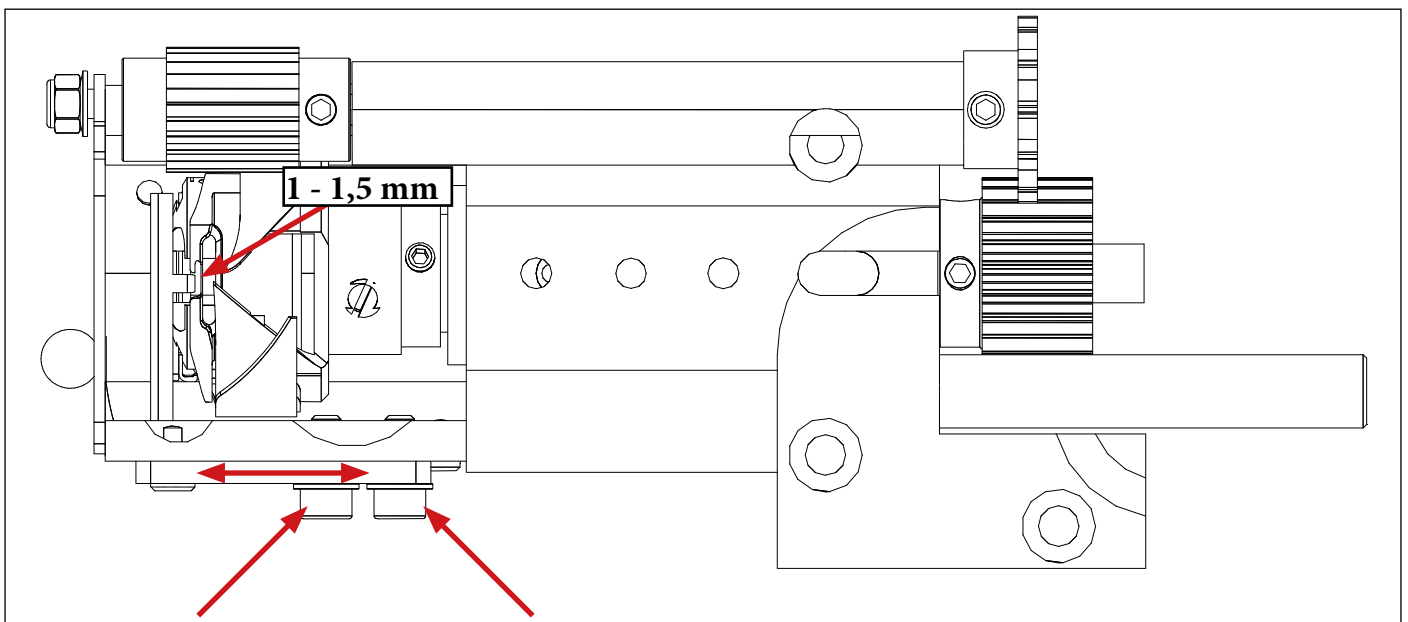

9. **THREAD TRIMMING DEVICE**

On the unit there is a pneumatic Threads Cutter device commanded by the GMFY Control Box. The Trimmer has not the possibility to change its position compare the loop stitch formation point. In this way it is fix on the Needle Plate and is really important that the needle entry in the middle of the Needle Hole.

On the Trimmer device there are just a few regulations:

- For the MOVABLE KNIFE the clearance between it and the NEEDLE PLATE.
- For the FIX KNIFE the possibility to adjust its position compare the MOVABLE KNIFE, and the PRESSURE in between them.

The unit 3022 BHE is already equipped with two plates prepared for chain stitch and lock stitch, differences between the chain stitch and the lockstich plates are the:

- The needle plates are different (picture 1 and picture 2)
- The moving knives are different (picture 3)

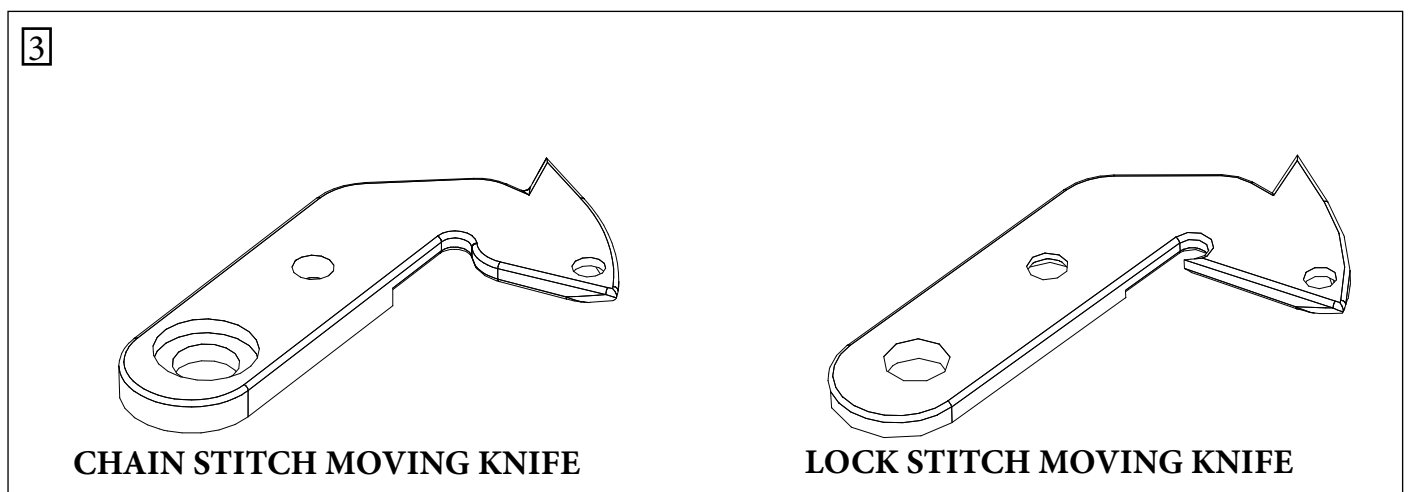
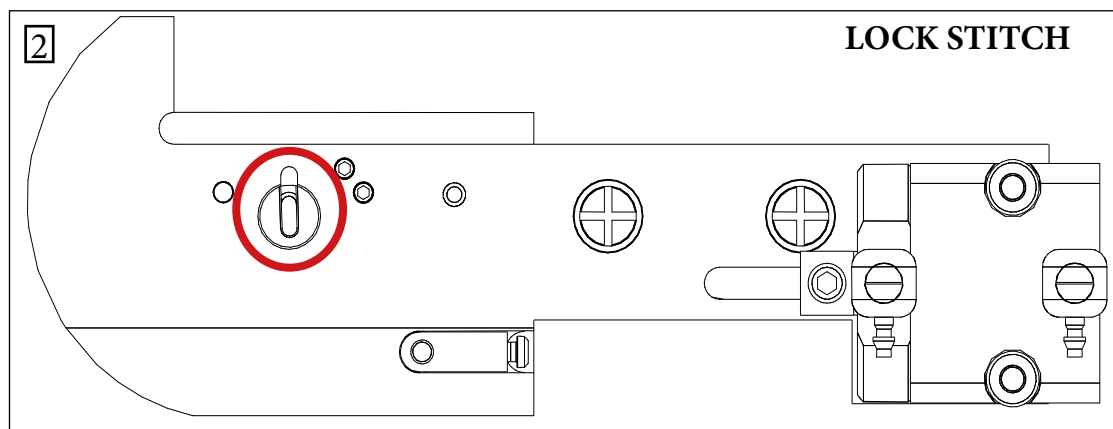
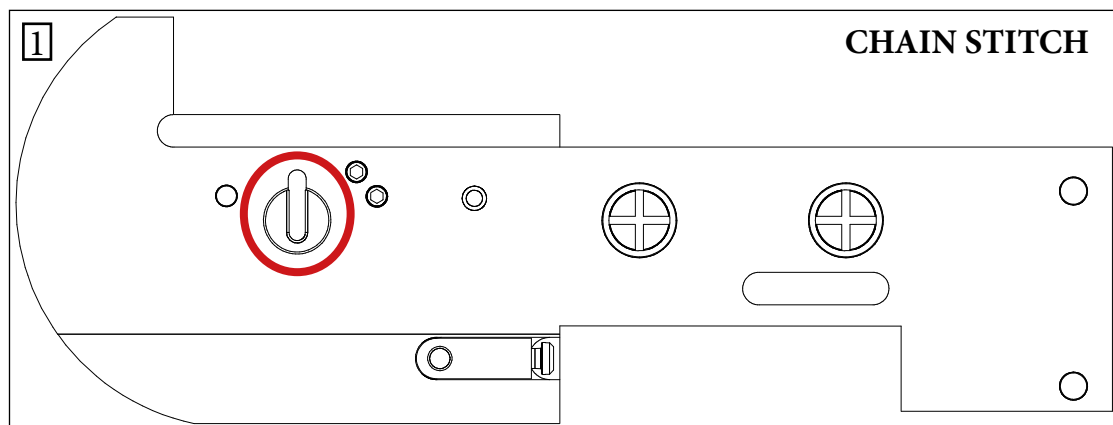

9.1- Moving knife adjustment

The moving knife have to be adjusted to move smoothly but without any play compare the fixed knife, to adjust the play between the Moving Knife and the Needle Plate loosen the safety screw "A" and adjust the pressure rotating the screw "B" until the Moving knife has not the possibility to move upward and downward, you must feel it free during forward and backward stroke when you move it. After the pressure have been adjusted tighten the safety screw "A".

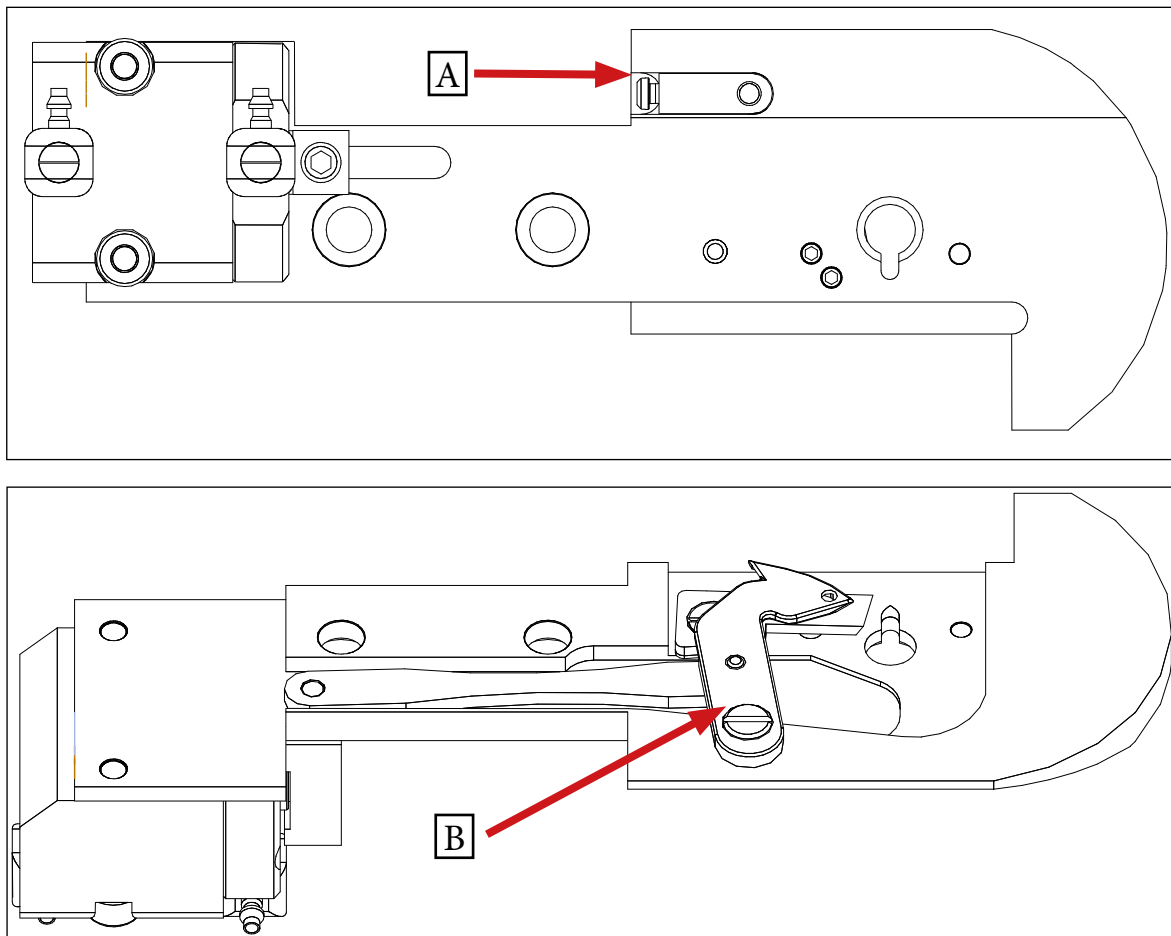

9.2- Fix knife adjustment

The Fix Knife position have to be adjusted that the moving knife will follow the trajectory as in the bellow drawing:

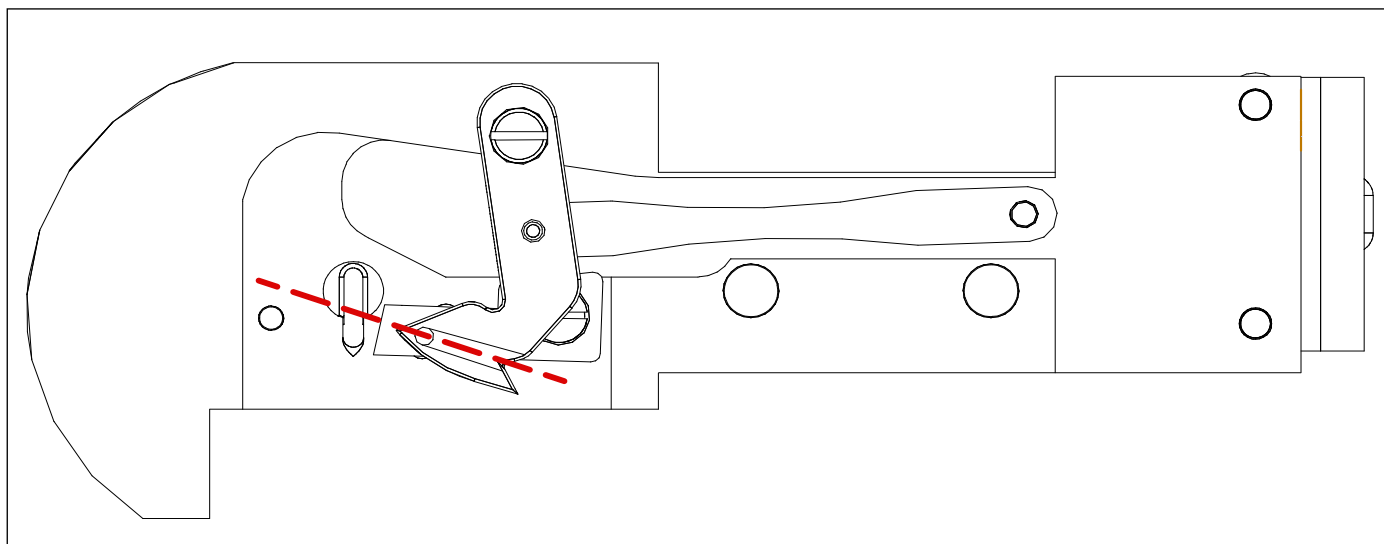

To adjust the pressure between the Moving Knife and the Fix knife rotate the two grub screw, with a 1,5mm allen key, until there is enough pressure for the moving knife to cut the threads.

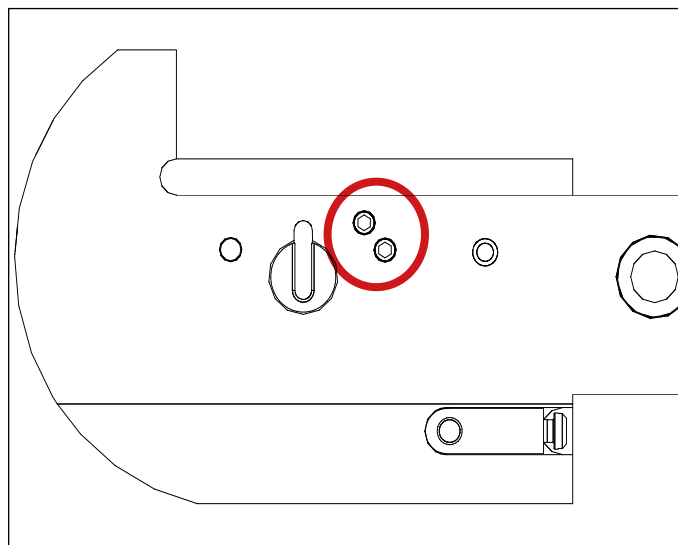
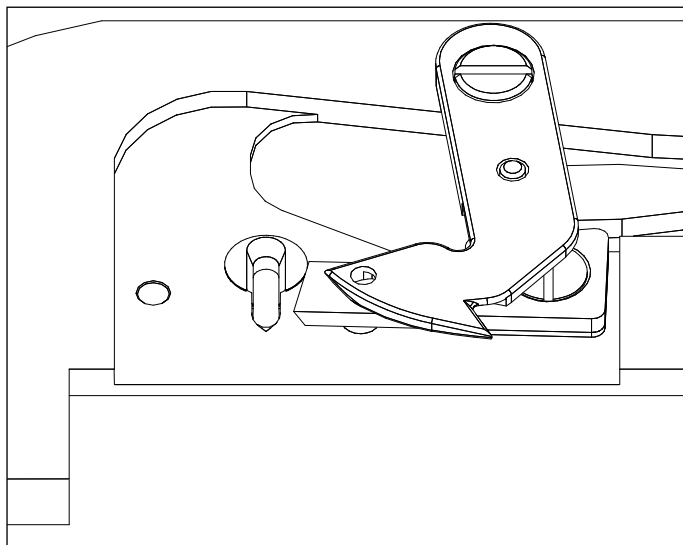

The needle plate for the lockstitch is equipped with a thread guide spring, the position has to be as close as possible to the fix knife without touching it and at the same height.

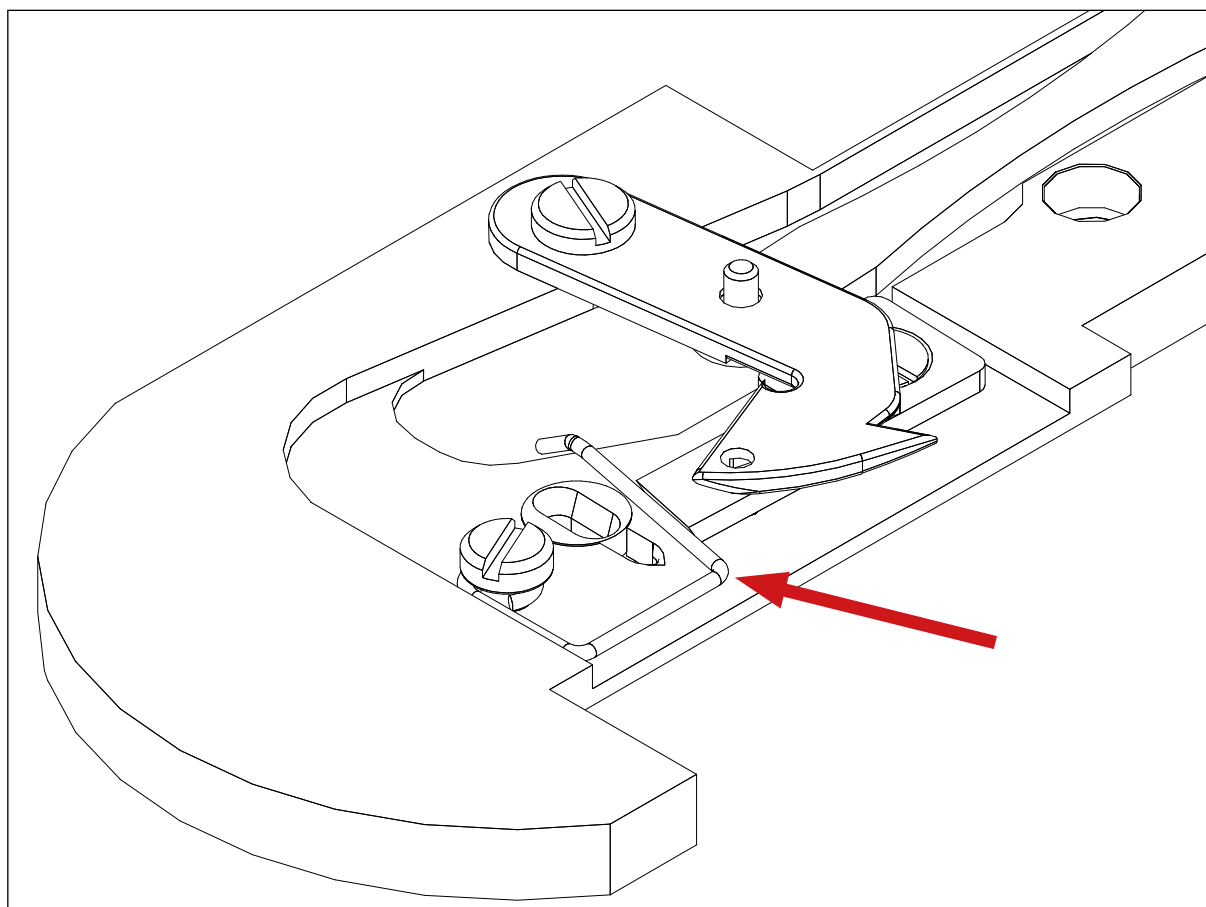

To guaranty a perfect trim of the thread the needle plate have to positioned that the needle is passing perfectly in the center, the position of the needle plate can be adjusted by loosen the 2 screws as image 1 and move the needle plate so that the needle enters with equal distance on right and left side of the needle plate

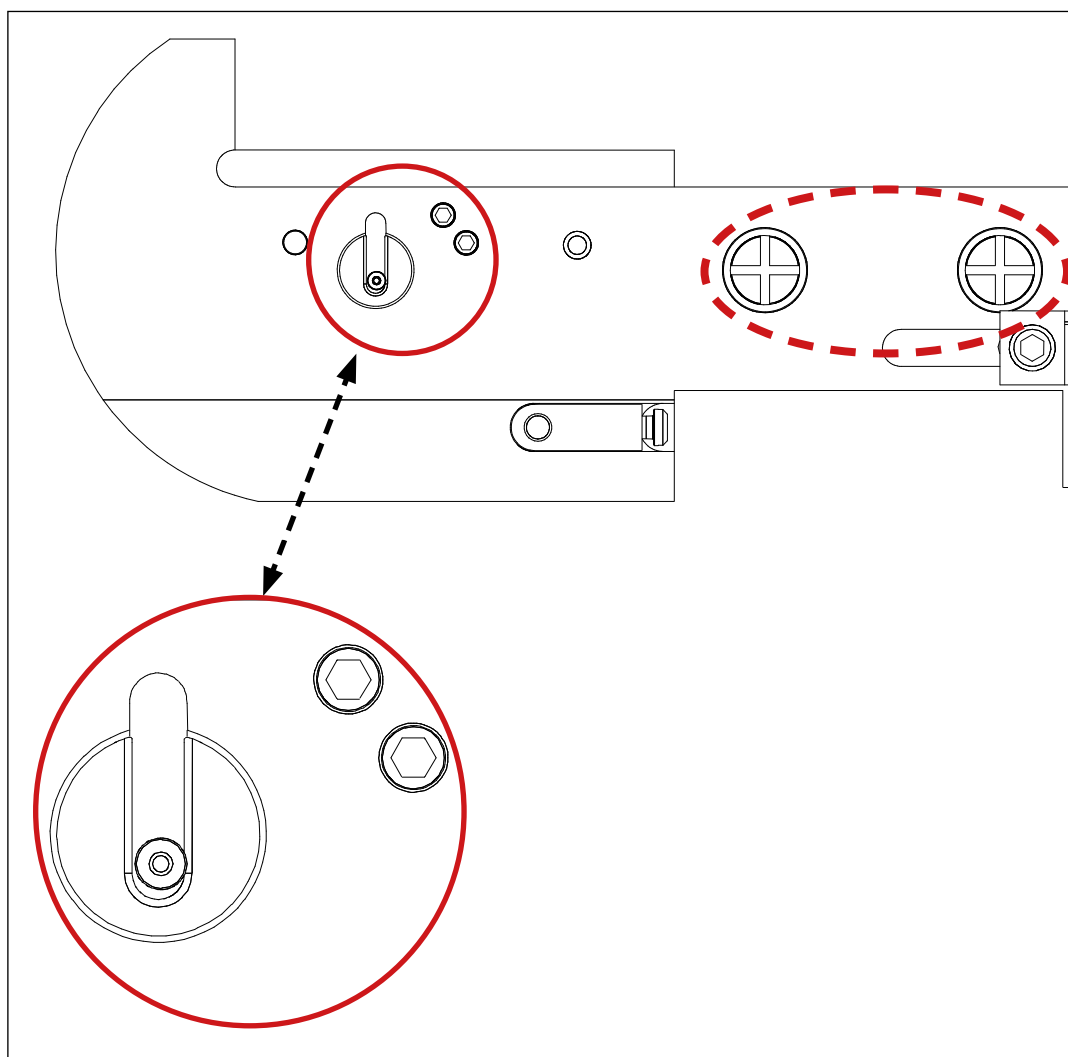

10. NEEDLE BAR TRANSLATION MOVEMENT

The function of this eccentric is to move the needle bar in synchrony with the puller rotation and the material movement.

To adjust correctly this eccentric follow the bellow steps:

Tighten the first grab screw of the eccentric (image 1) and leave the other one loose, press the stitch length button (image 2) and rotate the hand wheel opposite respect the rotation sense until end stroke.

Loosen the tightened grab screw and press the stitch length button (image 2) and always rotating the hand wheel opposite respect the sense of rotation turn it until the 0 of the hand wheel is in correspondence with the screw (image 3). Tighten both grab screws on the eccentric and pushing the stitch length button (image 2) rotate the hand wheel until the number 5 is in correspondence with the screw (image 4).

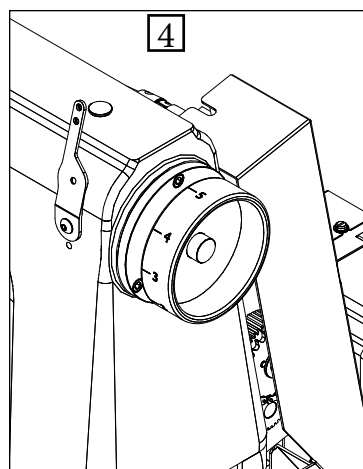
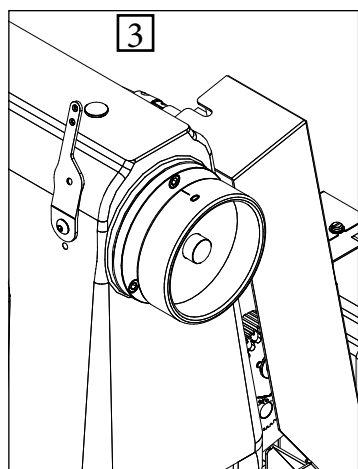
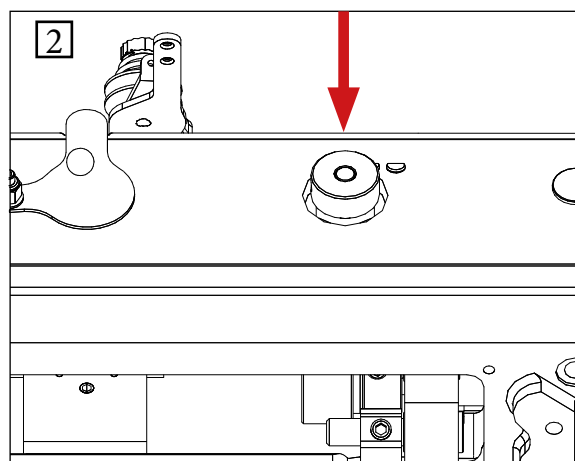
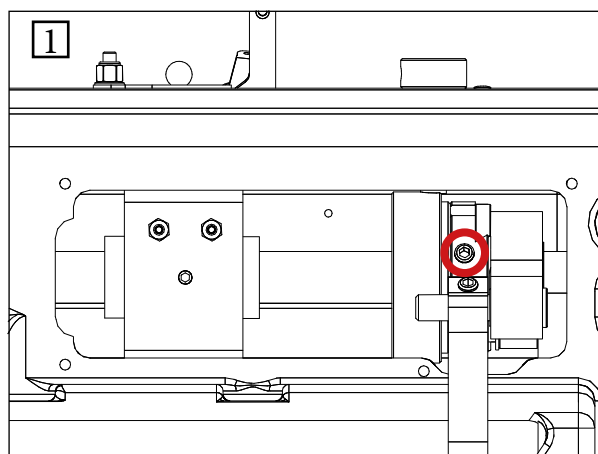

At this point press the stitch length button (image 2) and take the hand wheel so that the 0 is in correspondence with the screw (image 3) and then adjust the needle feeding as desired.

10.1- Needle position

To adjust the needle position:

Turning the hand wheel in rotation sense when the needle is going down at the entrance point of the needle plate and see if the distance between the 2 is at least 1,5mm

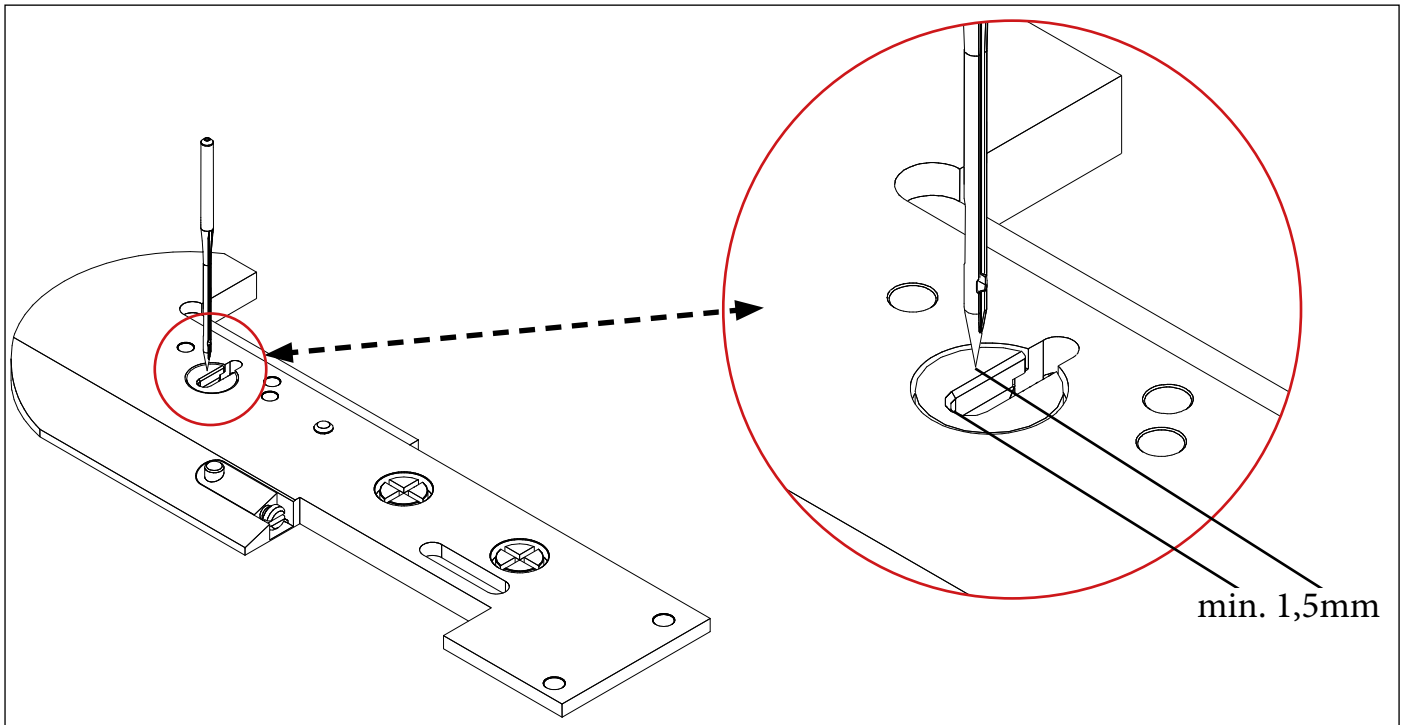

To adjust the position loosen the screw (as image below and position the needle at 1,5mm from the edge of the needle plate as above image)

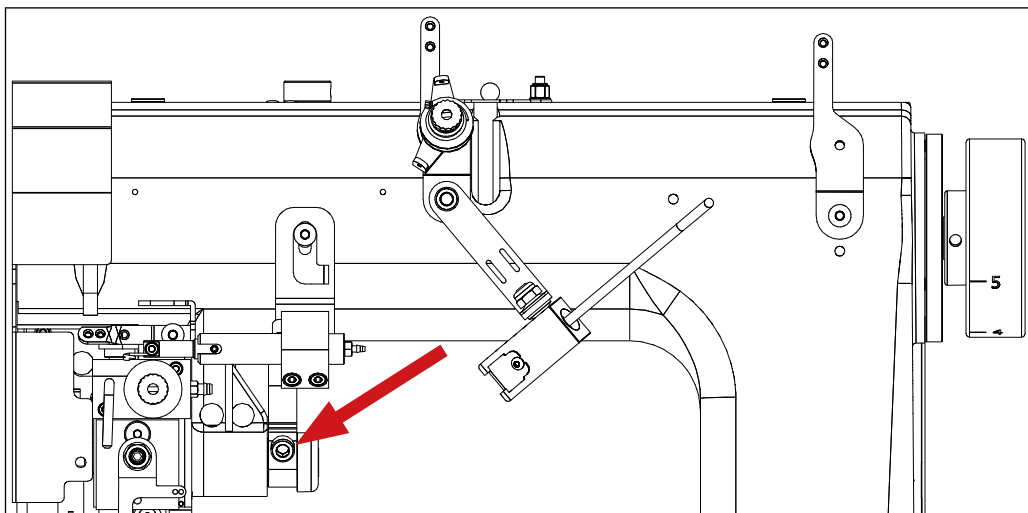

Attention!! Check the looper timing after the needle bar position has been modified.

11. CHANGING FROM CHAINSTITCH TO LOCKSTITCH

To change the unit from chainstitch to lockstitch option have to follow this steps:

1. Remove the complete looper shaft with his support and the spreader shaft (picture 1):

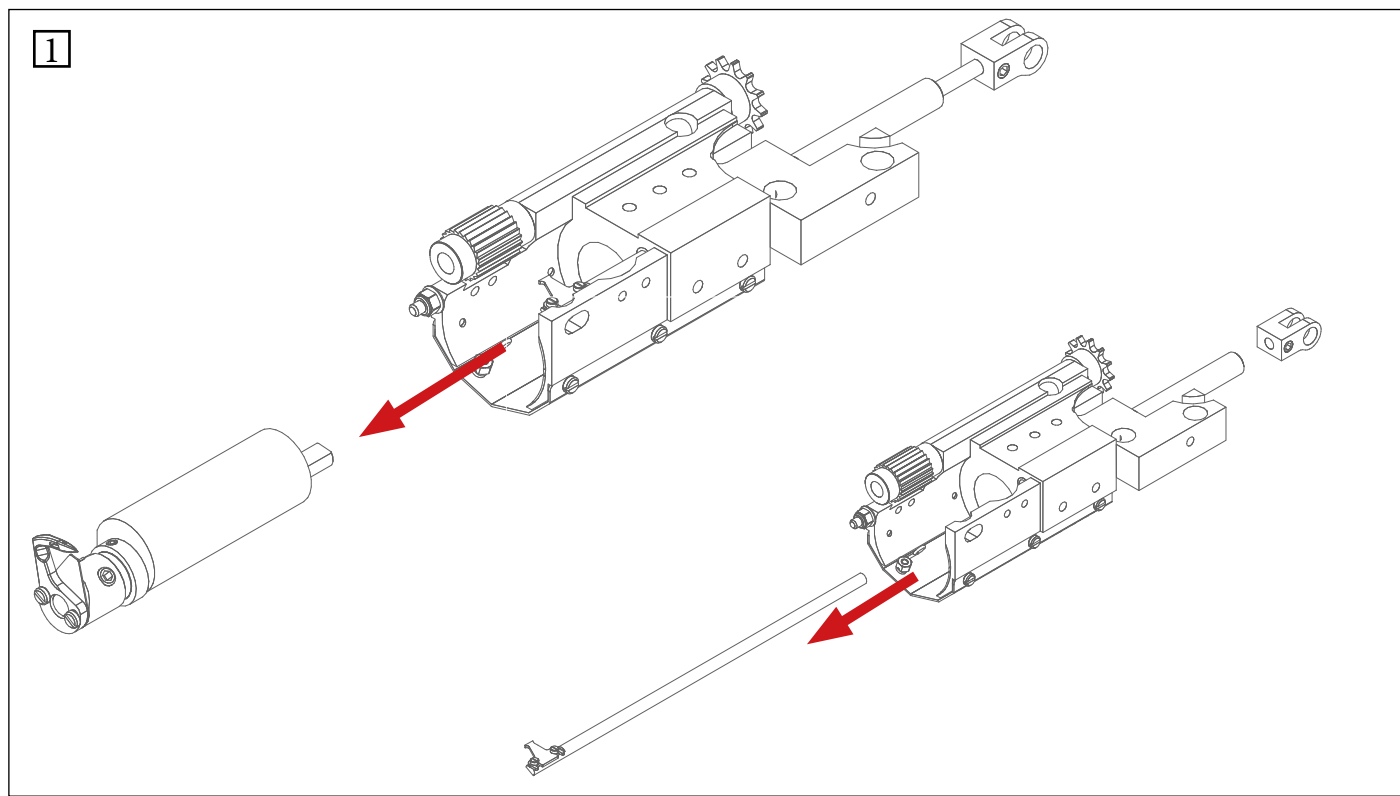

2. Change the position of the looper cam (A) and looper movement rod (B) in picture 2 rotating by 180° shown in picture 3:

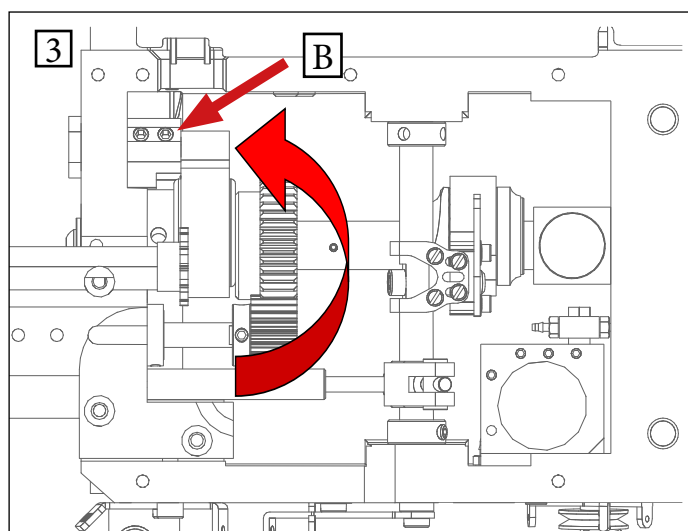
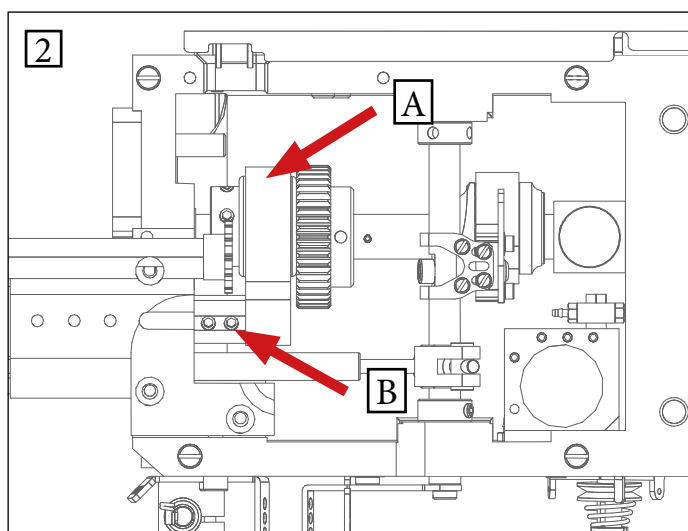

3. After the looper movement rod is in the new position fix it with the pin A, shown in picture 4 and tighten the two grub screws:

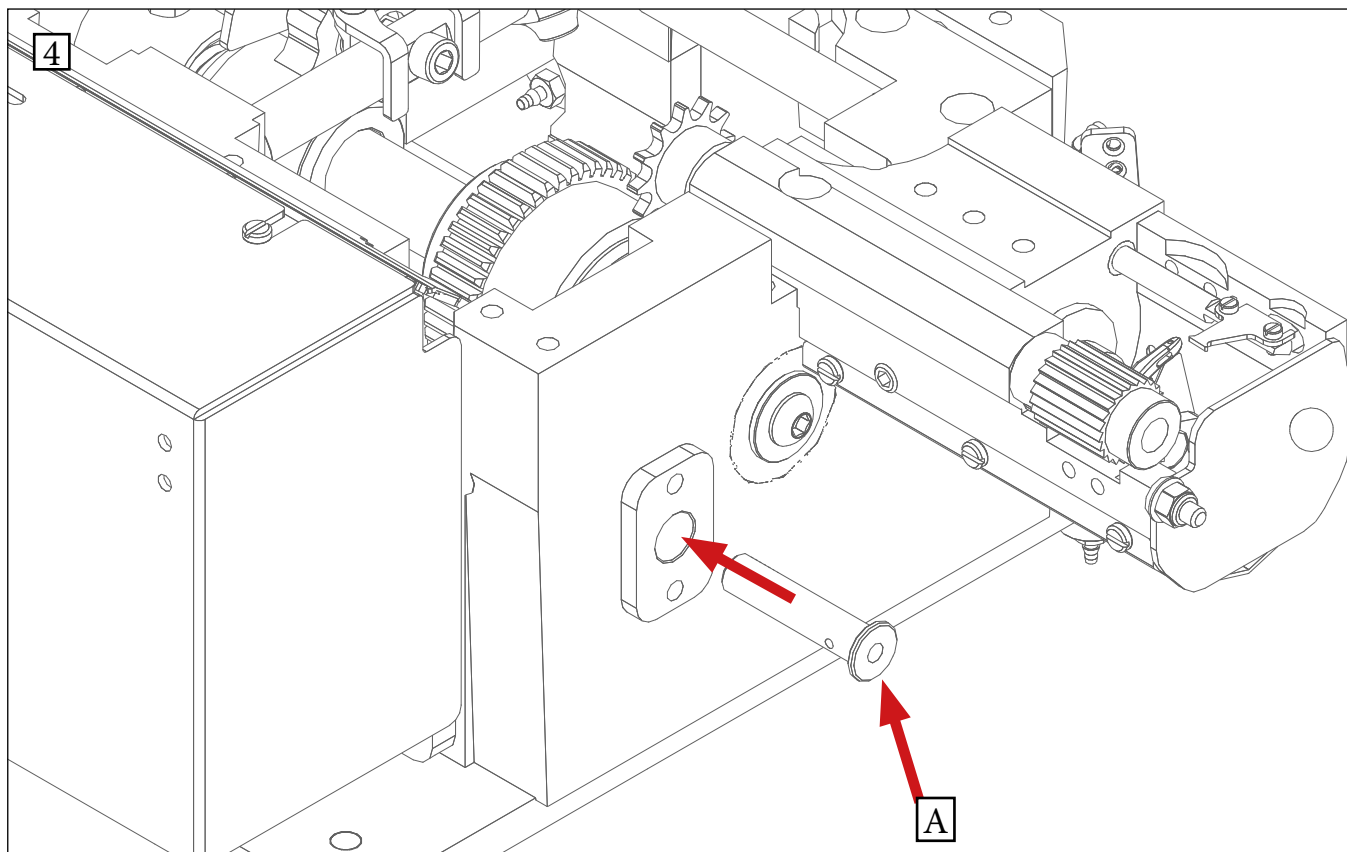

4. After the looper movement rod is it fixed with the pin insert the rotary hook shaft and his support and attach the small gear (B) on the roatry hook shaft attached at the main gear (A) from the main shaft, picture

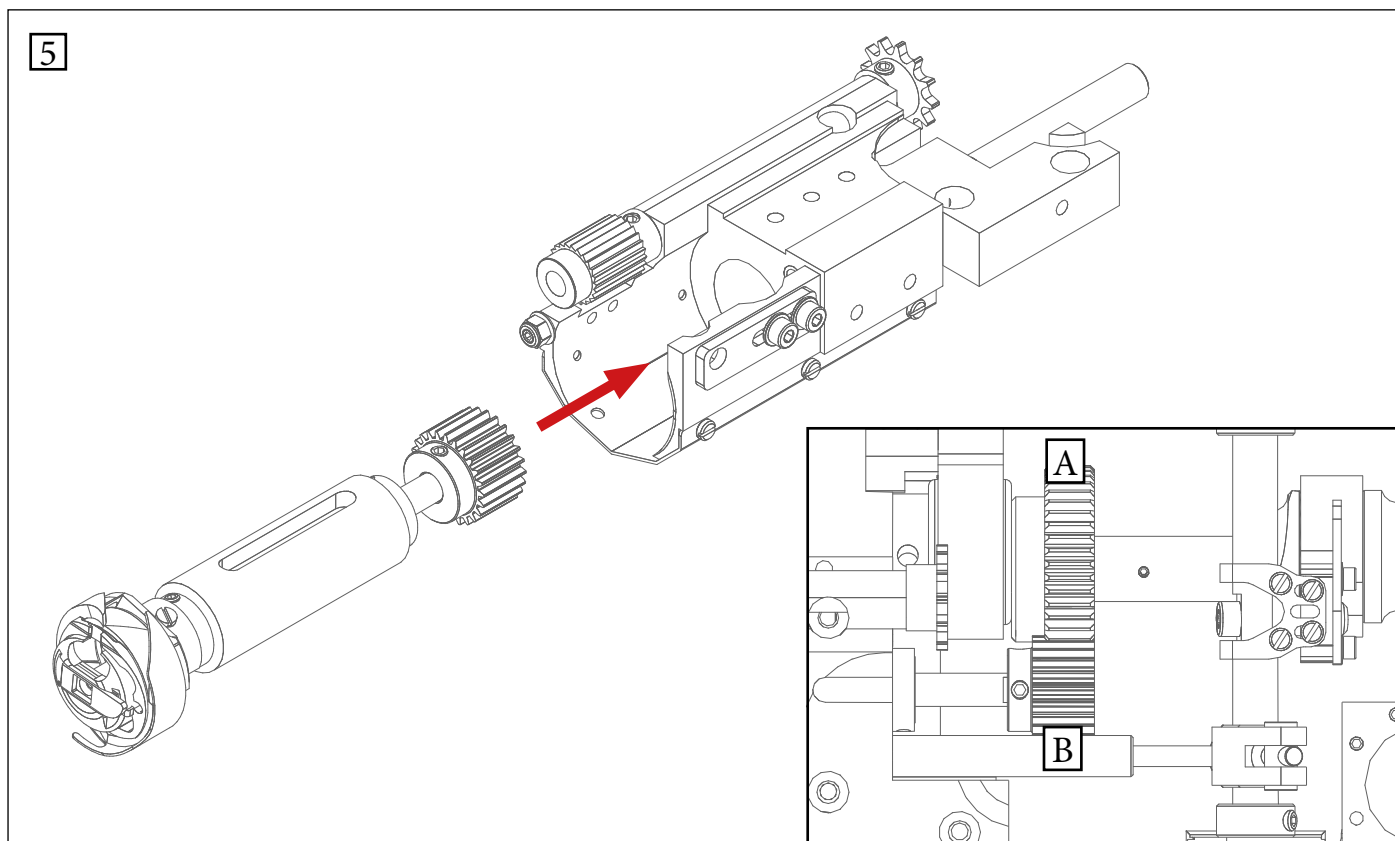

5. After the rotary hook shaft is fixed on the correct position , fix the basket retainer (A) and make the timing as have been explained on Chapter 8.2

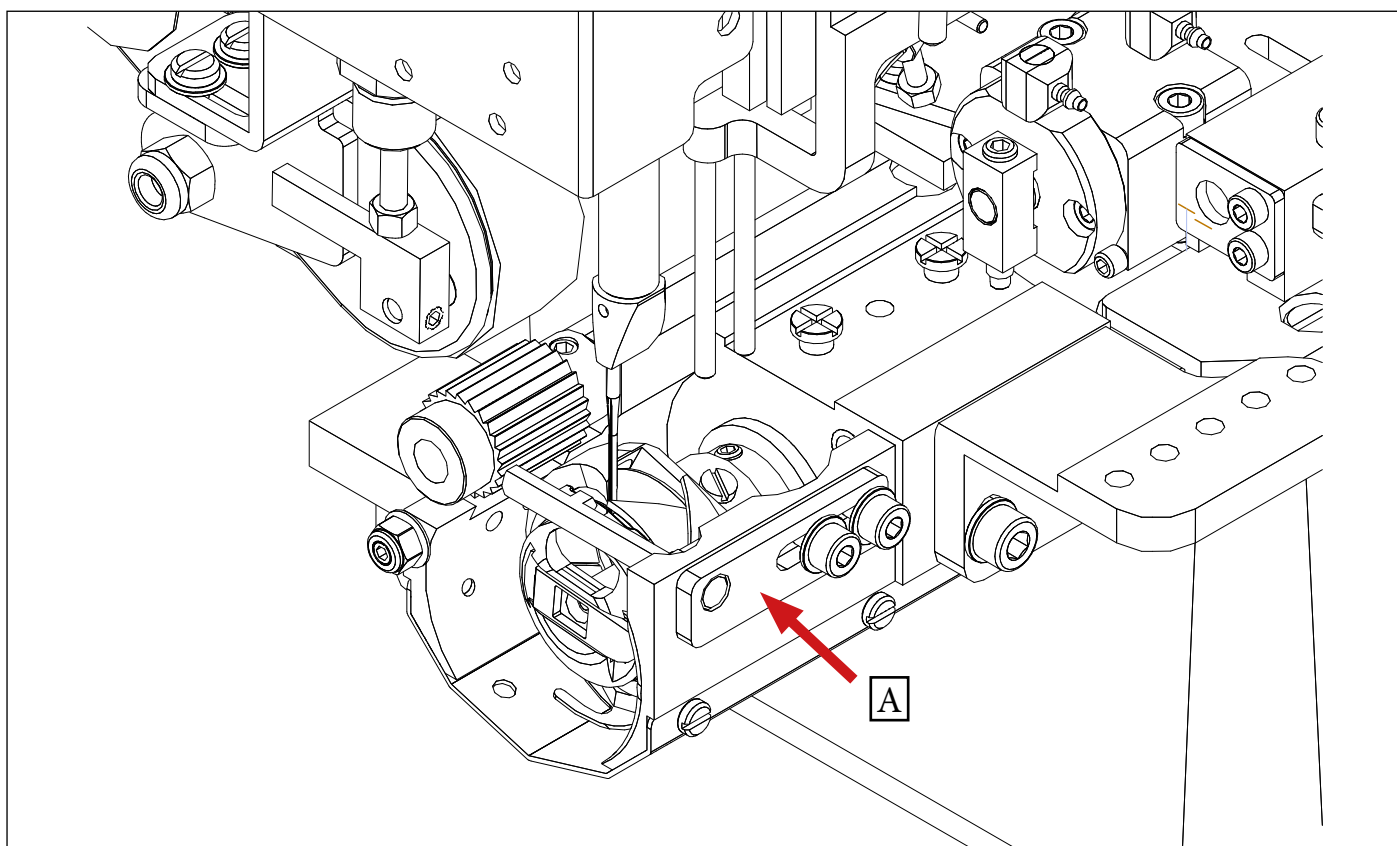

6. For the revers operation, from lockstitch to chainstitch make the same operations in the revers way.

FOR MORE DETAILS OF THIS OPERATION YOU CAN WATCH A TUTORIAL VIDEO IF YOU CLICK ON THE FOLLOWING LINK :

--- LINK-LINK-LINK-LINK-LINK-LINK-LINK-LINK-LINK-LINK ---

12. STITCH LENGTH ADJUSTMENT

To adjust correctly the stitch length we must first regulate the puller/gear transport and then the needle tip feeding as explained in the next paragraph.

12.1- Adjusting the puller transport

The following appears on the control panel display:

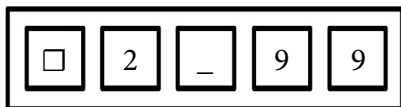

Keep pressed the down arrow  key and C button at the same time.

Display will show:

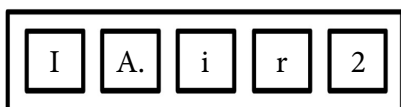

Press up arrow key until the following appears on the display:

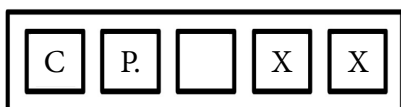

Setting number of impulses in a rotation

With C and D key the value will change increase the value to increase the stitch length or decrease the value to decrease the stitch length.

Press the up and down arrows at the same time in order to exit this mode.

IMPORTANT: Every time change the number of impulses, turn power OFF, wait for the console display to switch off and then switch the unit back on again.

Once selected the desired stitch length on the control box by (CP) value we must adjust the movement of the needle as explained in the next paragraph.

12.2- Needle tip feeding adjustment

Press button A on the Upper part of the Head and turn the hand wheel till.

Button A falls into the slot, then by turning the hand wheel towards the operator (Anticlockwise direction) the movement of the Needle Bar gets longer. By turning the hand wheel towards the operator (Clockwise direction) the movement of the Needle Bar gets shorter. Release the button A once selected the correct stitch length. To check the correct position insert a piece of paper under puller and presser foot and turn the hand wheel to verify if the needle perfectly punches the paper, or, the paper has been ripped (elliptic hole). Adjust the movement of the length until the hole is perfectly performed.

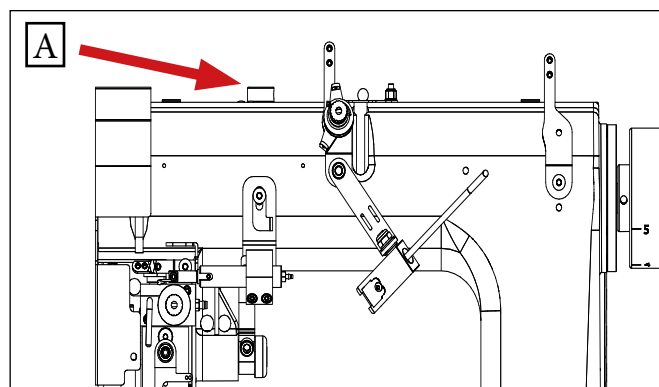

ATTENTION



Never press button A while the machine is turning.
Before starting the machine make sure that button A is disconnected.

13. FINAL CONDENSATE STITCHES

The unit 3022 BHE equipped with the chainstitch version before trimming, automatically does the condensed stitches. To select the number of condensed stitches:

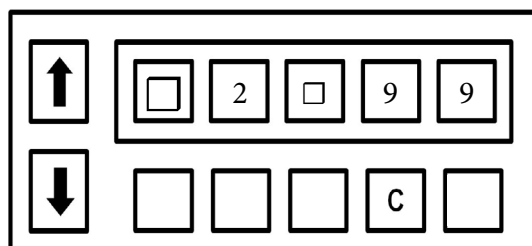

From the main screen press 1 time the up arrow key, and this screen appears

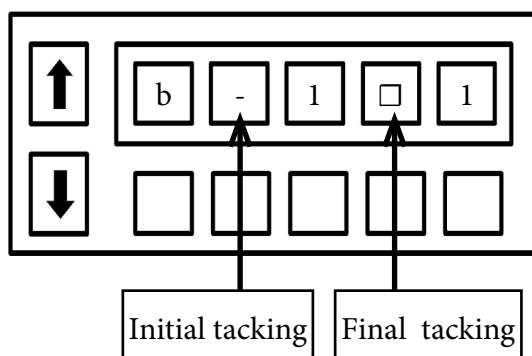

To activate the initial or final tacking mode press the key under the symbol (A initial C final) remembering that

- = OFF and = ON

Press up arrow key 1 time and display shows:

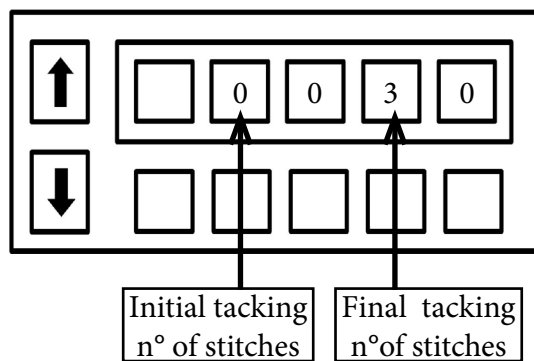

To change the quantity of stitches performed on the initial or final tacking change the value by pressing the key under the value to be changed. Press down arrow key 2 times to exit.

After selecting the n° of stitches to be performed as tacking, using the selector on the electrical box cover. It is possible to select the DENSITY of the stitches during tacking mode. The number selected will divide the stitch length during the tacking mode.

EXAMPLE:

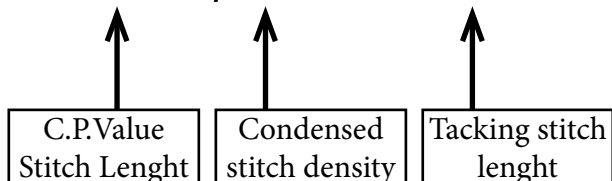

$$3.0\text{mm} / 3 = 1.0\text{mm}$$





VI.BE.MAC. RECOMANDS:
to use the condensed stitch length not less then 1mm

13.1- Thread trimming output start angle

Regulating the trimming output angle on the BHE unit:

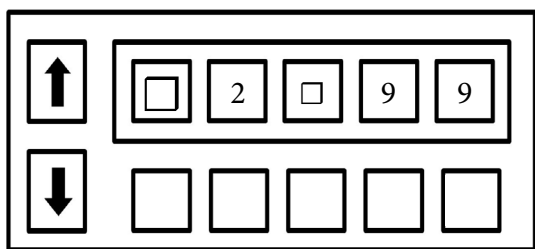
From the main screen keep pressed  +  arrow keys



Press the up arrow key  until we reach the parameter R8

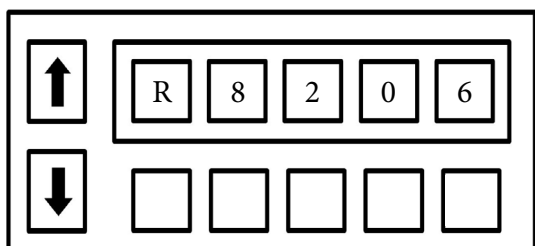

R8 parameter determines the stop position after the inverse rotation of the unit and should position 1mm before the upper dead point of the needle bar

To adjust correctly the value of R8 execute a few stitches and then position the needle bar at 1mm before the needle bar upper dead rotating by hand.

Move the knife by hand using a screw driver to move the cylinder, and check the position of it with the thread triangle.

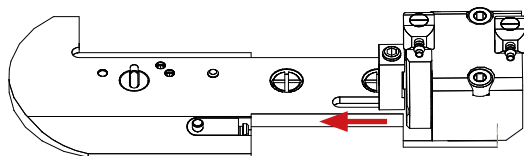

In this way you will control if the knife enters perfectly between the threads and when it returns it cuts both. Determined the correct position apply a mark on the sewing head and one corresponding on the hand wheel.

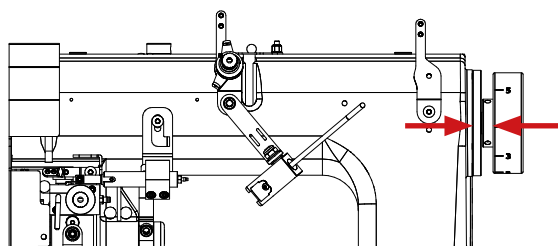

After applying the reference mark execute a cut by back pedalling and see if the 2 marks align.

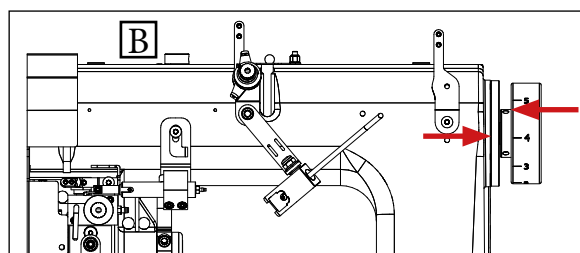
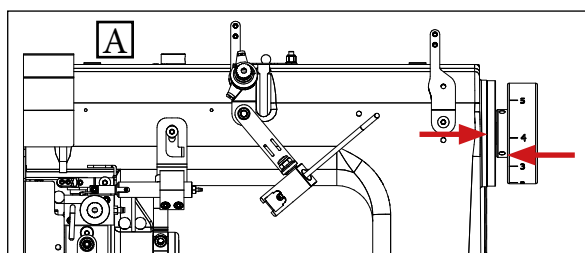

If after the cutting the marks are as fig. A we must increase the value of R8 instead if the marks are as fig. B we must decrease.

These images are for reference regarding the stop position for trimming (R8)

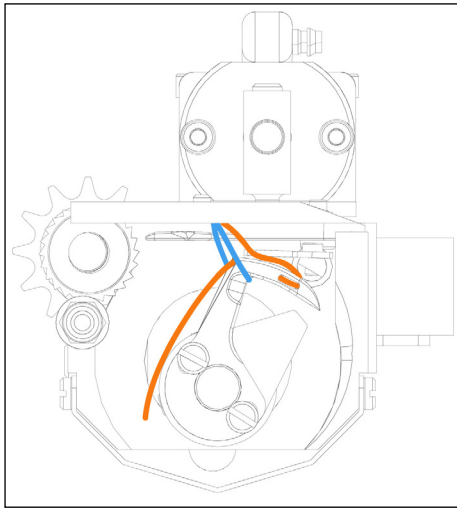

THE MACHINE STOPS AS FOR THE R8 VALUE SET

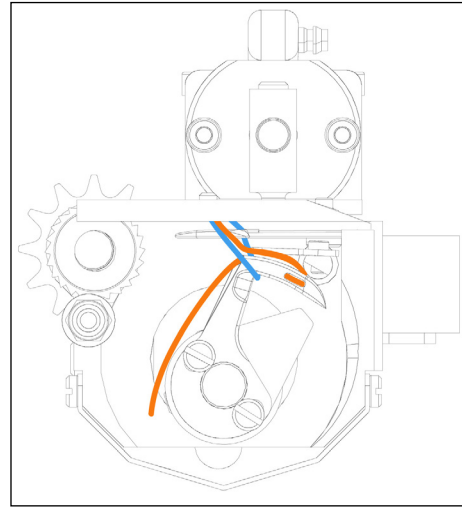

AFTER THAT THE OUTPUT OF TRIM WILL BE ACTIVATED

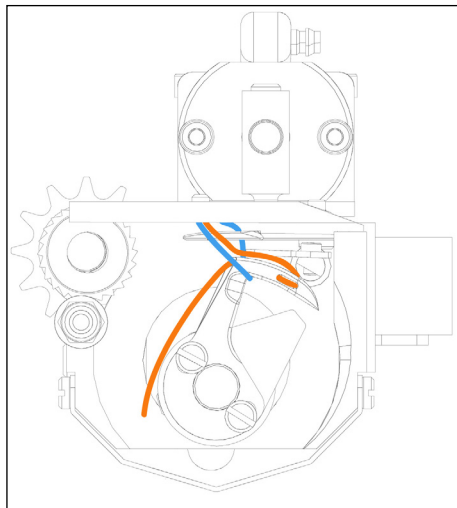

MOVABLE KNIFE IS MOVING FORWARD ENTERING IN THE TRIANGLE OF THREAD

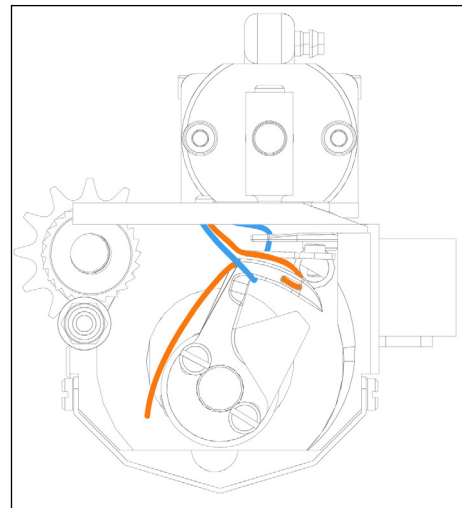

MOVABLE KNIFE IS COMPLETELY FORWARD

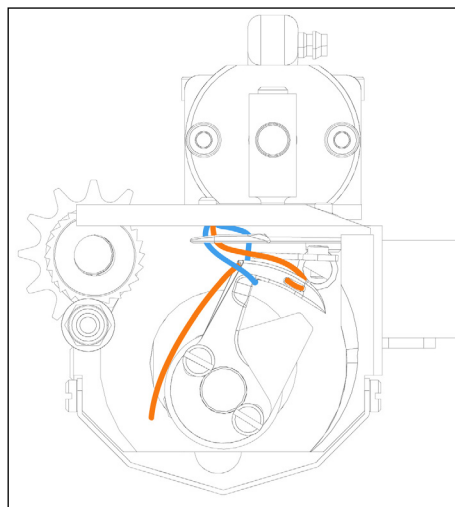

MOVABLE KNIFE IS GOING BACKWARD AND WILL CUT PERFECTLY THE UPPER AND LOWER THREAD

14. MITSUBISHI SERVOMOTOR

On the automatic unit is installed: a type XL-CE MITSUBISHI Servomotor linked to a GMFY model panel. The software parameters are modified in respect to normal series, through a specific programmed of Inputs/Outputs. A pulley with diameter of 85mm is mounted on the motor and the machine turns at about 4000 stitches per minute.

14.1- Panel type GMFY

To select the various functions in the Motor Panel mod.GMFY there is a Display and a sequence of buttons to call required functions in the menu. Set the type of sewing machine referring to the list of the original technical manual.

14.2- Slow start speed setting

On the display appears:

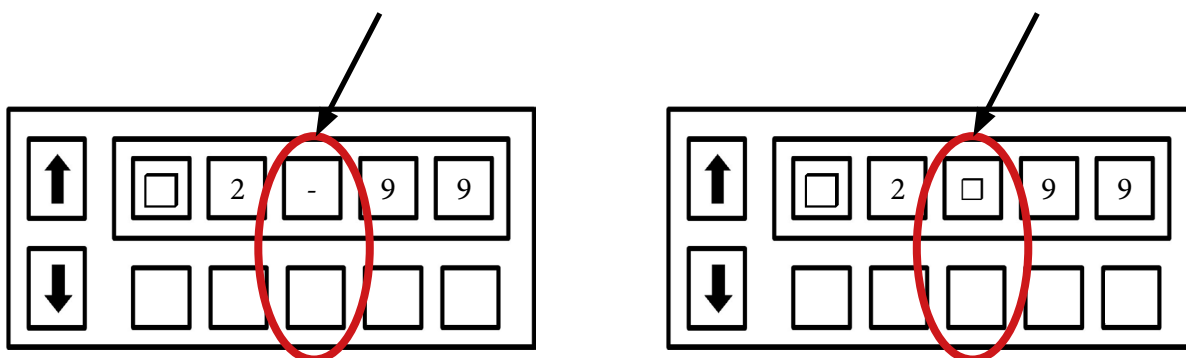

The second symbol identify if the <SLOW START function is enable or disable

SLOW STARTS enable (ON) the symbol that appears is the follow : (square)

SLOW STARTS disable (OFF) the symbol that appears is the follow: - (line)

You change the value by B key.

On the display appears:

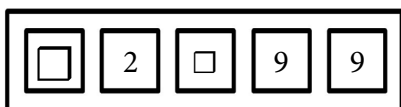

in case that the function is ON

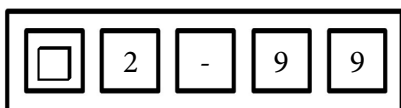

in case that the function is OFF

14.3- Speed setting – slow start speed

The following appears on the display:

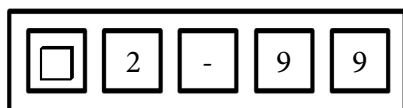

Press the up arrow and the down arrow at the same time.

The following appears on the display:

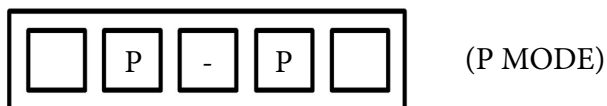

Hold down the two keys until the display changes to:



Use the A, B, C and D keys to change the value. Set it to 3699 value

Press the down arrow, the following appears on the display:

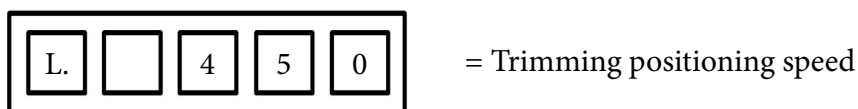

Use the A, B, C and D keys to change the value. Set it to 450 value

Press the down arrow until the following appears on the display:

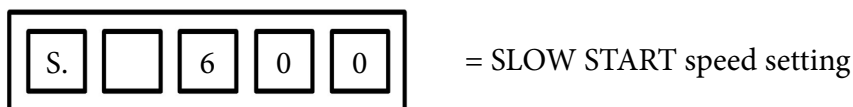

Use the A, B, C and D keys to change the value. Set it to 600 value

Press the down arrow until the following appears on the display:



Use the D key to change the value. Set it to 3 value

Press the down arrow and the down arrow at same time to exit.

14.4- Sewing machine speed percentage setting

On the display appears:

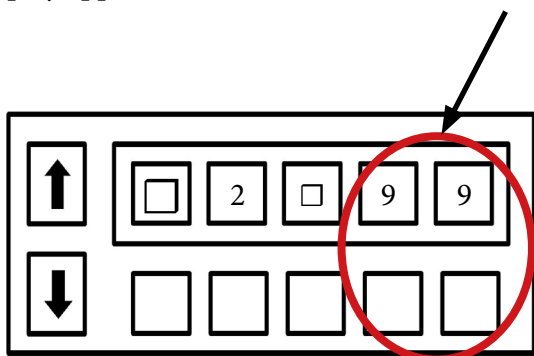

The couple of numbers identify the maximum speed percentage value that the machine runs at setting by H. parameter in P mode.

Press the C and D keys to change the speed percentage value.

14.5- Input / output test

The following appears on the display:

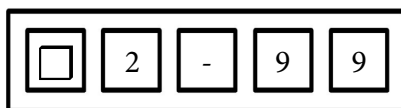

Press the up arrow, the down arrow and button A at the same time.

The following appears on the display:

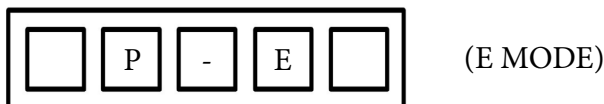

Hold down the two keys until the display changes to:

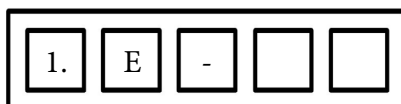

The last error message on the machine appears on the display.

Press the down arrow key.

The following appears on the display:

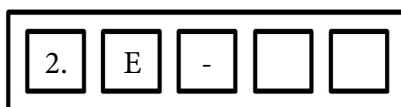

The penultimate error message on the machine appears on the display.

Press the down arrow key.

The following appears on the display:

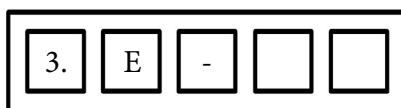

The third from last error message on the machine appears on the display.

Press the down arrow key.

The following appears on the display:

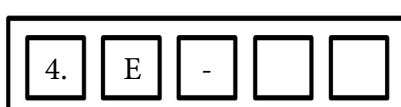

The fourth from last error message on the machine appears on the display.

Press the down arrow key.

The following appears on the display:

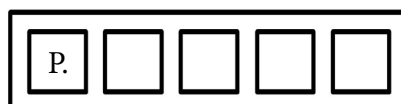

Actual motor running time in hours
multiply the value by 10 (Total hours = n° X 10)

Press the down arrow.

The following appears on the display:

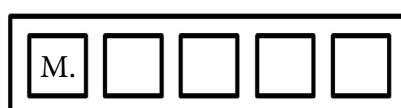

Actual motor rotation time in hours
multiply the value by 10 (Total hours = n° X 10)

Press the down arrow

All INPUT settings are shown (from iA to iP, from i1 to i5) it is possible to test settings manually.

The following appears on the display:

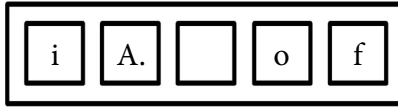

input setting iA = OFF

The INPUT value (ON/OFF) of parameter iA is shown.
 Varying the setting of each input the value changes from off to on.
 The inputs are:

INPUT	ACTUATOR
IA	Knee switch
I1	Front cover

Press the down arrow when appears on the display:

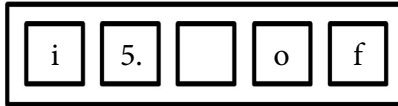

input parameter i5 = OFF

The INPUT value (ON/OFF) of the last parameter i5 is shown.
 Press the down arrow.

The following appears on the display:

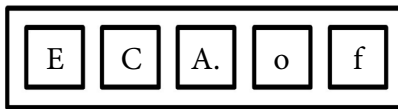

input parameter phase A Encoder Motor

The INPUT value (ON/OFF) of the parameter ECA is shown.
 Rotating the wheel on the machine changes the value continuously between ON and OFF.
 Press the down arrow.

The following appears on the display:

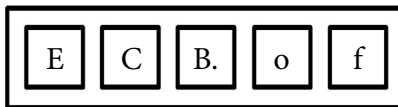

input parameter phase B Encoder Motor

The INPUT value (ON/OFF) of the parameter ECB is shown.
 Rotating the wheel on the machine changes the value continuously between ON and OFF.
 Press the down arrow.

The following appears on the display:

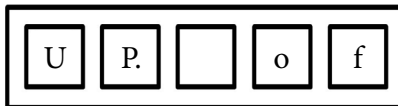

input parameter from the TAKE UP - UPPER DEAD POINT

The INPUT value (ON/OFF) of the parameter UP is shown.
 Rotating the wheel on the machine changes the value continuously between ON and OFF
 Press the down arrow

The following appears on the display:

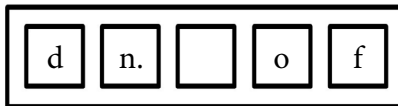

input parameters for the needle DOWN position sensor

The INPUT value (ON/OFF) of the dn parameter is shown.
 Rotating the flywheel on the machine changes the value continuously between ON and OFF

Press the down arrow

The following appears on the display:

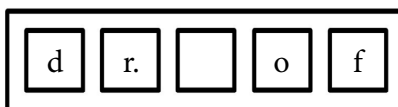

Shows the present angle of the needle DOWN sensor

The INPUT value (ON/OFF) of the “d r” parameter is shown. By rotating the synchronizer on the machine it is possible to change the value. Reference value 0° is the lower dead centre.

Press the down arrow.

The following appears on the display:

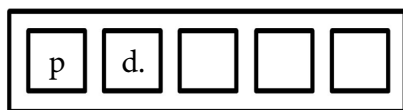

Numeric value which is equivalent to the tension given by the variable speed parameter VC with the foot pedal lowered. Setting range from 000 to 3FF.

Press the down arrow

The following appears on the display:

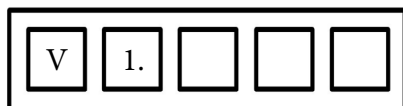

Numeric value which is equivalent to the tension given by the variable speed parameter VC with OPTION B connector. Setting range from 000 to 3FF.

Press the down arrow

The following appears on the display:

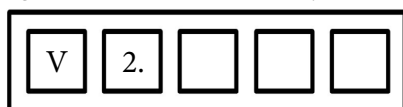

Numeric value which is equivalent to the tension given by the variable speed parameter VC with OPTION B connector. Setting range from 000 to 3FF.

Press the down arrow

The following appears on the display:

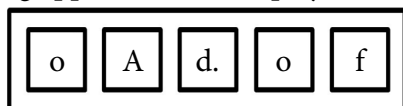

output signal 0A = OFF THREAD TRIMMER

The OUTPUT value for parameter 0A d is shown.

The parameters in **bold script** are the factory settings and are as follows:

FUNCTION	DISPLAY	PARAMETER
Virtual output 1 signal	(OT!)	01D.of
Needle cooling output signal	(NCL)	02D.of
TF output signal	(TF)	03D.of
Thread cutter signal	(T)	0AD.of
Thread discard signal	(W)	OBD.of
Needle cooling output signal	(NCL)	0CD.of
Tension release signal	(L)	0DD.of
Presser foot lifter signal	(FU)	0FD.of

Press the down arrow to scroll through the various parameters

All the OUTPUTS are shown and it is possible to test them manually (from 0A to 0F, and from 01 to 07)

The following appears on the display:

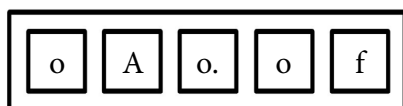

output signal 0 A = OFF THREAD TRIMMER

The OUTPUT signal of parameter 0A o is shown.

Press key D to change the value from OFF to ON.

The parameters in **bold script** are the factory settings and are as follows:

FUNCTION	PARAMETER
Folder	01o.of
Puller	02o.of
Thread cutter signal	0Ao.of
Needle cooling output signal	0Co.of
Tension release signal	0Do.of
Presser foot lifter signal	0Fo.of

Press the down arrow to scroll through the various parameters.

15. PARAMETER LIST

The main parameters list and the values from the setting installed on the XCGMF control box are listed bellow. To entry in the various programming modes below you must press the specify keys:

A mode	Press the down arrow + A
C mode	Press the down arrow + C
G mode	Press the down arrow + up arrow + C
H mode	Press the down arrow + up arrow + D
J mode	Press the down arrow + up arrow + A + B
P mode	Press the down arrow + up arrow
S mode	Press the down arrow + B+D

FUNCTION NUMBER	MODE	DIGITAL	FUNCTION NAME	3022BHE
	normal	12P.	1-2 Position	2
0000	P	H.	Maximum Speed	3500
0002	P	T.	Thread Trimming Speed	200
0003	P	N.	Start Tacking Speed	2500
0004	P	V.	End Tacking Speed	1800
0005	P	M.	Medium Speed	1800
0006	P	S.	Slow Start Speed	600
0007	P	SLN.	N° Of Slow Start Stitches	3
0024	P	FD.	Time To Motor Drive After Presser Foot Lifter Bring Down	150
0036	P	RU.	Reverse Run Needle Lifting After Thread Trimming	ON
0037	P	R8.	Ru Reverse Run Angle	232
0042	P	TR.	N° Of Stitches Setting For Auxiliary Feeding Rear Roller	KA1
0046	P	C8.	Needle Stop Position Before Fabric	60
0047	P	K8.	Reverse Run Angle From Down To Up Position	180
0048	P	E8.	On Angle Of Virtual Tm	90
0054	P	D8.	Needle Down Position Stop Angle	10
0055	P	U8.	Needle Up Position Stop Angle	180
0101	A	PDC.	Pedal Curve	40
0102	A	AC.	Acceleration Time Simple Setting	-
0103	A	ACT.	Acceleration Time	6
0104	A	DC.	Deceleration Time Simple Setting	L
0110	A	MR.	Setting Motor Pulley Diameter	85
0111	A	SR.	Setting Sewing Machine Pulley Diameter	60
0201	B	N.	Down Counter Setting Count Amount	1099
0206	B	USC.	Up Counter The Selection Of Counter Operation	OF
0300	C	IA.	Function Selection Of Input Signal Ia	IO5
0327	C	II.	Function Selection Of Input Signal Ii	NO
0357	C	I1.	Function Selection Of Input Signal I1	ES
0358	C	I1L.	Logical Conversion Function Of Input Signal I1	ON
0370	C	I2.	Function Selection Of Input Signal I2	IO1
0381	C	I5.	Function Selection Of Input Signal I5	SPM
0400	C	OC.	Function Selection Of Output Signal Oc	NCL
0416	C	O1.	Function Selection Of Output Signal O1	OT6
0421	C	O2.	Function Selection Of Output Signal O2	NCL
0484	C	A2.	Logic [And] Module A2 Input Functions Selection	IO6

FUNCTION NUMBER	MODE	DIGITAL	FUNCTION NAME	3022BHE
0487	C	N3.	Logic [And] Module N3 Output Functions Selection	FU
0489	C	N4.	Logic [And] Module N4 Output Functions Selection	HI
0491	C	A3.	Logic [And] Module A3 Input Functions Selection	IO7
0494	C	N5.	Logic [And] Module N5 Output Function Selection	OT6
0496	C	N6.	Logic [And] Module N6 Output Function Selection	T
0498	C	OR.	Logic [Or] Module Input Function Selection	IO6
0500	C	ORA.	Logic [Or] Module Alternative	ON
0501	C	R1.	Logic [Or] Module R1 Output Function Selection	OT5
0503	C	R2.	Logic [Or] Module R2 Output Function Selection	OT7
0520	C	CPK.	Feed Pulse Output (Cp) Cancel Function	OF
0521	C	CP.	Setting Cp Pulse Amount	32
0603	D	BM.	Tack Alignment	OF
0610	D	BTT.	Full Heeling Function Immediately After Start Tacking Stop	ON
0613	D	BTM.	Set Table Types Of Tacking	6
0900	G	TR.	Thread Trimming Mode	KA1
0901	G	TRM.	Motor Operation Mode During Thread Trimming	LK
0902	G	LTM.	Thread Trimming Output (T) Output Mode	T2
0903	G	LLM.	Thread Release Output (L) Output Mode	L1
0904	G	TS	Thread Trimming Output Start Angle	88
0905	G	TE.	Thread Trimming Output Angle	180
0906	G	LS.	Thread Release Output Start Angle	110
0907	G	LE.	Thread Release Output Angle	0
0908	G	T1.	Thread Release Output Start Time	20
0909	G	T2.	Thread Release Output Time	90
0910	G	L1.	Thread Release Output Start Time	100
0911	G	L2.	Thread Release Output Time	100
0912	G	R1.	Thread Release Output Start Time (Output Tf Start Time)	2
0913	G	R2.	Thread Release Output Time (Output Tf Time)	200
0918	G	F1.	Presser Foot Lifting Output Start Time	20
0919	G	FD.	Time To Motor Drive After Presser Foot Lifter Bring Down	150
1000	H	LHH.	Upper Limit Of Maximun Speed [H]	36
1002	H	LLH.	Upper Limit Of Low Speed [L]	3
1102	J	CWC.	Rotation Direction Changeover Prohibit	ON
1103	J	12C.	1-2 Position Changeover Prohibit	ON
1106	J	JKC.	Not Used	ON
1109	J	EBC.	End Tacking Validity Changeover Prohibit	OF
1111	J	SKC.	Start Tacking Type Changeover Prohibit	OF
1500	S	KSM.	Ks, Ks" Output Run Mode	ON
1501	S	SQS.	Simple Sequence Start Conditions	TR
1503	S	NS1.	Simple Sequence Output Ks1 Output Beginning Is Time Or The Number Of Stitch Is Selected	ON
1217	K	KTM.	End Tacking Mode When Tr Function Is Set To Chain Stitch	OF
1218	K	KDM.	Loock Stitch Tacking Menù Dsplay	OF

The main parameters that make the difference between the chainstitch version and the lockstitch version are listed below, the same list will be found on the body of the unit near the synchroniser.

FUNCTION NUMBER	MODE	DIGITAL	BHE LOCKSTITCH	BHE CHAINSTITCH
0037	P	R8.	10	232
0042	P	TR.	PRG	KA1
0054	P	D8.	28	10
0055	P	U8.	14	180

15.1- Reset

Press  +B + C appears:

RESET

Press D for 6-7 seconds

16. TROUBLESHOOTING GUIDE

1. Skip stitching:

- for chain stitch have to check the timing of the looper (check chapter 8.1);
- for lock stitch check the timing of the rotary hook (check chapter 8.2);

2. Skip stitching on the condensate stitches:

- this is a problem specific for the chain stitch configuration and it happens when the condensate stitches are too small, as has been explained in chapter 13 the condensate stitches don't have to be smaller than 1mm.

3. Needle get broken:

- check the position of the presser foot and the needle plate, the needle has to pass without touching;
- check the position of the needle guard, if the needle guard is not touching the needle the looper will break the needle;

4. Needle thread not getting cut:

- check the position of the fix knife and if it is sharp,
- check the position of the needle at the trimming time, if the moving knife is activated too early or too late the thread will not be cutted, the position of the needle can be adjusted by the position of the synchroniser or the value of the U8 parameter;

5. Looper thread not getting cut:

- check the timing of the spreader, check chapter 8.1.6;

6. Thread is too short after trimming:

- check if the thread tension is opening during the trimming, also by the output test, in E-Mode the parameter **0Do.of** can be switched on or off by pushing the D button ;
- if the tension is not opening by the output test check/replace the valve No: 2, also the connection of the valve, pin 7 and pin 8 of the SM connector from the XC-G control box;

7. Machine not running when the pedal is pressed:

- Also in the same time the square on the control box panel is not rotating, the reason is that the sensor from the needle bar cover is not activated or is damaged;
- Check if the pedal connector is inserted in the Control Box socket, first one from the left;

17. ERROR LIST

Error code	Probable cause	Inspection
P8r.oF	Is the power voltage too low? Is the power supply capacity too small? NOTE: It does this display when power supply is turned OFF, but this is not an error	Check the power voltage. Check the power supply capacity.
E1	Is the wire to the motor short-circuited? Is the sewing machine load torque too high?	Check the motor wiring. Check the sewing machine
E2	Is the power voltage too high? Is the sewing machine inertia too high?	Check the power voltage. Lengthen the deceleration time. (Refer to DC in [A] mode)
E3	Is the connector to the motor encoder securely inserted? Are the signal from the motor encoder correct? Is the sewing machine locked? Is the motor locked?	Check the connector insertion. Check the encoder signal. (Refer to [E] mode) Check the sewing machine. Check the motor.
E4	Is the motor connector securely inserted? Are the signal from the motor connector correct?	Check the motor connector insertion. Check the motor connector.
E6	Is an extraordinary signal inputted? (the signal as it repeats ON/OFF at the high frequency) Does the noise from outside enter an input signal	Check the input signal. Remove a noise source.
E8	Is the position detector connector securely inserted? Are the signal from the detector correct? (UP/DOWN signal interruption)	Check the detector insertion. Check the detector UP/DOWN signal. (refer to [E] mode)
E9	Is the solenoid wiring short-circuited? Solenoid defect (coil defect)	Check the solenoid wiring. Replace the solenoid.
M5	A error of the copy mode using the control panel. Is the control panel connector securely inserted? The voltage or the type of control panel is difference.	Check the connector insertion. Check the voltage and the type are right.
MA	The position data of the internal lever unit is defective. When power supply is turned ON. The pedal is not neutral position.	The pedal is neutralized. (it returns automatically 1 second later)

18. ELECTRIC DIAGRAM

Electrical Diagram 3022 BHE



Vi.Be.Mac.

Title	3022 BHE	Document	
Author	Faizi Giordano	Revision	
Vi.Be.Mac		Date	31/08/2017
File	ico\Electric Diagram_3022_BHE_V1.0_ENG.dsn	Revision	1.0
Revision	1.0	Date	31/08/2017
Document		Sheets	1

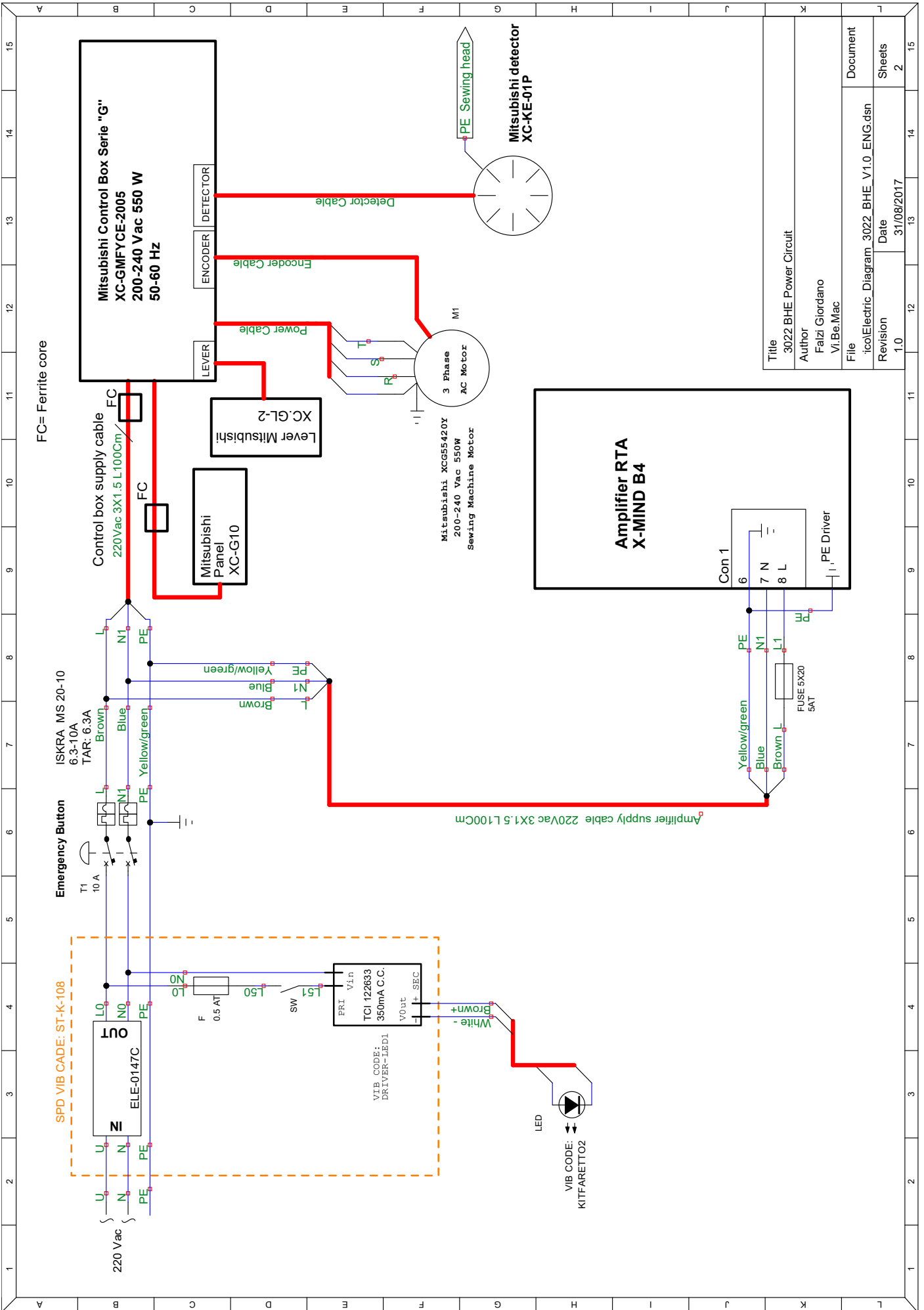

Title	3022 BHE Power Circuit
Author	Falzi Giordano
File	Vi.Be.Mac
Revision	1.0
Date	31/08/2017
Document	ico\Electric_Diagram_3022_BHE_V1.0_ENG.dsn
Sheets	2

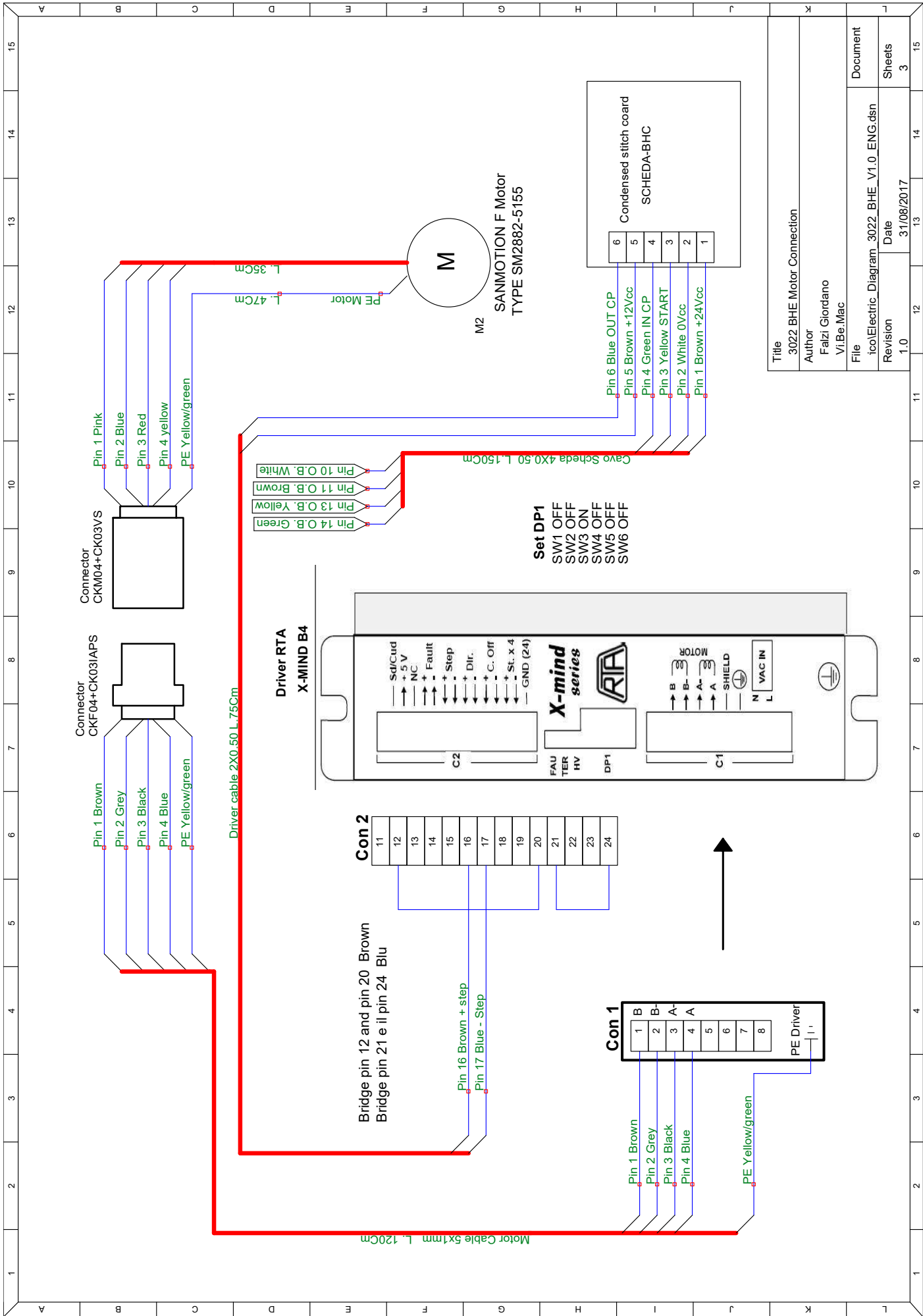

Title	3022 BHE Motor Connection
Author	Falzi Giordano
File	Vi.Be.Mac
Revision	1.0
Date	31/08/2017
Document	ico\Electric Diagram_3022_BHE_V1.0_ENG.dsn
Sheets	3

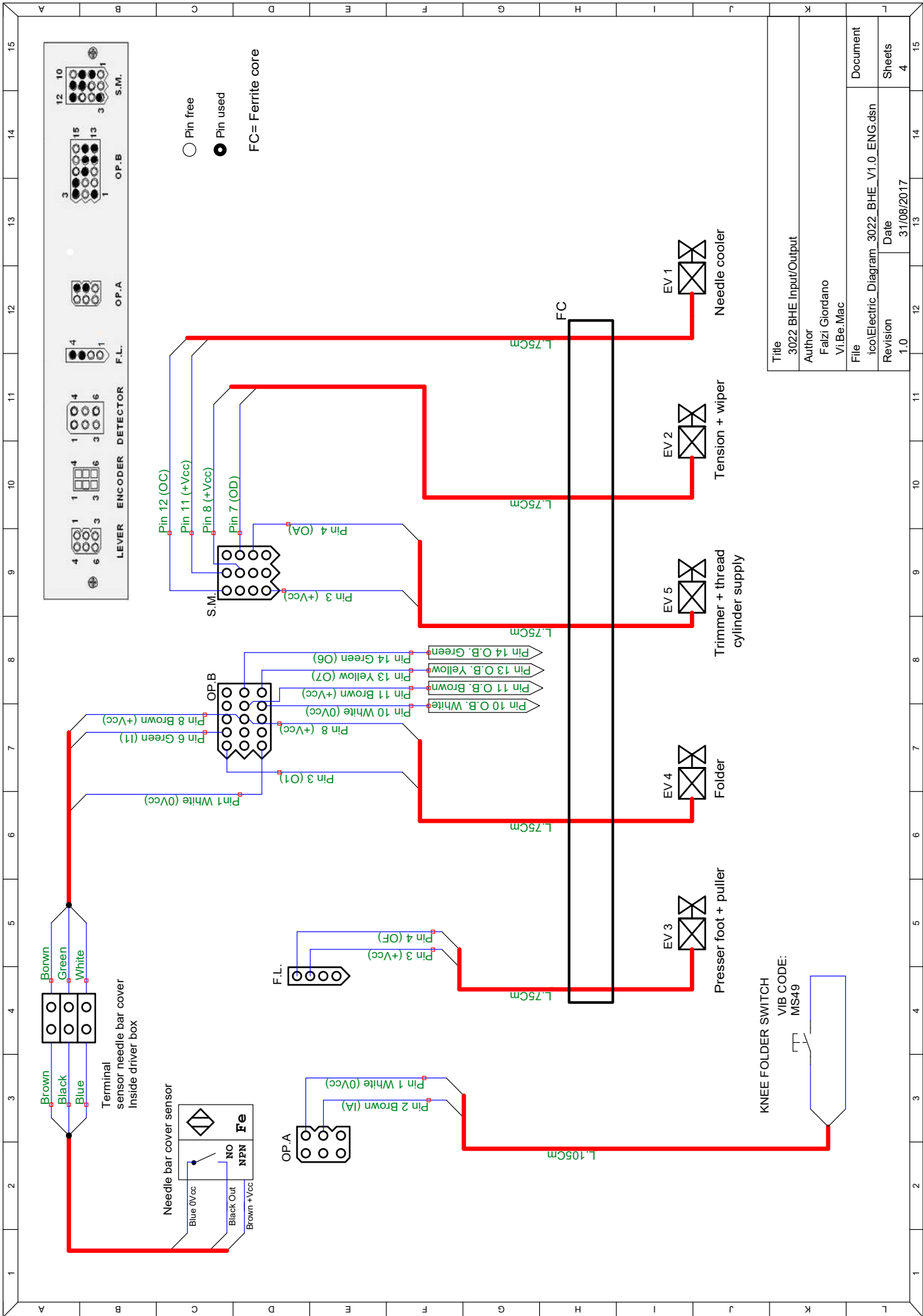

Title	3022 BHE Input/Output
Author	Falzi Giordano
	Vi.Be.Mac
File	ico\Electric Diagram_3022_BHE_V1.0_ENG.dsn
Revision	1.0
Date	31/08/2017
Document	4
Sheets	4

INTERNAL VIEW

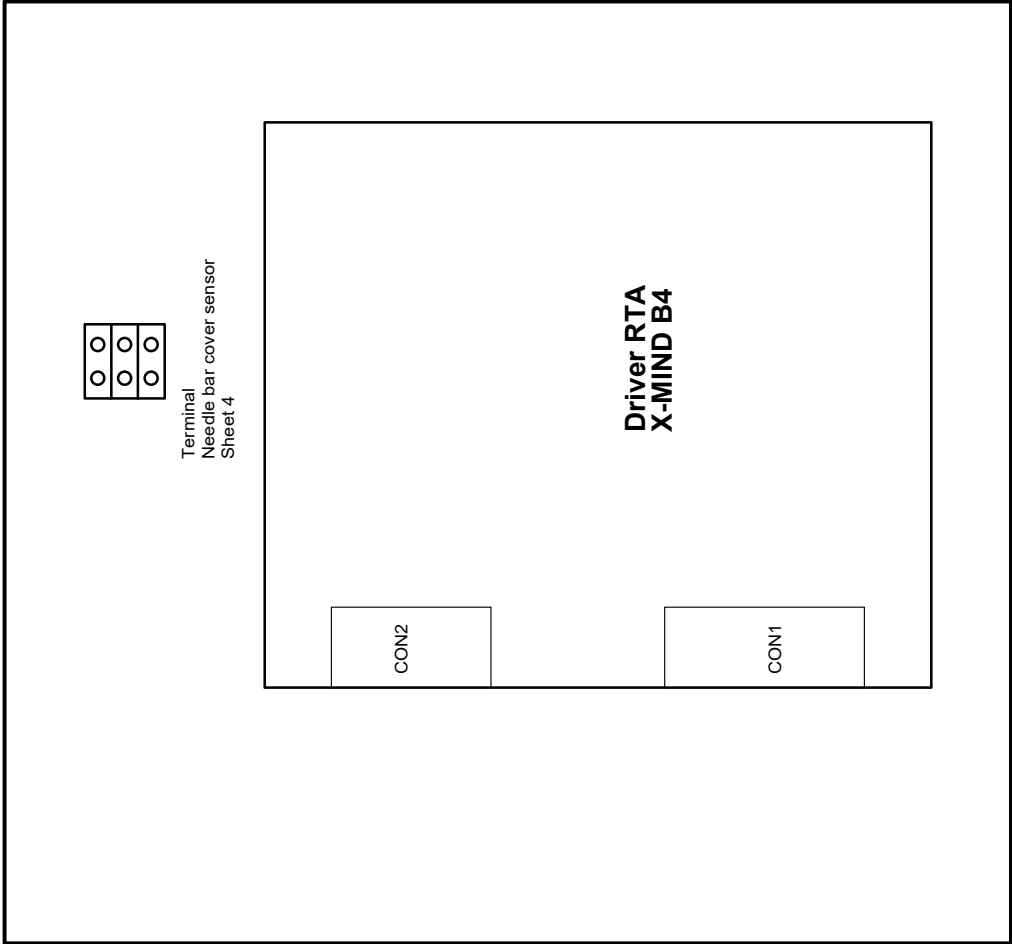

COVER SIDE VIEW



Title	3022 BHE Topographical arrangement		
Author	Falzi Giordano Vi.Be.Mac		
File	ico\Electric Diagram_3022_BHE_V1.0_ENG.dsn	Date	31/08/2017
Revision	1.0	Revision	1.0
Document		Sheets	5

19. PNEUMATIC DIAGRAM

19.1- Technical Pneumatic Diagram

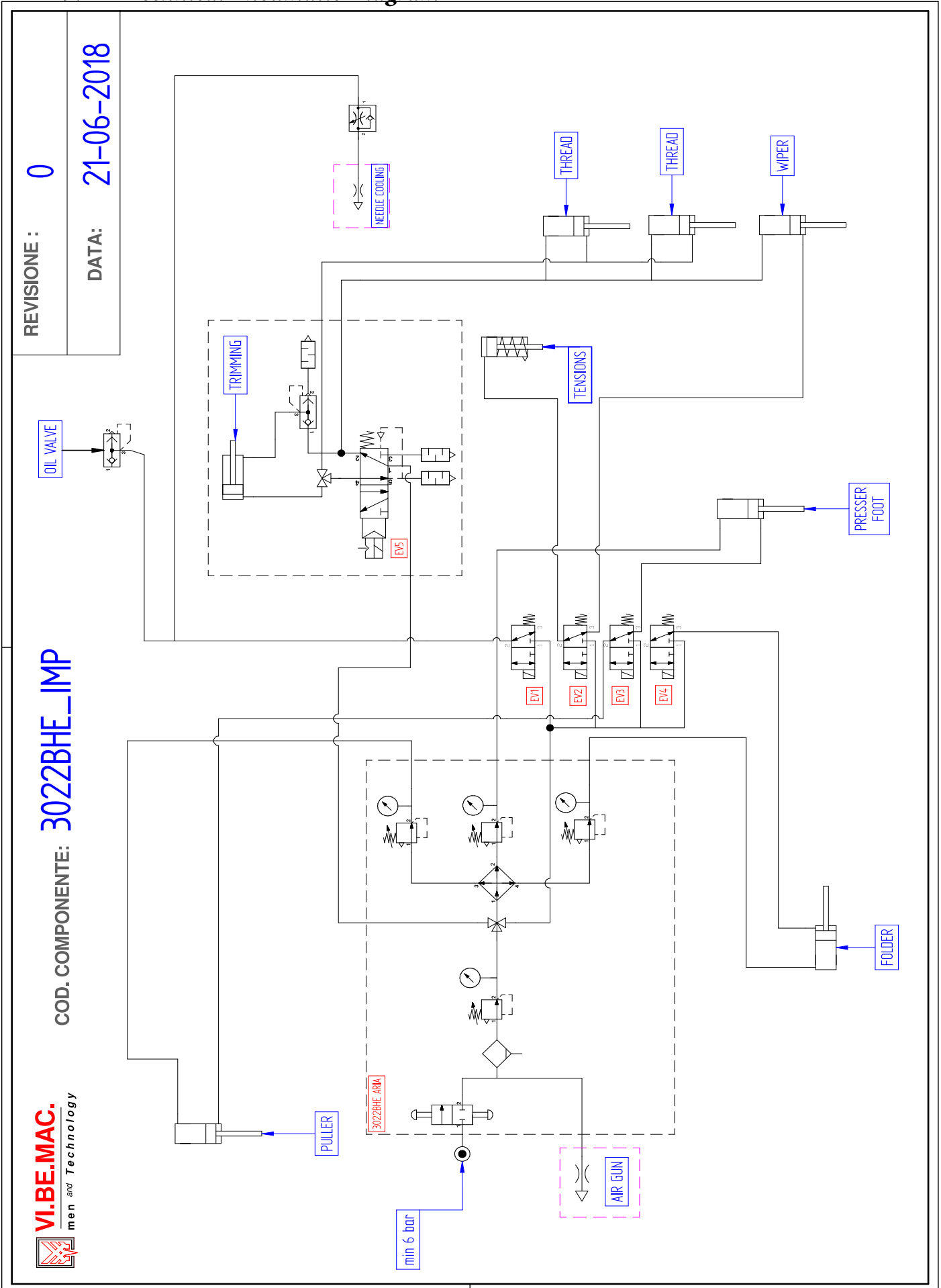

19.2- Topographic Pneumatic Diagram

REVISIONE : 0

DATA: 21-06-2018

COD. COMPONENTE: 3022BHE_IMP

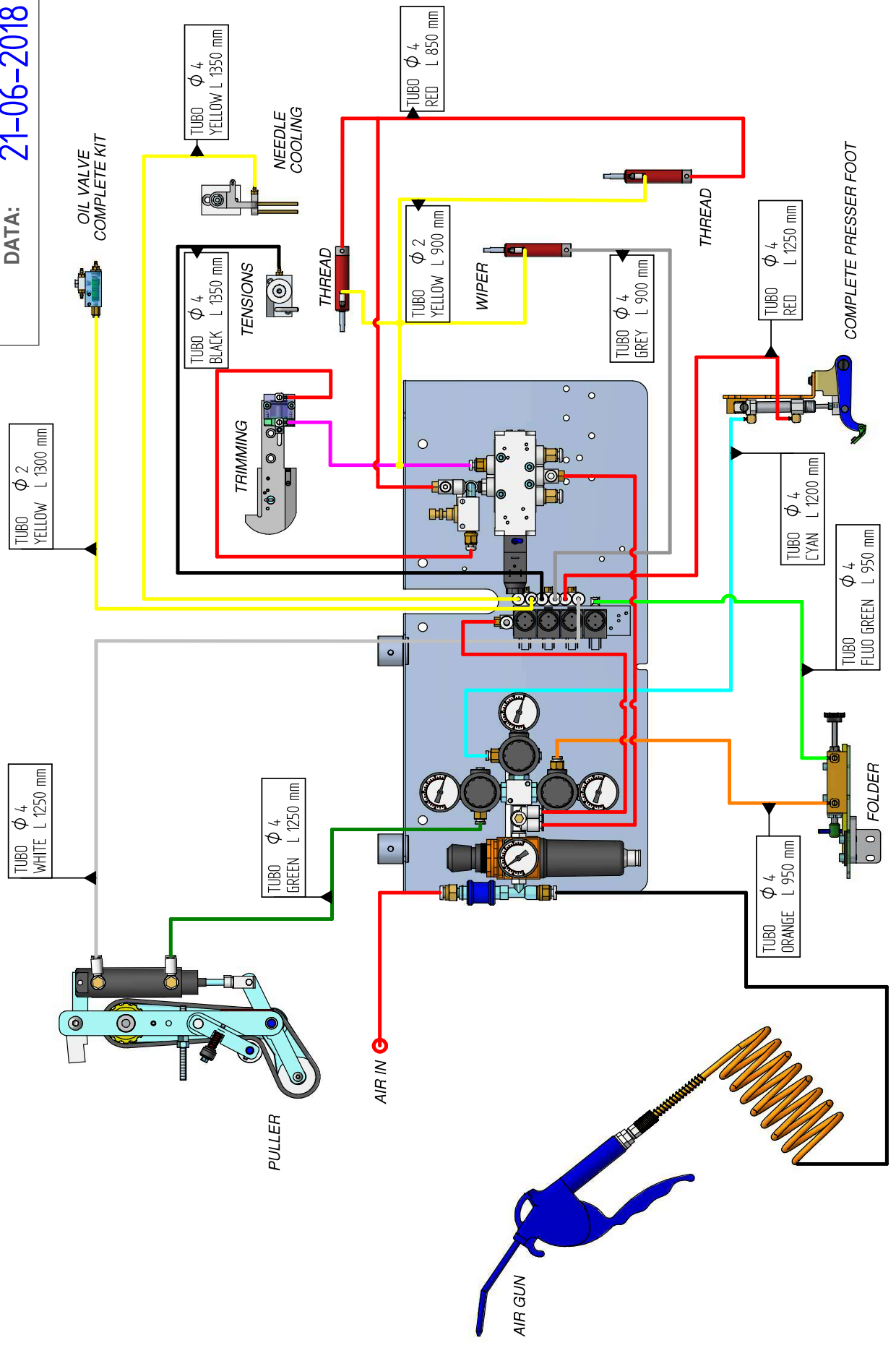

vbm  DISTRIBUTOR FOR:

 **V.I.B.E.M.A.C.**

Via Monte Pastello 7/i 37057
S. GIOVANNI LUPATOTO (VERONA), ITALIA
Tel. (+39) 045 8778151 - Fax (+39) 045 8779024
Web Site: www.vibemac.com Email: customercare@vbm-grp.com