

INSTRUCTIONS FOR THE MAINTENANCE OPERATOR 4650EV9@UP2 AUTOMATIC UNIT

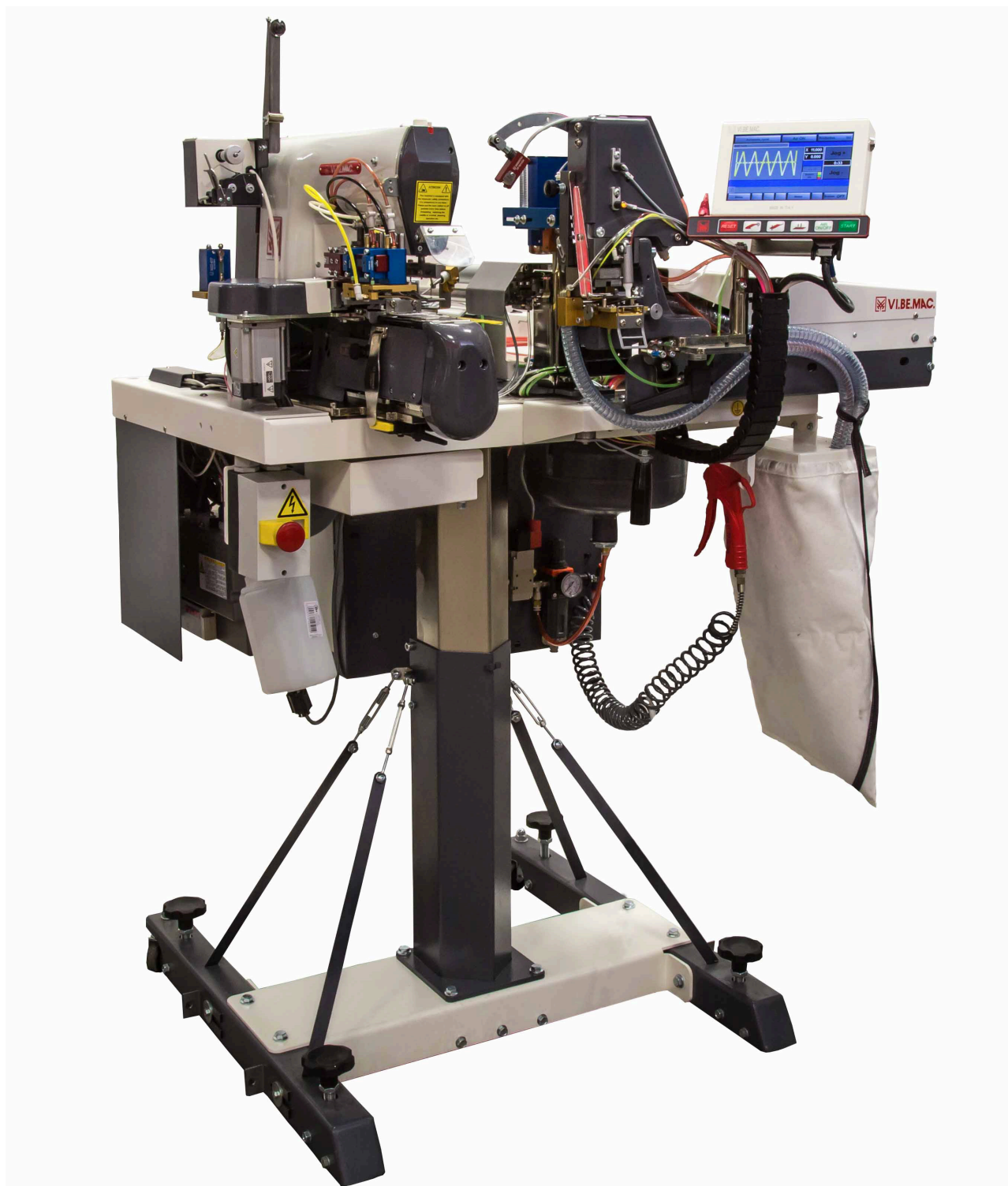

VI.BE.MAC. S.p.A.

Società soggetta a direzione e coordinamento di Jack Europe S.à.r.l.

Via Monte Pastello 7/i

37057 S. GIOVANNI LUPATOTO
(VERONA) ITALIA

Tel. (+39) 045 8778151

Fax (+39) 045 8779024

Email: customercare@vbm-grp.com
www.vibemac.com

ORIGINAL INSTRUCTIONS

Thank you for choosing a unit manufactured by VI.BE.MAC. S.p.A.

This unit has been designed and built using state-of-the-art technologies and procedures to ensure the best reliability over time and, at the same time, to ensure maximum operator safety.

Carefully read and comply with all information in this manual for proper and safe operation of the unit.

All documentation supplied with the unit - and in particular this manual - must be carefully preserved for future reference.



This publication or parts thereof may not be reproduced, stored in a storage machine, transmitted, transcribed or translated into any common or computer language, in any form or by any electronic, mechanical, magnetic, optical, chemical, manual or other means without express written authorisation from VI.BE.MAC. S.p.A.

VI.BE.MAC. S.p.A. provides a guarantee with respect to the contents of this publication, with express prohibition to use this publication itself for other purposes of any commercial, practical, technical-scientific nature unrelated to operation of the machine to which it refers, for which this publication was drafted.

Guarantee on the correctness of information contained herein is provided on condition that all the provisions contained in this documentation are strictly observed by the machine user. Furthermore, VI.BE.MAC. S.p.A. reserves the right to revise this publication and to make changes to its contents without any obligation to notify any person or organisation.

Said revised publications will be available upon request from VI.BE.MAC. S.p.A.

The original instructions manual was drafted in italian.

Declaration of CE Conformity

Translate Version

The company:

VI.BE.MAC. S.p.A.
Via Monte Pastello 7/i
37057 San Giovanni Lupatoto
VERONA - ITALIA
Tel. +39-045-8778151
Fax +39-045-8779024

In quality of manufacturer, declares under its responsibility that the product:

COMPANY: VIBEMAC
SERIAL NUMBER: XXXXXXXX

MODEL: 4650EV9@UP2
MANUFACTURED IN YEAR: 2017 twothousand and seventeen

DESCRIPTION: Automatic unit with a single sewing head with two needles, for the preparation, cutting, loading, and the application of a pre sewn belt loop on trousers, in a single sewing cycle. The unit is equipped with a digital panel for the control of the unit.

The present declaration has been issued according to machinery directive 2006/42/CE dated 17 May 2006 and to the following directive:

- Electromagnetic Compatibility 2004/108/CE

As required, CE mark is applied on the machine

PLACE AND DATE
SAN GIOVANNI LUPATOTO, 27/06/2017

C.E.O.
Alberto Guerreschi

Index

1.	INTRODUCTION	8
2.	CONDITIONS FOR USE	9
2.1-	Guarante conditions	9
3.	LIFTING AND TRANSPORT	10
4.	GENERAL DESCRIPTION	11
4.1-	General characteristics	11
4.2-	Technical specifications.....	11
4.3-	Dimension and weight.....	11
5.	INSTALLATION	12
5.1-	Unit positioning	12
5.2-	Flooring.....	12
5.3-	Mounting the unit	12
5.4-	Pneumatic supply.....	12
5.5-	Power supply.....	13
5.6-	Height	13
5.7-	Lighting	13
5.8-	Working position.....	13
6.	UNIT PARTS IDENTIFICATION	14
7.	DESCRIPTION OF THE COMMANDS.....	15
7.1-	Ignition.....	15
7.2-	Stop.....	15
7.2.1-	Emergency stop	15
7.3-	Left multi-purpose micro-switch	16
7.4-	Right multi-purpose micro-switch.....	16
7.5-	Additional light switch	16
8.	SELECTING THE LANGUAGE OF USE	16
9.	CONTROL PANEL	17
9.1-	SINGLE STITCH CYCLE.....	17
9.2-	Sewing sequence.....	18
9.3-	Control keypad buttons.....	18
10.	START UP	19
10.1-	Manual loop cutting	19
10.2-	Preparing a new loop	19
10.3-	Sewing a loop.....	19
11.	OPERATION MODE SELECTION	20
11.1-	Operation Mode – AUTOMATIC.....	20
11.2-	Operation Mode – SEMI-AUTOMATIC.....	20
11.3-	Operation Mode – MANUAL.....	20
12.	MAIN SCREEN FUNCTIONS	21
12.1-	Air On/Off	21
12.2-	Production	21
12.3-	Jog Button.....	22
12.4-	Bobbin	22
12.5-	Change program in use.....	23
13.	MENU.....	23
13.1-	Load the sewing program.....	24
13.2-	Creating a new program.....	25
13.3-	Deleting a program.....	27

13.4-	USB memory management.....	28
13.5-	Loading the sequence	30
13.6-	New sequence.....	30
13.7-	Delete sequence.....	32
14.	PARAMETERS.....	33
14.1-	Machine parameters	33
14.1.1-	Sewing area.....	34
14.1.2-	Double cut	35
14.1.3-	Parameters management.....	36
14.1.4-	Lock OFF menu button.....	37
14.2-	Special parameters	38
14.3-	Loop scrap.....	39
14.4-	Straightener enabling and disabling.....	40
14.5-	Extra feet pressure.....	41
14.6-	Timer list	41
14.7-	Machine info.....	43
15.	ALARM LOG	44
16.	TEST.....	44
16.1-	Input tests.....	45
16.1.1-	Inputs.....	47
16.2-	Output tests.....	50
16.2.1-	Outputs.....	51
16.3-	Cutting test	53
16.4-	Equipment test.....	54
16.5-	Memory status.....	54
16.6-	Motor test	55
17.	XLCE 554 SERVOMOTOR WITH XC GMFY PANEL.....	56
17.1-	Sewing speed.....	56
17.1.1-	High speed.....	56
17.1.2-	Low speed.....	57
17.1.3-	Setting the initial stitches	57
17.2-	Setting thread trimmer parameters.....	58
17.2.1-	Reset.....	59
17.3-	List of errors.....	60
17.4-	Test input e output.....	61
17.5-	Parameter setting	64
18.	LOOP CUTTING DEVICE	66
18.1-	Adjustment of the cutting device position	66
18.2-	Adjusting the loop guide.....	67
18.3-	Adjusting the loop scrap	67
18.4-	Loop scrap length adjustment	68
18.5-	Adjusting the cutting system.....	68
18.6-	Adjusting the movement of the cutting cylinder.....	69
18.7-	Adjustment of the flatness of the loop cutting cylinder	69
19.	LOOP PULLING DEVICE	70
19.1-	Adjustment of the loop pulling cylinder position	70
19.2-	Adjustment of the loop length cylinder.....	71
20.	LOOP LOADING DEVICE	71
20.1-	Loop forking.....	71
20.2-	Loop forking position	72
20.3-	Loop stopper position on the clamping device.....	73

20.4-	<i>Adjusting the intermediate stop of the carriage</i>	74
20.5-	<i>Adjusting the maximum forward position of the loop carriage</i>	75
20.6-	<i>Adjustment of the height under the feet</i>	76
20.7-	<i>Carriage return speed adjustment</i>	77
21.	LOOP STRAIGHTENER	77
22.	SEWING HEAD ADJUSTMENTS	78
22.1-	<i>Adjustment of the rotary hook phase</i>	78
22.2-	<i>Adjusting the thread trimmer</i>	79
22.3-	<i>Adjusting the thread trimmer spring</i>	81
22.4-	<i>Adjustment of the movable knife closing regulator</i>	81
23.	ADJUSTMENT OF THE FEET	82
23.1-	<i>Longitudinal adjustment</i>	82
23.2-	<i>Transverse adjustment</i>	82
23.3-	<i>Positioning of the foot</i>	83
24.	FUNCTIONING OF THE THREAD CATCHER	83
25.	CHANGING THE SIZES OF THE LOOP	84
25.1-	<i>Changing the length of the loop</i>	84
25.2-	<i>Replacement of the transport plate</i>	84
25.2.1-	<i>Positioning of an additional head</i>	84
25.2.2-	<i>External needle clamp position</i>	85
25.2.3-	<i>Position of the external foot</i>	85
25.2.4-	<i>Adjustment of the clamping device distance</i>	85
25.2.5-	<i>Adjustment of the loop cutting assembly position</i>	86
25.2.6-	<i>Adjustment of the loop pulling cylinder</i>	86
25.2.7-	<i>Adjustment of the loop straightener</i>	86
25.3-	<i>Changing the width of the loop</i>	86
26.	CLEANING AND MAINTENANCE	87
26.1-	<i>Lubrication of the rotary hook</i>	87
26.2-	<i>Lubrication and maintenance of the needle bar</i>	87
26.3-	<i>Maintenance of the X and Y axis</i>	88
27.	TROUBLESHOOTING	89
27.1-	<i>Control panel</i>	89
28.	ELECTRIC DIAGRAM	90
29.	PNEUMATIC DIAGRAM	105

SAFETY SIGNALS

	ELECTRICAL SHOCK DANGER: BEFORE OPENING THE COVER OR DOING THE OPERATION SWITCH OFF THE MAIN POWER
	MECHANISM MOOVING: BEFORE PERFORMING THE OPERATION, MAKE SURE THAT THE UNIT IS COMPLETELY STOPPED AND THE MAIN SWITCH IS TURNED OFF
	DANGER: BE SURE TO FOLLOW THE INSTRUCTION
	DANGER: THE TEMPERATURE WILL BE OVER 70C°-160F°
	DON'T REMOVE SAFETY PROTECTIONS
	DON'T LUBRIFICATE OR ADJUST WHILE MOVING
	TURN OFF THE MAIN POWER SWITCH BEFORE OPERATING ON THE UNIT
	THE USE OF EAR PROTECTION IS MANDATORY
	IT IS MANDATORY TO USE THE GOGGLES

1. INTRODUCTION

Proper and safe operation of the unit is only ensured if used in accordance with the information stated in this manual and, in general, in the documentation accompanying the machine. It is therefore imperative to carefully read and store all relevant documentation.

It is always necessary to ensure that all operators have fully understood the rules of use. The company is not responsible for any damages to persons or property arising from improper use of the machine.

Do not remove or damage labels, writing, and warnings on parts of the machine. Should it be necessary to restore them, contact VI.BE.MAC. S.p.A.

VI.BE.MAC. S.p.A. disclaims any and all liability for a failure to observe the safety and prevention rules outlined in the various sections of this manual and for any damage caused by improper use.

The machine covered by this manual has been designed and manufactured in accordance with applicable laws and the state of the art valid at the time of delivery. It is the responsibility of the customer to make continuous adjustments to enable its constant compliance with the legal requirements and regulations in place at the installation site.

Any modification to the machine must be previously authorised by VI.BE.MAC. S.p.A.

All work on the machine (maintenance, adjustments, repairs, cleaning) must be carried out by appropriately trained personnel and as indicated in this manual.

Storing the manual

This instructions manual is an integral part of the machine and must be stored for any future reference.

It is advisable to:

- Store the manual in an accessible place known to all operators which is protected from moisture and heat and protected from direct sunlight.
- Utilise the manual so as to avoid damaging all or part of its contents: do not remove, tear or modify parts of the manual for any reason.

In the event of sale or transfer of the machine to another person, this manual and its attachments must be delivered to the new user.

2. CONDITIONS FOR USE

All operations that comply with the following conditions are considered “normal”:

- the user applies all instructions in this manual and CE directives
- all safety standards are respected, not removing the casing or safety catches installed by the manufacturer
- the power supply is constant and does not fluctuate by more than 10%
- the unit has to be connected under an automatic cut-out switch of 30mA
- the unit is connected to an earthing system in order to prevent disturbances or electric shocks
- the unit is connected to an electric circuit with separate NEUTRAL and EARTH wires
- the unit is not used at high temperatures (over 40°C) or low temperatures (below 10°C)
- water or other fluids are not permitted to enter the motor
- water or other fluids are not permitted to come into contact with the control card, the solenoid valves and the cylinders
- the machine is not used in the presence of explosive gases, dust or oil fumes
- the machine is not connected to a compressed air system containing water or other fluids in the pressurized circuit
- the unit is connected to a compressed air system with minimum constant internal pressure of 5.5 bar
- the unit is installed in a factory not over 1000 mt from sea level
- the unit is installed on a flat service with no inclination
- only qualified personnel are permitted to commission the machine and carry out extraordinary maintenance work

The manufacturer declines all responsibility for damage caused to people or things by the machine if:

- the machine was not commissioned by qualified personnel
- any repairs to the machine were not made by qualified personnel
- the power supply is not constant or does not correspond to requirements
- the machine is not earthed, or there are electronic problems in the electrical system
- the motor has not been subjected to the scheduled maintenance operations
- original or model-specific spare parts have not been used
- the user demonstrates total or partial failure to observe the instructions
- rain or snow get in contact with the unit

It is absolutely prohibited to:

- **remove the casing and** safety devices from their positions, thereby posing a risk to the user
- remove the eye protection mirror without equipping the user with special eye protection glasses in compliance with the law
- deactivate the safety catches installed by the manufacturer, thereby posing a risk to the user
- make changes to the machine without authorization from the manufacturer, thereby posing a risk to the user
- **exceptional circumstances**

2.1- *Guarante conditions*

All unit components have a 1 (ONE) year guarantee and should be send to the manufacturer for inspection if found to be defective.

All pieces damaged due to negligence of the end user and/or incorrect adjustments to the unit, carried out by unqualified personnel, will NOT be recognized as defective and will not be covered by the guarantee. These will be charged at the normal price, including consequent delivery and/or installation costs.

3. **LIFTING AND TRANSPORT**

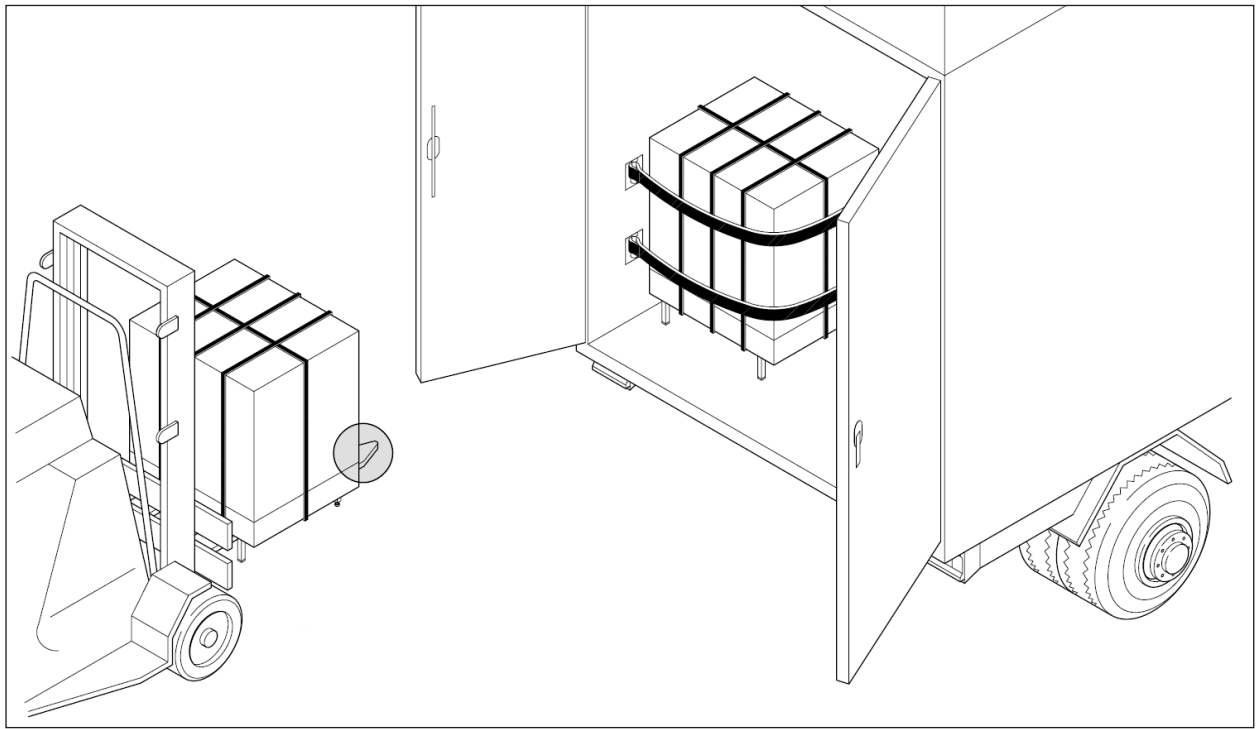

Make sure that during lifting the whole machine rests on the forklift forks.

Position on the truck surly fixed with straps or balts that will insure the stability during the transport

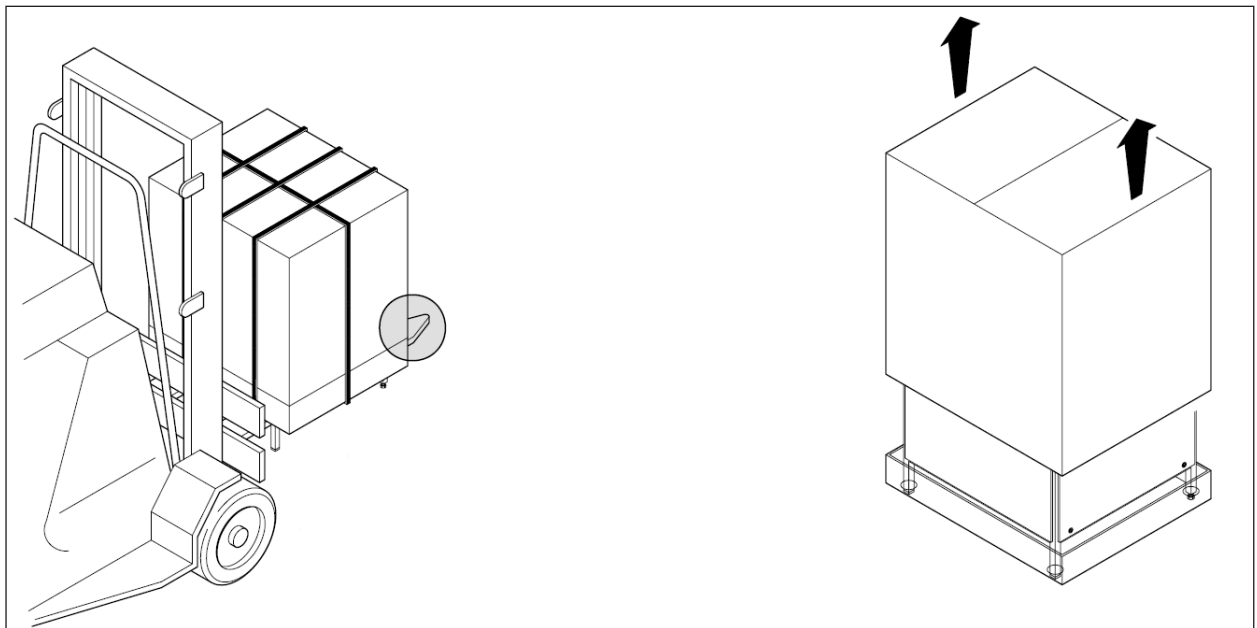

Make sure that during unloading the whole machine rests on the forklift forks. Place it on a hard flat surface repaired from weather.

Remove straps, and loosen the fixing screws, remove the top part of the packing box by pulling it upwards.



WARNING!
THE UNIT MUST BE UNPACKED ON A FLAT SURFACE AND FREE FROM ROUGHNESS

4. GENERAL DESCRIPTION

4.1- General characteristics

The 4650EV9@UP2 automatic unit **is used to prepare and attach loops** along the **waist-band** of jeans trousers, casual, classic and work trousers, and is composed of the following main groups:

- The VI.BE.MAC. S.p.A. sewing head, with a two needle clamp, two rotary hooks with large bobbin, for the contemporary and personalized realization of several seams on a loop.



- The device for the preparation and loading of the loops
- Touch-screen **panel** and CPU CARD
- Two stepper motors for X- and Y-axis with respective OMRON drivers
- Main motor MITSUBISHI XL-CE 554 with control panel model GMFY

The loop already sewn is pulled by the loop pulling cylinder to give a controlled length, then is cutted in a V shape by the loop cutting cylinder, folded on the edges or one edge depends on the type of the loop that is necessary and then is sewn on the waist-band. The loop can be prepared in different types: the standard type, the semi-classic type and the classic type (for these procedures there are optional devices supplied as standard with the unit). The unit is equipped with a touch screen Control Panel the is working togheter with the CPU board and is used to select different functions and features of the machine:

- selection of the working procedure
- start of the preparation cycle of the loop
- Resetting the loop preparation cycle (RESET) to zero
- manual operation of the presser foot
- search for the home position of movement axis
- Sewing stitch programming
- recall programs or possible changes with the data from the memory
- **execution of the parameters for the work of the device for the preparation of the feed-through**

The GMFY control panel allows you to control:

- starting and stopping the sewing cycle
- the sewing speed
- the trimmingo fthe thread

needle gauge	min 20mm
	max 80mm
sewing area	28x15mm
needle type	134MR BALL-SUK (ball point)
number of stitches	programmable from 1 to 999

4.3- Dimension and weight

with packaging	
Width	101 cm
Length	118 cm
Height	118 cm
Weight	258 Kg

without packaging	
Width	84 cm
Length	104 cm
Height	150 cm
Weight	214 Kg

5. INSTALLATION

Installation must be carried out by VI.BE.MAC. S.p.A. technician or authorised by it. In addition, the customer must arrange the place where the installation is carried out in a manner appropriate to the needs of the unit in all positions assumed by the moving parts of the same, as illustrated in this manual, in accordance with the technical characteristics and the need for space suitable for the necessary maintenance/adjustments.

5.1- Unit positioning

The area available for installation must be determined taking into account the overall dimensions and the space required for the use and maintenance of the unit. Its position in relation to fixed obstacles shall be such as to allow easy passage for use and maintenance; in particular, the minimum space for the passage of persons shall be 650 mm. The minimum distance between moving parts and fixed obstacles must be 500 mm, so as to avoid crushing the body

5.2- Flooring

The user must prepare for the housing of the unit a compact, smooth and horizontal concrete floor suitable to support the weight of the machine and to ensure its stability.

5.3- Mounting the unit

The unit is delivered to the customer already assembled in its basic parts; during the transport and handling phase it is disconnected from the power supply and pneumatic, it will be connected in the assembly phase. The fixing and levelling of the elements that make up the unit are carried out by authorized personnel of VI.BE.MAC. S.p.A. In particular:

- the unit is equipped with support points for positioning and levelling, as shown in figure (A)

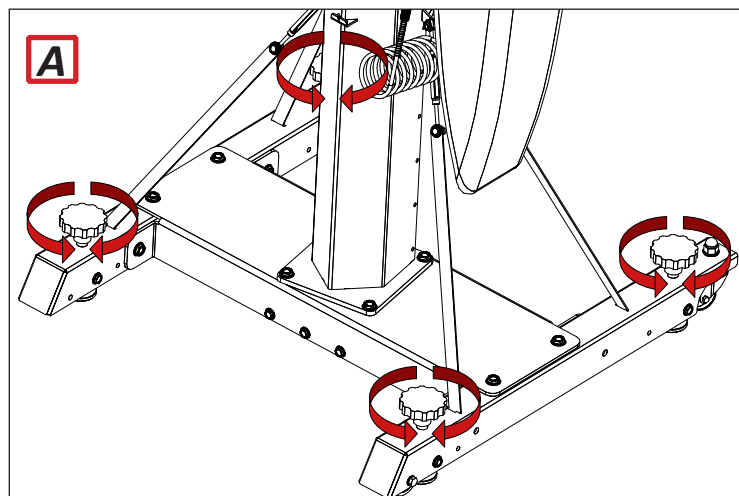

5.4- Pneumatic supply

Connect the unit pneumatically with a minimum pressure of 6 bar. The consumption, at its maximum operating capacity, is 6 litres of air per minute, with a constant internal working pressure of 4.5 bar (adjustable by the main air regulator). By acting on the left regulator it is possible to vary the loading speed, which must be between 1.8 and 2.4 bar. Through the sliding valve (see figure B) it is possible to supply or discharge the unit pneumatically.

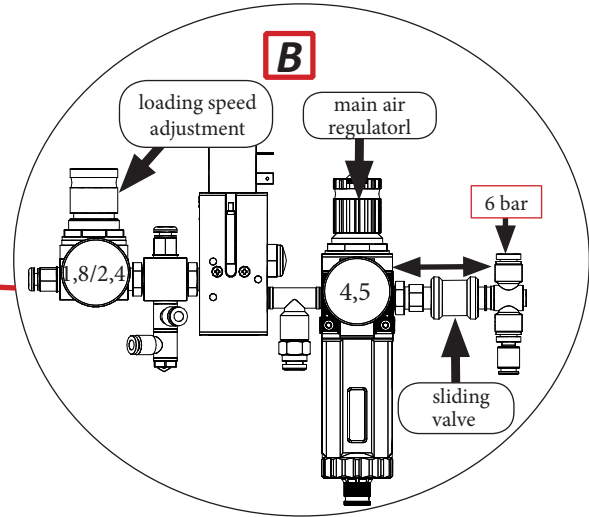
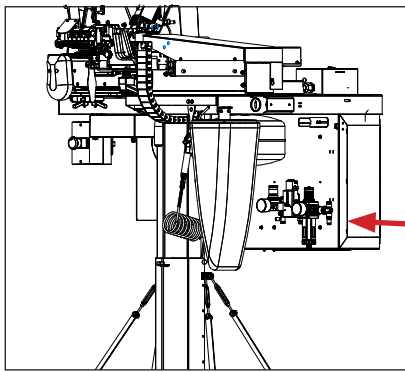

5.5- Power supply

POWER SUPPLY	
Voltage	220V ± 10%
Frequency	50/60 Hz ±2%
Total power	800 W ± 10%

5.6- Height

The height of the unit's is adjustable and can be modified depends on the height of the operator. To adjust the working plane, use the knob underneath the working plane.

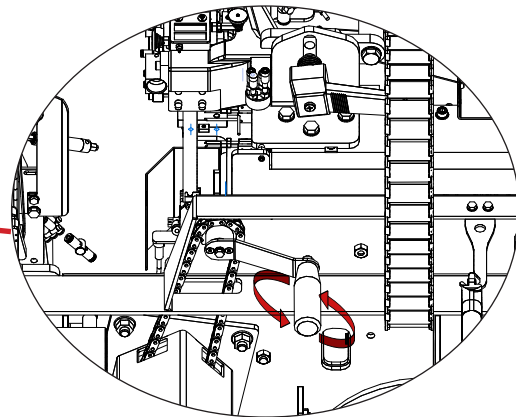
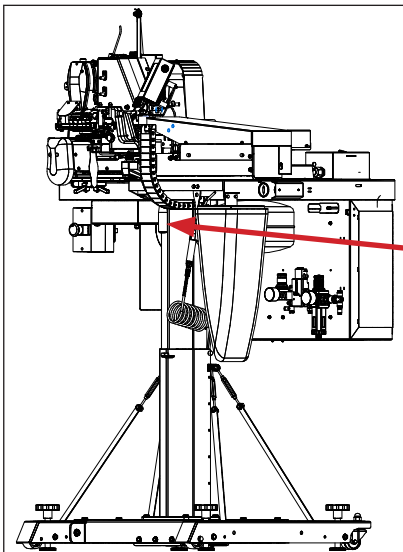

5.7- Lighting

The purchaser must ensure that the lighting of the working area is sufficient to allow a clear view of the operations and all parts of the machinery; in particular, areas of shade, glare and irritating stroboscopic effects must be avoided. The unit is also equipped with an additional light that can be switched on with the switch shown in the figure on the next page when the operator is working.



WARNING!

IT IS IMPORTANT TO KNOW THAT THE ADDITIONAL LIGHT WILL ALSO WORK WHEN THE UNIT IS SWITCH OFF TO ALLOW TECHNICAL MAINTENANCE TO BE CARRIED OUT.

5.8- Working position

The operator will carry out his working operations positioned in front of the sewing head .



WARNING!

FOR MAXIMUM PRODUCTIVITY IT IS RECOMMENDED TO CARRY OUT THE WORK IN A STANDING POSITION

6. UNIT PARTS IDENTIFICATION

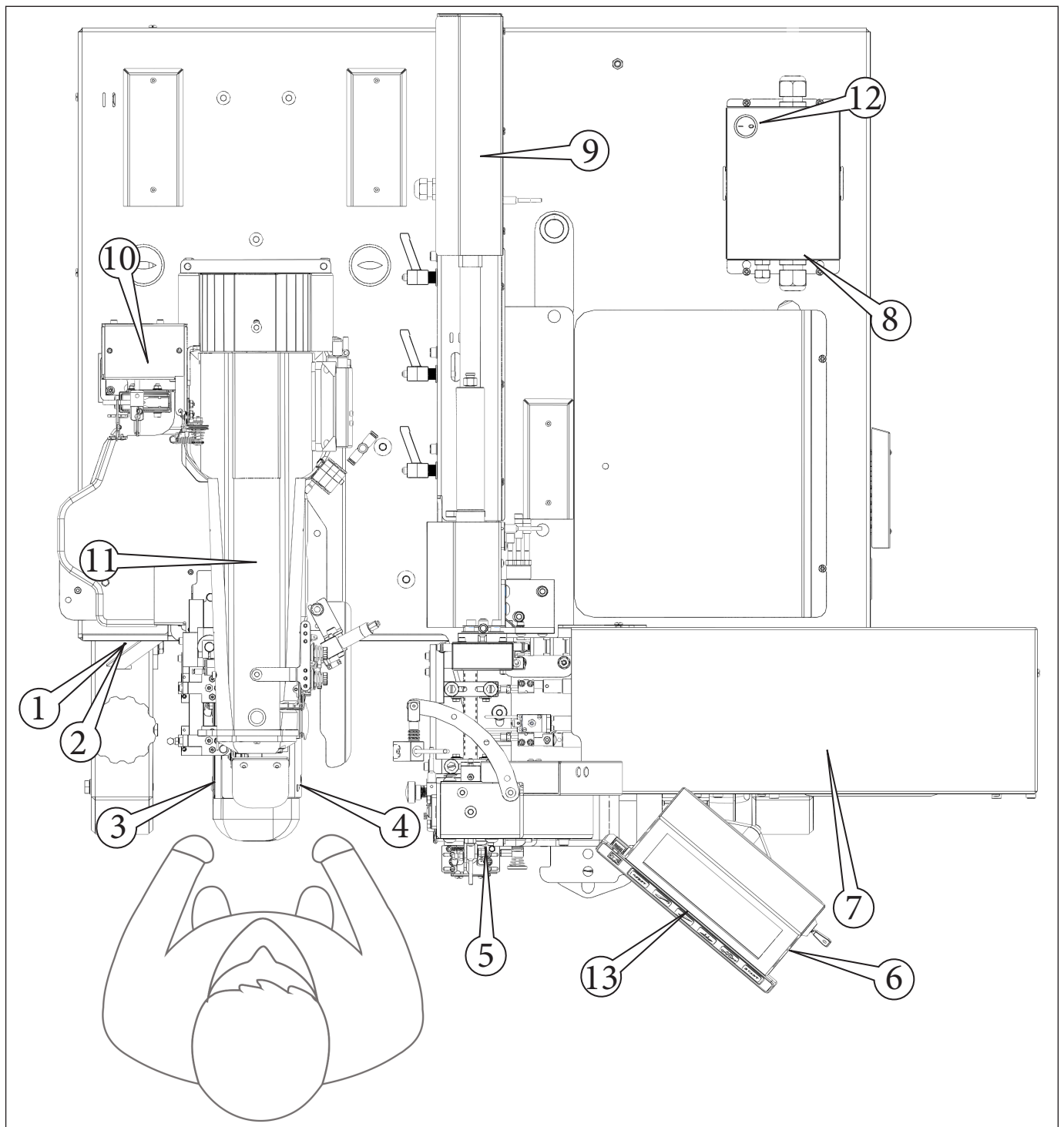

- | | |
|--------------------------------------|----------------------------|
| 1. Emergency button | 8. Overvoltage box |
| 2. Switch ON button | 9. Loop pulling device |
| 3. Left multi-function micro switch | 10. Bobbin winder |
| 4. Right multi-function micro switch | 11. Sewing head |
| 5. Loop cutting device | 12. Light switch |
| 6. Touch screen Control panel | 13. Keypad control buttons |
| 7. Loop loading device | |

7. DESCRIPTION OF THE COMMANDS

7.1- Switching ON

To switch on the unit after it has been connected to a power source, press the black button on the left side of the stand near the red emergency stop button. The following screen will appear after the black button is pressed.

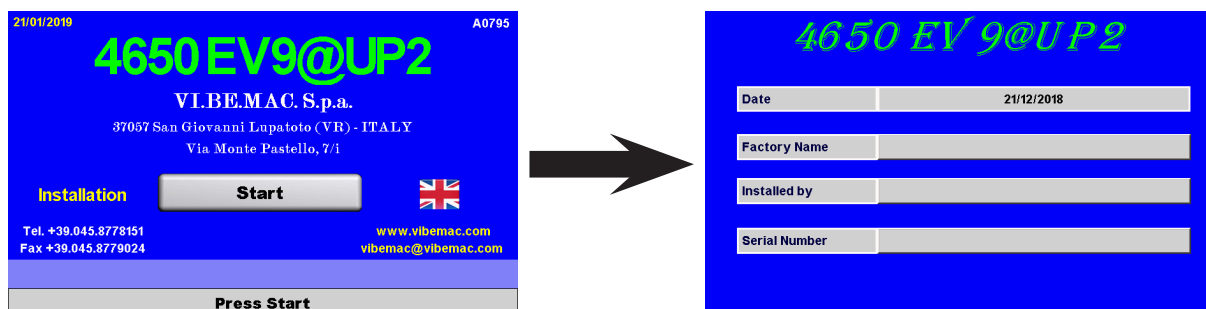

Next we have to press the “START” button and it will appear the page where you have to enter the required information to finish the installation. (N.B. This page will appear only the first time the unit is turned on, and usually the required data is entered by VI.BE.MAC S.p.A. staff or authorized by it during the installation) Every time the unit is switched on, the following screen will appear and the information from the above page will not be requested anymore.



7.2- Switching OFF

To switch OFF/stop the unit press the button  on the “Keypad control buttons” together with the left multi-function micro switch, and then the red button “Emergency stop”.

7.2.1- Emergency stop

In case of emergency PUSH the red emergency stop button, which will interrupt both the electrical and pneumatic power supply. In this situation the air from ALL MOVABLE PARTS WILL BE RELEASED and some of them will return to the original position. To unlock the unit when the emergency has ended, turn the red emergency button clockwise.

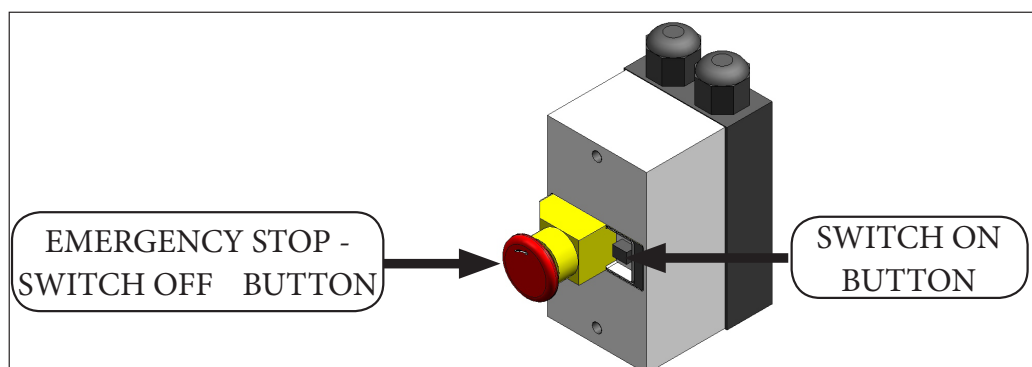

7.3- *Left multi-function micro-switch*

It is on the left under the unit's sewing head and allows for the various functions explained later.

7.4- *Right multi-function micro-switch*

It is on the right under the unit's sewing head and allows for the various functions explained later.

7.5- *Light switch*

It is positioned above the OVER VOLTAGE DEVICE and is used to turn on the additional light to ensure adequate lighting on the work area.



CAUTION !!!

IT IS IMPORTANT TO KNOW THAT THIS LIGHT WILL ALSO WORK WITH THE MACHINE SWITCHED OFF TO ALLOW TO BE PERFORMED THE TECHNICAL MAINTENANCE

8. *SELECTING THE LANGUAGE OF USE*

The control panel (6), allows the operator to select the language of use from 8 types: Italian, English, Spanish, Portuguese, Turkish, Russian, Arabic and Chinese. After the unit is switched on, the initial screen appears where it is possible to change the language by pressing on the flag on the right side of the START button. Next the language selection page will be displayed, see below, and pressing on the desired language it will be selected the necessary language.



Press to select the language



9. CONTROL PANEL

The control panel with “TOUCH-SCREEN” technology allows the user to have a complete interface, with intuitive screens for maximum ease of use and management of the unit.

Below is a summary of the main functions:

- possibility to choose between 9 standard sewing patterns or personalised custom programs;
- different stitching sequences, maximum 10 different types per sequence, with the possibility of adding/removing/modifying the sequence programs;
- reading of programs saved in the memory;
- setting of production count and bobbin change count;
- selection of the operating mode for the preparation of the loops in the equipment;
- activation/deactivation of the compressed air circuit;

The display on the screen is different based on the sewing operations called up:

- ONE TYPE STITCH CYCLE
- MULTI TYPES STITCH SEQUENCE

9.1- ONE TYPE STITCH CYCLE

For this working way the operator has the following commands available:

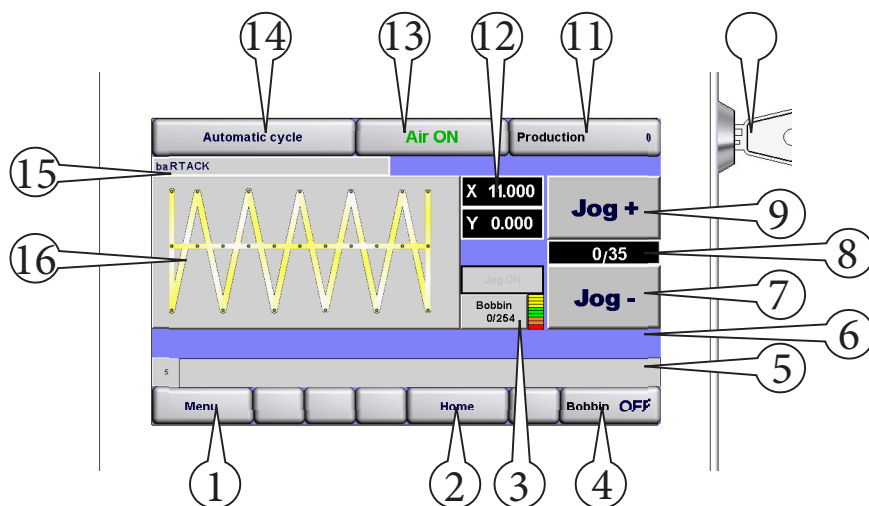

1. Is used to access all the unit's functions menu
2. Combined with the Left multi-function micro switch, it is used to move to the zero position of the X and Y axes
3. If set, it shows how much thread remains in the bobbins (the number on the left indicates the stitches sewn/ the one on the right indicates the total available stitches that can be done with the thread in the bobbin)
4. Keep pressed for more then 3 sec to enable or disable the bobbin count function
5. Displays the helping messages
6. Displays the errors and alarms
7. Combined with the Left multi-function micro-switch, it is used to check step by step the stitches of the displayed program in the reverse way
8. Displays how many stitches have been made from the total stitches of sewing program in use
9. Combined with the Left multi-function micro-switch, it is used to check step by step the stitches of the displayed program in the forward way
10. It is used to enable functions reserved for qualified technicians
11. Partial production counter. It can be reset by pressing for more then 3 sec
12. Position in millimetres of the X and Y axis
13. Used to activate/deactivate the unit's pneumatic circuit
14. If is pressed for more then 3 sec, it will change the working method (automatic/semi-automatic/ manual)
15. Displays the name of the sewing program in use
16. Displays and allows to modify the measurements of the program in use

9.2- Multi types stitch sequence

When this operation way is selected, the screen will show the following buttons:

17. Load the next program in the sequence, useful in the case of failed stitching.
18. Reset the sequence by loading the first program.
19. Load the previous program in the sequence, useful in the case of failed stitching.
20. Displays the name and number of the program running
21. Displays the name of the sequence

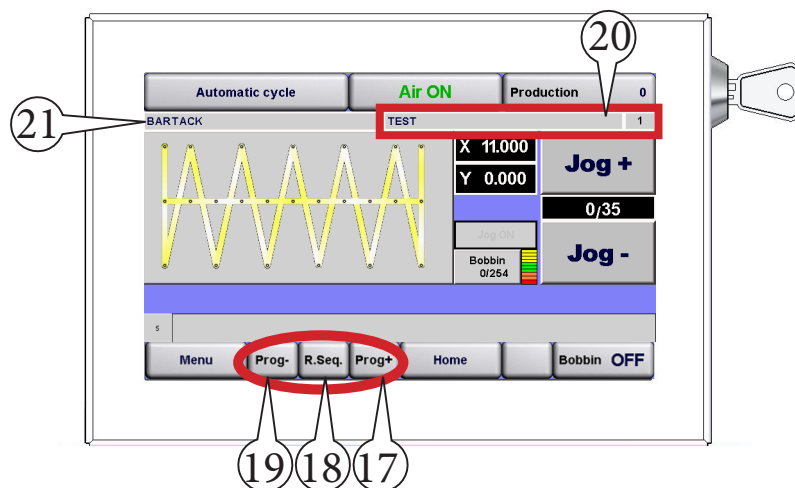

9.3- Control keypad buttons

Positioned under the touch screen panel, it has six buttons that combined with the left multi-function micro-switch (see IDENTIFICATION OF UNIT PARTS chapter for its position) will perform the operations listed below:

- button 22: Reset the unit's equipment
- button 23: Starts the loop formation cycle
- button 24: Manual loop cutting
- button 25: Manual presser foot down, if is preset during the stitching it will remain down after the sewing is finished
- button 26: Activate or deactivate the unit's pneumatic circuit
- button 27: It is used to start the unit once it is switched on

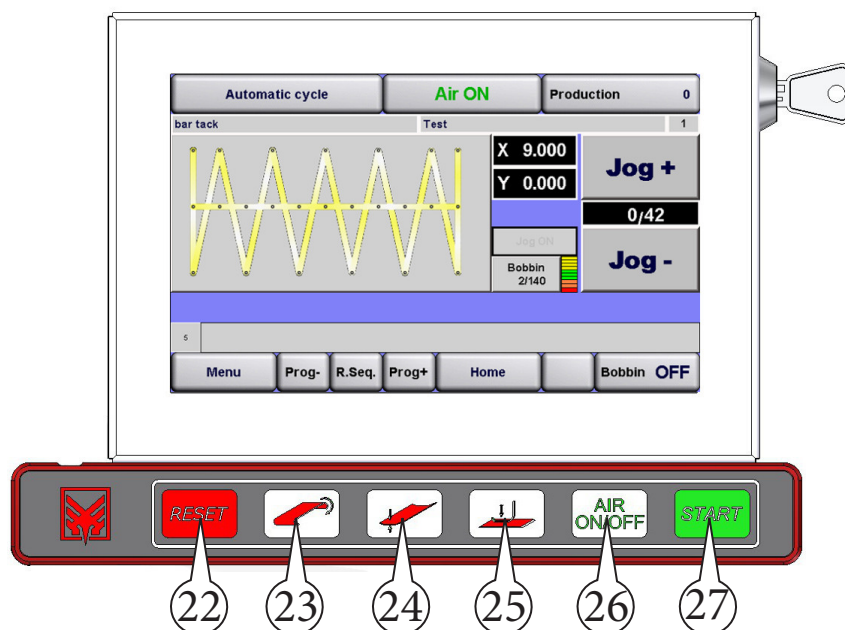

CAUTION !!!

IF THE SCREEN ACCIDENTALLY GET DAMAGED, THE MACHINE WILL WORK ONLY WITH THE KEYPAD FUNCTIONING WITH THE BASIC OPERATIONS

10. START UP

It is important that the description to be read carefully and understood, since the guide for the elimination of accidental defects is based on the knowledge of the operating sequence

10.1- Manual loop cutting

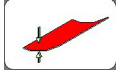
To perform the first loop cutting cycle, press the left multi-function micro-switch from the sewing head and at the same time press the  button on the “control keypad buttons”.

10.2- Preparing a new loop

To prepare the loop, press the left multi-function micro-switch from the sewing head and at the same time press the  button on the “control keypad buttons”.

10.3- Sewing a loop

After carrying out the Manual cutting and Preparation of the loop, press both multi-function micro-switches under the sewing head to load the loop under the presser foot and start the sewing cycle.

11. SELECTING THE FUNCTIONING MODE

By pressing THE UPPER BUTTON shown in the image, it is possible to select from three different types of functions.

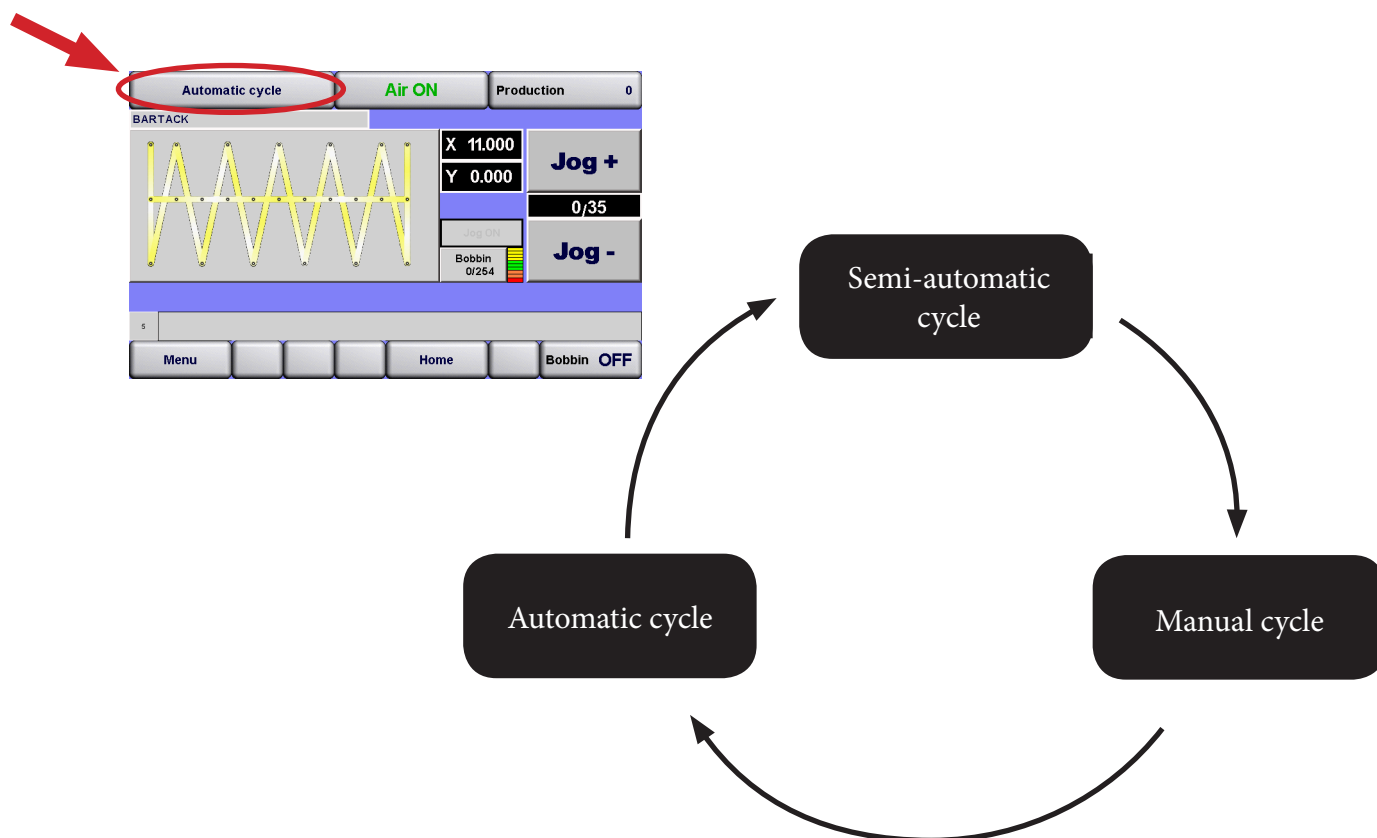

11.1- Functioning Mode – AUTOMATIC CYCLE

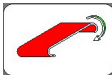
Press the left multi-function micro-switch +  to prepare a new loop, in this way the loop loader moves to the intermediate stop position. After pressing both multi-function micro-switches, the loop carriage moves under the presser foot and the sewing cycle begins. The loop loader returns all the way back, the preparation sequence of another loop starts automatically.

11.2- Functioning Mode – SEMI-AUTOMATIC CYCLE

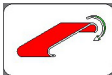
Press the left multi-function micro-switch +  to prepare a new loop, in this way the loop loader reaches the intermediate stop position. By pressing both multi-function micro-switches, the loop loader moves to the sewing position. Therefore, the operator has the possibility of checking the position of the loop on the trouser. By pressing the two multi-function micro-switches for the second time, the presser foot lower and the sewing cycle begins. The loop loader returns all the way back, and the preparation sequence of another loop starts automatically.

11.3- Functioning Mode – MANUAL CYCLE

By pressing both multi-function micro-switches, the presser foot will lower and the unit will carry out only the sewing cycle.

NOTE: IN THIS OPERATING MODE, THE LOOP CUTTING, LOOP PULLING LOOP LOADER DEVICE DO NOT WORK.

12. MAIN SCREEN FUNCTIONS



12.1- Air On/Off

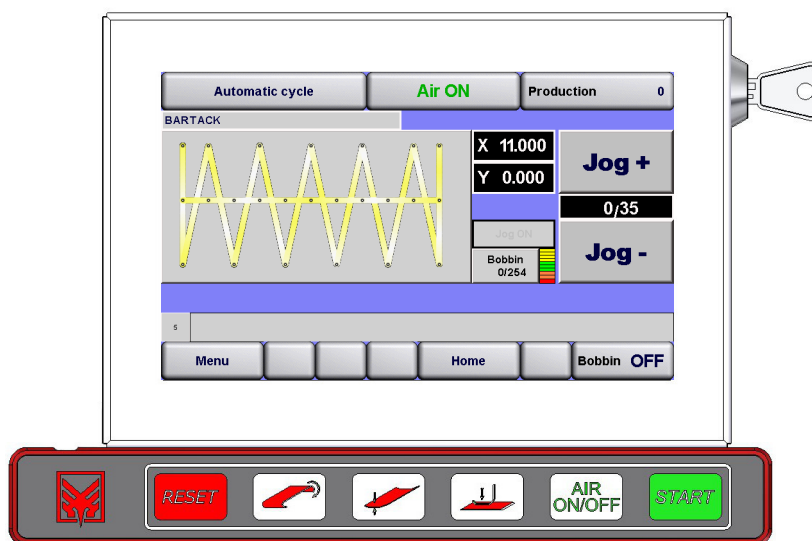

By pressing and holding either on the LCD screen or on the control keypad together with left multi-function micro-switch the air pressure will be turn on/off.

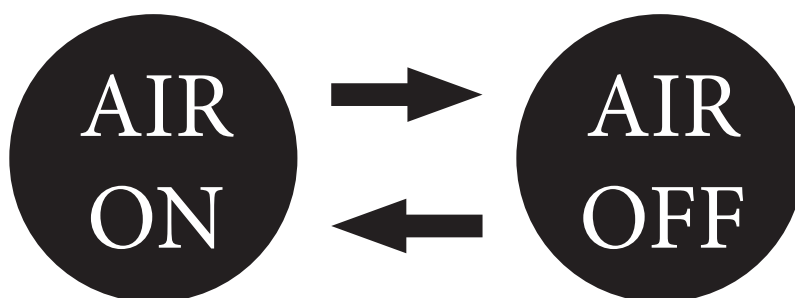

12.2- Production counter

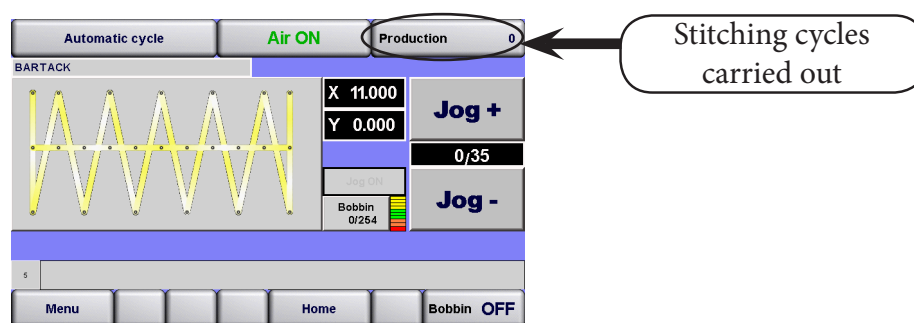

The production counter counts the sewing cycles performed by the unit.
The production counter can be reset by pressing for 3 seconds the PRODUCTION button.

12.3- Jog Buttons

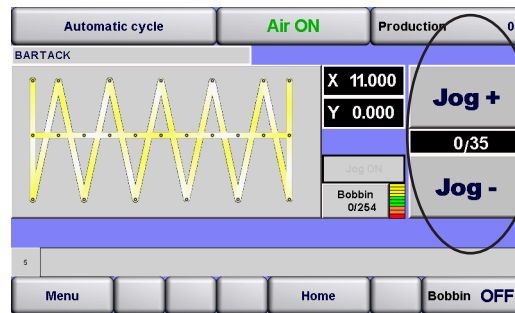

this counter will show the number of stitches in the sewing program and the position where the stitching is located

To activate the JOG mode, press the left function-purpose micro-switch and the Jog + button on the panel. Press JOG + or JOG - to follow the step by step the sewing program, 1 stitch at a time without sewing.

To exit the JOG mode, press the left multi-purpose micro-switch + **RESET** on the key pad. The X and Y will move back the position 0 of the sewing program.

12.4- Bobbin counter

This function can be turned on/off by holding down the BOBBIN ON/OFF button. The message will change from OFF to ON to signal the activation.

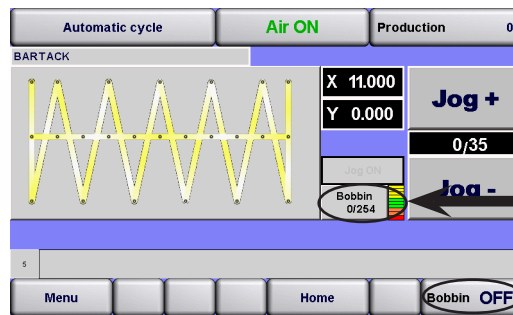

Bobbin counter indicator

Turning the bobbin counter on/off

The screen also shows the bobbin count current value. The bobbin counter parameters can be set by pressing the BOBBIN COUNT INDICATOR button. The following screen will be shown:

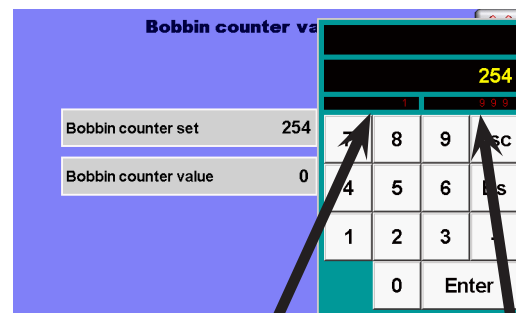
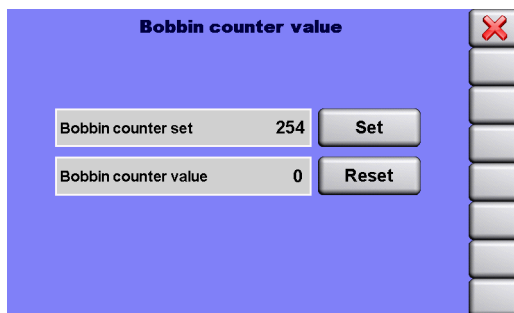

minimum value

maximum value

To enter a correct value, proceed as follows:

- press SET
- enter a high value, e.g. 999 (the value must be multiplied by 10. So it will be 9990)
- press Enter
- the Bobbin counter value is reset by pressing Reset,
- load a new complete thread loaded bobbin in the rotary hook,
- press X to exit.

Perform the sewing cycles until the thread on the bobbin ends, after which press the BOBBIN ICON again from the work screen; at this point, it will be noted that the BOBBIN COUNT value has increased, e.g. 180. At this point, set the BOBBIN COUNT SETUP function at less than 180, when the set value is reached the machine will stop with a message on the screen remembering to reload the bobbin; press the message to reset it.

12.5- Modify the sewing program in use

The program can be changed by pressing on the image shown in the figure down

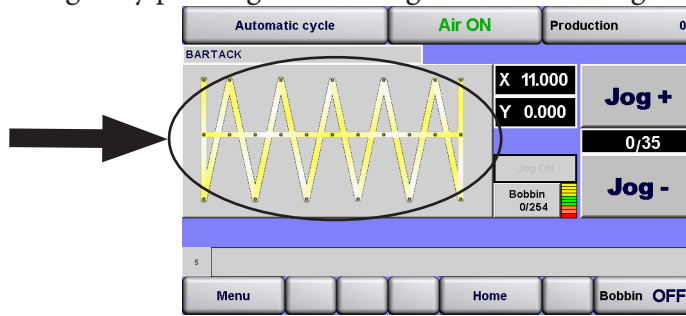

The following screen appears:

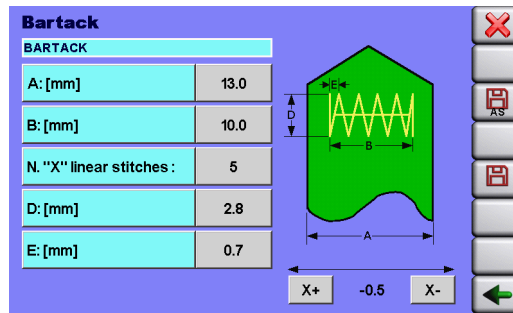

Enter the values specified in the image. Simply touch the field where the value is to be inserted and the following screen will appear with a keyboard. After having changed the value, remember to confirm it by pressing ENTER.

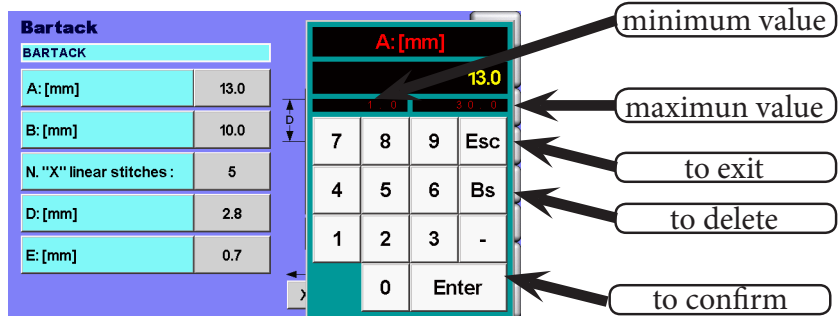

After having applied the desired changes with the "ENTER" button, press SAVE or SAVE WITH NAME.

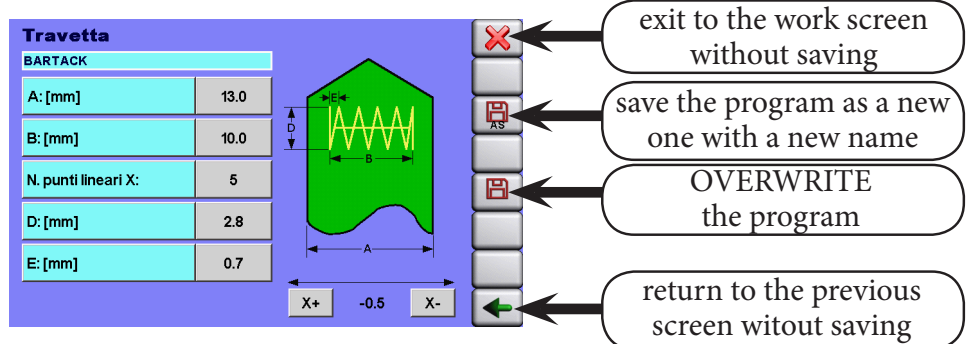

13. MENU

Pressing the MENU button the following screen will be shown

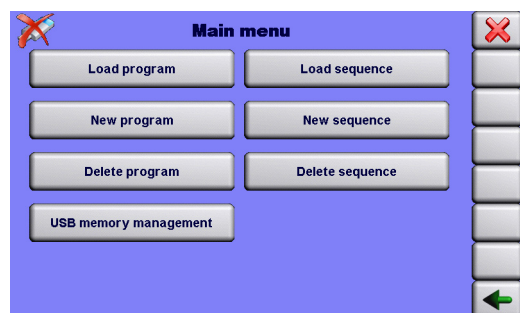
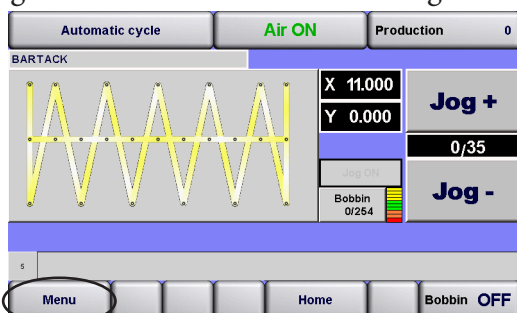

CAUTION!

- THE MENU BUTTON ONLY WORKS WHEN THE MACHINE IS IN STANDBY-BY POSITION
- FOR THE STAND-BY POSITION PRESS THE LEFT MULTI-FUNCTION

MICRO-SWITCH + THE  BUTTON

13.1- Loading a sewing program

From the main menu press the MENU icon and then LOAD PROGRAM

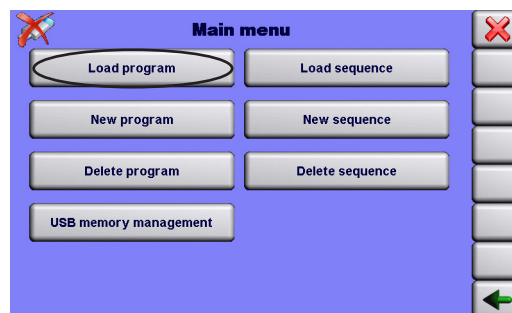
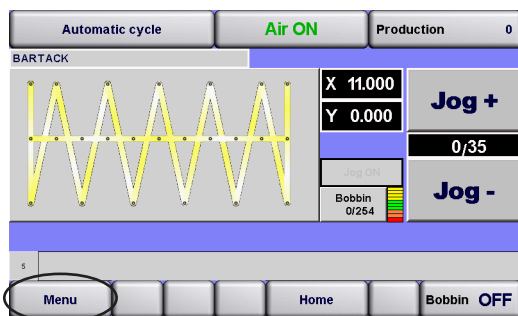

The following screen appears

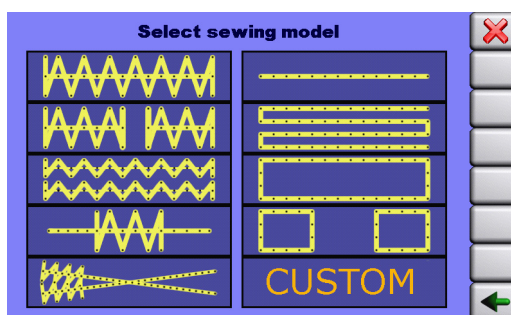

Select the desired program by pressing on it. This screen appears where a list with all programs from this category, saved in the machine memory will be shown.

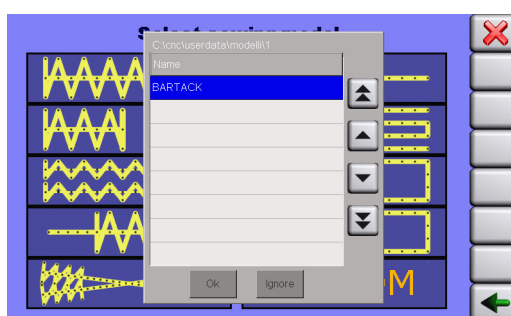

To select the desired program press on the name and to confirm press OK

13.2- Creating a new sewing program

From the main menu press the MENU icon and then NEW PROGRAM

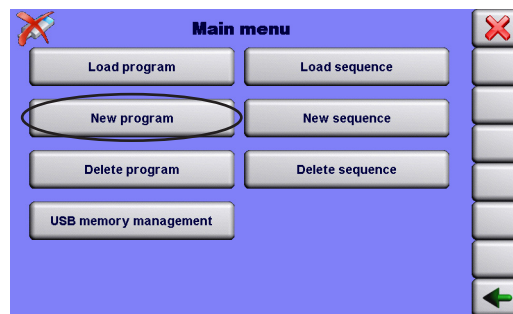
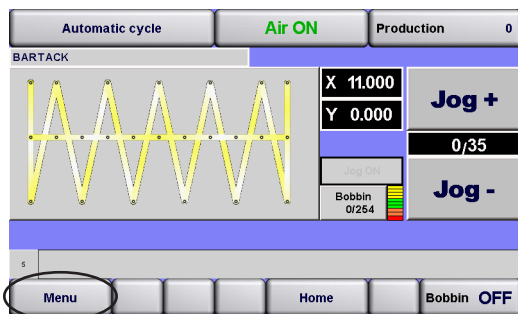

The following screen appears

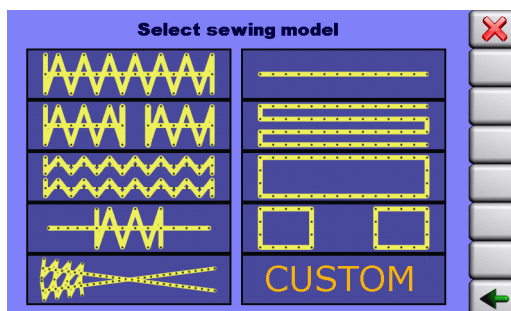

Select the desired program type from the 9 types displayed, the next screen will give the possibility to insert the necessary parameters

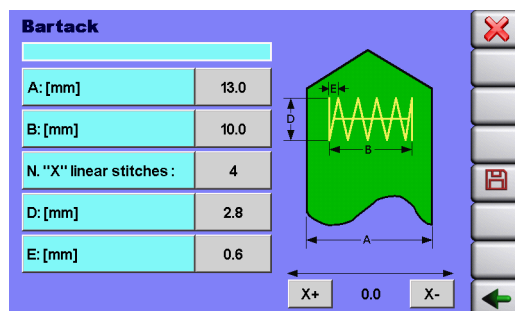

To insert the desired parameter press on the value on the left side of each letter, the following keyboard will be displayed:

Enter each measure to create the desired tacking stitch:

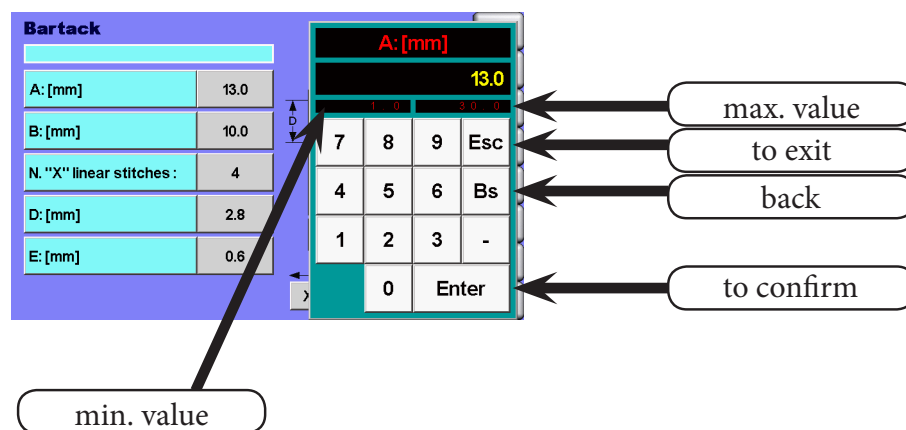

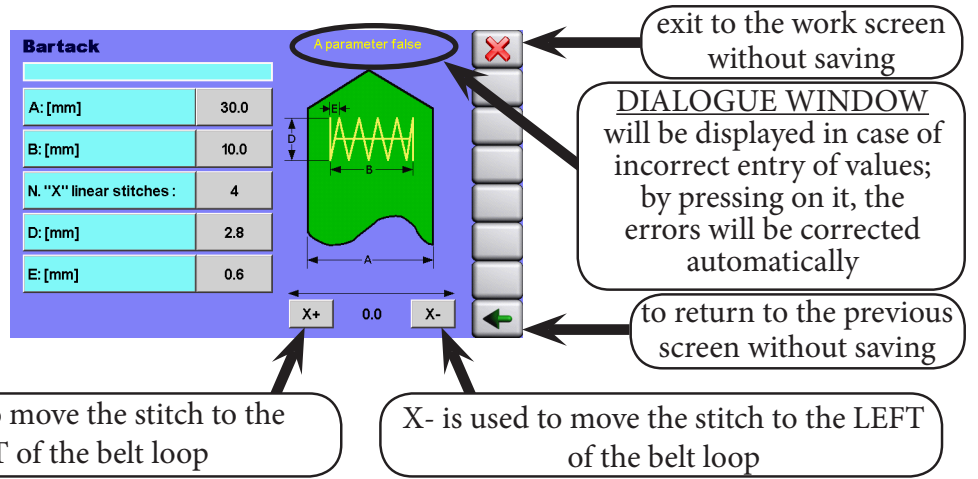

After having inserted all values, SAVE the program by selecting the desired icons

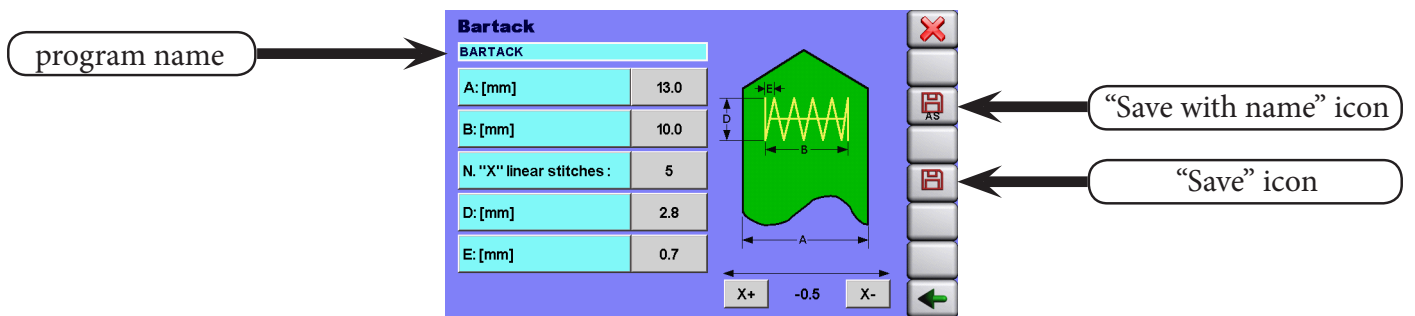

By pressing the "SAVE WITH NAME ICON" the following screen will appear where it is possible to assign the desired name to the sewing program

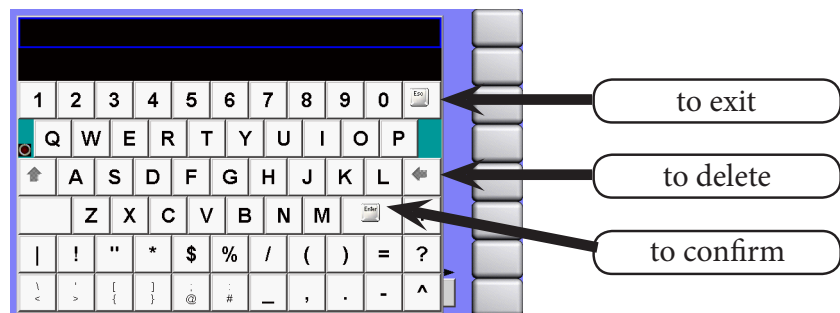

CAUTION!

Special characters such as `-?!"£$%&/()`. cannot be added to the name of the program to be saved

13.3- Deleting a sewing program

From the main menu press the MENU icon and then DELETE PROGRAM

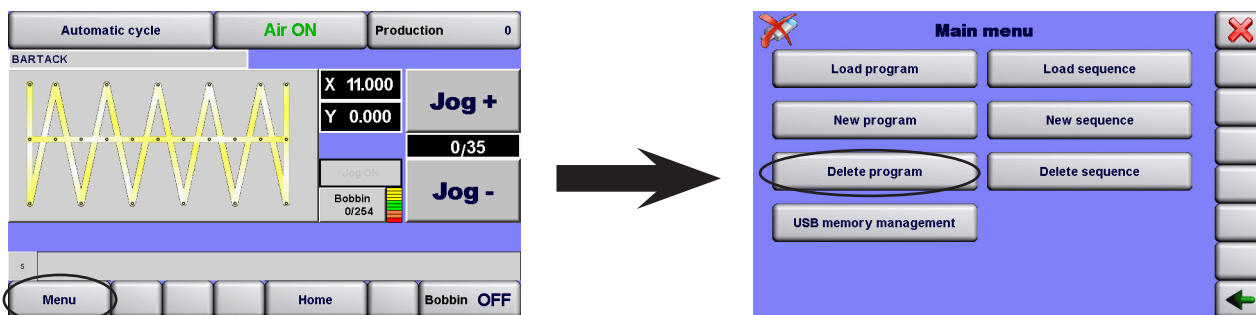

The following screen appears

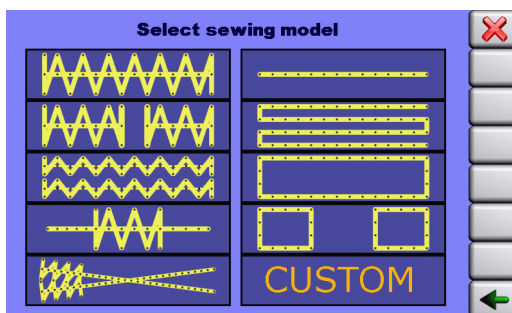

The following screen appears with the list of the saved programs available to be deleted. There are three icons:

- “MULTI” to highlight the names of the programs to be “DELETED”
- “DELETE” to delete the selected programs
- “ANNUL” to return to the main screen and annul the deletion of the selected programs

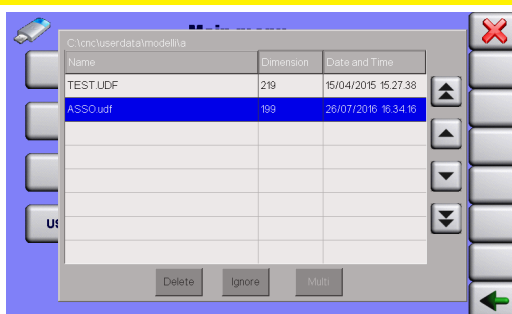

The following screen appears

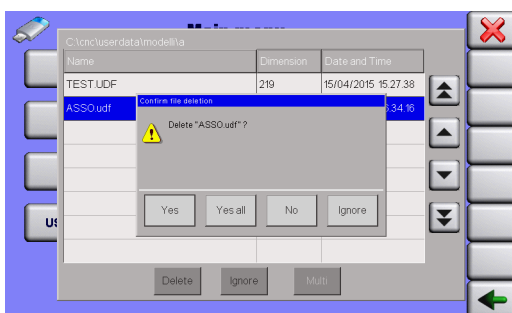

Press the “YES” or “YES ALL” icon to permanently delete the previously selected programs

Press the “NO” or “ANNUL” icon to return to the main screen and permanently cancel all operations in progress

 **CAUTION!**
THE PROGRAM IN USE CANNOT BE DELETED

13.4- USB memory management

On a formatted pen drive create 11 folders, and rename them as follows: 10 folders will have a progressive numbering that goes from number 1 to number 10, while one will have to be called with the letter “a” to be used for the sequences. (see figure below)

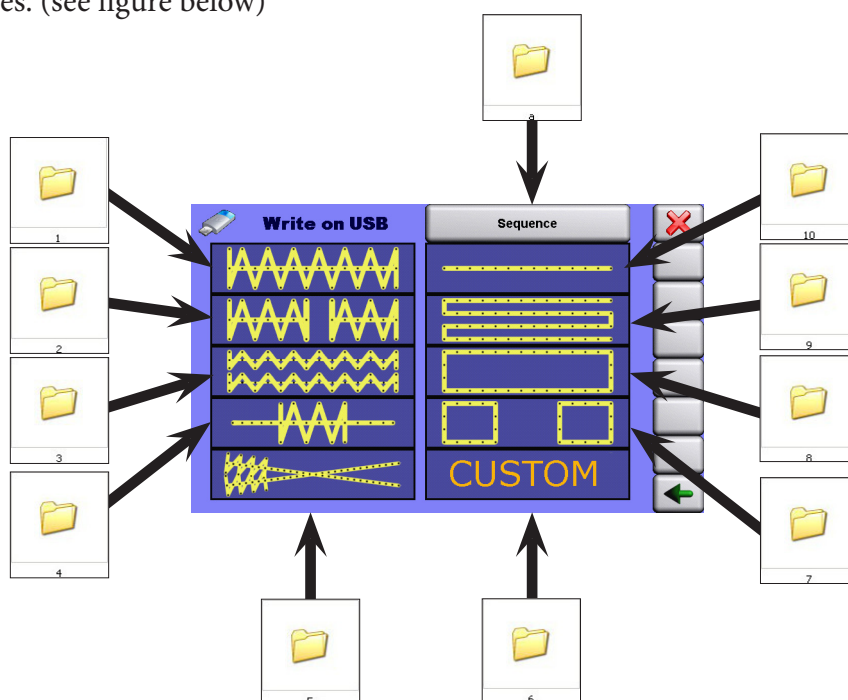

From the main menu press the MENU icon and then USB MEMORY MANAGEMENT

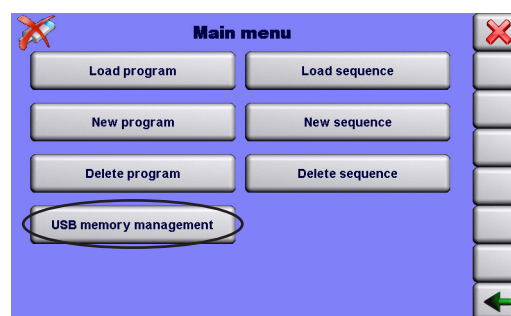
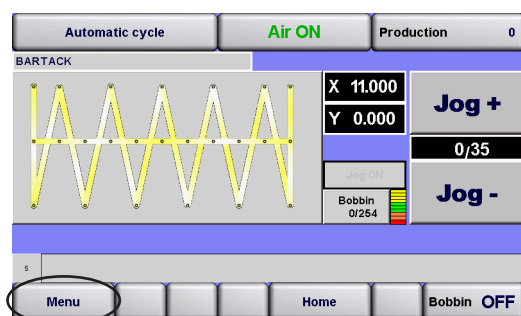

If the memory unit IS NOT DETECTED, the top left of the screen will display 

If the memory unit IS DETECTED, the top left of the screen will display 

Press USB MEMORY MANAGEMENT, and the screen appears where you can choose whether to WRITE or to READ

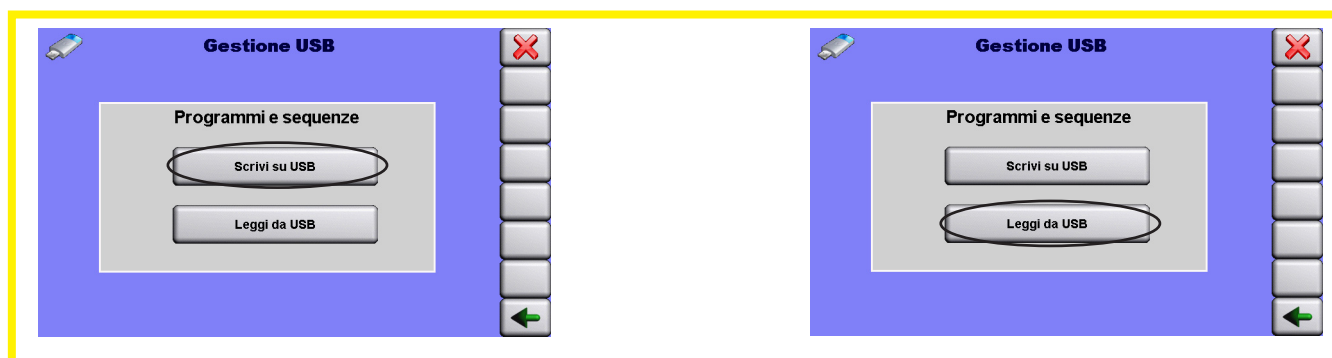

Then select the program or sequence to WRITE or to READ.

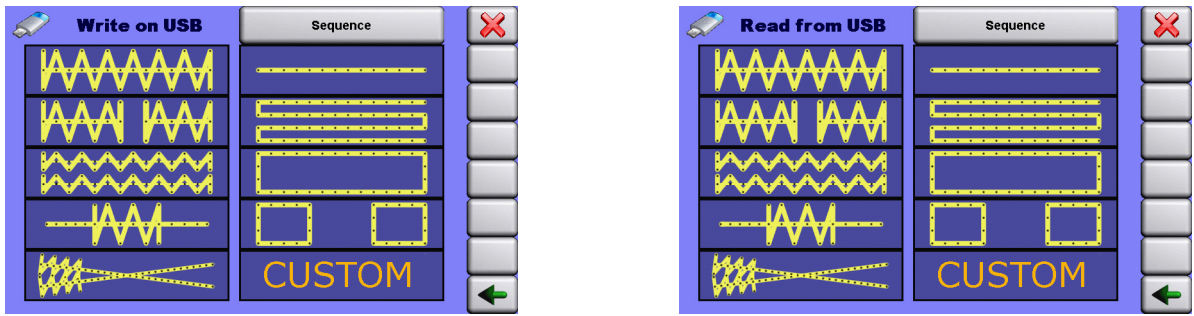

Select the program to be copied and press COPY

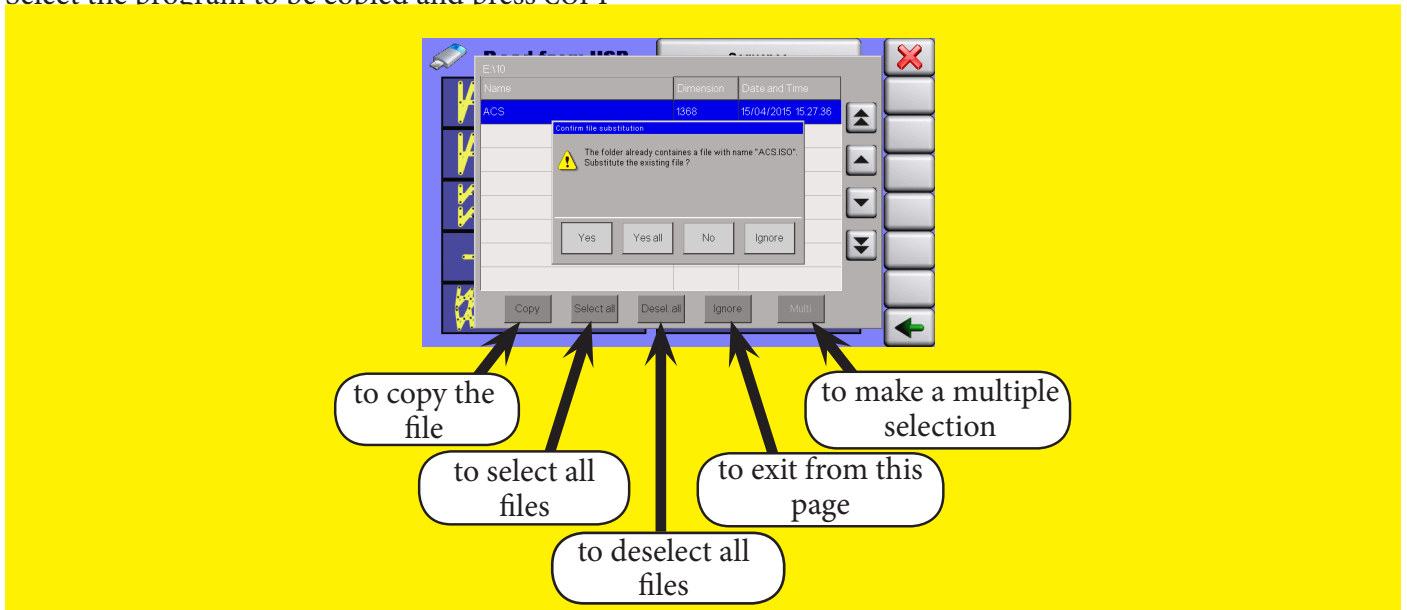

CAUTION!

IF THE PROGRAM IS ALREADY PRESENT IN THE USB EXTERNAL MEMORY OR IN THE INTERNAL MEMORY OF THE UNIT, THIS SCREEN WILL APPEAR AND ASK THE USER TO OVERWRITE

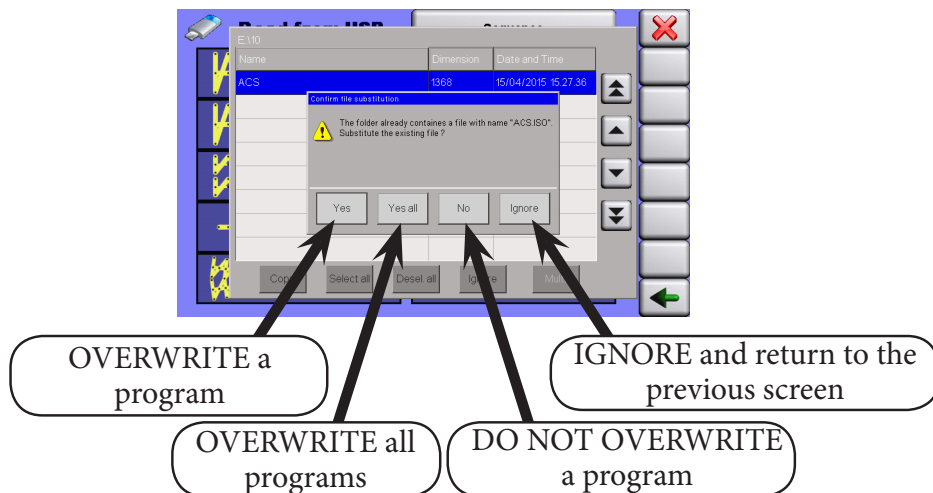

After WRITING or READING the desired program, press the “BACK ARROW” to return to the previous screen or “X” to return to the work screen.

13.5- Loading a sequence of sewing programs

From the main menu press the MENU icon and then LOAD SEQUENCE

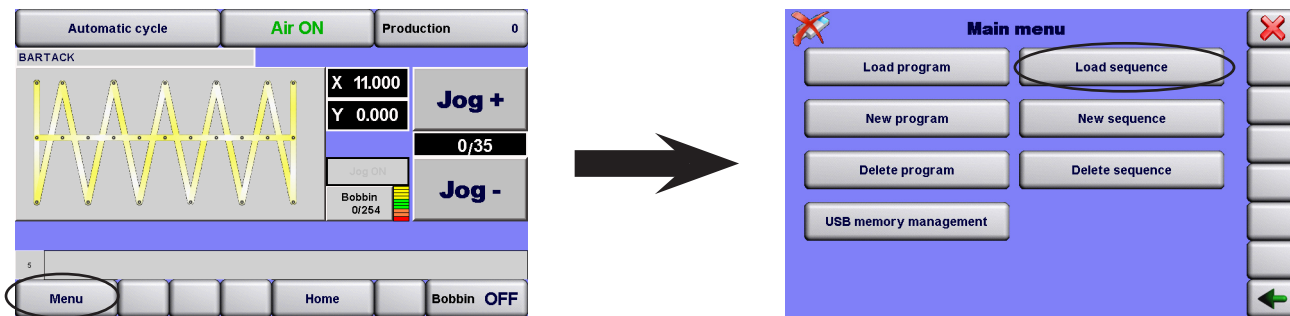

Select the desired sequence and press OK to confirm, or IGNORE to return to the main screen.

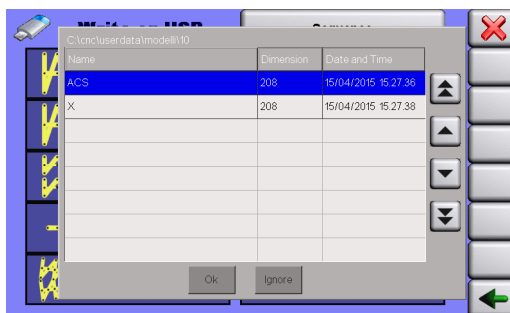

13.6- Create a new sequence of sewing programs

From the main menu press the MENU icon and then NEW SEQUENCE

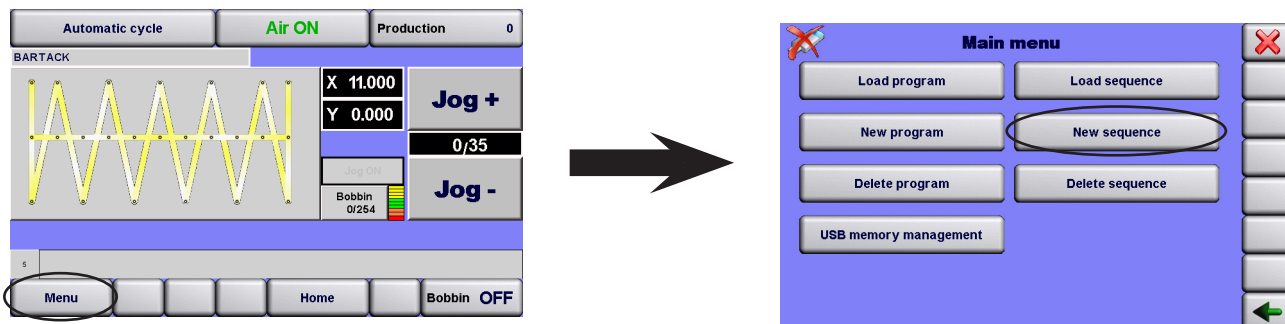

Press “NEW SEQUENCE” and the following screen will appear:

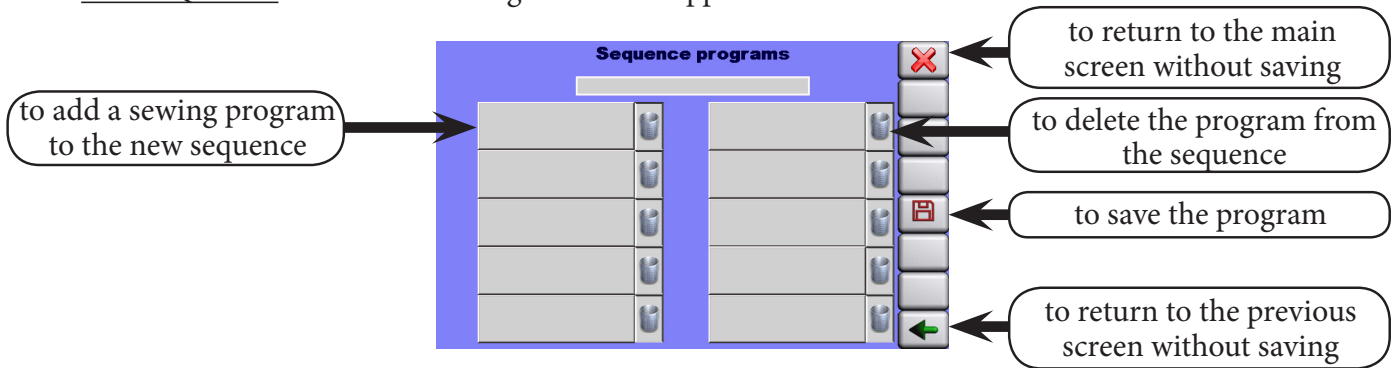

Then, the following screen appears. Select the type of program you want to add as the first program in the sequence, and confirm with “OK”

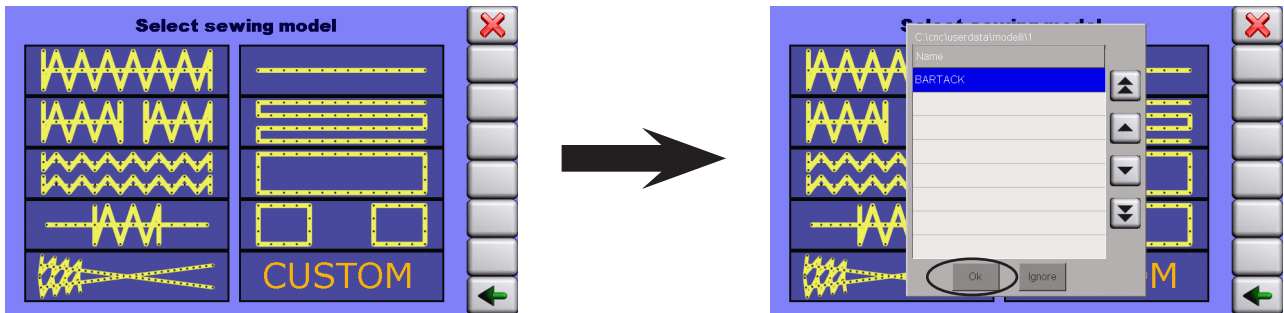

Select the desired program and press “OK” or press “IGNORE” to go back. Then, the following screen appears

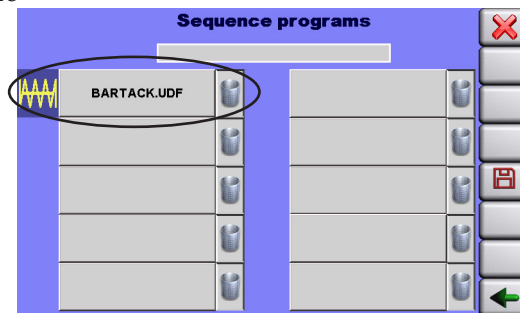

The program just selected is now in the first position; to add other programs to the sequence, repeat the previous operations by selecting the desired programs to load in second position, third position, etc.

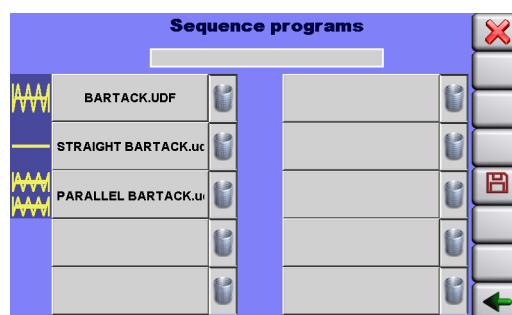

After adding all the desired programs in the sequence, press the “SAVE” button. Then, the following screen appears. Enter the desired name and confirm by pressing “ENTER”

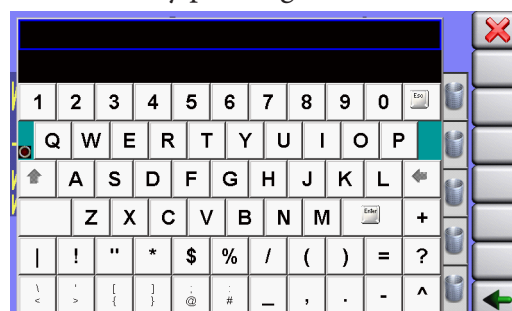

13.7- Delete a sequence

From the main menu press the MENU icon and then DELETE SEQUENCE

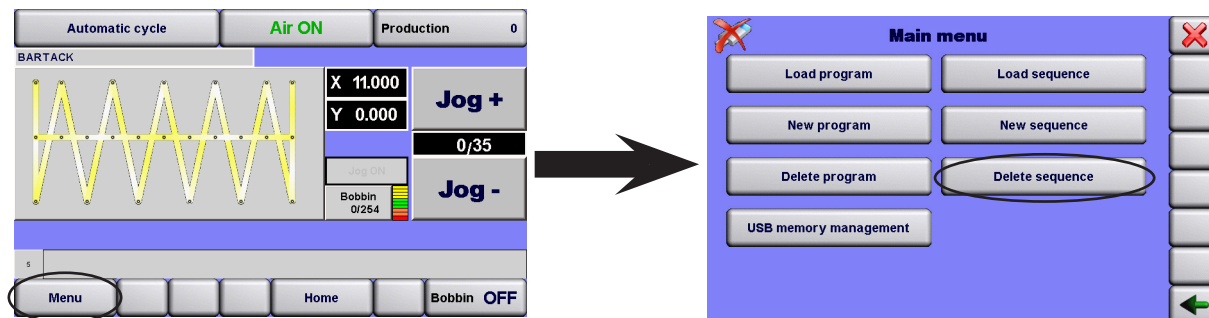

Select the desired sequence; if you need to select more than one sequence, press MULTI

Once the desired sequence have been selected, press DELETE

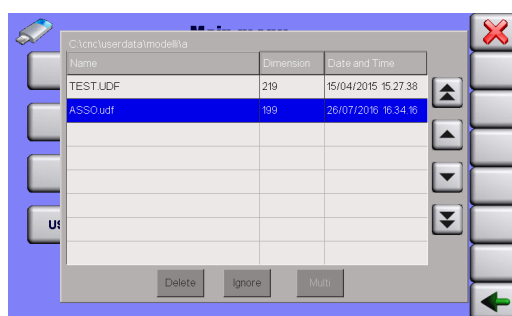

This screen will appear:

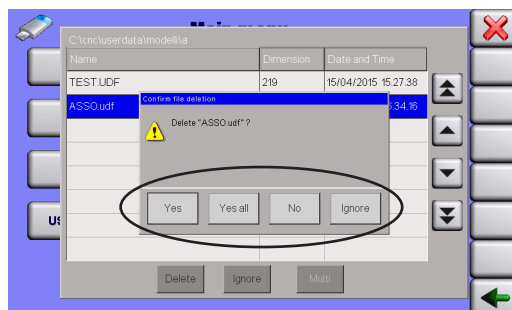

Press YES or YES ALL to delete the sequence, or NO if you do not want to delete.
Press IGNORE to return to the main screen.

14. PARAMETERS

14.1- Machine parameters

The LS 4/9 panel mounted on the unit is equipped with a protection key for technical use. The menu changes by turning the protection key, and 3 new icons appear: PARAMETERS, ALARM LIST AND TEST

CAUTION!

THE KEY IS ONLY FOR TECHNICAL USE TO BE USED BY THE AUTHORISED PERSONNEL

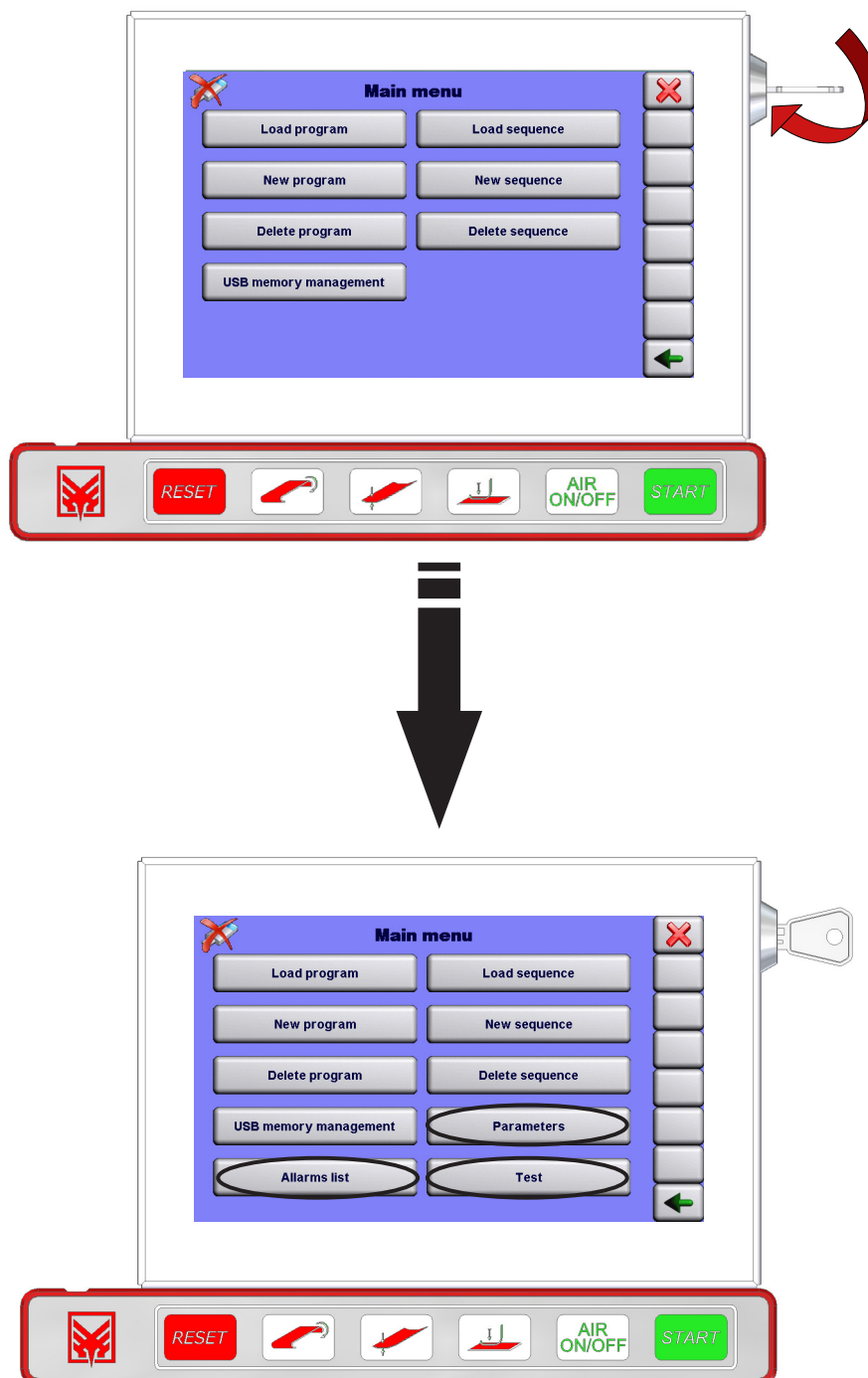

14.1.1- Sewing area

From the main menu press the MENU icon and then press PARAMETERS (N.B. the key must be turned).

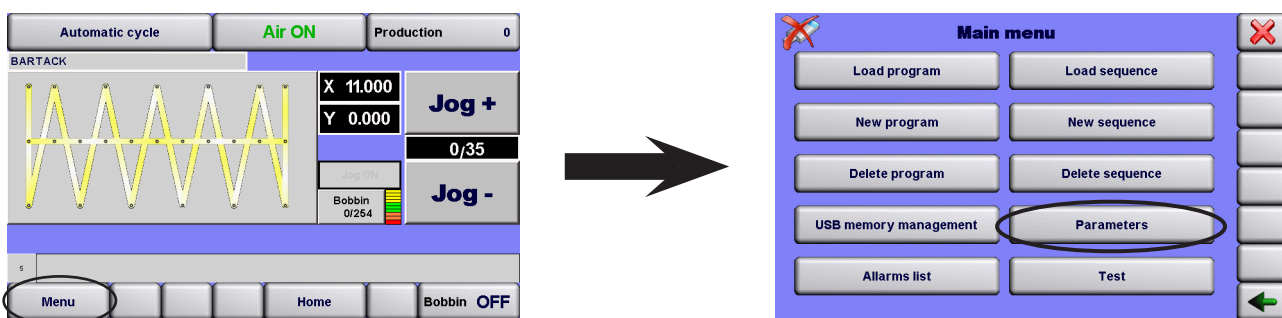

The following screen appears. Press sewing area to increase or decrease the value of the X and Y axis in the case of custom stitching.

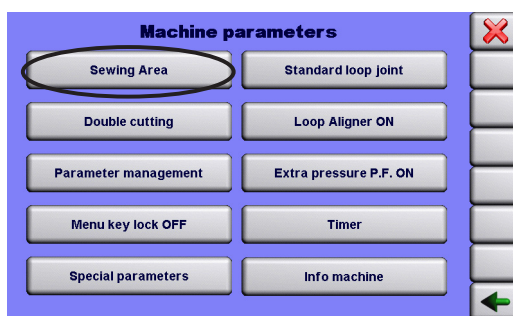

Pressing this icon it will display the following screen where values can be entered for the desired sewing area.
 Standard value X 24.0 and Y 5.0
 Maximum value X 28.0 and Y 15.0

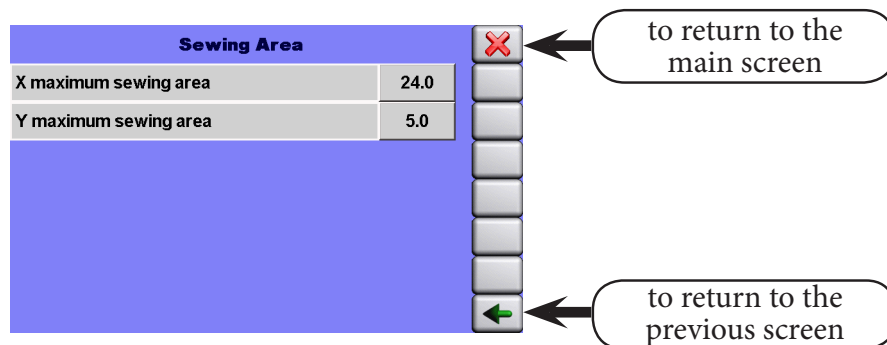

CAUTION!
 IF THE VALUE INCREASES, CHECK WITH JOG IF THE SEWING PROGRAM IS COMPATIBLE WITH THE PRESSER FEET INSTALLED AND THE FEEDING PLATE , ETC.

14.1.2- Double/single loop cut

From the main menu press the MENU icon and then press PARAMETERS (N.B. the key must be turned).

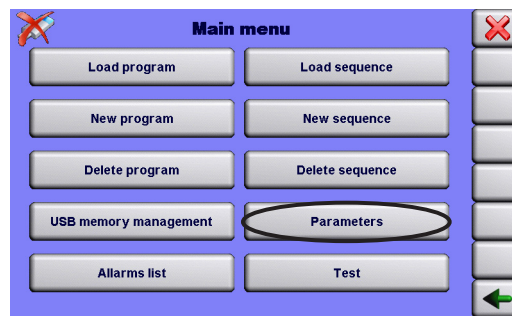
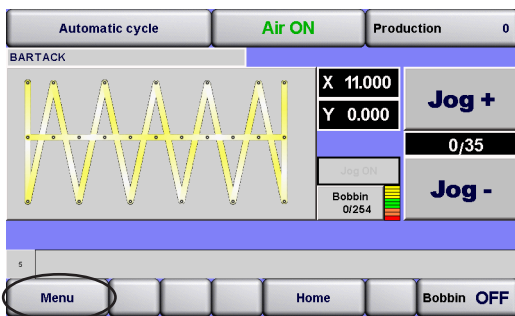

In the screen that appears, if you press the DOUBLE CUT item, the wording will change to SINGLE CUT and vice-versa. When selecting the DOUBLE CUT option, during the preparation of the loop cycle, the unit will make two cuts to have a loop cut at an angle (see image below)

When selecting the SINGLE CUT option, during the preparation of the loop cycle, the unit will make a loop with a straight cut, see image below.

DOUBLE CUT

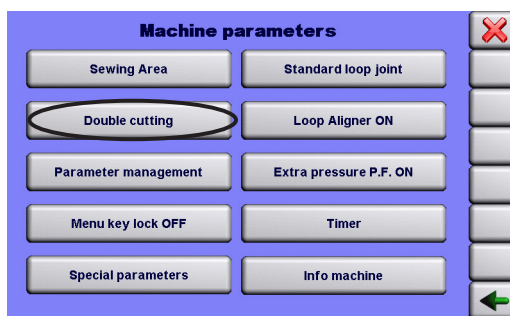
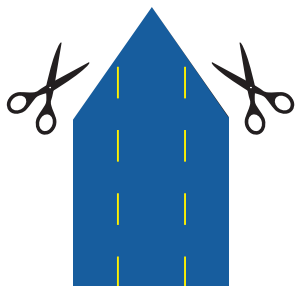

SINGLE CUT

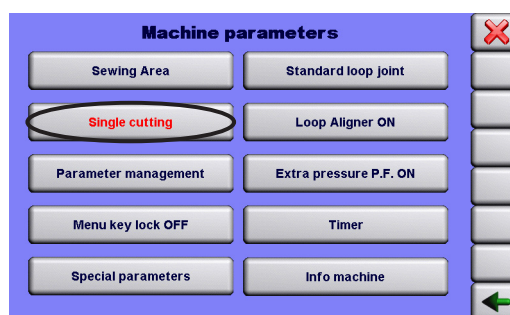
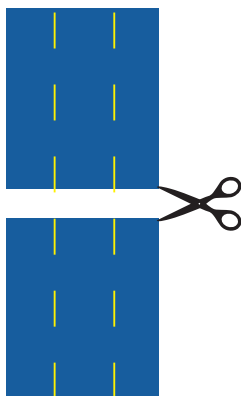

CAUTION!

FOR A SINGLE CUT, THE POSITION OF THE LOOP CUTTING BLADE MUST BE ADJUSTED MECHANICALLY

14.1.3- Parameters management

From the main menu press the MENU icon and then press PARAMETERS (N.B. the key must be turned).

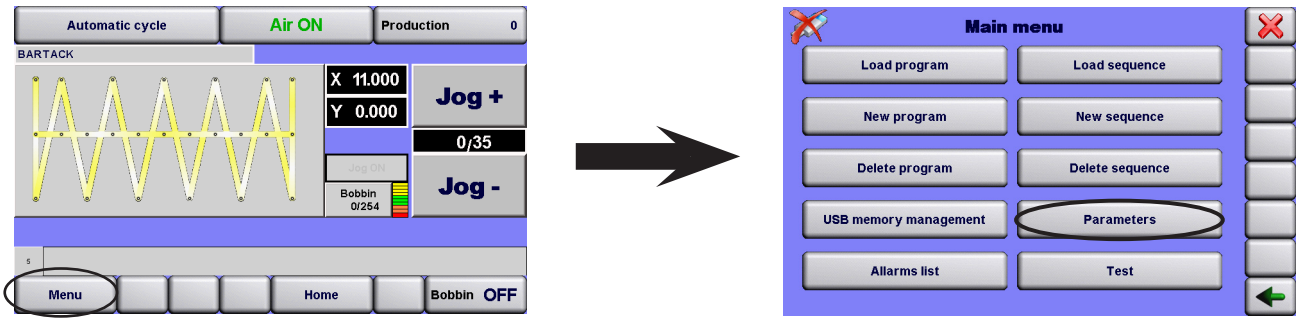

On the screen that appears, press PARAMETERS MANAGEMENT

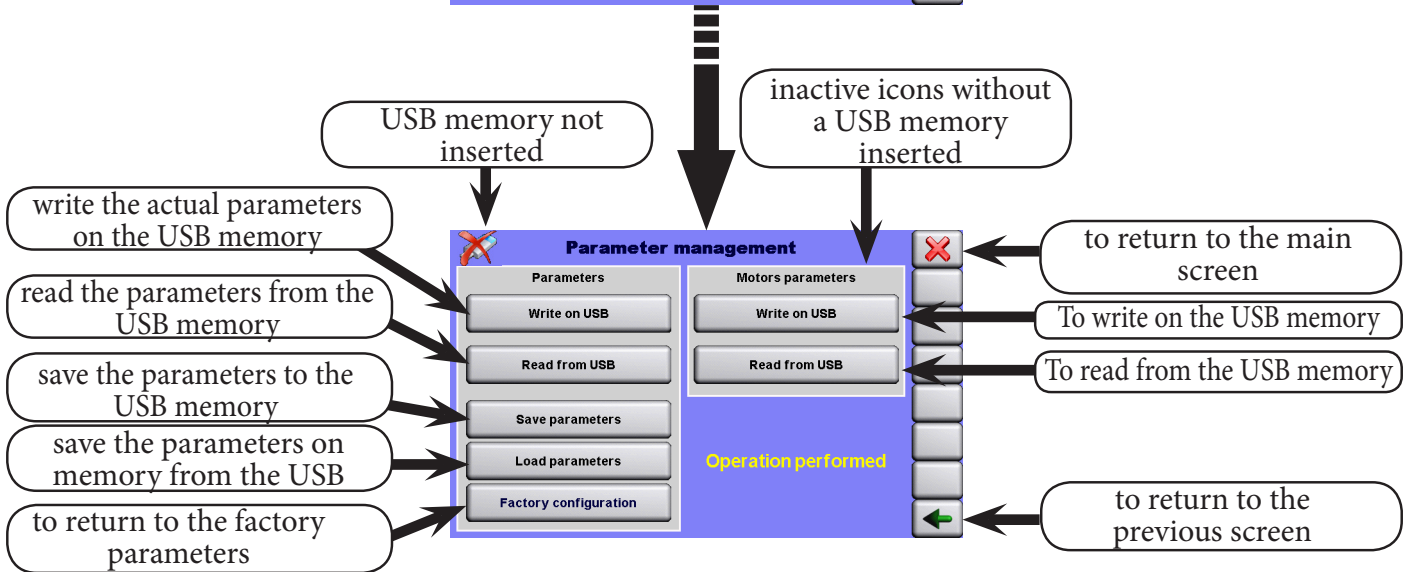
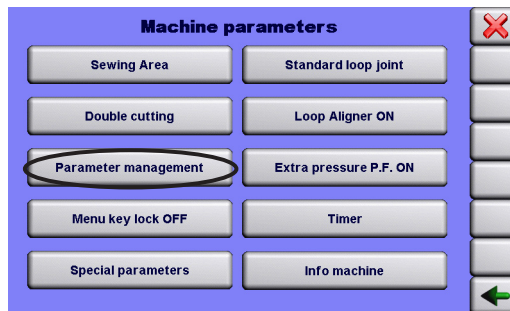

14.1.4- Lock OFF menu button

From the main menu press the MENU icon and then press PARAMETERS (N.B. the key must be turned).

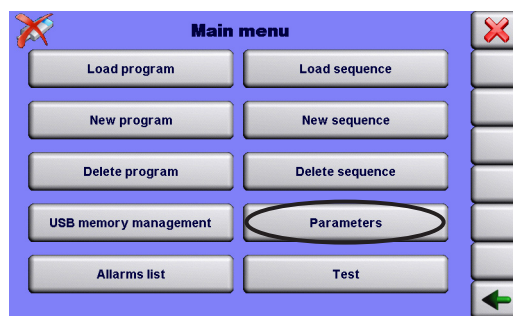
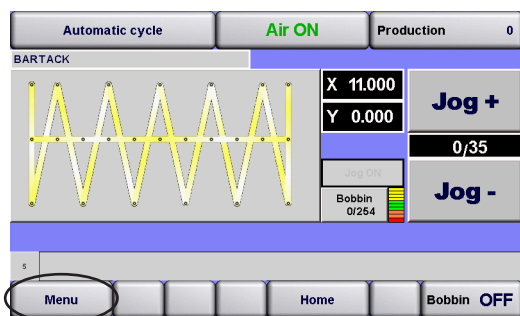

The following screen appears. Pressing the MENU KEY LOCK OFF icon, it will become MENU KEY LOCK ON

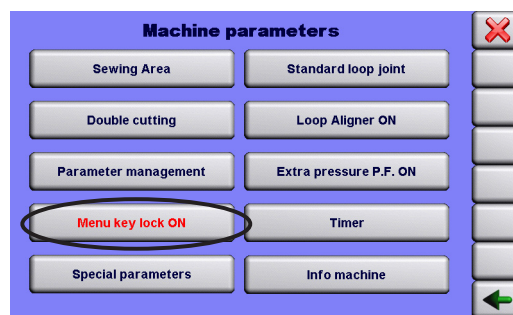
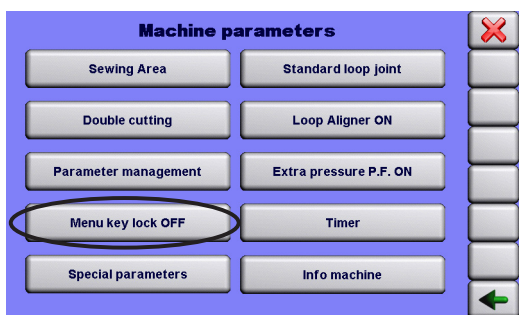

This option blocks access to the menu, the MENU button only works with the key turned, the operator cannot even load/create/delete sewing programs, **only the technicians can use this function.**

14.2- Special parameters

From the main menu press the MENU icon and then press PARAMETERS (N.B. the key must be turned).

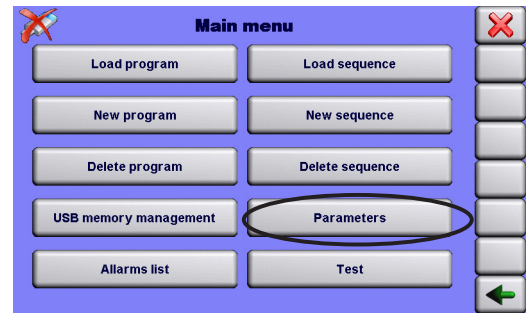
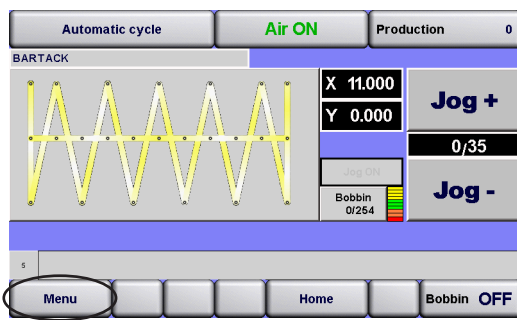

The following screen appears. Press SPECIAL PARAMETERS

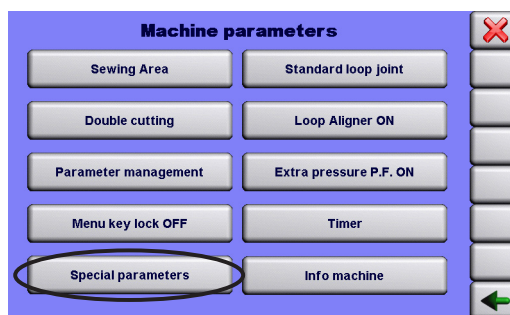

to return to the main screen

to return to the previous screen

You are asked to enter a password

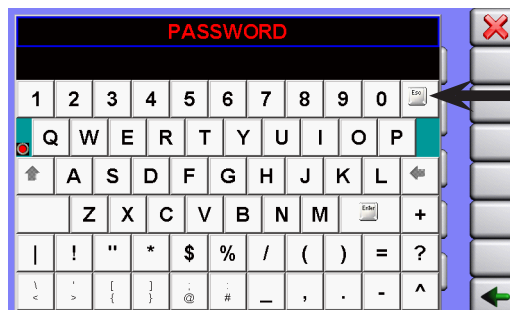

to exit from the password entry screen

CAUTION!
THIS FUNCTION IS ONLY USED BY THE VI.BE.MAC SENIOR TECHNICIANS

14.3- Loop joint

From the main menu press the MENU icon and then press PARAMETERS (N.B. the key must be turned).

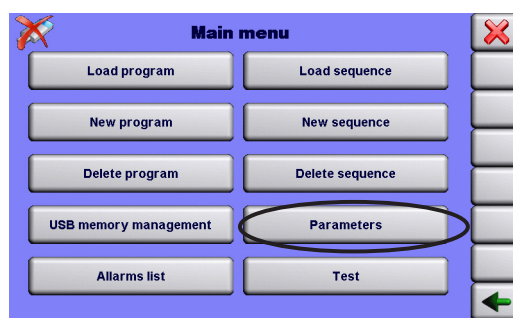
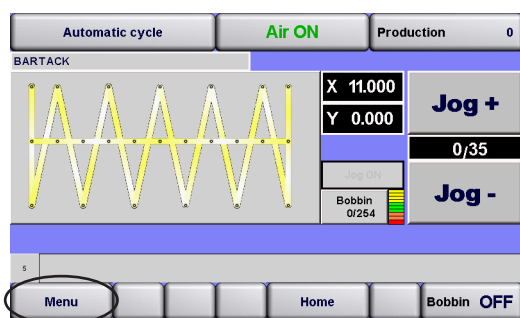

The following screen appears. Pressing the STANDARD LOOP JOINT icon, the wording will change to INVERTED LOOP JOINT.

The STANDARD LOOP JOINT it is the joint of a loop that has a bigger thickness than the loop, see image below.

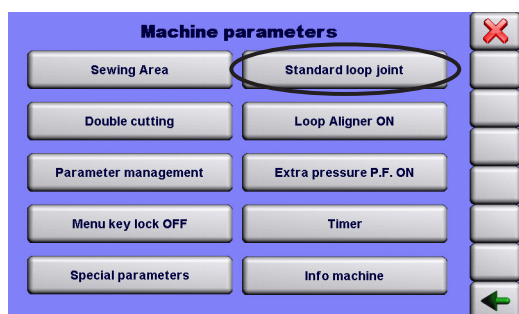

Use with STANDARD LOOP JOINT



When the function is changed to INVERTED LOOP JOINT, during the loading cycle, the unit will only select the joint with a lower thickness than the loop, see image below.

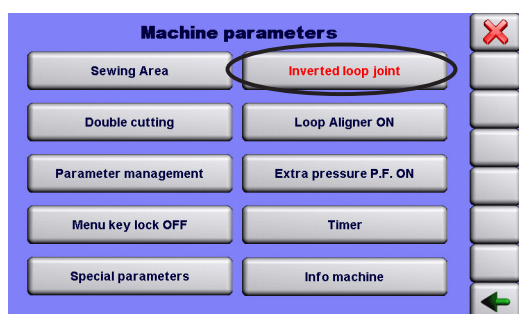

Use when the loop joint has a lower thickness than the loop

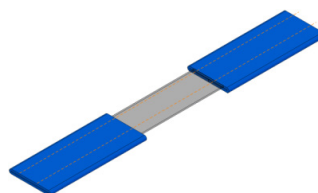

14.4- Straightener enabling and disabling

From the main menu press the MENU icon and then press PARAMETERS (N.B. the key must be turned).

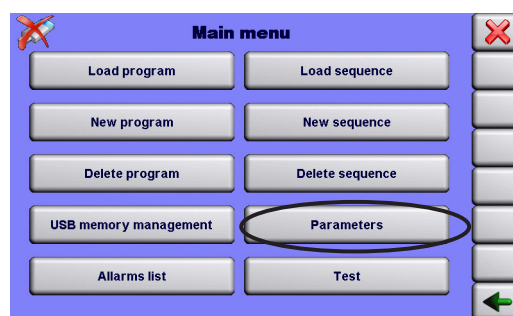
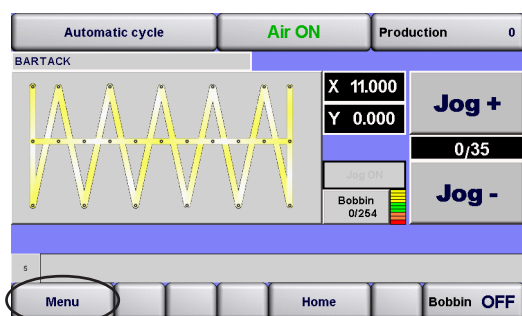

The following screen appears. Pressing the LOOP ALIGNER ON icon, the function will change to LOOP ALIGNER OFF. The LOOP ALIGNER ON is the standard operating mode when, during the loop preparation cycle, the aligner works to correct the position of the loop and to keep the quality of the loop constant before sewing.

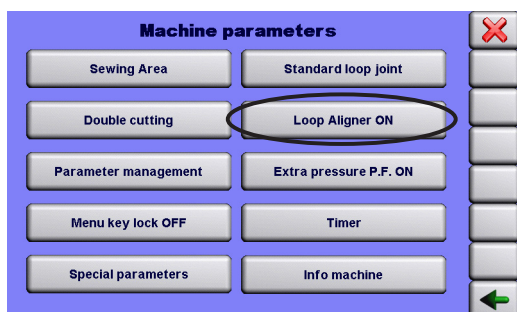

LOOP ALIGNER ON

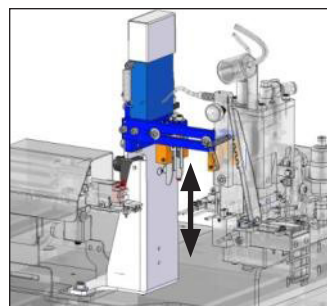

When the option is changed to LOOP ALIGNER OFF the loop preparation cycle will work normally but without the aligner functioning, for ex. in case of the inserted loop option.

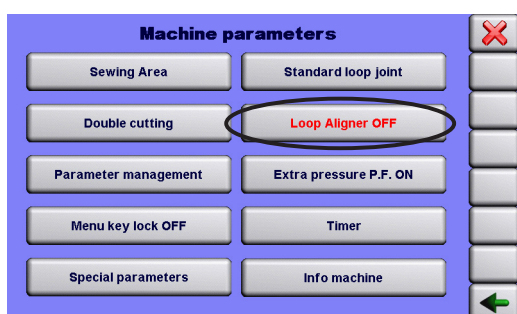

STRAIGHTENER
DISABLED

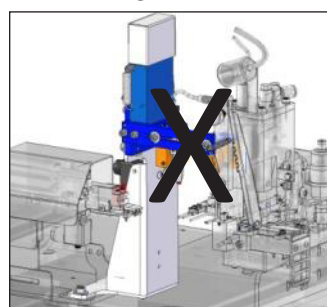



14.5- Extra pressure on Presser Foot

From the main menu press the MENU icon and then press PARAMETERS (N.B. the key must be turned).

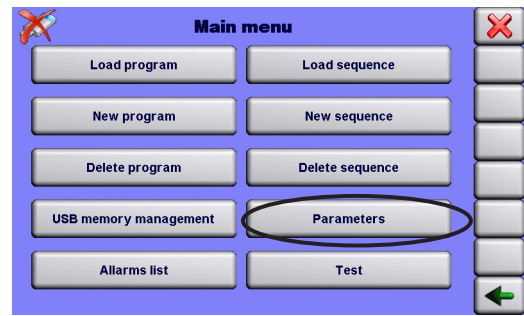
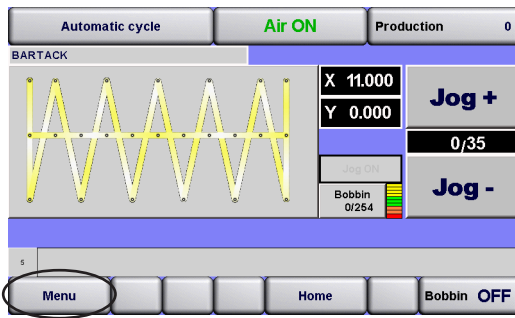

The following screen appears, where we can enable or disable this function simply by pressing the icon as shown in the following images.

When the unit works with the function 'EXTRA PRESSURE P.F. ON' enabled, the presser foot are lowered to fix the loop with more pressure than that used during the sewing, this option is used for heavy fabrics.

When the unit works with the function 'EXTRA PRESSURE P.F. OFF' enabled, the presser foots are lowered to fix the loop with the same pressure as that used during the sewing, this option is used for light fabrics.

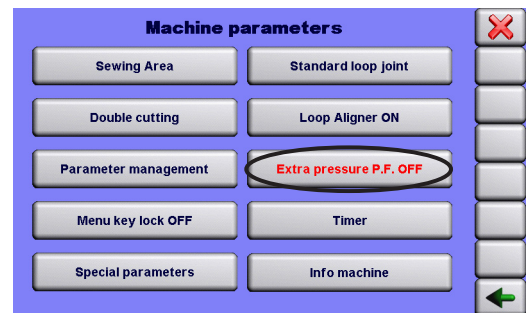
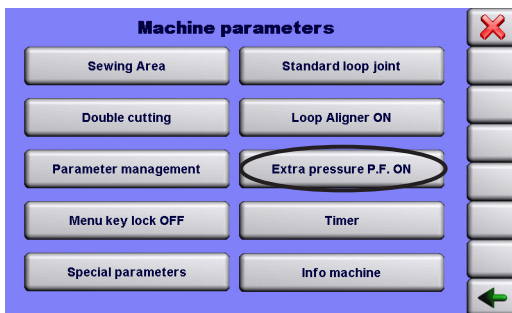

14.6- Timer list

From the main menu press the MENU icon and then press PARAMETERS (N.B. the key must be turned).

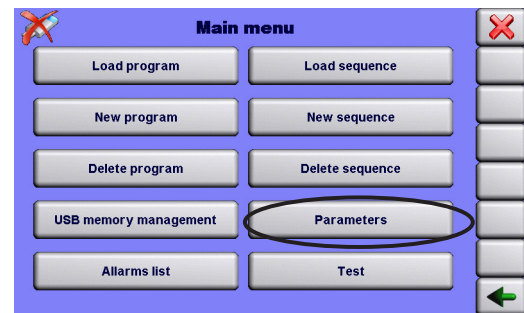
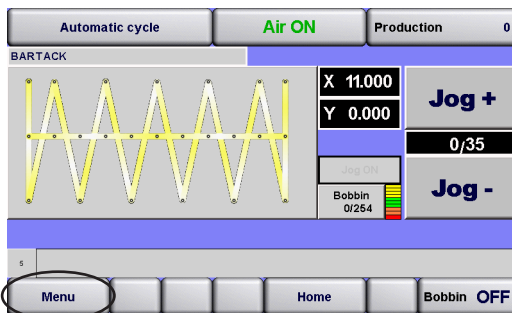

The following screen appears:

Press **TIMER** and then the screen with the first page of the timer list appears, there are 4 pages available that can be scrolled, all containing the timers with the relative description. The value set by the producer have the best speed-quality ratio, the timer value is adjustable to adapt the unit for use on particular fabrics.

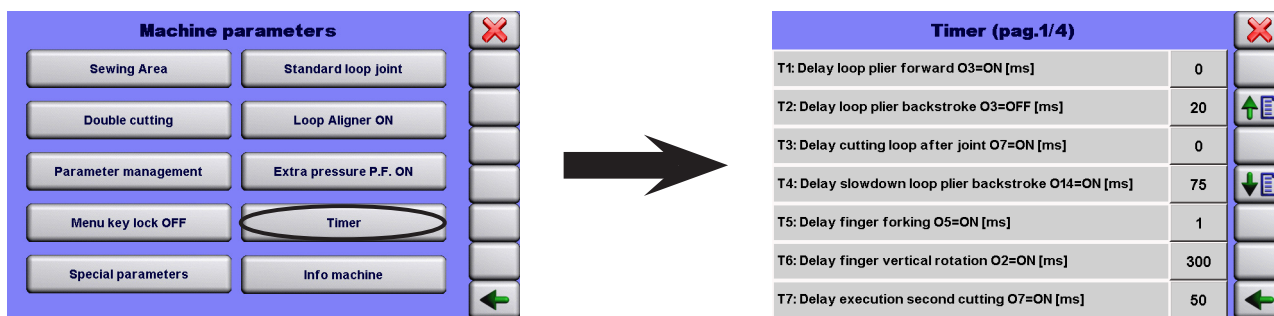

When we select a timer to be adjusted, a numeric keypad will appear, there are shown the minimum and maximum values of that timer, and allows to enter a desired value. At the end of the entry press “ENTER” to confirm the value entered or press “ESC” to exit without saving the changes.

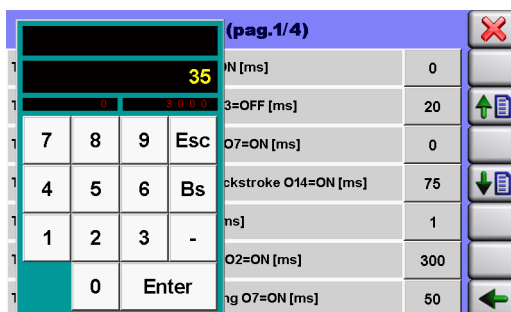

To go to the next screen of the timer list press

To go to the previous screen of the timer list press

To return to the previous screen press

To return to the main screen press

4650EV9@UP2 TIMER LIST

T1	Delay of the loop pull forward calliper O3 = ON (ms)	0
T2	Delay of the loop pull back calliper O3 = OFF (ms)	20
T3	Delay of the loop after the seam cutting O7=ON (ms)	0
T4	Delay of the loop pull back calliper deceleration O14 = OFF (ms)	60
T5	Delay of the loop forking O5=ON (ms)	1
T6	Delay of the vertical clamping device rotation O2=ON (ms)	200
T7	Delay of the second cutting O7=ON (ms)	30
T8	Delay of the horizontal clamping device rotation O2=OFF (ms)	30
T9	Delay of the intermediate stop O10=ON (ms)	155
T10	Delay of the feet lowering O9=ON (ms)	5
T11	Sewing start delay (ms)	0
T12	Free	100
T13	Duration of the loop release power cylinder pulse O18 (ms)	150
T14	Delay of the loop cutting rotation O17 (ms)	50



T15	Delay of the lower clamping carriage O15=OFF (ms)	5
T16	Delay of the loop pull calliper closure O13 = ON (ms)	20
T17	Free	0
T18	Delay of the lower clamping carriage O1=OFF (ms)	40
T19	Delay in raising of the feet at the end of sewing O9 = OFF (ms)	240
T20	Delay of the clamp calliper activation O6 = ON (ms)	20
T21	Delay in activation of the straightener O11 = ON (ms)	0
T22	Delay in deactivation of the straightener O11 = OFF (ms)	150
T23	Delay in suction activation O20 = ON (ms)	0
T24	Delay in suction deactivation O20 = OFF (ms)	200
T25	Deactivation of the clamp calliper O6 = OFF (ms)	0
T26	Extra pressure delay OFF after I9 O16 = OFF (ms)	100
T27	Free	100
T28	Delay O4 =OFF after O13=OFF (ms)	20

14.7- Info machine

From the main menu press the MENU icon and then press PARAMETERS (N.B. the key must be turned).

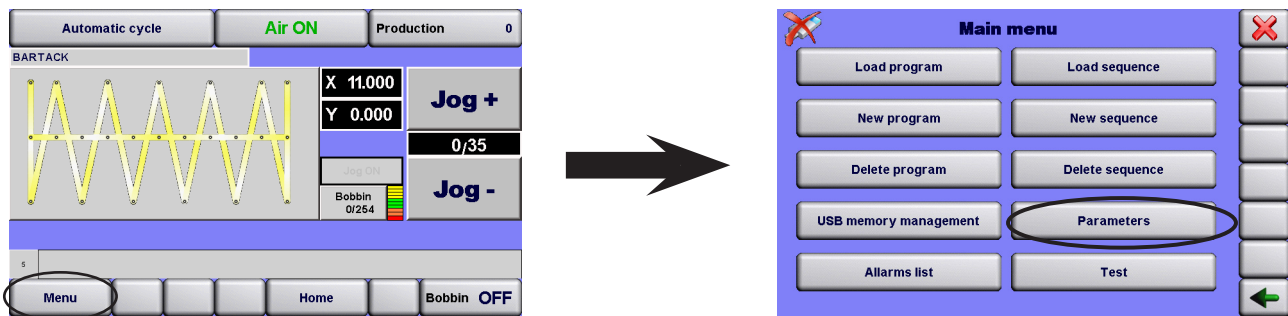

The following screen appears. Press INFO MACHINE, and then the summary screen appears with information on the installation date, number of sewing cycles followed by the unit and the installed software version.

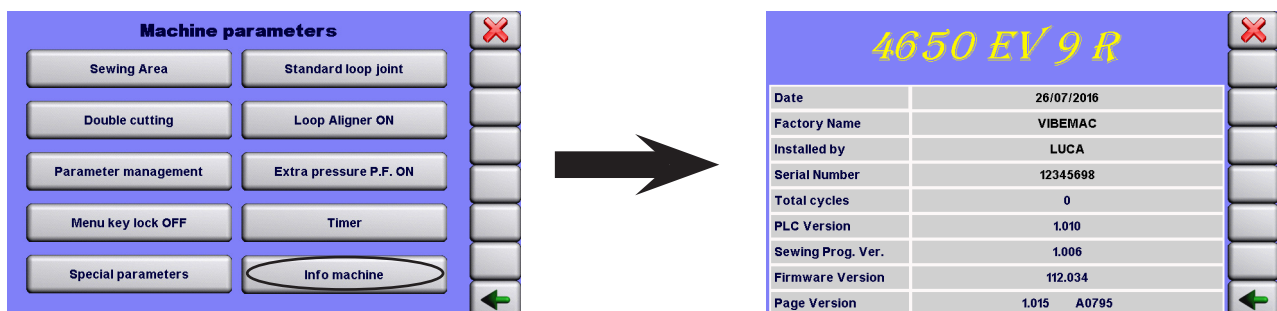

To return to the previous screen press

To return to the main screen press

15. ALARM LIST



From the main menu press the MENU icon and then press ALARM LIST (N.B. the key must be turned).

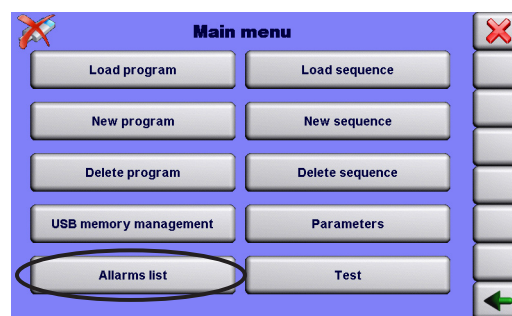
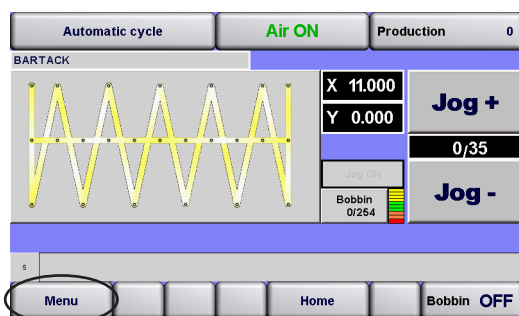

The following screen will be displayed where there are available for check the list of errors that happened on the unit with the date and time, plus the description of the error. This way the technician can understand the problems found and improve the performance of the unit.

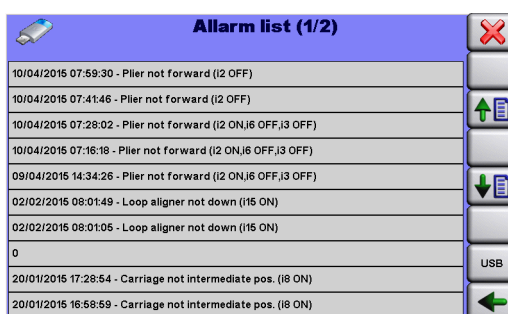

To go to the next page of the alarm log list press 

To go to the previous page of the alarm log list press 

Press  to create a .txt file on the USB device called Log in order to easily share the unit information or send it by e-mail, if needed.

16. TEST

From the main menu press the MENU icon and then press TEST (N.B. the key must be turned).

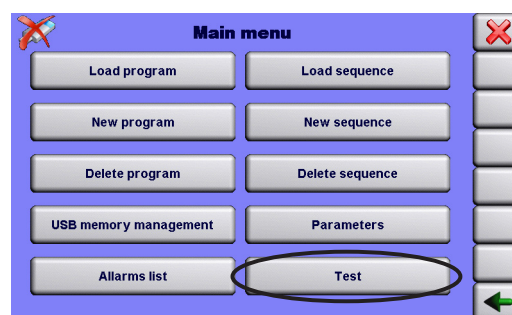
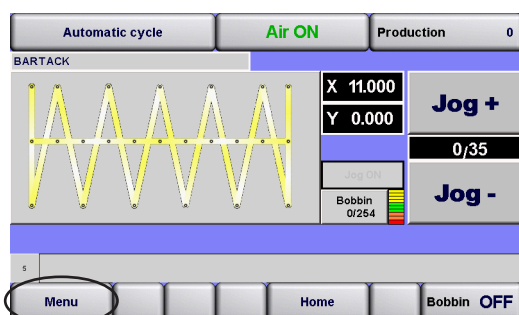

The following screen appears.

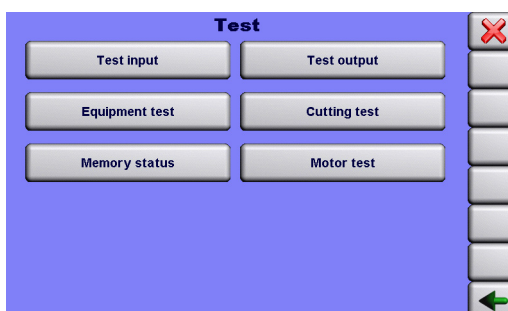

16.1- Test Input

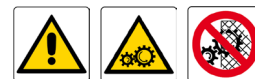

From the TEST screen, select the TEST INPUT icon

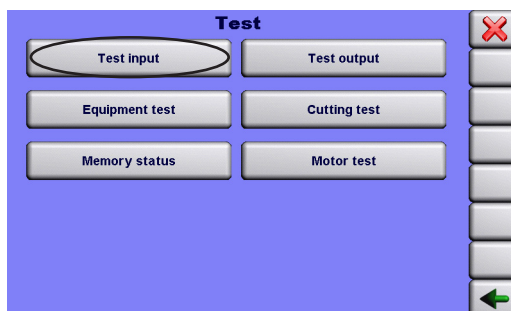

The following screen appears:

Press TEST INPUT and then the screen with the first page of the input list will appear, there are 5 pages available that can be scrolled, all containing the inputs with the relative description.

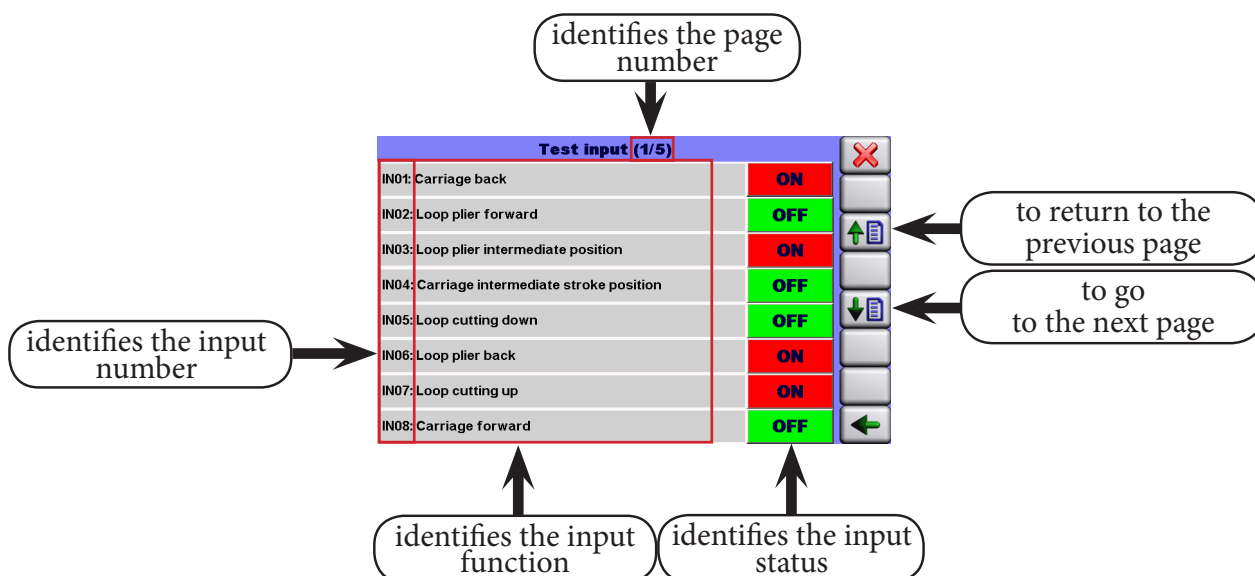

CAUTION!

TO TEST THE INPUTS:

- deactivate the air
- move the equipment by hand
- the 2 multi-purpose micro-switches can be tested by pressing them

If you return to the previous screen, by pressing the arrow key, the following screen is displayed which shows the message “Press Home + Left Micro Switch” to ensure that all the parts of the unit are in the correct position.

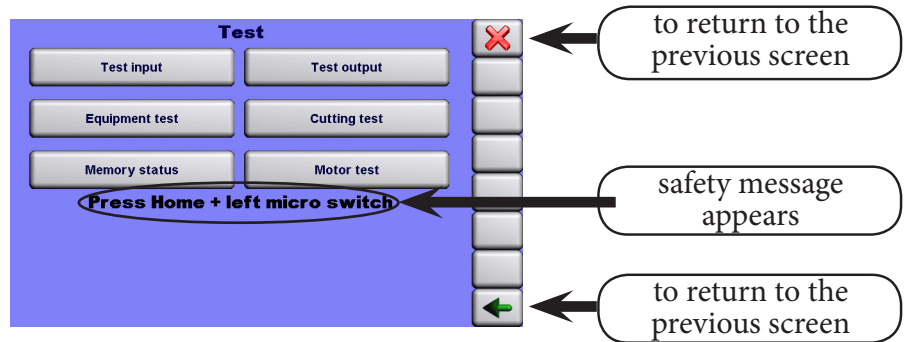

Press X to return to the main screen

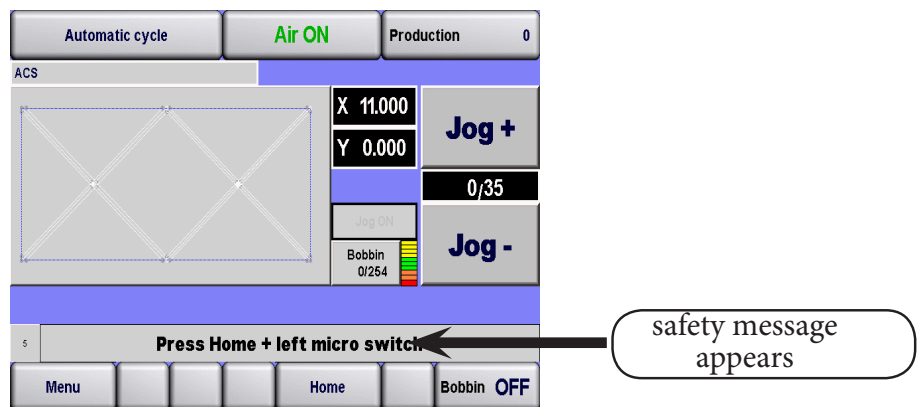

To return to work mode, press the HOME button and the LEFT MULTI-FUNCTION button.

16.1.1- Inputs

All inputs present have a dual function:

- They transmit to the logic circuit the signal that the ordered mechanical action has been performed
- They check if it is possible to perform the next mechanical action

To check the work of the individual detectors, the following test must be performed checking their position in the following diagram:

Start the machine following the correct procedure, then remove the air by pressing the AIR OFF button on the panel

Call up the INPUT TESTS (MICRO-BUTTON, SENSORS OR AIR PRESSURE SWITCHES) on the panel. Gently touch the sensor head with a metal object (for example, a screwdriver) to see if the logical position changes from OFF to ON, or press on the micro-button.

N.B. The distance between the sensor and the detector must be between 0.2 and 0.5 mm.

INPUT No.	SENSOR TYPE	FUNCTION
IN01	N.O.	Loop loader back
IN02	N.O.	Loop pulling cylinder forward
IN03	N.O.	Loop pulling cylinder intermediate position
IN04	N.O.	Loop loader intermediate position
IN05	N.O.	Loop cutting cylinder down
IN06	N.O.	Loop pulling cylinder back
IN07	N.O.	Loop cutting cylinder up
IN08	N.O.	Loop loader forward
IN09	N.O.	Presser foot down
IN10	N.O.	Loop joint
IN11	N.C	Head position safety
IN12	N.C	Thread trimmer back
IN13	N.O.	Left micro-switch
IN14	N.O.	Right micro-switch
IN15	N.O.	Loop aligner up position
IN16	N.O.	Not connected
IN17	N.O.	Not connected
IN18	N.O.	Not connected
IN19	N.O.	Not connected
IN20	N.O.	Not connected
IN21	N.O.	Not connected
IN22	N.O.	Not connected
IN23	N.O.	Not connected
IN24	N.O.	Not connected
	N.O.	X axis sensor
	N.O.	Y axis sensor
	N.O.	Needle up position sensor

EXTERNAL BUTTONS		
		RESET BUTTON
		BELT LOOP LOADING BUTTON
		BELT LOOP CUTTING BUTTON
		PRESSER FOOT BUTTON
		AIR ON/OFF BUTTON
		START BUTTON

Key:

N.O.= sensor normally ON N.C.= sensor normally OFF

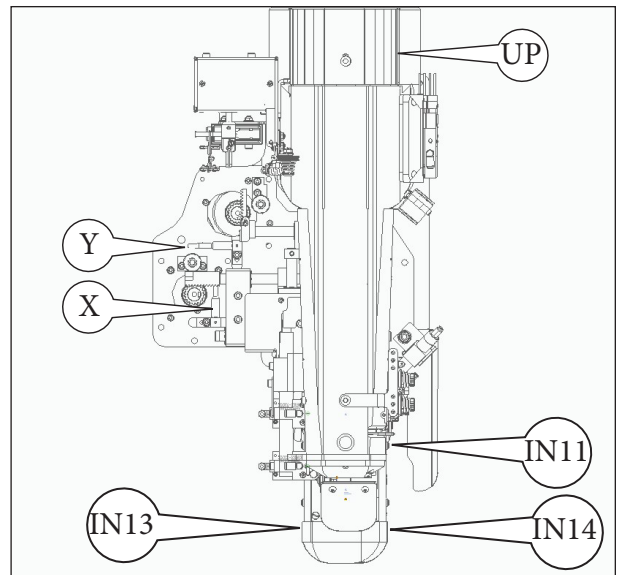
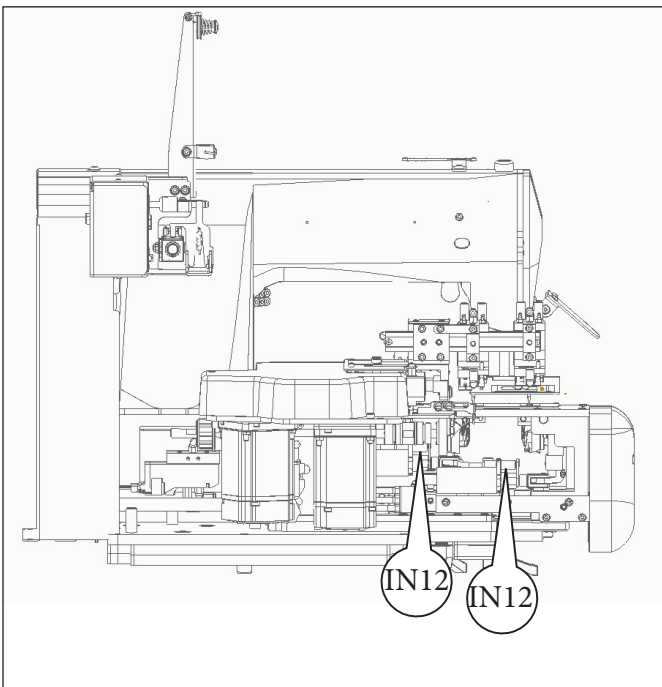
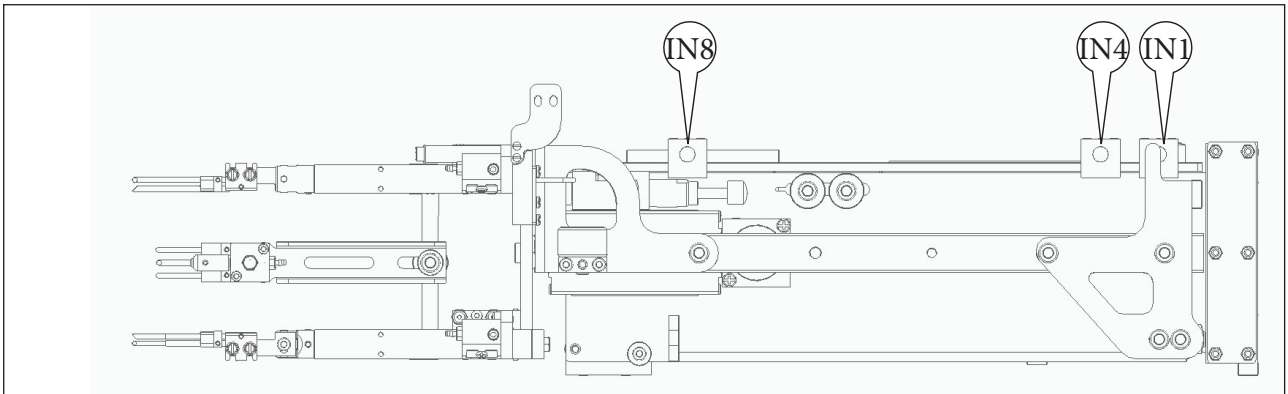
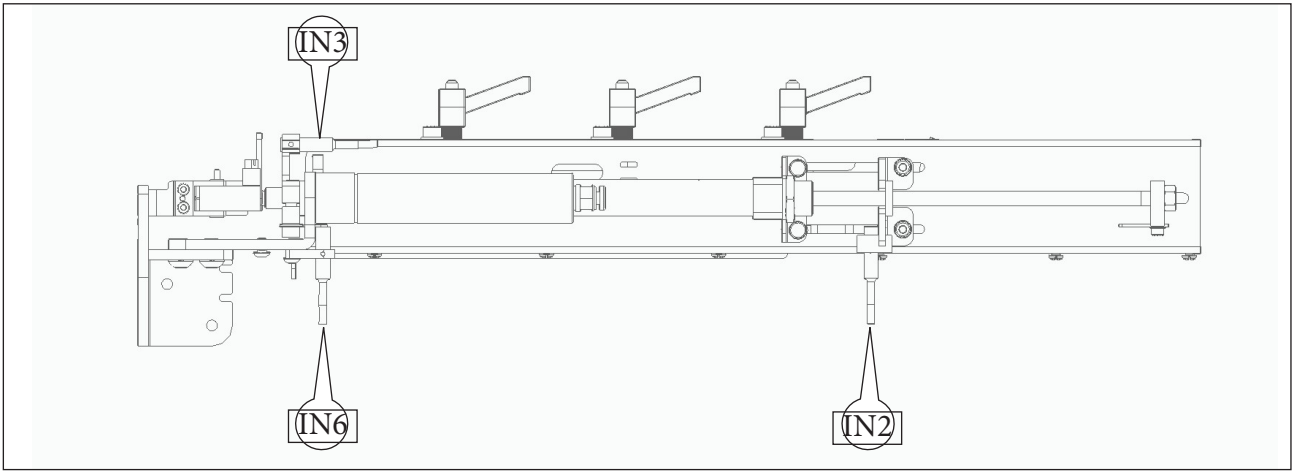

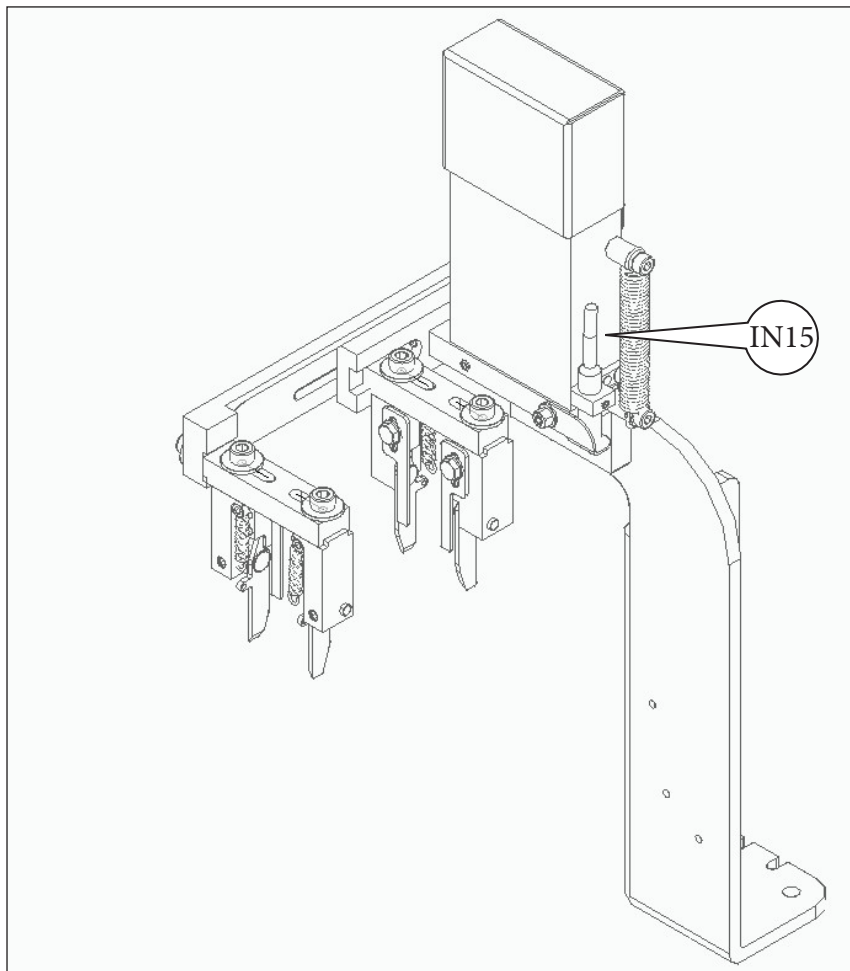
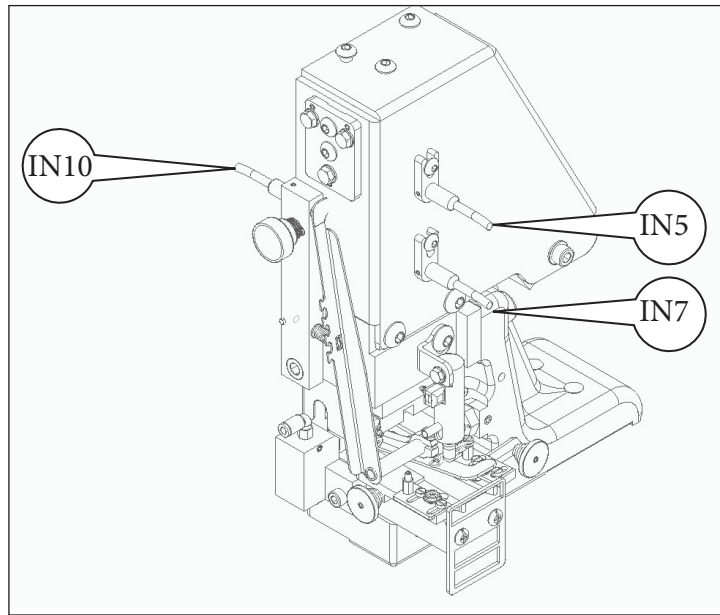

16.2- Output tests



From the main menu press the MENU icon and then press TEST (N.B. the key must be turned).

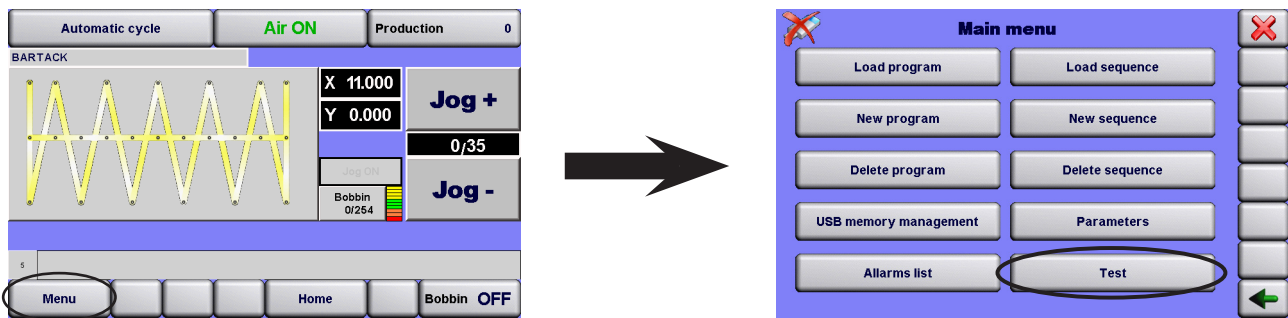

The following screen appears, press tests outputs

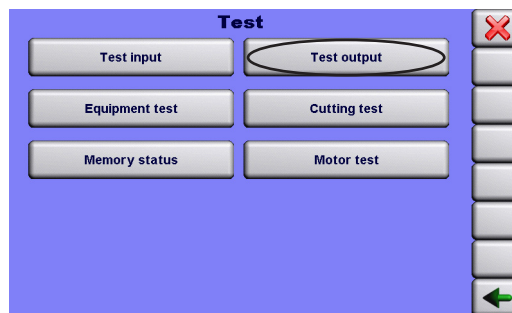

The following screen appears:

Press TEST OUTPUT and then the screen with the first page of the output list will appear, there are 3 pages available that can be scrolled, all containing the outputs with the relative description.

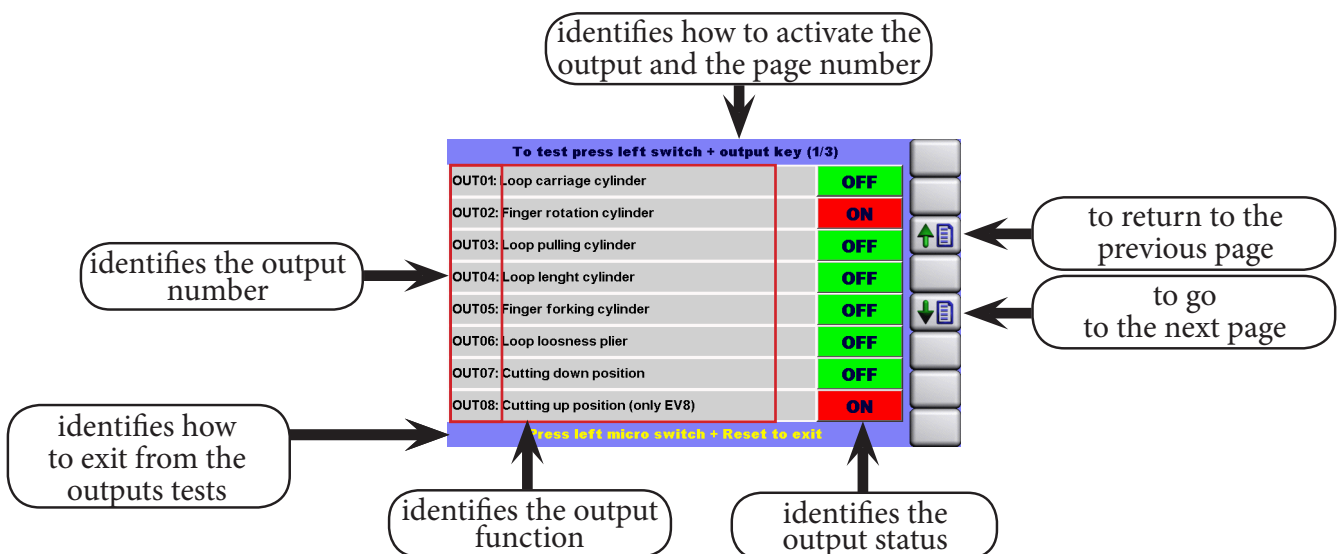

CAUTION!

For safety reasons the outputs will be activated only with the described procedure; before testing an output, the previous output must be returned to its original position

16.2.1- Outputs

Various types of solenoid valves are used on the 4650EV9@UP2 unit:

- 4-way solenoid valve, model N3E0660, used for the outputs: 8-18, 20-6, 16-9, 21-13, 14-4, 15-11, 19-22 and 5-1, which are located on the valve assembly
- 3-way solenoid valve, model N4E010, used for the outputs: 17, 2, 3 and 10, which are located on the valve assembly
- 5/2 port solenoid valve, model 4GA210R06GE22J3 used for output 7
- 5/2 port solenoid valve, model 4GD110RM5E21J3 used for outputs 30 and 31
- EV9K4ARIA-UP2 general air assembly used for general air supply (output 12)

OUTPUT NUMBER	FUNCTION
OUT 1	Loop loading forward cylinder
OUT 2	Fingers rotation cylinder
OUT 3	Loop pulling cylinder
OUT 4	Loop length cylinder
OUT 5	Loop finger forking cylinder
OUT 6	Loop loosness plier
OUT 7	Loop cutting
OUT 8	Loop stop for cutting
OUT 9	Presser foots cylinder
OUT 10	Loop loading back cylinder
OUT 11	Loop aligner cylinder
OUT 12	Main air supply
OUT 13	Loop pulling plier ON
OUT 14	Back loop pulling cylinder high speed
OUT 15	Loop loading carriage UP
OUT 16	Extra pressure on the presser foots
OUT 17	Loop cutting rotation
OUT 18	Loop tension release cylinder
OUT 19	Slowing loop loading carriage
OUT 20	Loop cutting suction
OUT 21	Loop pulling plier cleaning
OUT 22	Needle blowing
OUT 30	mitsubishi
OUT 31	mitsubishi

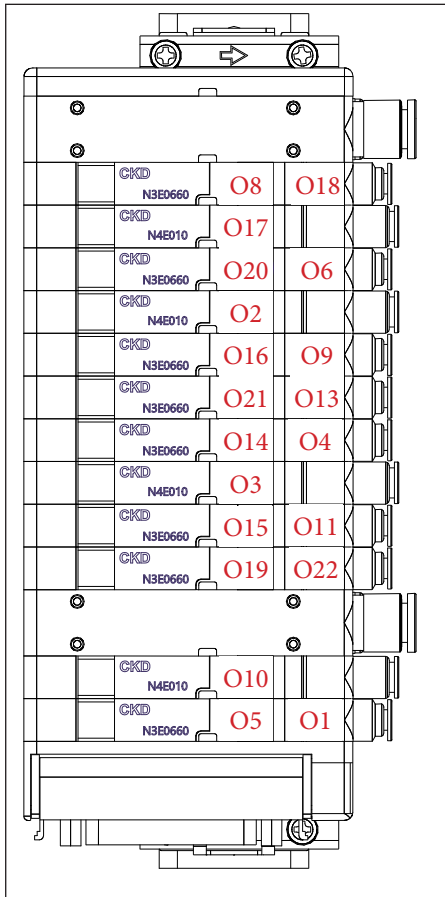

Valve assembly

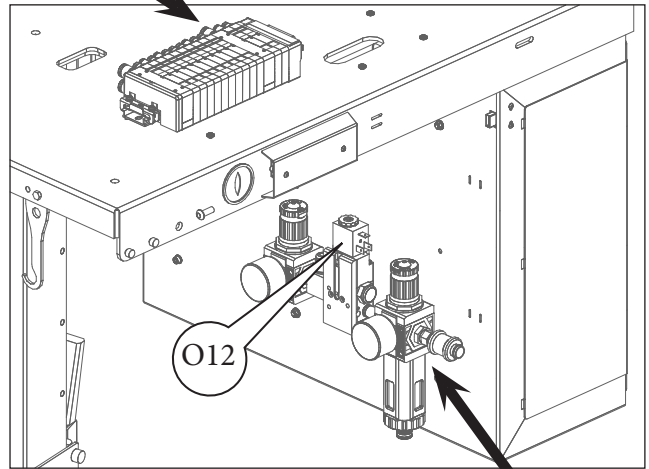

O12

General air assembly

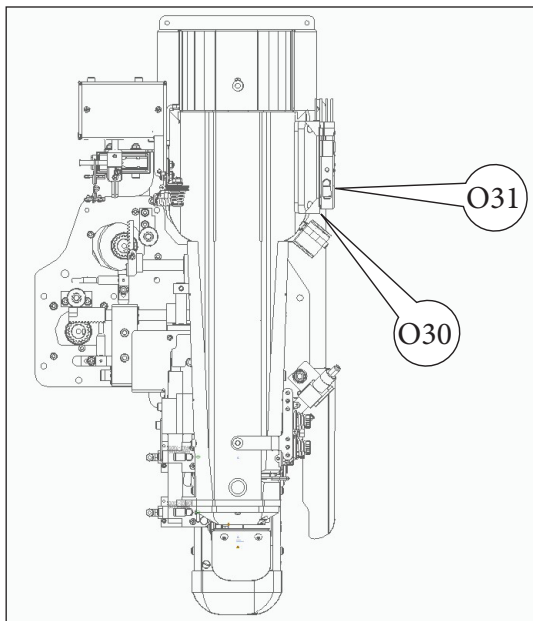

O31

O30

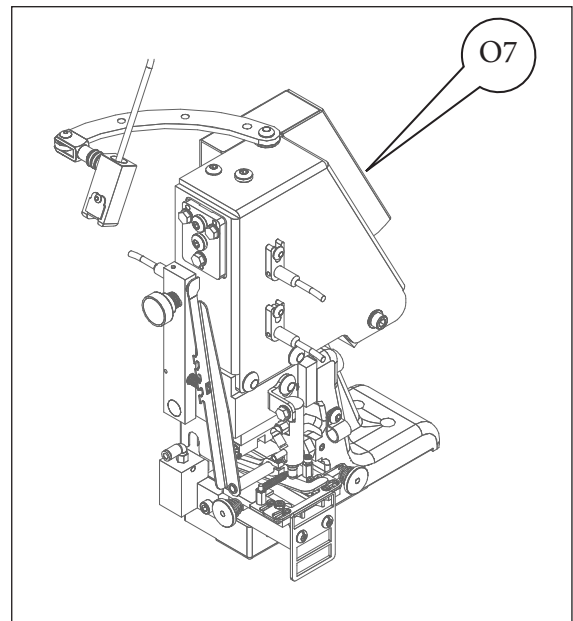

O7



16.3- Loop cutting test

From the main menu press the MENU icon and then press TEST (N.B. the key must be turned).

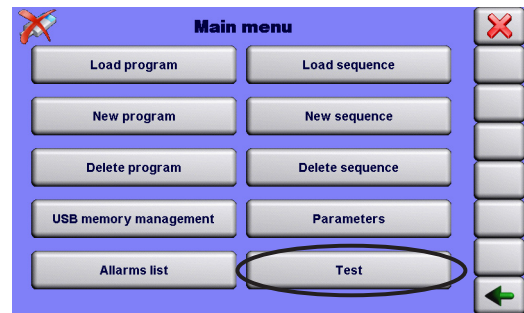
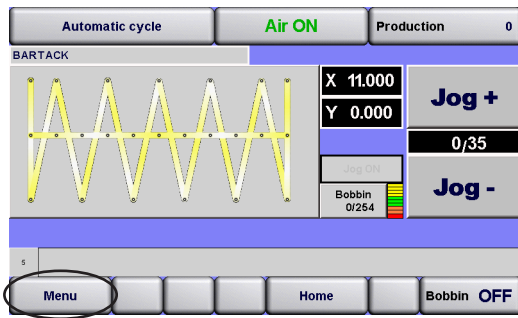

The following screen appears. Press CUTTING TEST and the screen appears with instructions to follow to carry out the loop cutting test, by pressing Manual Cut + Left Micro-switch, the loop cutting device, it will make a step by step movement of the loop cutting cycle, normally it is used to make adjustments when changing the loop cutting blade.

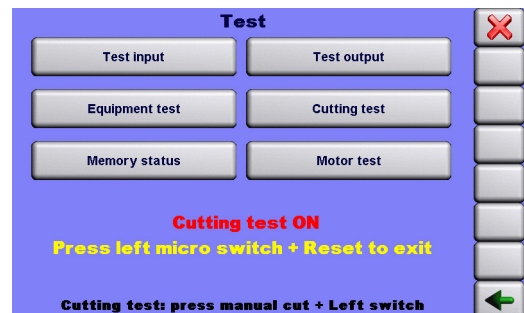
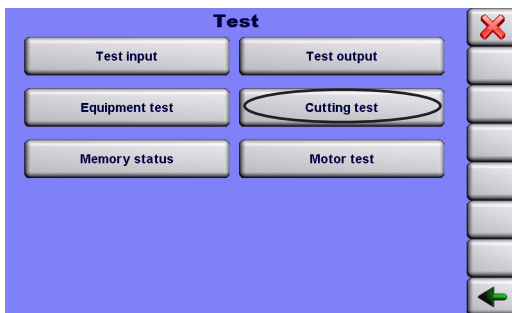

To close the test cycle and return to the previous screen or return to the main screen, follow the message found in the centre: press Left Micro-switch + RESET.

To return to the previous screen press 

To return to the main screen press 



16.4- Equipment test

From the main menu press the MENU icon and then press TEST (N.B. the key must be turned).

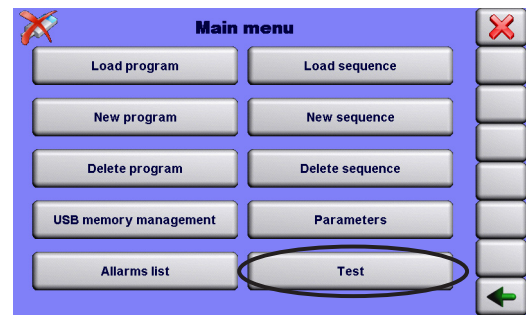
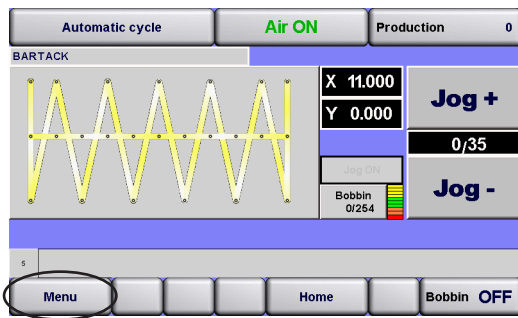

The following screen appears. Press EQUIPMENT TEST, and then the screen with the indications to follow to perform the Tests will appear. This function gives the possibility to carry out the entire cutting and loop loading cycle step by step, it is very useful to check the adjustments and make necessary adjustments if special fabrics or loops with various sizes are used.

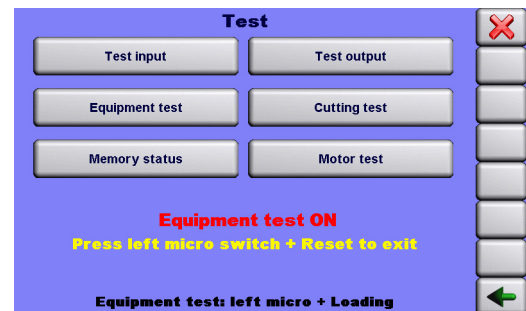
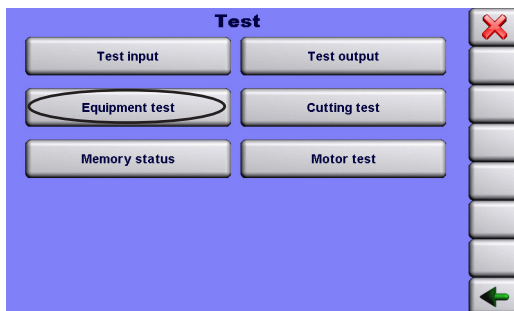

To close the test cycle and return to the previous screen or return to the main screen, follow the message: PRESS THE LEFT MICRO-SWITCH + RESET.

To return to the previous screen press 

To return to the main screen press 

16.5- Memory status

From the main menu press the MENU icon and then press TEST (N.B. the key must be turned).

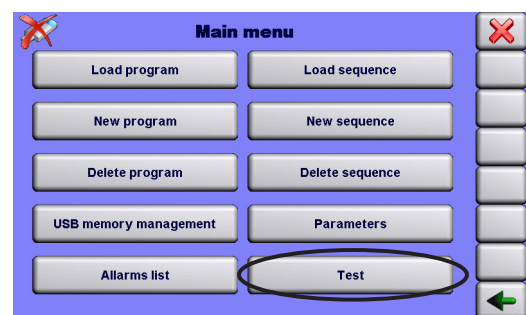
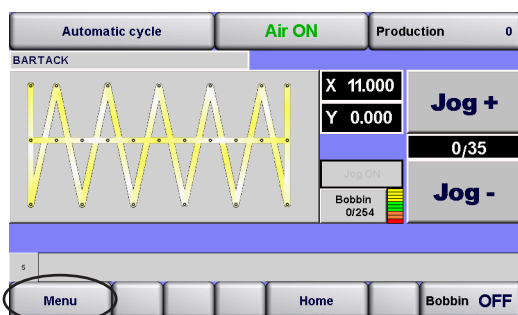

The following screen appears. Press MEMORY STATUS and will appear a screen with information on the machine's memory and the space used and that available.

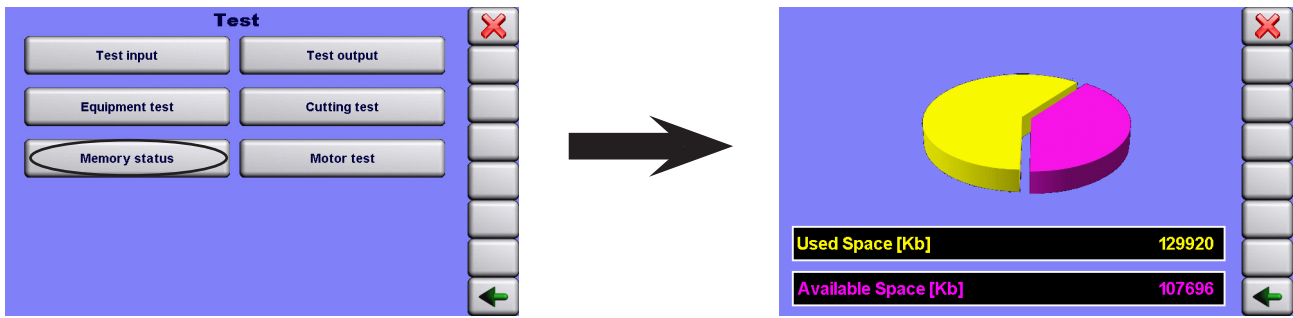

16.6- Motor test

From the main menu press the MENU icon and then press TEST (N.B. the key must be turned).

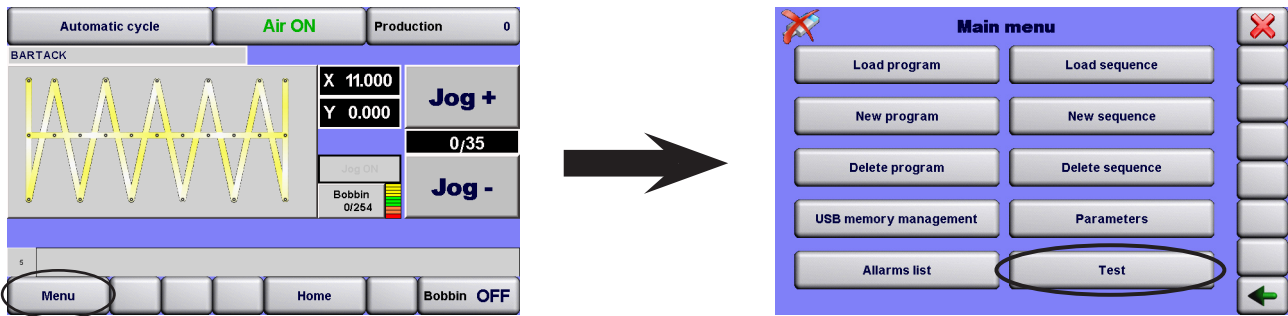

The following screen appears. Press MOTOR TEST and the following screen will appear where the user can check:

- Needle up position signal;
- Impulse reset, checking of the reset position of the motors step by step;
- XY impulse in motion, check movement on the X and Y axis towards the needle up position;
- Encoder Impulse, checks the correct operation and the Encoder test on the Mitsubishi motor;
- Possibility to check the movement of the motors on the X and Y axes step by step;

N.B. when the tests are finished, press the HOME button. This makes all the parts return to the initial position

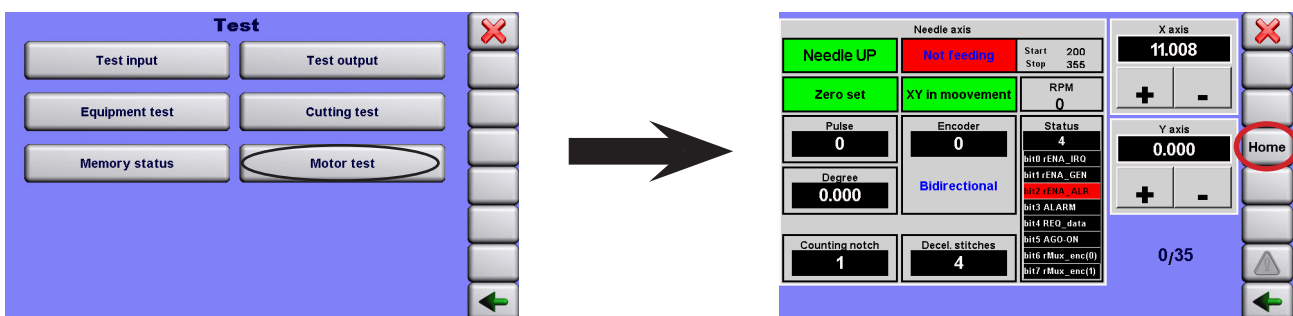

To return to the previous screen press

To return to the main screen press

When the user returns to the previous screen using the  button, the following screen is shown with the message PRESS ZERO + LEFT MICRO-SWITCH, follow the indications of the safety message and return to the main screen.

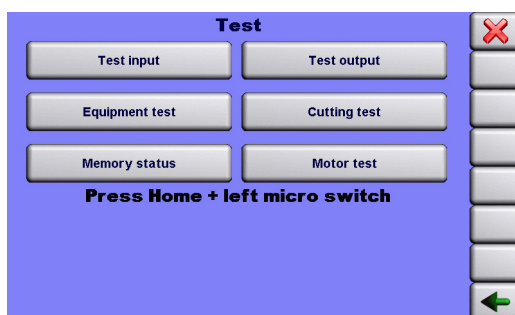

17. XLCE 554 SERVOMOTOR WITH XC GMFY PANEL

The unit is equipped with a MITSUBISHI servomotor. The motor is powered at a single-phase voltage of 220V 50/60 Hertz and with a consumption of about 550 Watts. The motor panel is GMFY, which controls and monitors all the speed phases, the thread cutting movement and the fabric holding by the presser foots. The basic setting of the various parameters is written in the BACKUP memory. In case of incorrect work, reset the memory panel following the specific indications (RESET).

17.1- Sewing speed

The unit can work with two different types of speed:



1. High speed
2. Slow start speed

17.1.1- High speed

To set the high speed proceed with the following sequence of operations:

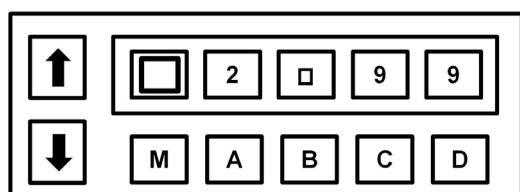
The following screen appears



Keep the  +  arrows pressed at the same time until the display shows: "P - P" (it means that we are in P mode) Press the  arrow repeatedly until the screen shown in the figure appears on the screen.

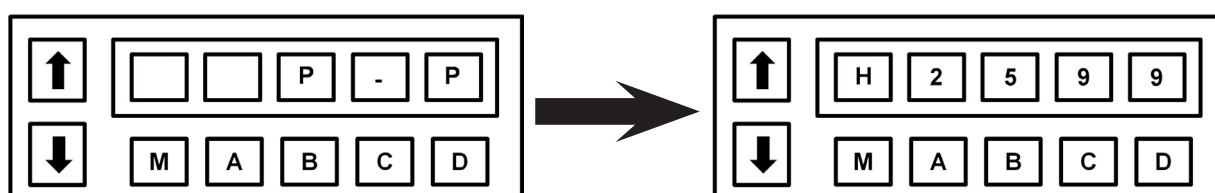

The value can be changed with the A - B - C - D buttons. (2599 is the standard value)

Hold down the  and  arrows at the same time to exit.



17.1.2- *Slow start speed*

You can see if this mode is active or not simply by looking at the display when the unit is ready to start a work cycle.



The symbol - indicates that slow start is deactivated (OFF), while the symbol □ indicates that slow start is activated (ON).

Press button B to change start status from activated (ON) to deactivated (OFF) and vice-versa.

Keep the  +  arrows pressed at the same time until the display shows: P - P (it means that we are in P mode) Press the  arrow repeatedly until the screen shown in the figure appears on the screen, (600 is the standard value).

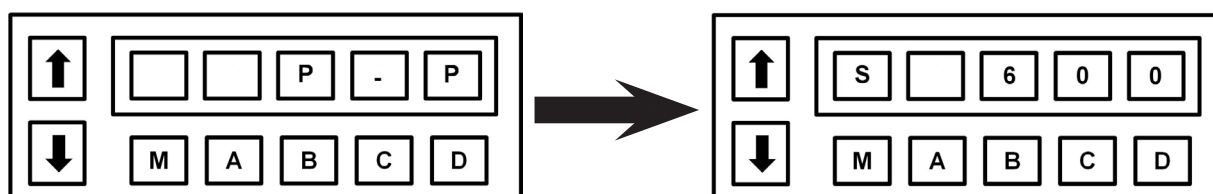

The value can be changed with the A - B - C - D buttons, set the value between 100 and 1000 revs.



17.1.3- *Setting the slow start number of stitches*

The unit, when it starts the sewing cycle, both in high speed and low speed, performs slow stitches. The operator can decide the number of these stitches from a minimum of 1 to a maximum of 5

Follow the instructions as shown in the following images.

The following screen appears. Keep the  +  arrows pressed at the same time until the display shows: P - P (it means that we are in P mode) Press the  arrow repeatedly until the screen shown in the figure appears on the screen.

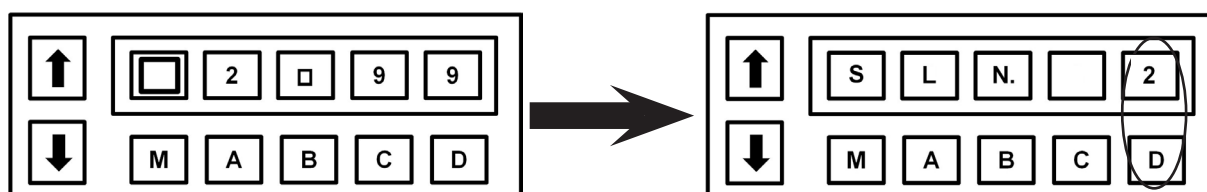

In this case the number of stitches that will be carried out at reduced speed is 2. To change this value simply press the "D" key

To return to the main page, press the  and  arrow simultaneously.

17.2- Setting thread trimmer parameters

The following screen will be shown on the control panel display:

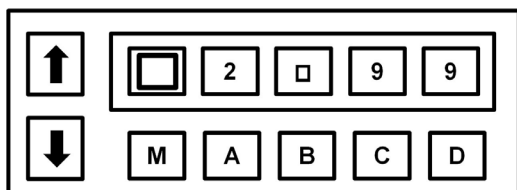

Press down on the $\uparrow + \downarrow$ arrows + the C button simultaneously until the following message will appear on the display: P-G (it means that we are in G mode) Then the display shows the screen found in the image. (trimming type setting)

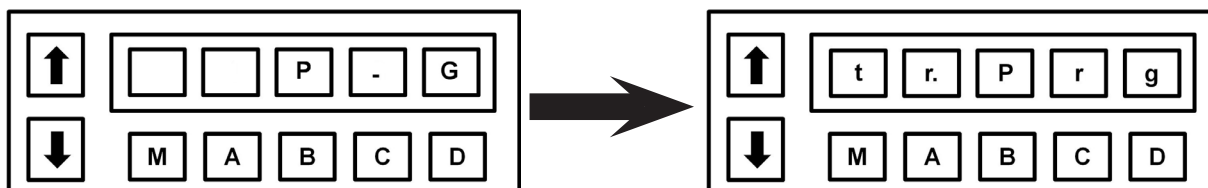

Press the \downarrow arrow repeatedly until the screen shown in the image appears on the display.

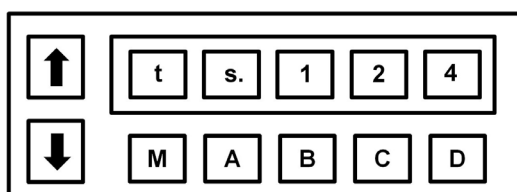

TS = value in degrees of one revolution of the unit
Start MOBILE KNIFE with the NEEDLE LOW signal

(124 is the standard value)

With the A - B - C - D keys it is possible to change the value and set it between 100 and 140. Increasing the value delays the start of the thread coupling hook; when the value is reduced, the start of the thread coupling hook is advanced.

Press the \downarrow arrow repeatedly until the screen shown in the image appears on the display.

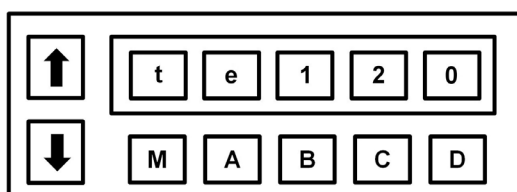

TE = value in degrees of the machine revolutions
Return MOBILE KNIFE with the NEEDLE LOW signal

Change the value, and set it to 120 with the A - B - C - D buttons. By increasing the value, the return of the thread coupling hook is delayed; when the value is reduced, the return of the thread coupling hook is advanced.

Press the \downarrow arrow repeatedly until the screen shown in the image appears on the display.

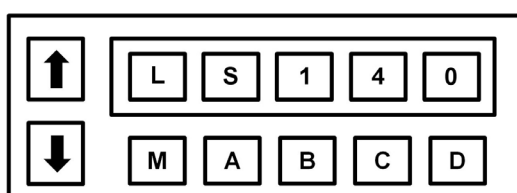

LS = value in degrees of the machine revolutions
Thread release opening tension and start of the thread wiper
With the NEEDLE DOWN signal

Change the value, and set it to 140 with the A - B - C - D buttons. Increasing the value, the opening of the tensioned disks and the movement of the thread scrap are delayed; when the value is decreased, the opening of the tensioned disks and the movement of the thread scrap are advanced.

Press the ↓ arrow repeatedly until the screen shown in the image appears on the display.

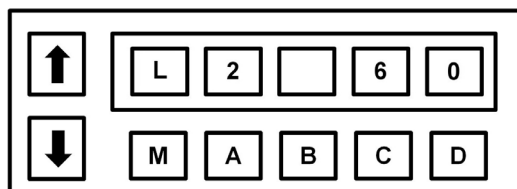

L2 = time value in msec
Thread release closing tension and return of the thread wiper
With the NEEDLE UP signal

Change the value, and set it to 60 with the A - B - C - D buttons. Increasing the value, the closing of the tensioned disks and the return of the thread scrap are delayed and the cut is more regular. When the foot is lifted, make sure that it does not touch the thread scrap. If needed, adjust the F1 parameter.

Decreasing the value, the closing of the tensioned disks and the return of the thread scrap are advanced and the cut is more irregular. Check that the knife has already cut the thread; if necessary, adjust the TE parameter.

Press the ↓ arrow repeatedly until the screen shown in the image appears on the display.

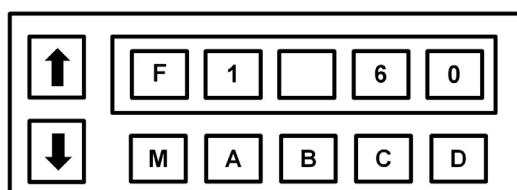

F1 = time value in milliseconds
Foot lifting delay with the NEEDLE UP signal

Change the value, and set it to 60 with the A - B - C - D buttons. By increasing the value, the lifting of the foot is delayed but, consequently, the time of the sewing cycle increases.

When the value is decreased, the lifting of the foot is advanced. When the foot is lifted, make sure that it does not touch the thread scrap. To exit press the ↑ and ↓ arrows simultaneously.

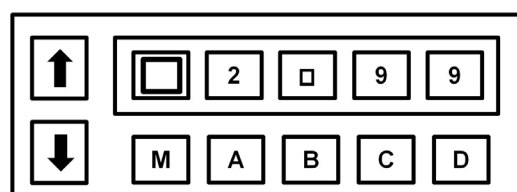

17.2.1- Reset

WARNING: with this procedure the data saved in the internal memory of the unit with the last BACKUP operation, or in the factory settings, or in the basic settings “type 280 M” are called up.

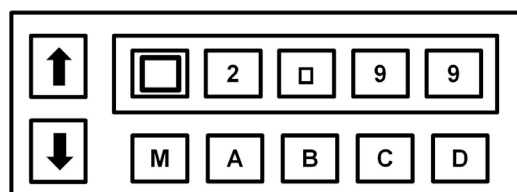

Simultaneously press the ↓ arrow, the “B” and “C” buttons, the “P - r” message appears on the screen. (it means that we are in R mode) Then the display shows the screen seen in the image.

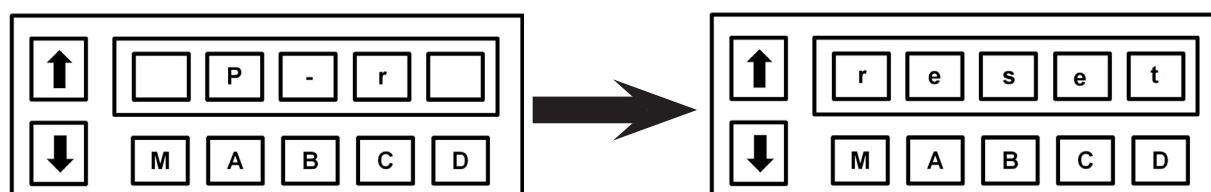

Press and hold D to restart the reset cycle.

It usually takes 6–7 seconds; the word “RESET” flashes three times.

Hold down the ↑ and ↓ arrows at the same time to exit.

17.3- List of errors

The display shows error messages when the unit detects anomalies during operation.

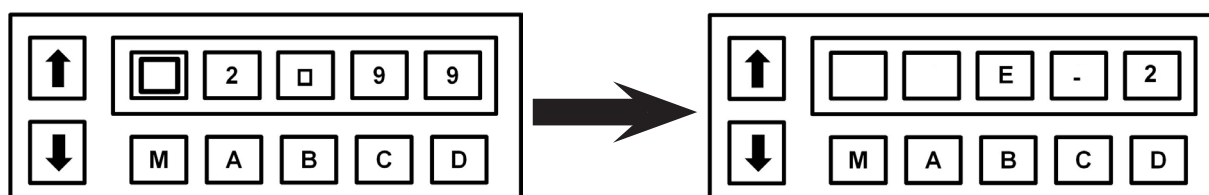

It is possible to see the last 4 errors by simultaneously pressing the **↑** + **↓** arrows + “A” button
A list of the errors that can appear on the screen are shown below.

E-1	<p>Check that the motor power supply connector is correctly inserted Check that during the functioning of the machine there aren't vibrations on the control box because with the vibrations the welding get damaged and give problems to the POWER PACK. In this case require the anti vibration Kit and control the condition of the belt.</p> <p>The vibrations increase this defect it can happen that reducing the speed the machine works without giving this error.</p> <p>If reducing the speed the problem disappears, check:</p> <ul style="list-style-type: none"> - That the motor is well fixed on the table. - Check that the encoder is clean and that the reading discs inside respects the correct position and the encoder is at the correct distance from the disk. <p>If the problem persists please contact VI.BE.MAC</p>
E-2	<p>Check the line tension(OVERVOLTAGE) The control box resists to a maximum tension of 260v over that E2 appears In a lot of cases this problem appears if connected to 380v ,and the control box is burned</p>
E-3	<p>Check if the connector ENCODER on the control box is connected. Check if the ENCODER is working correctly using the control box test parameters (ECA e ECB paragraph 17.4) Check that the machine is not jammed by turning the hand well. Check that the motor is not jammed Look at the connector to see if there are any burned marks on any pin or if there are any pins that have a bad contact Try to RESET the control box (paragraph 17.2.1) Check if there are any burned pins between the control box and the motor connector.</p>
E-4	<p>Check if there are any burned pins between the control box and the motor connector</p>
E-6	<p>This problem is caused by a disturb on the INPUTS Check if there are any disturbs on the inputs</p>
E-8	<p>Check that the machine is not jammed by turning the hand well. Check the connection of the synchronizer Check that the belt is correctly tensioned and that it doesn't slide</p>
E-9	<p>Control if there are any sensors or electro valves in short circuit Control if the setting is correct</p>

17.4- Test input e output

The following screen will be shown on the control panel display:

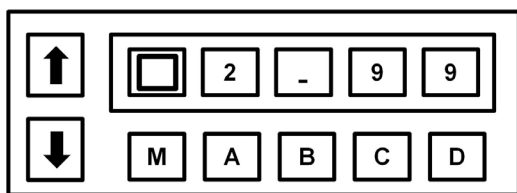

Hold down the **↑** + **↓** arrows + the A button simultaneously until the message P - E appears on the screen (this means that we are in E mode) and then the screen shown in the image appears.

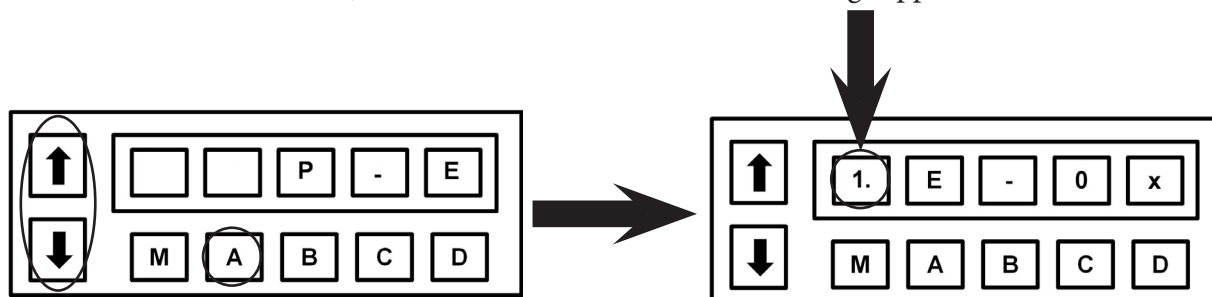

The number displayed in the first position identifies the position of the message, while the other messages identify an error message shown by the unit. (1-> last position then the last error message shown by the unit, 4-> fourth last position then fourth last error message shown by the unit. Pressing the **↓** arrow it is possible to change this number in order to see all 4 messages that appeared

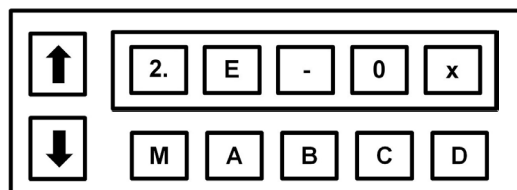

The display shows the second to last error message shown by the unit. Press the down arrow The screen shows:

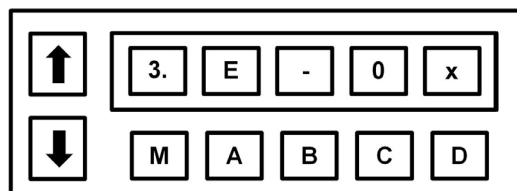

The display shows the third to last error message shown by the unit. Press the down arrow The screen shows:

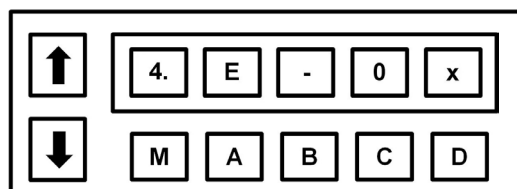

The display shows the fourth to last error message shown by the unit. Press the down arrow The screen shows:

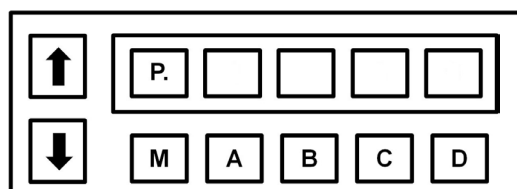

Hours of motor switch ON in real time
The value must be multiplied by ten
(total hours = No. X 10)

Press the down arrow The screen shows:

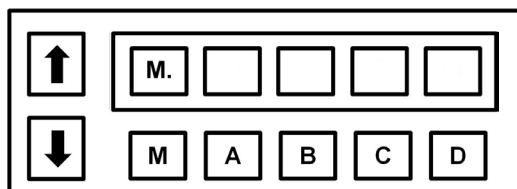

Hours of motor rotation in real time
The value must be multiplied by ten
(total hours = No. X 10)

Press the down arrow Display of all the INPUTs present (from IA to IP, from I1 to I5) with the possibility of manual control. The screen shows:

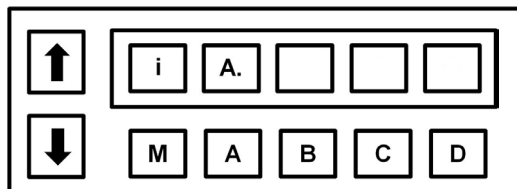

input parameter IA = OFF

The INPUT (ON/OFF) value of the IA parameter is displayed.

By changing the logical position of the relative INPUTs (pedal-switch-detector-photocell), the value changes from OFF to ON. Press the down arrow to review the following parameters:

SCREEN	FUNCTION
I1	START signal
I2	STOP signal

When the screen shows:

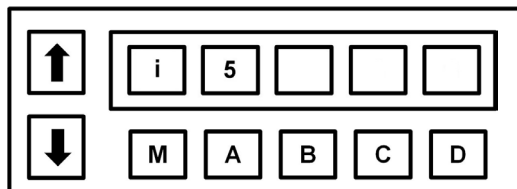

input parameter I5 = OFF

The INPUT (ON/OFF) value of parameter I5 is displayed.

Press the down arrow The screen shows:

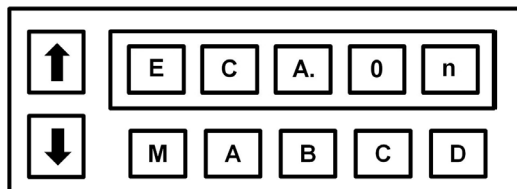

motor A phase encoder input parameter

The INPUT (ON/OFF) value of the E C A parameter is displayed.

By turning the machine by hand, the value changes continuously between ON and OFF.

Press the down arrow The screen shows:

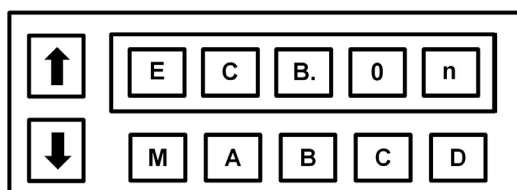

motor B phase encoder input parameter

The INPUT (ON/OFF) value of the E C B parameter is displayed.

By turning the machine by hand, the value changes continuously between ON and OFF.

Press the down arrow The screen shows:

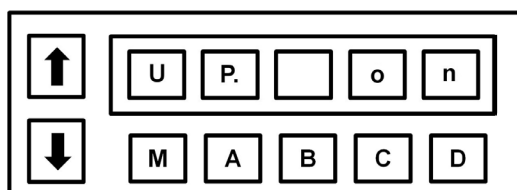

Hand wheel detector parameter - Upper stop position
Thread UP taker check

The INPUT (ON/OFF) value of the UP parameter is displayed.

By turning the pulley on the sewing head it is possible to change the value between ON and OFF.

Press the down arrow The following shows on the screen:

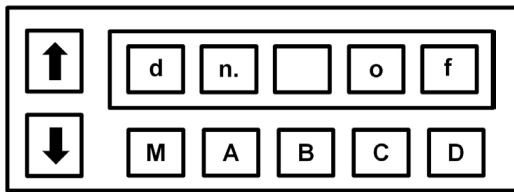

input parameter of the NEEDLE DOWN position detector reading

The INPUT (ON/OFF) value of the **dn** parameter is displayed.

By turning the pulley on the sewing head it is possible to change the value between ON and OFF.

Press the down arrow

The OUTPUT signal value of the **0Ad** parameter is displayed.

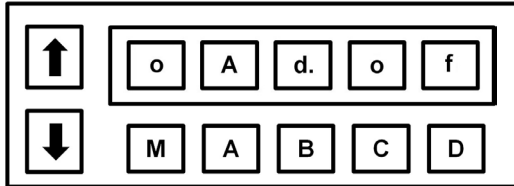

Input signal 0 P = OFF

Press the down arrow to see the following parameters:

PARAMETER FUNCTION

- o D d Open + thread wiper & tension signal
- o l d Thread cutter (trimmer) signal

**OUTPUTS STATUS
DURING THE SEWING
CYCLE**

Display of all OUTPUTS with manual control - TO BE USED FOR THE CONTROL OF HARDWARE SETTINGS (from OA and OR).

The screen shows:

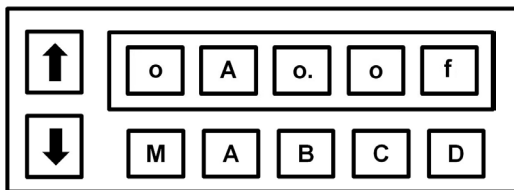

0A output signal

The OUTPUT signal value of the 0Ao parameter is displayed.

Press button D to change the value from OFF to ON.

Press the down arrow to review the parameters set at the factory, which are generally the following:

- oDo Open thread tension and wiper signal
- oIo Thread cutter (trimmer) signal

The screen shows:

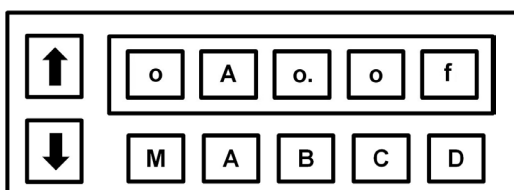

0P output signal = OFF

To exit press the **↑ + ↓** arrows simultaneously

The control panel display shows:

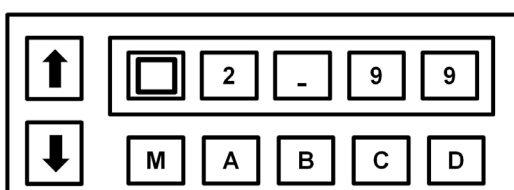

17.5- Parameter setting

Buttons to be pressed simultaneously to select the different types of menus:

Menu A	Down arrow + A
Menu C	Down arrow + C
Menu D	Down arrow + D
Menu G	Down arrow + up arrow + C
Menu F	Down arrow + up arrow + B
Menu H	Down arrow + Up arrow + D
Menu J	Down arrow + Up arrow + A + B
Menu K	Down arrow + Up arrow + A + C
Menu P	Down arrow + up arrow

Function number	Mode	Digital	Function name	4650 EV9@UP2
	NORMAL	CW.	Rotation direction	R
0000	P	H.	Maximun speed	2599
0001	P	L.	Low speed	220
0002	P	T.	Thread trimming speed	199
0003	P	N.	Start tacking speed	1000
0005	P	M.	Medium speed	500
0006	P	S.	Slow start speed	600
0007	P	SLN.	No. of slow start stiches	1
0010	P	SH.	One shot	ON
0011	P	SHM.	One shot operation mode	RH
0021	P	FUM.	Presser foot lift momentary	ON
0024	P	FD.	Time to motor drive after presser foot lifter bring down	0
0027	P	FUD.	Presser foot lifting output chopping duty	FL
0029	P	FL.	Cancel the presser foot lifting with full heeling	ON
0030	P	S3L.	Cancel presser foot lifting with light heeling	ON
0040	P	S2R.	Full heeling, S2 signal operation mode	OF
0041	P	IL.	Cancel of interlock after full pedal heeling	ON
0042	P	TR.	No. of stitches setting for auxiliary feeding rear roller	PRG
0047	P	K8.	Reverse run angle from DOWN position to UP position	120
0051	P	KD.	Virtual down Setting	ON
0054	P	D8.	Needle DOWN position stop angle	48
0102	A	AC.	Acceleration time simple setting	L
0103	A	ACT.	Acceleration time	6
0104	A	DC.	Deceleration time simple setting	-
0105	A	DCT.	Deceleration time	10
0107	A	SCT.	S-character cushion time setting	0
0110	A	MR.	Setting motor pulley diameter	200
0111	A	SR.	Setting sewing machine pulley diameter	200
0114	A	STM.	First priority stop → speed control	ON
0300	C	IA.	Function selection of input signal IA	NO
0309	C	ID.	Function selection of input signal ID	NO
0312	C	ID.	Function selection of input signal D	NO
0315	C	IF.	Function selection of input signal IF	NO

0348	C	IP.	Function selection of input signal IP	NO
0357	C	I1.	Function selection of input signal I1	S4
0370	C	I2.	Function selection of input signal I2	PSU
0390	C	OA.	Function selection of output signal OA	NO
0395	C	OB.	Function selection of output signal OB	NO
0400	C	OC.	Function selection of output signal OC	NO
0410	C	OF.	Function selection of output signal OF	NO
0412	C	FUD.	Presser foot lifter output chopping duty	FL
0416	C	01.	Function selection of output signal 01	T
0421	C	02.	Function selection of output signal 02	NO
0426	C	03.	Function selection of output signal 03	NO
0431	C	04.	Function selection of output signal 04	NO
0435	C	05.	Function selection of output signal 05	NO
0473	C	PO.	Full wave output time for each output	100
0528	C	E.	Speed setting for the [SPE] output	1000
0600	D	D1.	Operation mode during tacking	N
0625	D	PNE.	End tacking cancel mode with input signal PSU	ON
0900	G	TR.	Thread trimming mode	PRG
0902	G	LTM.	Thread trimming outout (T) output mode	T2
0904	G	TS.	Thread trimming output start angle	124
0905	G	TE.	Thread trimming output angle	120
0906	G	LS.	Thread release output start angle	140
0907	G	LE.	Thread release output angle	140
0911	G	L2.	Thread release output time	60
0918	G	F1.	Presser foot lifting output start time	60
0919	G	FD.	Time to motor drive after presser foot lifter bring down	0
1000	H	LHH.	Upper limit of maximum speed [H]	26
1002	H	LLH.	Upper limit of low speed [L]	3
1004	H	LTH.	Upper limit of thread trimming speed [T]	2
1006	H	LNH.	Upper limit of start/end tacking (condensed stitching) speed	20
1008	H	LMH.	Upper limit of medium speed [M]	20
1102	J	CWC.	Rotation direction changeover prohibit	ON
1103	J	12C.	1-2 position changeover prohibit	ON
1106	J	JKC.	Not used	ON
1107	J	SBC.	Start tacking validity changeover prohibit	ON
1109	J	EBC.	End tacking validity changeover prohibit	ON
1110	J	ENC.	No. of end tacking stitches changeover prohibit	ON
1111	J	SKC.	Start tacking type changeover prohibit	ON
1112	J	EKC.	End tacking type changeover prohibit	ON
1113	J	TSC.	Pattern stitching validity changeover prohibit	ON
1114	J	TNC.	Pattern stitching No. of stitches and times changeover prohibit	ON
1116	J	BAC.	Prohibit the all of key switches on control switch panel	ON
1225	K	NAN.	Deceleration mode	ON

18. LOOP CUTTING DEVICE



CAUTION!

Before making any adjustments, turn OFF the machine by pressing the red emergency button on the left of the stand table.

18.1- Adjustment of the loop cutting device position

The external side of the loop cutting protection cover must not be touching the loop loading carriage when is passing to the intermediate position; the distance between these two parts must be approximately 2 mm.

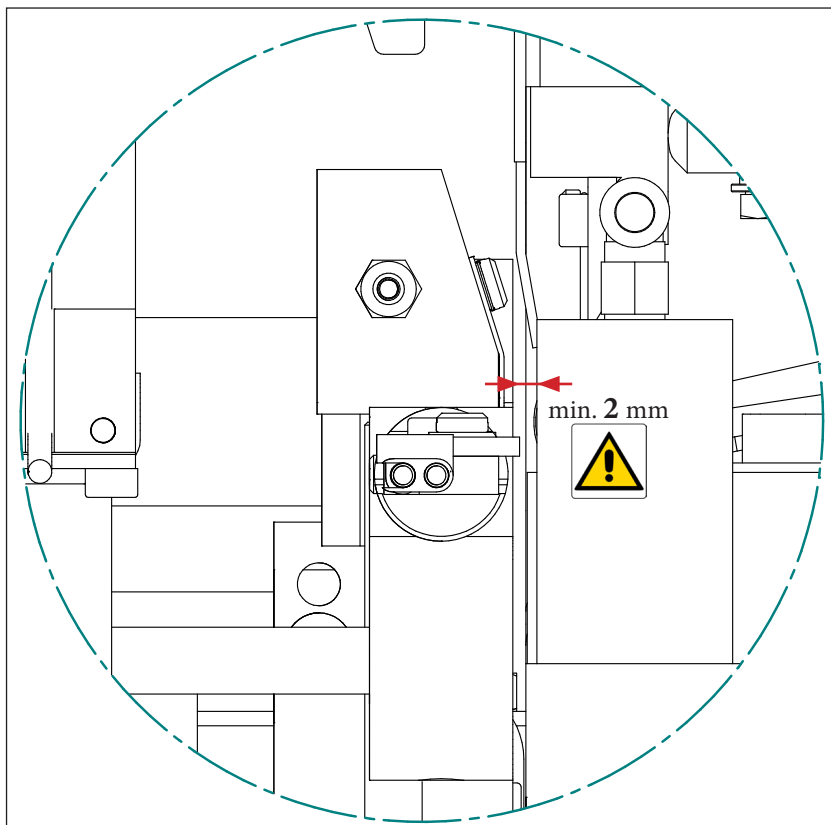
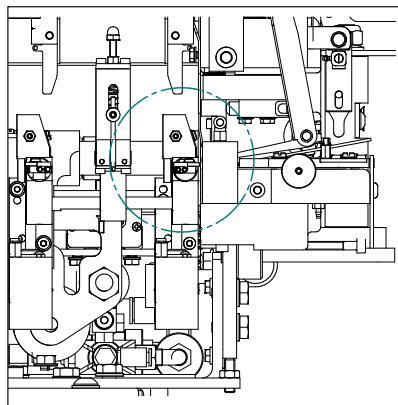

To move the position of the loop cutting device, loosen the fixing knob and then move the loop cutting device. Remember to fasten the knob when the adjustment is finished.

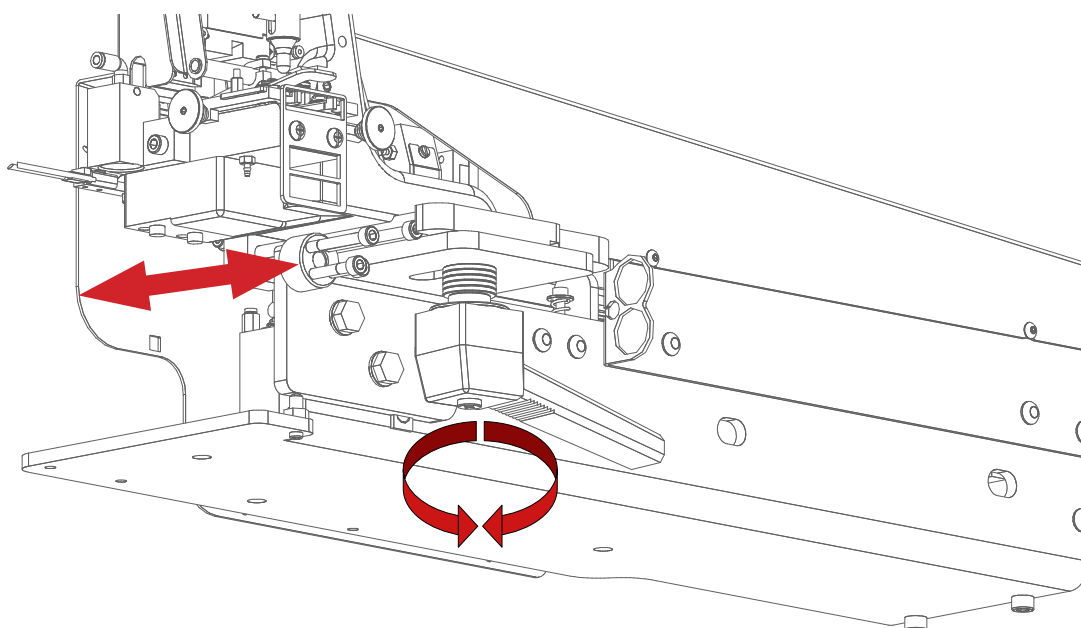

18.2- Adjusting the loop guide



The loop guide must be adjusted to allow the loop to enter and pass freely and to be centred according to the cutting blade rotation, the V shape of the loop must be centered.

To adjust the loop guides use the knobs.

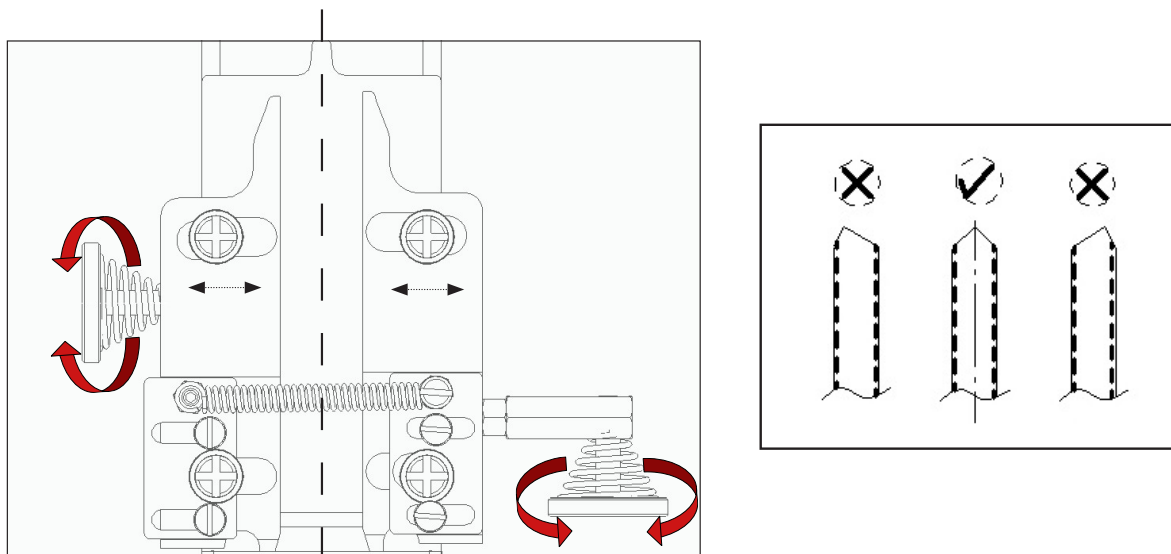

18.3- Adjusting the loop joint rejection

Insert a loop stripe under the loop spring retainer, loosen and tighten the detector lever fixing knob. The adjustment is completed. When loop joint will pass thru the guides the lever will move up and the sensor IN10 will activate the rejection of the loop joint.

Refer to the screen below to avoid errors.

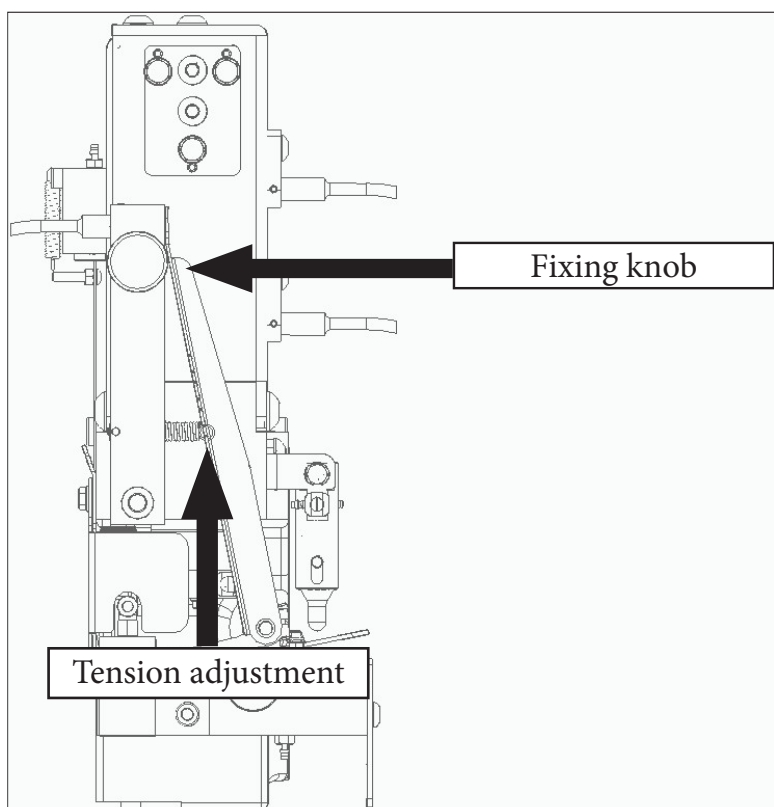

18.4- Loop joint length rejection adjustment



Insert the fabric between sensor No. 10 and the detector, call up a loop by pressing the left multi-function

micro-switch +  until the machine continues to carry out the loop joint rejection operation. At this point, set the cylinder speed using the regulator; if the speed is too slow, the cut is made at the end of the joint; if the speed is too fast, the loop piece with the joint will be longer. Adjust the speed to cut the loop 5-6 mm after the joint.

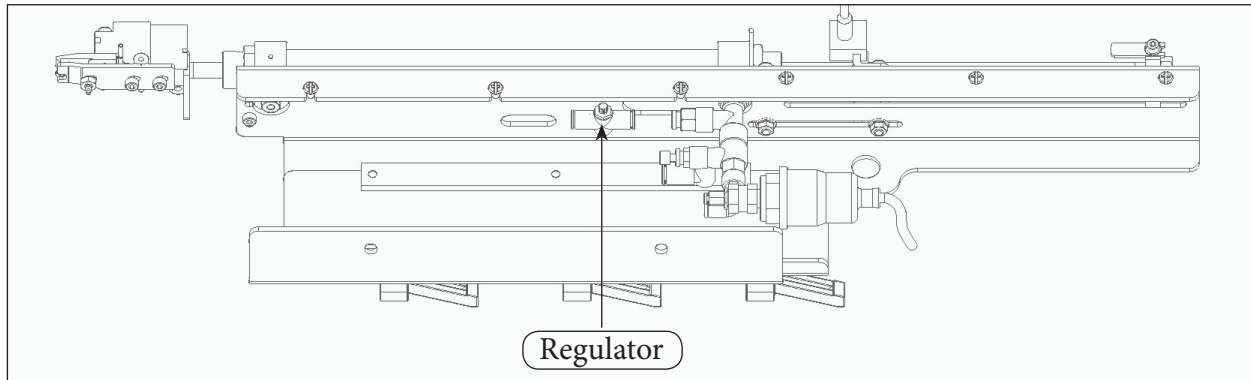

18.5- Adjusting the cutting system

The unit has the advantage of cutting a loop from 10 to 22mm without having to change the type of knife. The new device has a straight blade and performs the following sequence: first cut, rotation of the blade holder and final second cut. In the end, the loops are cut into a V shape; the knife has a STRAIGHT blade that is reliable and durable.



!CAUTION!

It is suggested to make this adjustment with a new knife. To change the knife Remember to ALWAYS remove the pneumatic power supply and remove the safety covers..

From the main screen, select the MENU icon; on the screen that appears select the CUT TEST mode; then press the “left multi-function micro-switch” and then press the button

LOOP CUTTING 

The blade holder turns on itself leaning on the fixed metal pins; the rotation movement of the blade holder must be fixed and without clearance between the surfaces of the parts.

By changing the position of the rotation cylinders, the V-shaped angular cut on the loop will also change backwards or forwards. Moving the cylinder block forward, the V-shaped cut will have a larger angle, while moving the cylinder block back the V-shaped cut will have a smaller angle.

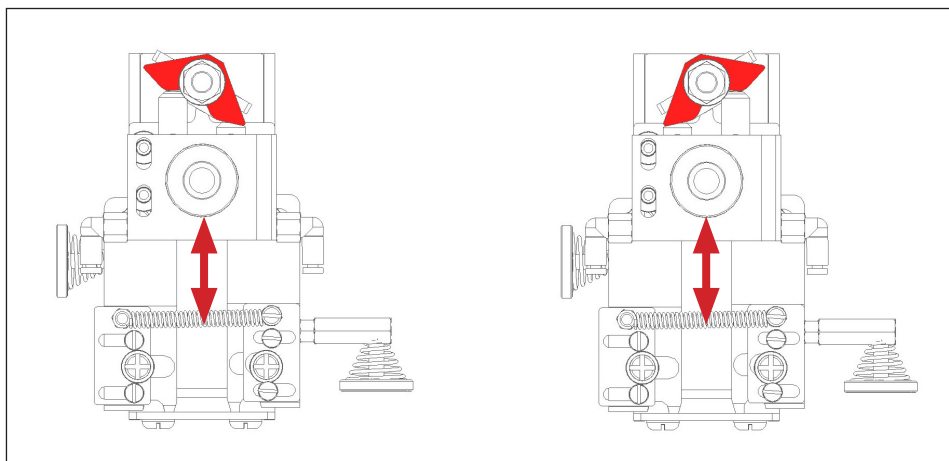

18.6- Adjusting the movement of the cutting cylinder



The up and down movement of the cutting cylinder has a fixed stroke. To adjust it, loosen the two screws A (image 1) and then turn the screw B for a quarter of a rotation at a time. If screw B is turned clockwise, the stroke of the cylinder will move upwards, if screw B is turned counter clockwise the stroke of the cylinder will move downwards.

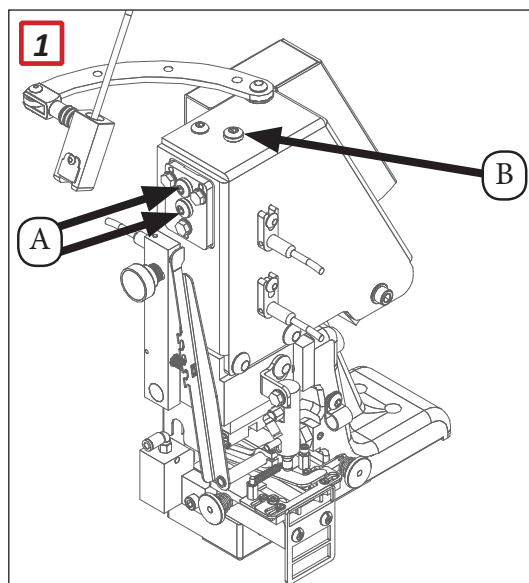

18.7- Adjustment of the hammer base position

When the cutting cylinder is in the low position the cutting blade must be parallel with the hammer base (image below) and must touch the entire length of the blade.

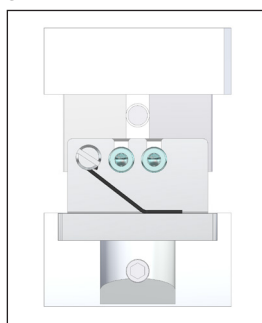

The parallelism between the cutting blade and the base can be adjusted by moving only the position of the base (loosen the fixing screws) (image 2). Rotating the four adjustment grab screw (image 3) the position of the hammer base can be corrected until there is a perfect parallelism.

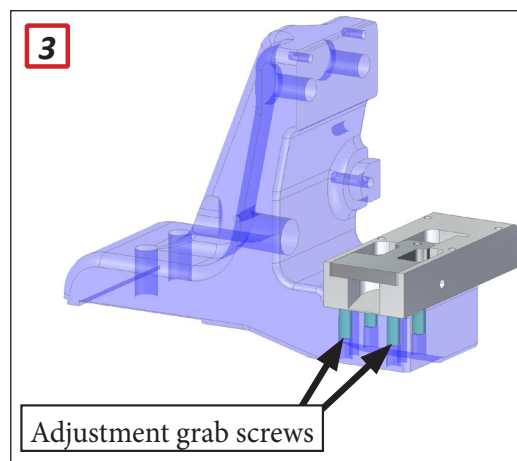
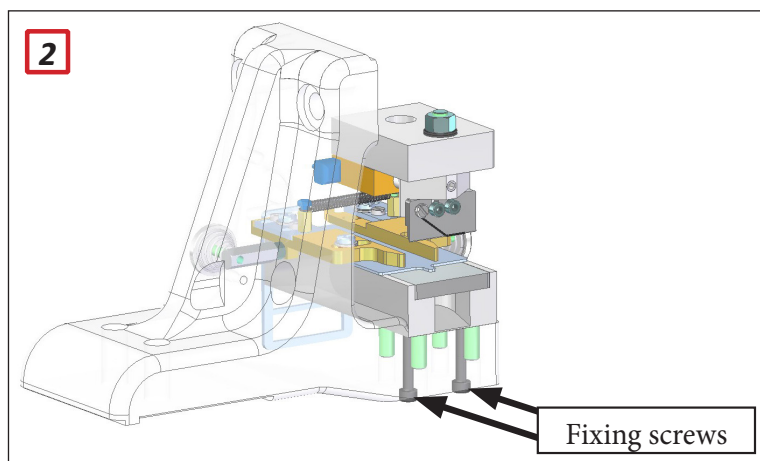

19. LOOP PULLING DEVICE



19.1- Adjustment of the loop pulling cylinder position

The loop pulling device in the forward position must not touch the support of the loop cutting device (image 4), to adjust the position the 3 fixing screws are loosened and the cylinder can be moved forward or backward (image 5).

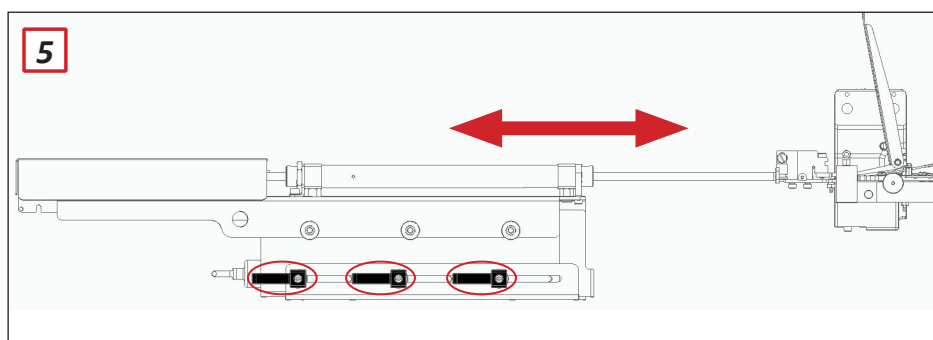
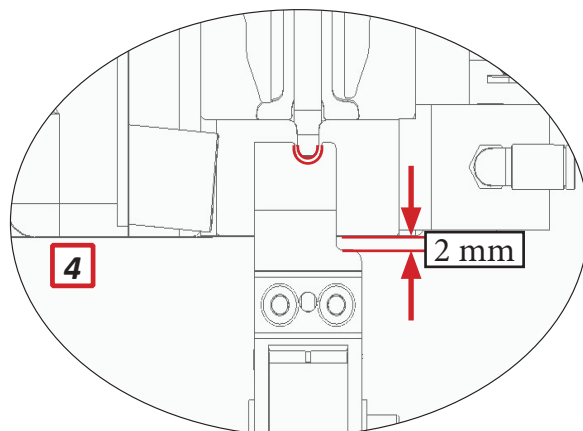

With the screws circled in image 6, it is possible to adjust the position of the loop pulling device so that the loop is perfectly straight and parallel with the table and at the same level as the forking pins. (See image 7)

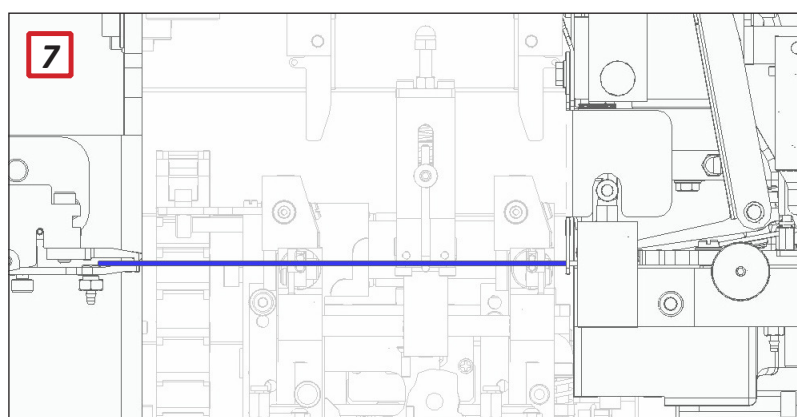
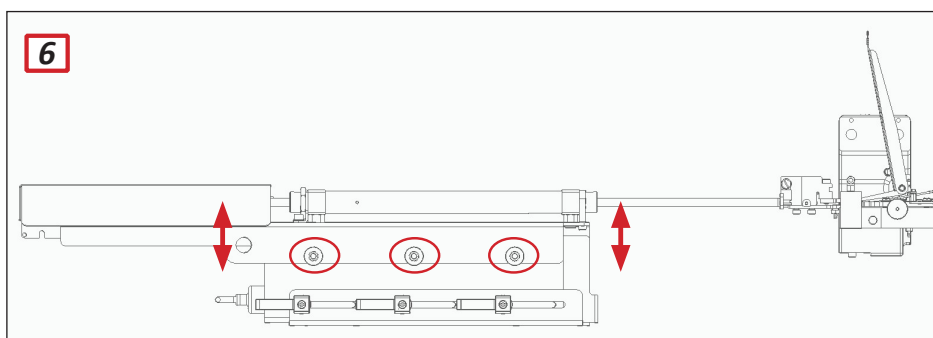



19.2- Adjustment of the loop length cylinder

The coloured block positioned on the loop length cylinder identifies the length of the loop (image 1). Unscrewing the fixing screw (image 2) and moving the block forward the loop will be shorter, while if it moves backwards the loop will be longer.

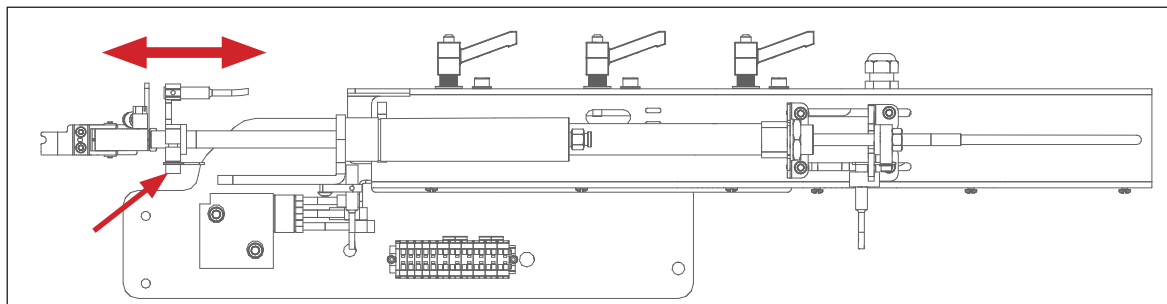
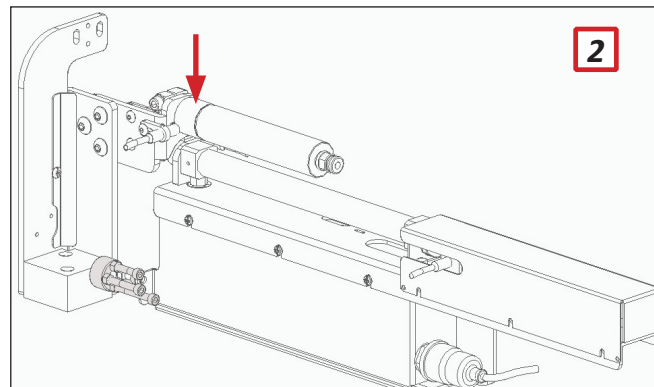
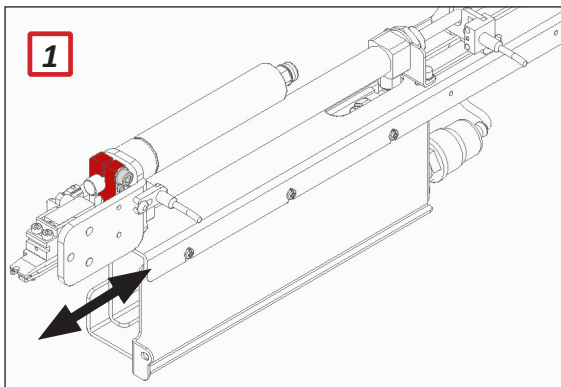

20. LOOP LOADING DEVICE

20.1- Loop forking

Call up the EQUIPMENT TEST function; carry out a loop preparation cycle, with the loop pulling cylinder completely back, continue with the subsequent sequential phase of the cycle.

The forking pins (clamping device) fit into the loop; check that the material is in the centre of the cylindrical pins with open V shape at the tip and that the material is not moved upwards or downwards.

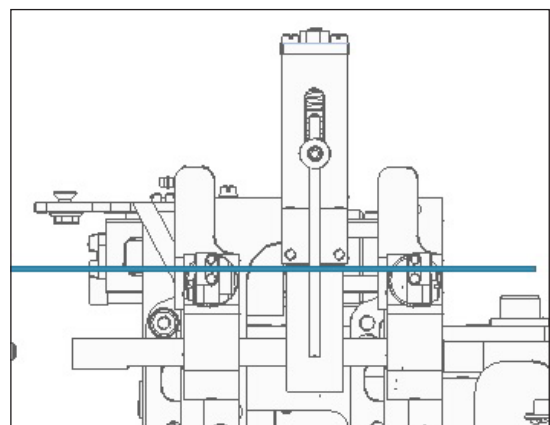
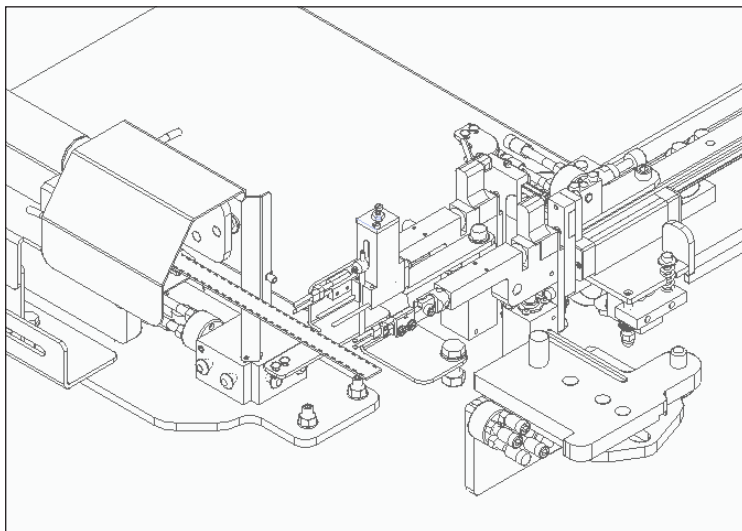

To adjust the fork height, loosen or tighten the screw shown in the figure with a 3 mm hex wrench.

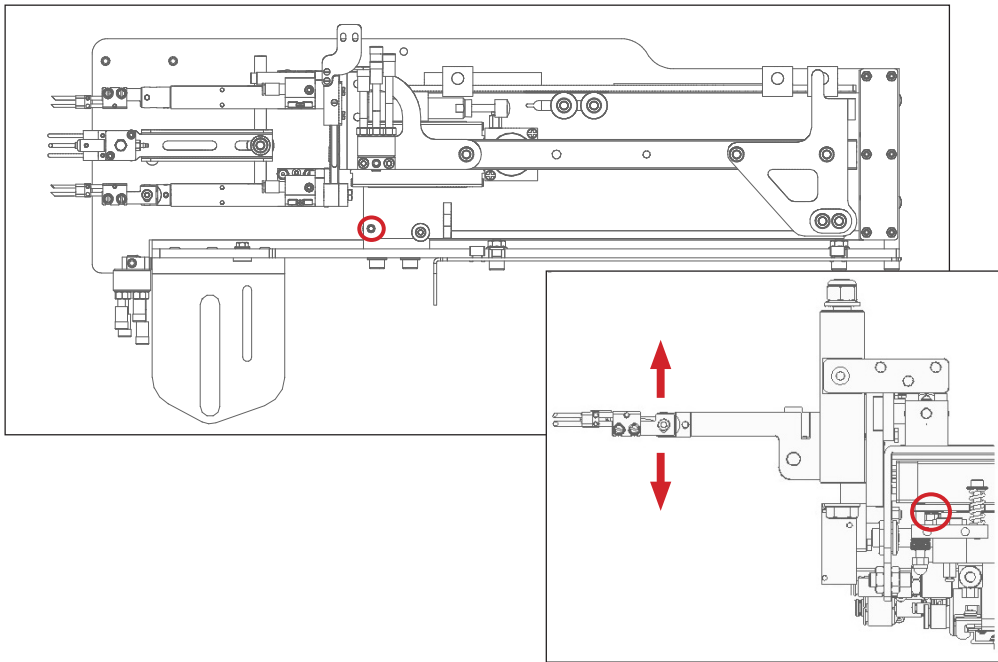

20.2- Loop forking position

Call up the EQUIPMENT TEST function; carry out a loop preparation cycle. After the carriage has forked the loop, continue with the next step sequence until the forking pins rotate.

The loop is correctly positioned when:

- the fork pins come 1 mm max. out of the loop on the left side
- the lower side of the loop is perfectly aligned with the upper part.

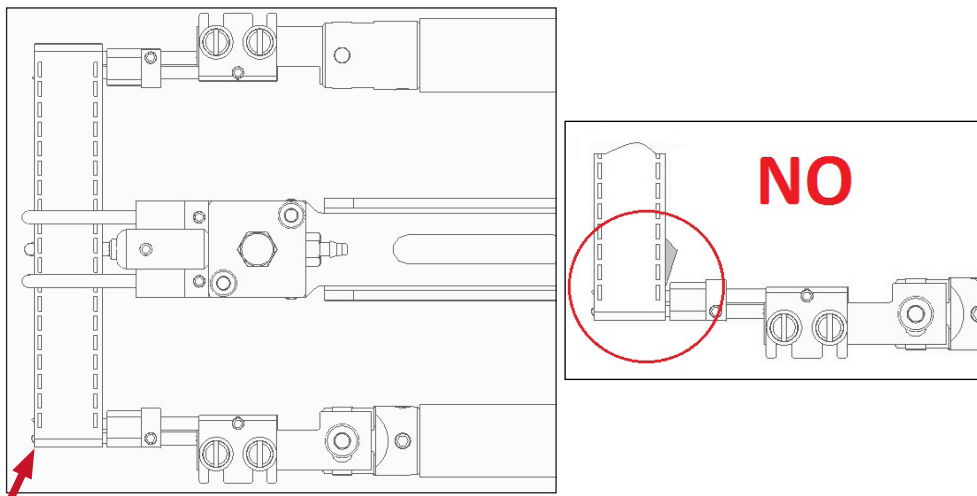

To adjust the forking position, have to lose the limit screw under the loop loading carriage and to adjust it accordingly.

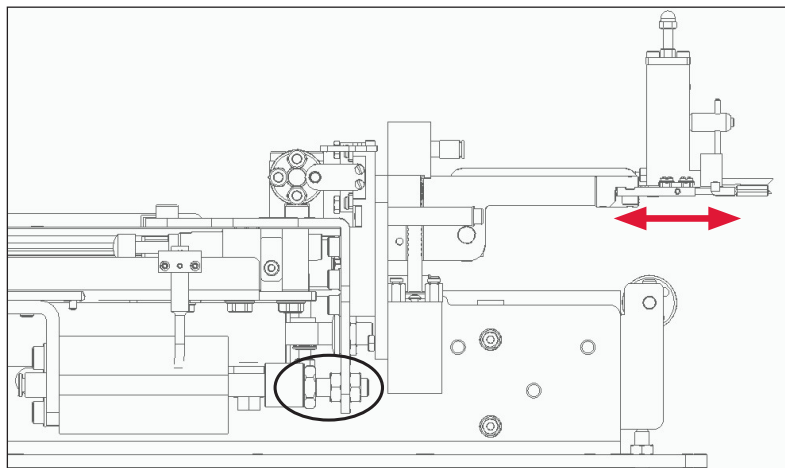

After the forking position is in fixed, the position of sensor number 4 must be adjusted correctly ; the bar positioned over the sensor must cover it for the entire right side and the height must be between 0.2 and 0.5 mm from the sensor.

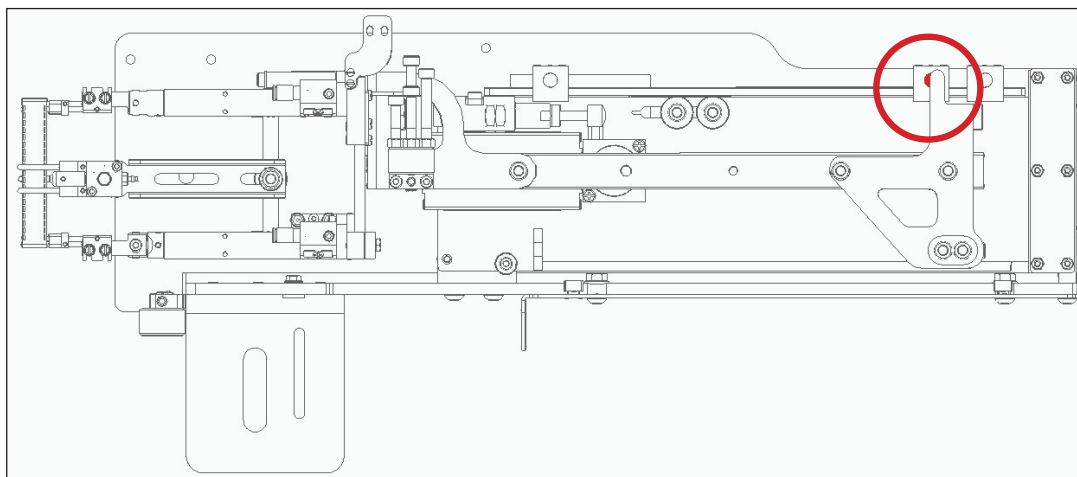

20.3- Loop stopper position on the forking pins

A safety STOPPER for the positioning of the loop shown in the image is positioned on the forking pins. The correct position is 1 mm from the loop.

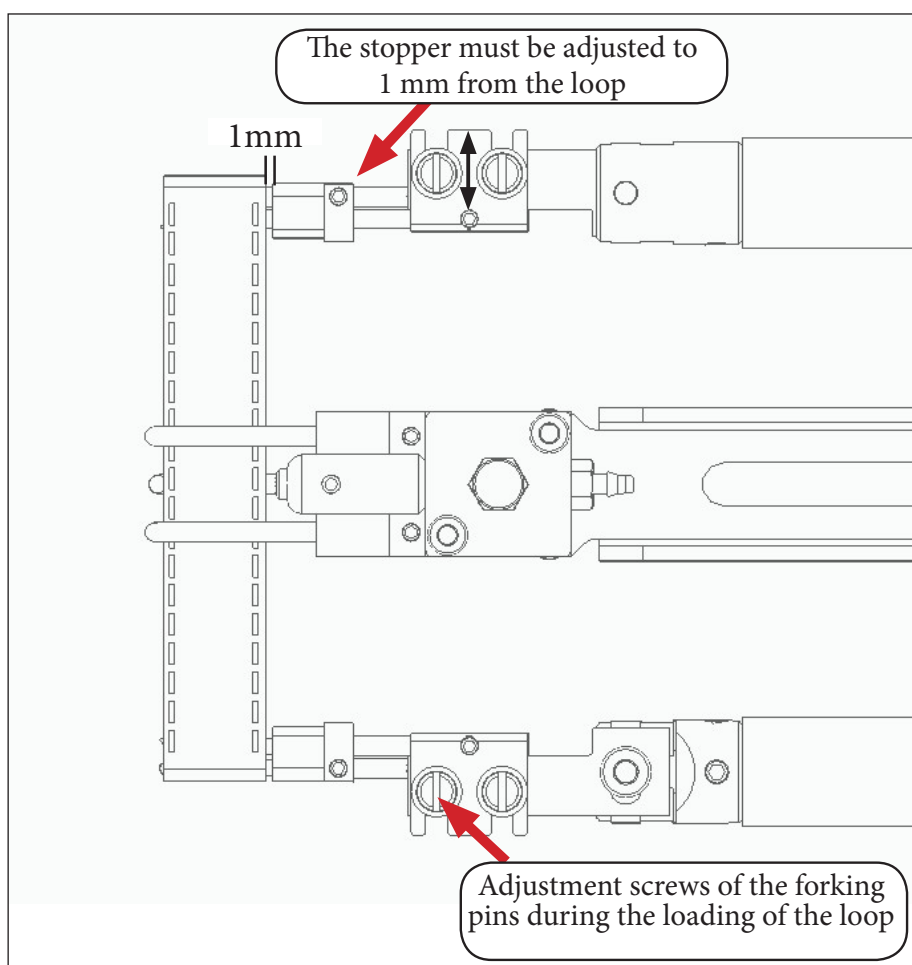

The forking pins must be parallel and the loop inside the clamping devices must be slightly clutched. The forking pins adjustment screws are shown in the image.

20.4- Adjusting the intermediate stopping position of the carriage

The intermediate stopping position of the loop loader is the position where the carriage stops with the loop ready to be sewn and waits for the operator to press the two multi-function switches to perform the sewing. The ideal stopping position with the best time/speed performance ratio is when the carriage stops on the same line as the yellow safety protection, as shown in the image below.

By changing the **TIMER 9** value, it is possible to adjust the position where the carriage stops. (**MENU-> PARAMETERS -> TIMER 9**) The value has been set by the factory at 175; Increasing it, the carriage will stop closer to the sewing head; decreasing it, the carriage will stop further from the sewing head

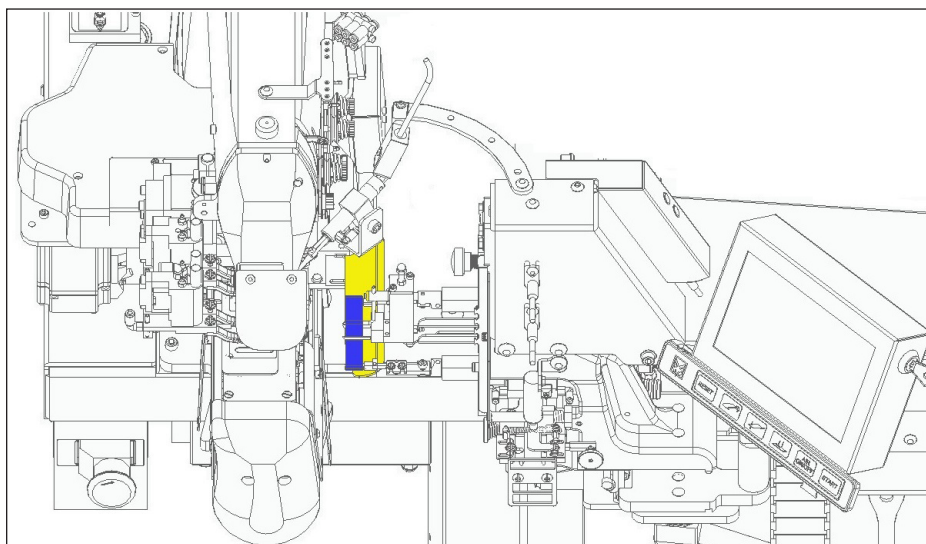

IN CASE OF INCORRECT POSITIONING:

- Check that the general air pressure is set at 5 bar,
- Check that the pressure regulator is adjusted to between 2/2.3 bar,
- Check that there is no leakage from the cylinder
- Check that the diaphragm inside the quick exhaust valve is not blocked or worn,

Before making any adjustments, the **BRAKE** and the **SLIDE** must be cleaned with a cloth, see image below.

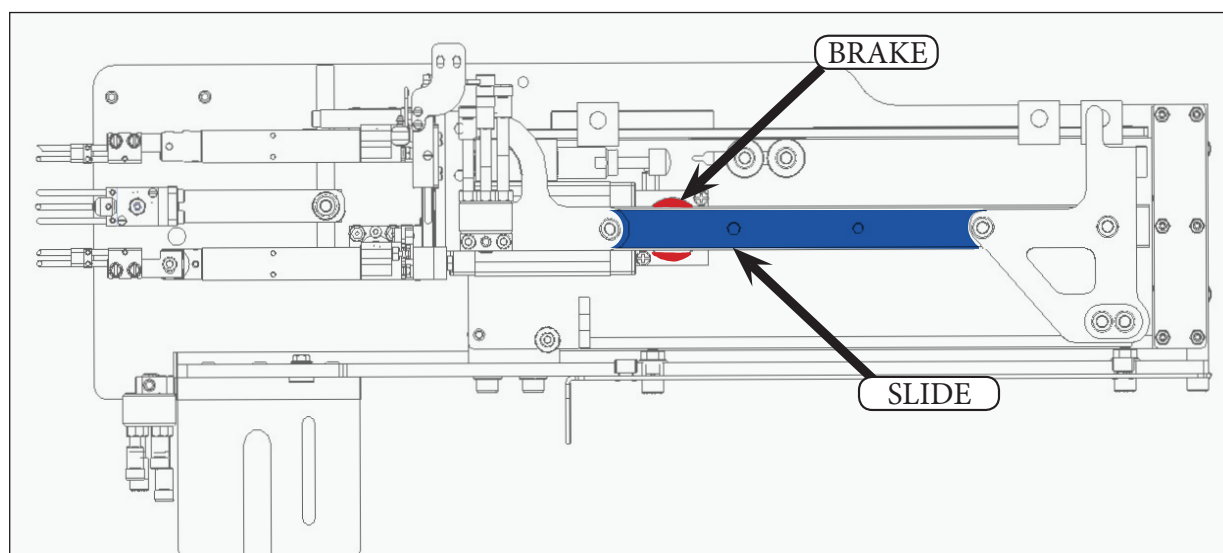

20.5- Adjusting the maximum forward position of the loop carriage



Call up the **EQUIPMENT TEST** mode by following the specific procedure and carry out the loop preparation cycle until the loop loading cylinder is found in a fully extended position. The carriage is now at the limit stop; the head of the adjustment screw touches the block.

Check the position of the loop with respect to the needles, which should be about 1.5 mm inside the loop (image 1) and at the centre of the external pins.

If the position of the carriage must be adjusted forwards or backwards, loosen the limit stop screw (image 2) and adjust as necessary.

Adjust the position and height of sensor No. 8 in the stop position, the bar on the sensor must cover the right half of the sensor and be at a distance of about 0.2-0.5 mm.

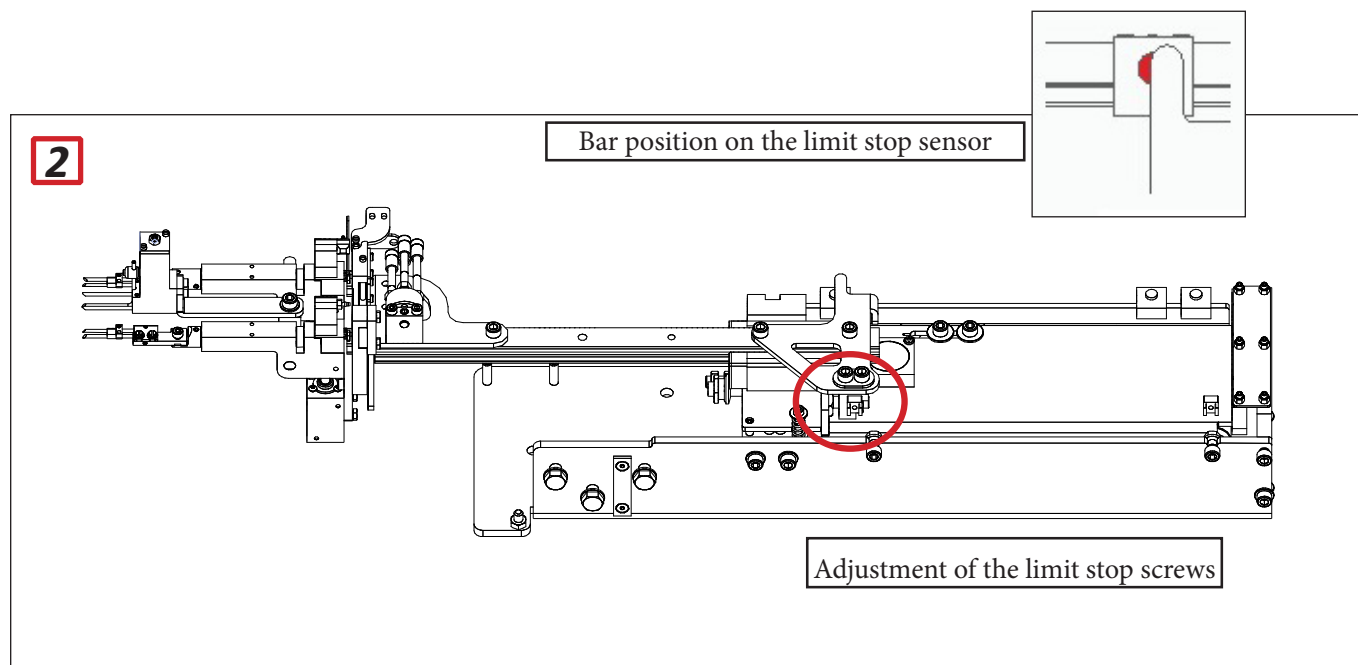
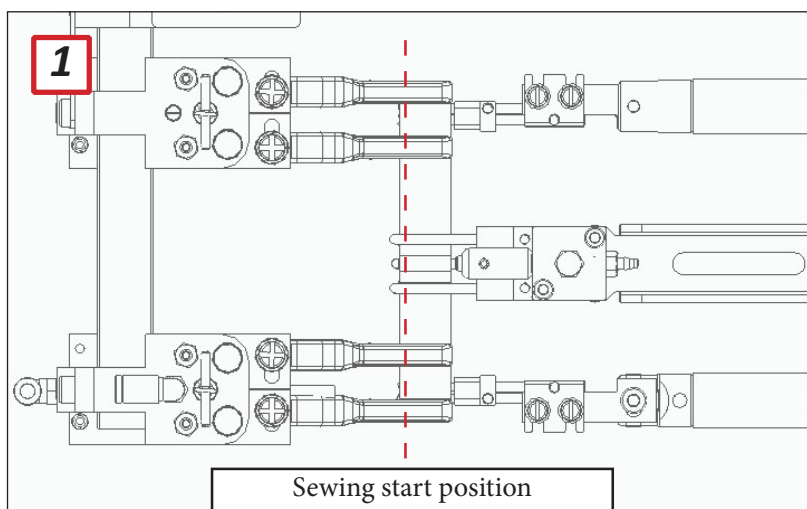

20.6- Adjustment of the loop carriage height under the feet

Call up the EQUIPMENT TEST mode by following the specific procedure and make the carriage move forward until it is found in an extended position; using the screw on the carriage (image 1) adjust the height as high as possible making sure that the loop does not touch the foot.

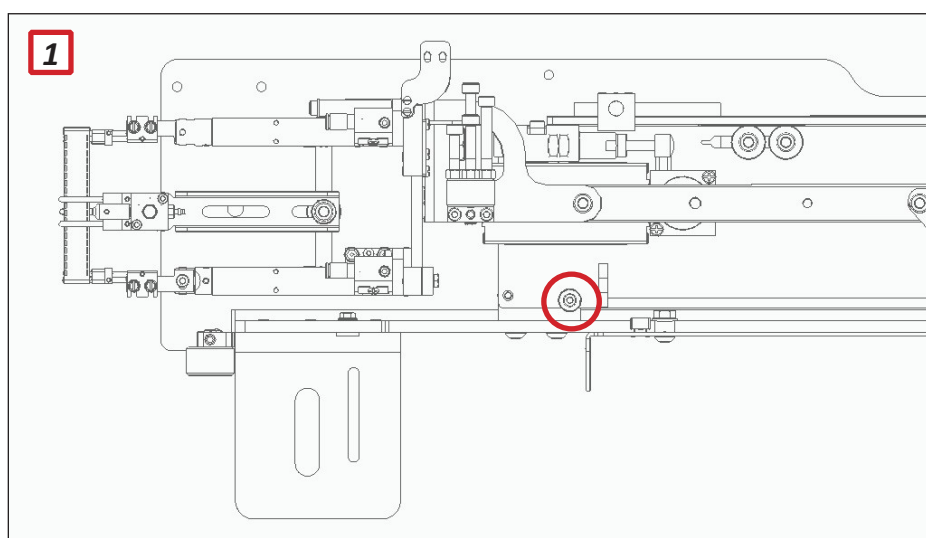
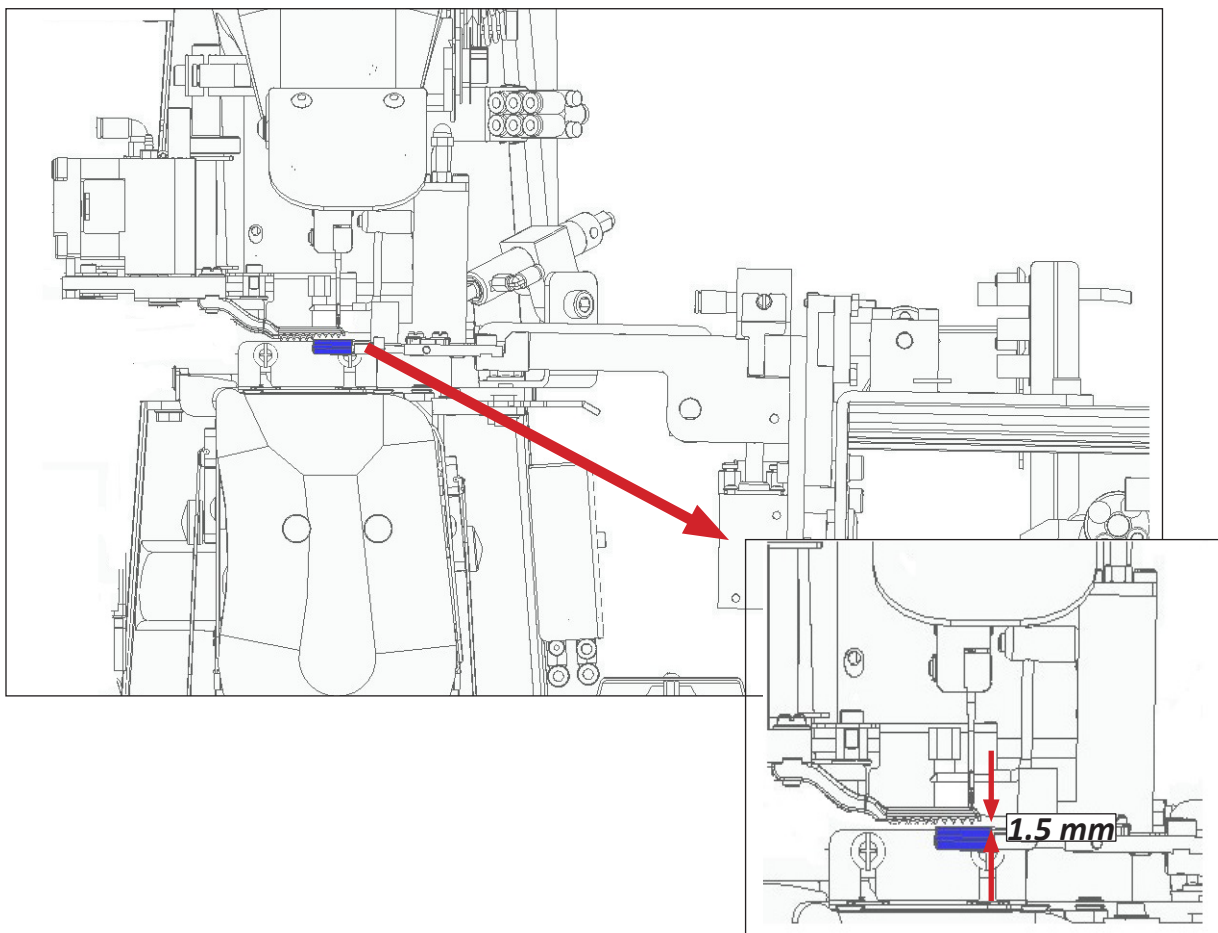

20.7- Carriage return speed adjustment



The pressure regulator needs to be used for this adjustment. (see image below)

- if the return speed is slow, adjust the pressure to 2,3 bar
- if the return speed is fast, adjust the pressure to 2 bar

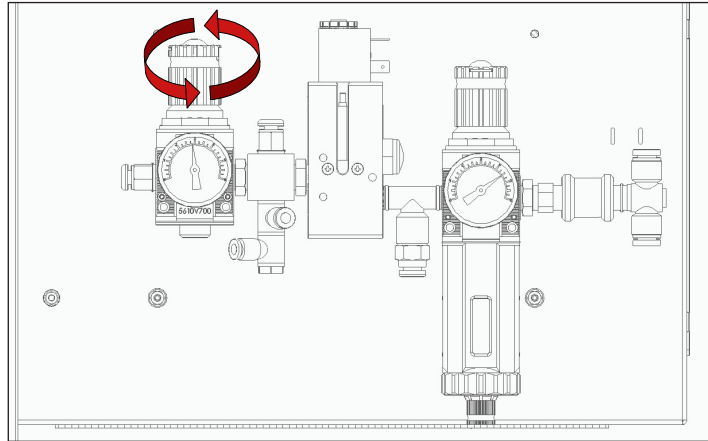

!CAUTION!

changing the air pressure too much will change the intermediate stop position

21. LOOP ALIGNER

The loop aligner corrects the loop position after loading and folding, and must be adjusted in correspondence with the length and width of the loop.

To adjust the width use the upper screws, and to adjust the length use the side screws.

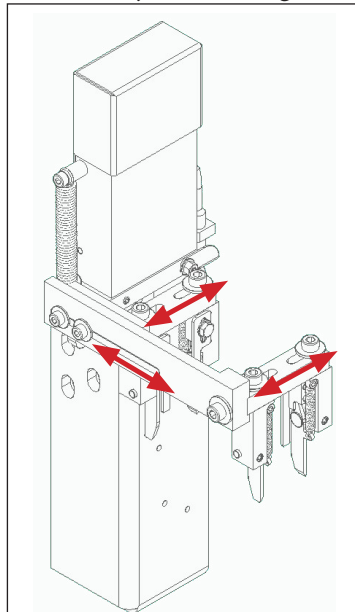

When the carriage is in the forking position and the loop aligner is lowered, the distance between the aligner and forking pins must be 1 mm.

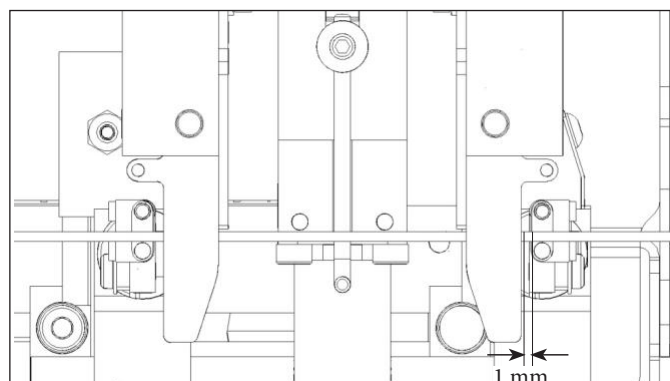

22. SEWING HEAD ADJUSTMENTS



CAUTION!

TURN THE UNIT OFF BEFORE MAKING ANY ADJUSTMENT

22.1- Adjustment of the rotary hook timing

The unit is equipped with two needles, with two large rotary hooks and uses a 134 SUK MR needle system as well as a single positioner for synchronizing the thread cutting system. Check that the adjustment of the hooks is exactly the same as when their tip is in the centre of the needle.

First check the height of the needle bar by placing it at the bottom dead centre; the eye of the needle must be 1/3 free at the top and the thread must be slightly clutched, and that it is 2/3 covered at the bottom by the needle guard.

Position the needle bar at the bottom dead centre point, the thread must be free to move inside the needle eye otherwise there may be slight friction.

To adjust the height of the needle bar loosen the screw that fastens the needle bar marked in the image below.

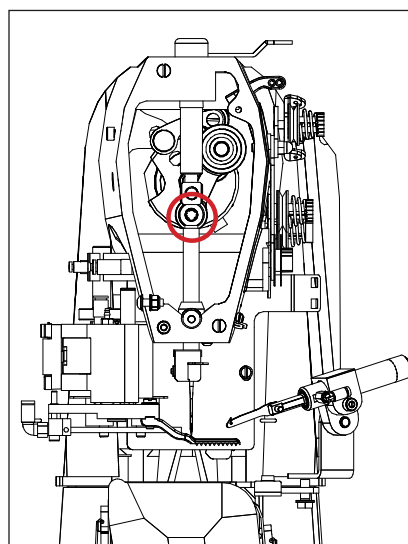
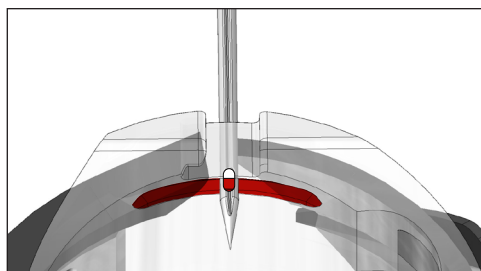

At this point, remove the bobbin from the basket case; rotate the pulley. Lifting the needle bar to 2.2 mm from the bottom dead centre point, the rotary hook tip must be at the centre of the needle at a distance of approximately 0.05 mm as per the image below. To adjust the rotary hook loosen the three screws marked in the image below.

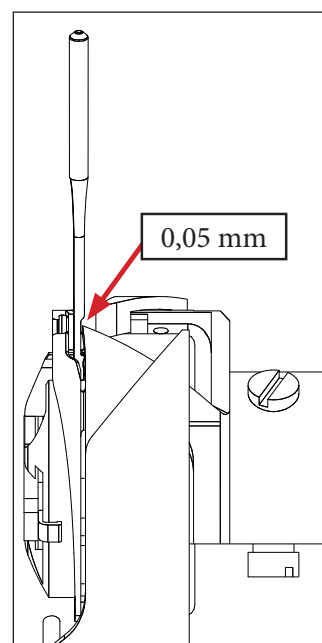
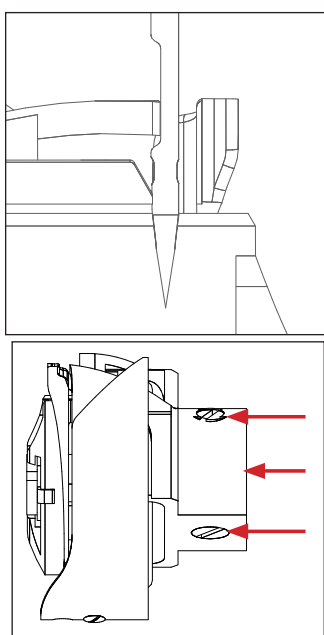



After having tightened the screw of the rotary hook, the basket retainer must be adjusted as per the image below so that the space between the basket retainer and the basket case is sufficient to let the thread pass through. (1-1.5 mm)

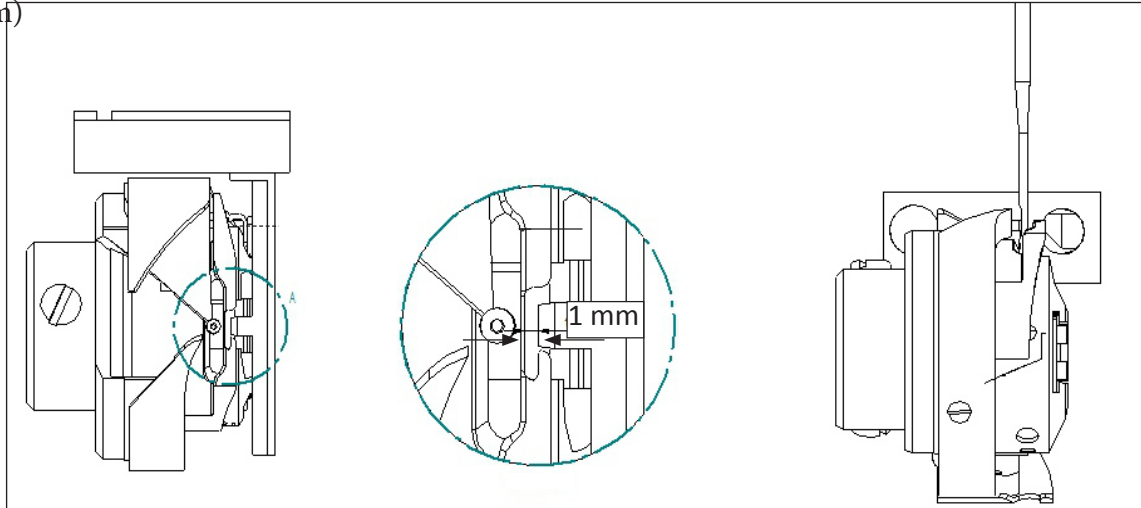

22.2- Adjusting the thread trimmer

The unit is equipped with a pneumatic thread trimmer. The entire thread cutting device is assembled on an adjustable support with two fixing screws. The height position is given by two calibrated screws, locked in the upper side. The block must always be pushed upwards so that the screws touch the lower part of the needle plate

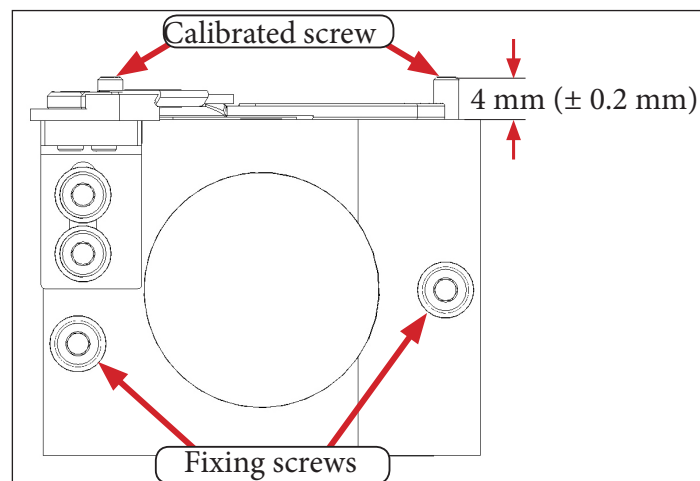

The movable knife is guided by a cylinder and must enter the triangle formed by the threads (image A). The correct position is that showed in image 1. The tip of the movable knife must be to the left of the needle tip, for the inner rotary hook and to the right of the needle tip, for the outer rotary hook. When the cylinder is in a maximum open position, the back side of the movable knife must pass the basket retainer by at least 1.5 mm (image 2).

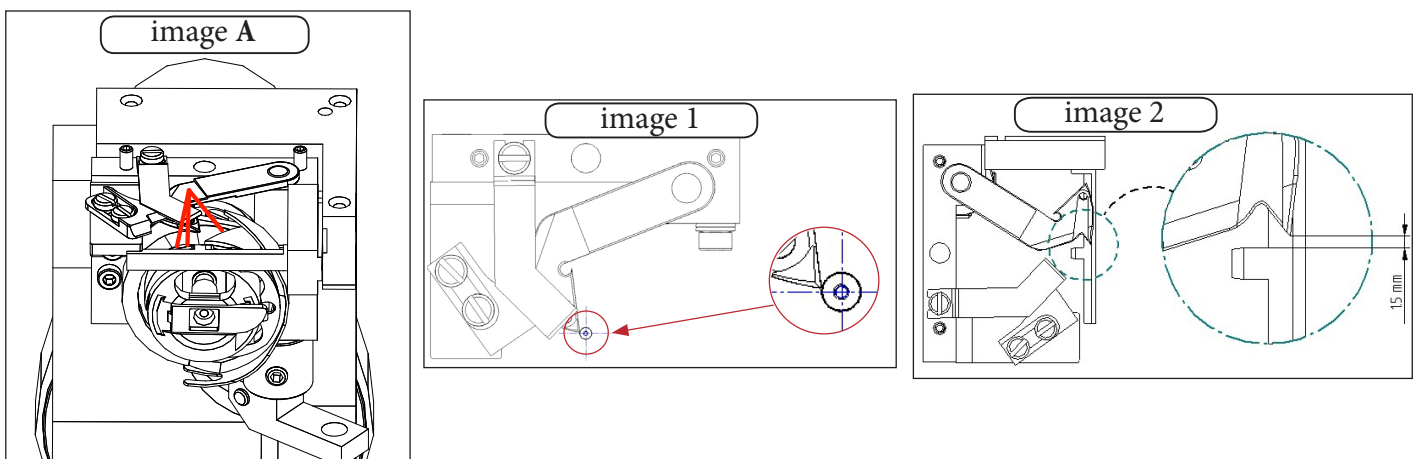

This measure is needed to ensure that both treads on the needle and the thread of the bobbin are correctly taken by the moving knife. Use the specific screw (picture 3) to adjust the position of the moving knife.

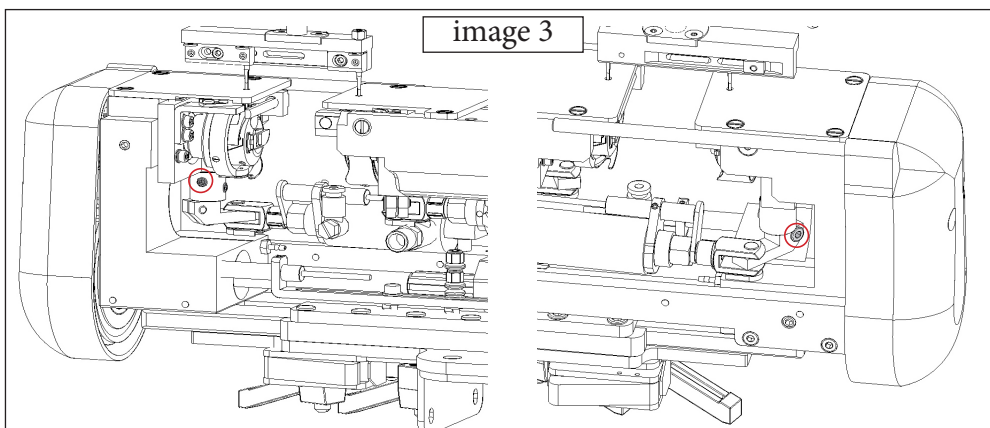

When adjusting the position of the moving knife, make sure that after the fixing screw are tight there is no play up and down (image 4), so that the movement of the moving knife is free and there is no clearance.

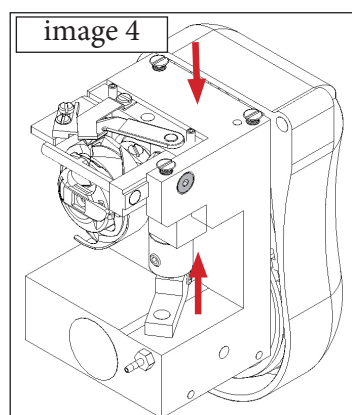

Check that the point of the fixed knife covers the hole in the movable knife by 1 mm and that the hole of the movable knife is covered by the fixed knife, when the stroke of the mobile knife is positioned in the maximum back.

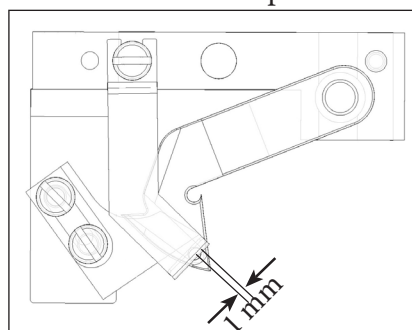
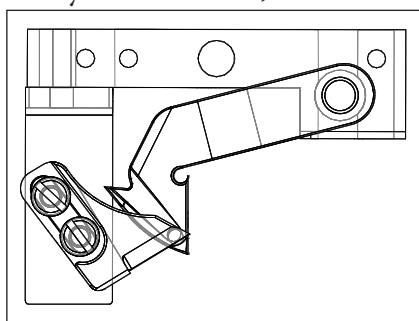

To adjust the flatness of the fixed knife, loosen the fixing screws (fig. 4). Pressure and flatness allow the knife to make correct cuts. Manually check that the knife cuts with as little pressure as possible. To check the flatness of the knife, it is necessary to:

Remove the upper spring of the thread trimmer.

Carry forward the movable knife and colour the upper side with a BLACK marker.

Bring the moving knife back, then check if the knife is fixed. Check that the colour is removed evenly from the contact surface. Perform a final cutting test, using 2-3 threads at the same time to make sure that the cut is correct.

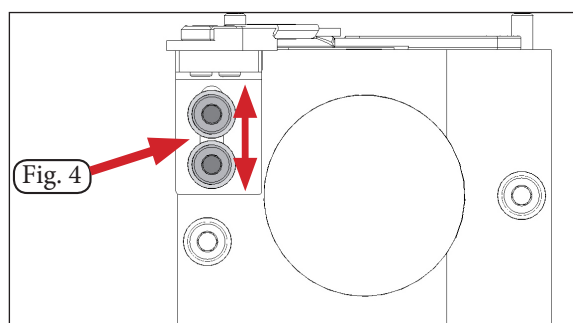

22.3- Adjusting the thread trimmer spring



On the knife support there is a spring positioned on the fixed knife. It is a safety component, to prevent the thread being pulled by the moving knife from being cut in advance by the fixed knife that could result in too short of a thread in the needle.

CAUTION:

Check that there are no scratches or chipping on the thread passing surface. Check that the compensating spring does not exert excessive pressure against the movable knife to avoid having to balance the alignment/flattening with the fixed knife. The spring arrangement can be seen in the image below:

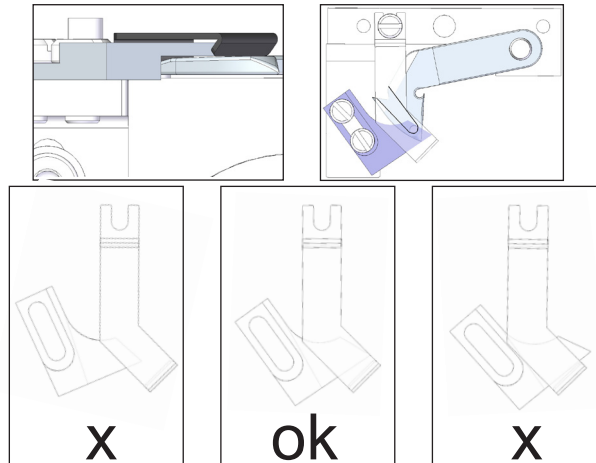

22.4- Adjustment of the movable knife closing regulator

The sewing head is equipped with a pneumatic thread trimmer and an electronic control operated by a MITSUBISHI control unit. The control unit, with the stop detector (UP signal) on the handwheel, calculates where the DOWN signal is located. The starting value of the moving knife is set with the “TS” parameter, while the return value of the moving knife is set with the “TE” parameter. The opening time in tension and return of the thread wiper is managed by parameter L2. The bigger the value the longer the opening time in tension. The return speed of the cylinders must be adjusted to the lowest possible level, so as to prevent the bobbin from making more turns during the stop.

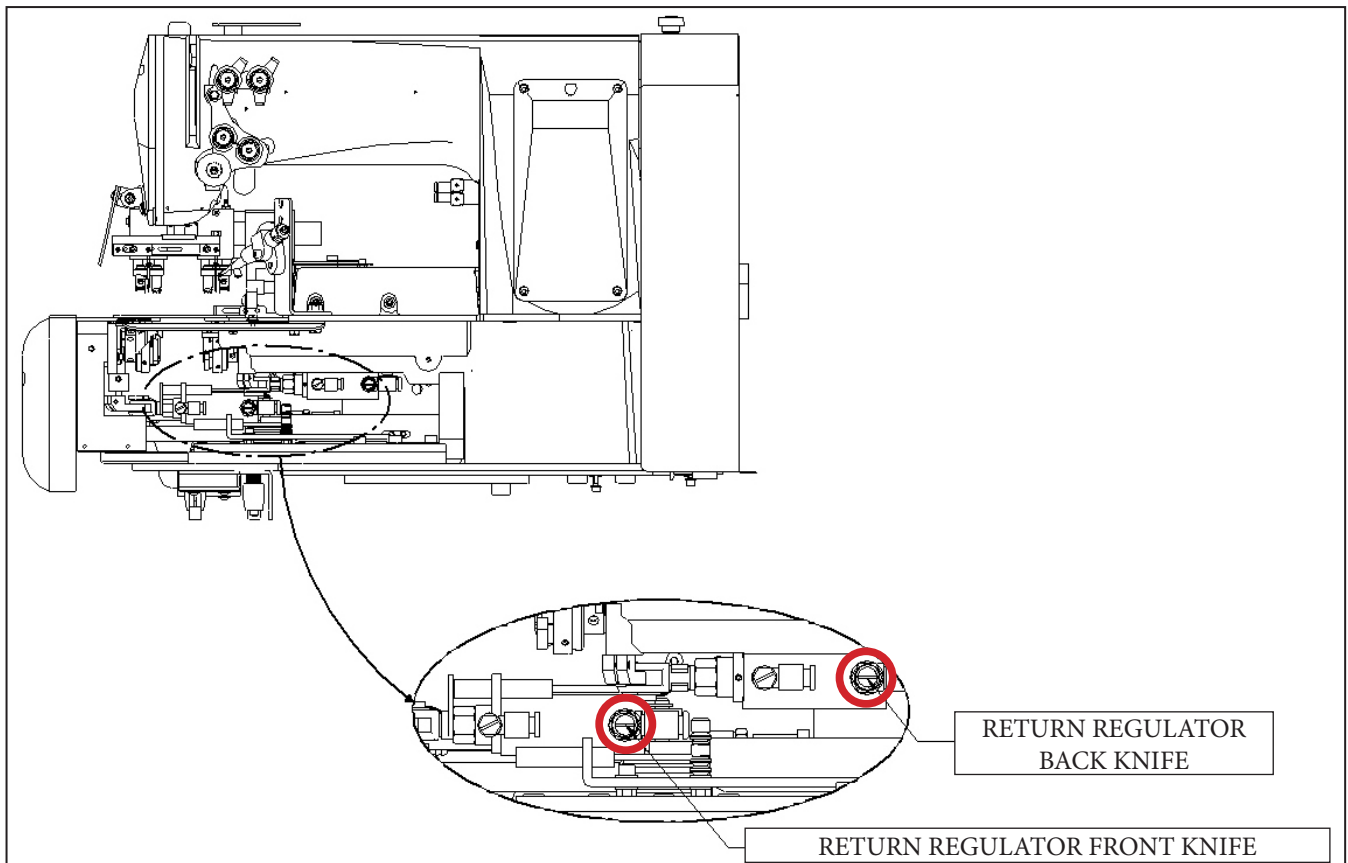

23. ADJUSTMENT OF THE PRESSER FOOT



The presser foot assembly is the device that holds the loop in place during sewing.

To ensure correct operation, check that the needle is in the centre of the foot and the seam is perfectly centred between the two parts of the presser foot, see image below

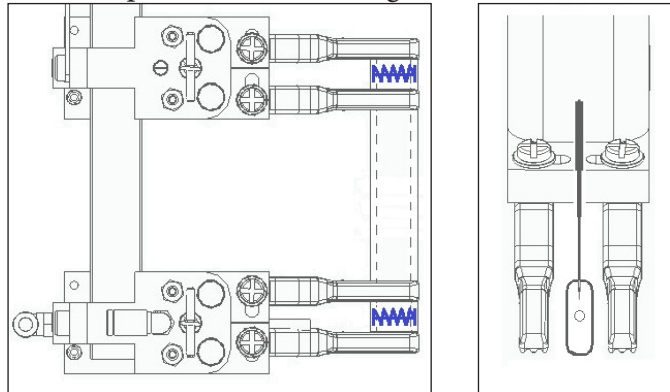

23.1- Longitudinal adjustment

To adjust the longitudinal position loosen the fixing screws on the presser foot support.

Move the presser foot support back or forward until the needle is in the middle of the presser foot

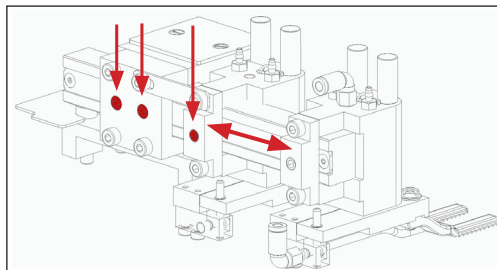

Check that the needle does not touch the presser foot during the sewing cycle; in case of adjustments, loosen the screw that fixes the presser foots, position as desired and tighten the screw again.

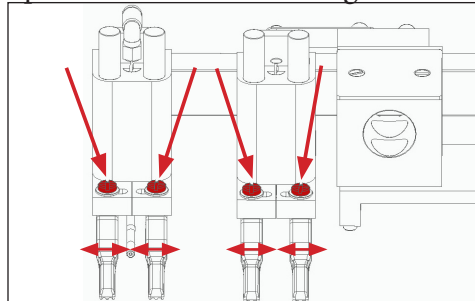

23.2- Left-right position adjustment

The left-right position of the presser foot is automatically adjusted when the length of the bar-tacking stitch is changed. If small adjustments are necessary on the left-right position, simply adjust the position of the sensor on the X-axis motor, shown below.

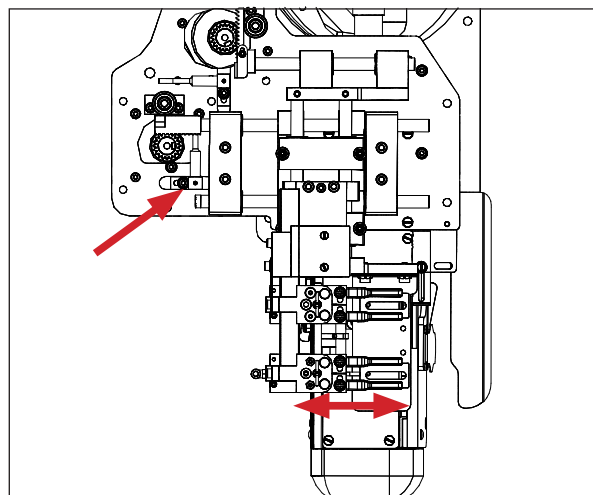

23.3- Positioning of the presser foot



The purpose of the presser foots is to keep the loop firm, even if the shape of material have different thickness, like the back yoke of the trouser. The presser foot must be positioned so that it rises up on the profile of the material to block the material by at least 1.5 mm. The compensating presser foots have to be parallel to the foot body, adjust the position with the fixing screw.

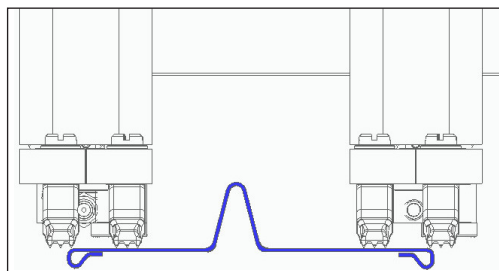

For better positioning of the presser foots on the loop and to avoid vertical play, check that the compensating knob is well fixed on the block of the presser foot. The knob must touch the entire surface and the block must slide slightly. To adjust the pressure knob, loosen the screw marked in the image below.

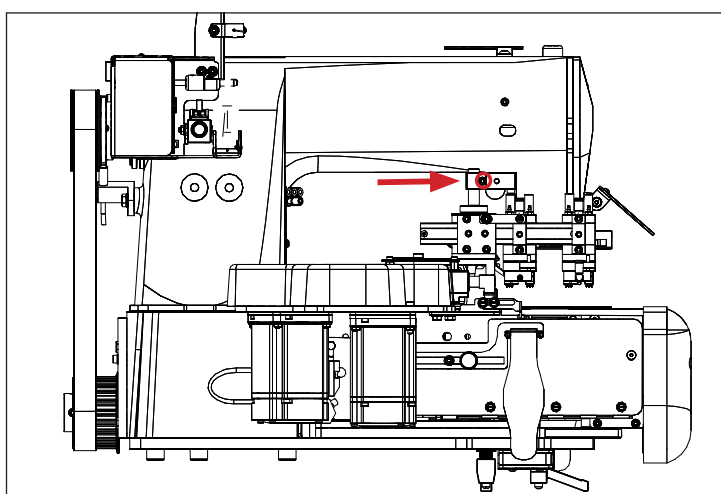

24. FUNCTIONING OF THE THREAD CATCHER

The unit is equipped with a thread catcher for the internal needle with a double effect piston that takes the thread after the thread trimmer has finished moving. This thread catcher works together with the thread tension, and keeps the thread upwards so that it is not blocked by the trousers. This device gives a clean stitching..

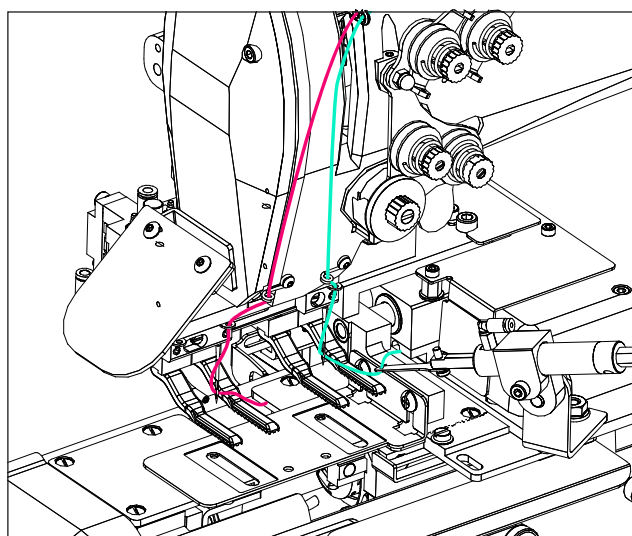

If the operator wants to use the thread blower on the other foot, a tube can be attached on the T-connector found on the 4 mm yellow tube.

25. CHANGING THE SIZES OF THE LOOP



The 4650EV9@UP2 unit can sew loops with different lengths and widths. The width is between a minimum of 8 mm to a maximum of 28 mm, while the length is between a minimum of 32 mm to a maximum of 85 mm. The unit is equipped with a quick change system to obtain the desired loop size.

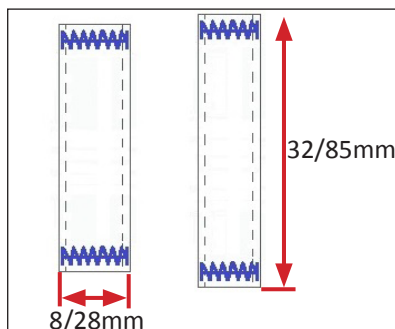

To change the length of the loop, proceed by changing the distance between the needles and the loop pulling and loading assembly. The position of the internal needle, presser foot together with the internal forking pin remains fixed and only the external needle, external foot and the external forking pin must be moved, follow the operations explained below.

25.1- Changing the length of the loop

25.1.1- Replacement of the transport plate

To change the length, change the feeding plate with the hole made to the desired size, loosen the 2 screws that hold the feeding plate and replace it with another of the desired size.

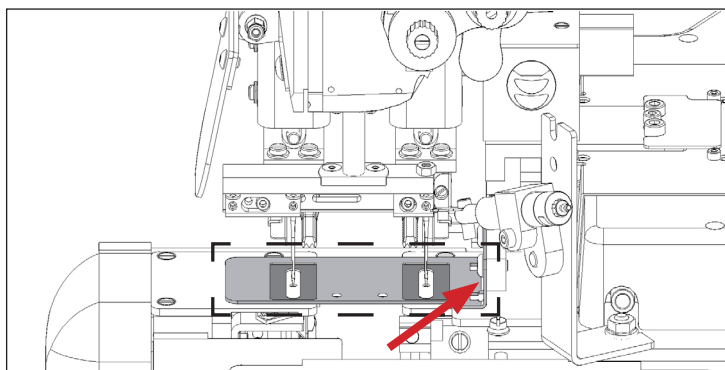

25.1.2- Positioning the external head

By loosening the attachment knobs of the added head (image 1), it is possible to slide it forward or backward until the eye of the needle is in the centre of the feeding plate. Then rotate the gauge drum (image 2) until one of the screws is at the desired distance. When completed, make sure to tighten the fixing knobs of the additional head. There is an additional head sensor that prevents the sewing unit from detecting its presence. Adjust this sensor (image 3) so that the end rests against the additional head.

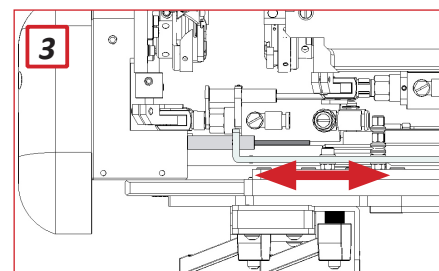
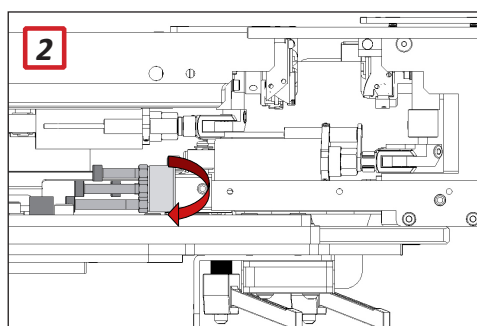
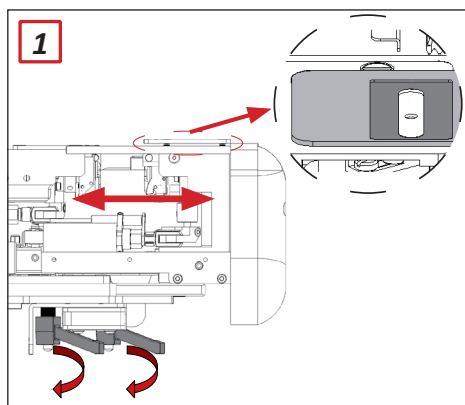

25.1.3- External needle clamp position



To change the distance between the two stitches, change the position of the external needle with his clamp. Loosen the fixing screw of the external needle clamp and move it towards the external head. Check the exact distance between the needles, using a caliber, and check that the needle is perfectly centred with respect to the needle plate hole and the position of the external rotary hook (see image below)

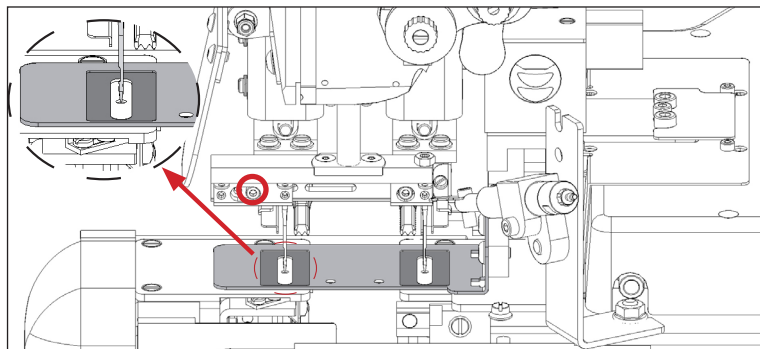

25.1.4- Position of the external foot

Loosen the 3 fixing screws on the presser foot support (image 1). Position the presser foot by moving the entire support towards the needle position. Fasten the 3 fixing screws on the foot support when the position is defined.

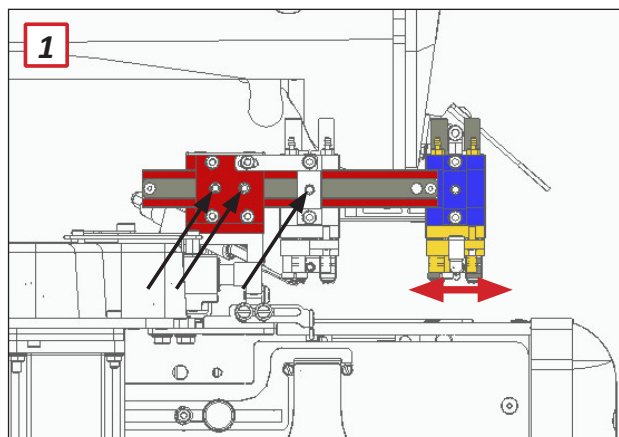

25.1.5- Adjustment of the forking pins device distance

The distance between the loop forking pins device must be 3-4 mm bigger than the distance between the needles. This is adjusted by moving the external pins assembly (indicated with B) forwards or backwards and the internal pins assembly (indicated with A) is fixed, it has only a maximum adjustment margin of 5 mm when changing fabrics with a different thickness. To move the pins assembly B you must loosen the fastening screw marked in image 2, and then you have to loosen the screw 1 that fixes the positioning shaft of the two forking pins device assemblies. Move the forking pins device unit to the desired position and remember to fasten the screws.

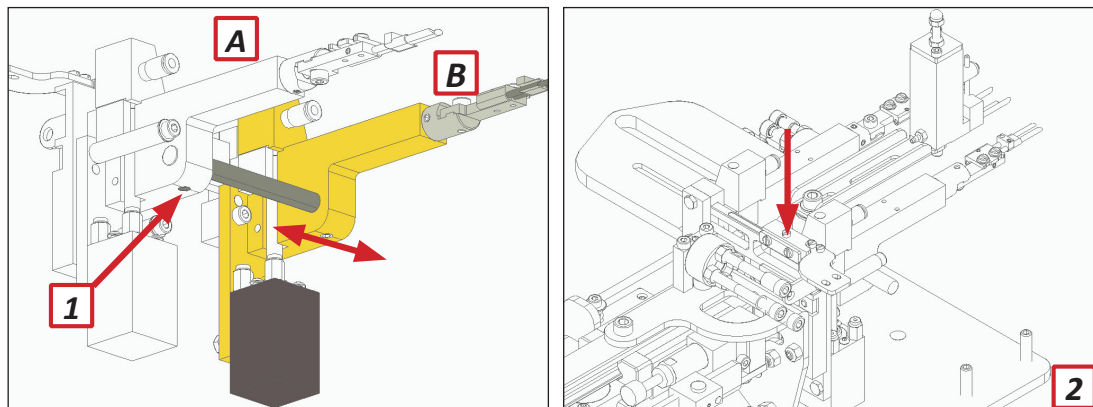

25.1.6- *Adjustment of the loop cutting assembly position*



After the position of the forking pins device assembly is fixed, the loop cutting assembly position must be adjusted. To make this adjustment follow the instructions explained in chapter 18.1.

25.1.7- *Adjustment of the loop pulling cylinder*

After the position of the loop cutting unit is fixed, the position of the loop pulling unit must be adjusted. Adjustments must be made as explained in chapters 19.1 and 19.2.

The turned-up part under the loop can have a minimum size of 5-7 mm. maximum.

25.1.8- *Adjustment of the loop aligner*

To adjust the straightener only the external part must be moved, loosen the screws marked in the image and adjust as necessary according to the new loop to be made. The inner part remains fastened.

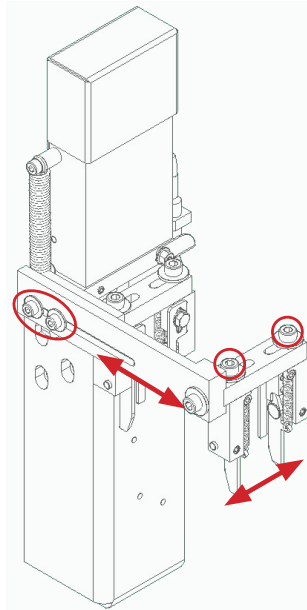

25.2- *Changing the width of the loop*

To change the width of the bartack a new sewing program must be created with the value of the width set as desired, and the presser foot automatically move to the right if the width increases or to the left if the width decreases.

The mechanical adjustments required when the width of the loop is changed are explained in chapters 18.2, 20.2 and 20.3.

26. CLEANING AND MAINTENANCE



Every morning, before starting production, apply “SAE 100” oil on the marked points (figure 1). Clean the machine at least once a day to remove dust from the sewing mechanisms

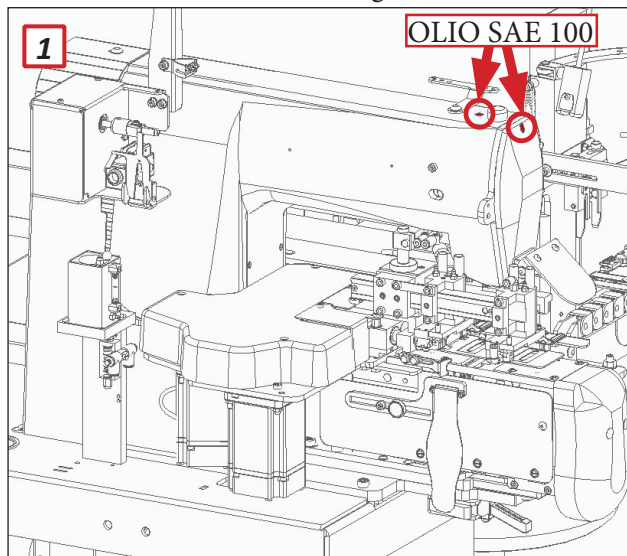

26.1- Lubrication of the rotary hook

However, for the hook use “VLOCITE 10” oil and adjust the amount of oil by rotating the fitting regulator (figure 2). The right dosage is when the oil tank/package is used up in 2 to 3 working days

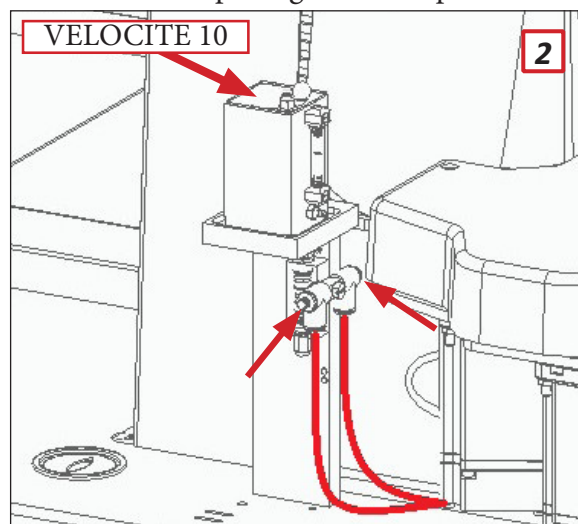

26.2- Lubrication and maintenance of the needle bar

Once a month, the needle bar cover should be opened, the dust found be removed with an air gun, and a little oil to be applied on the needle bar.

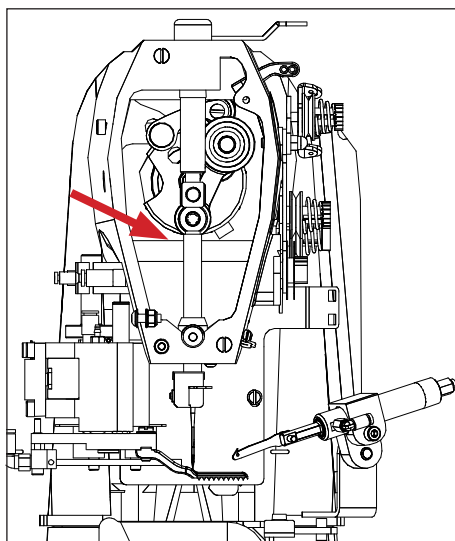

26.3- Maintenance of the X and Y axis



The X and Y axis is moved through a gear and a rack. It is important that the gear and rack are clean and greased at least once a month. Check that there is no clearance between the gear and the rack. This can be adjusted by placing the bearing behind the rack.

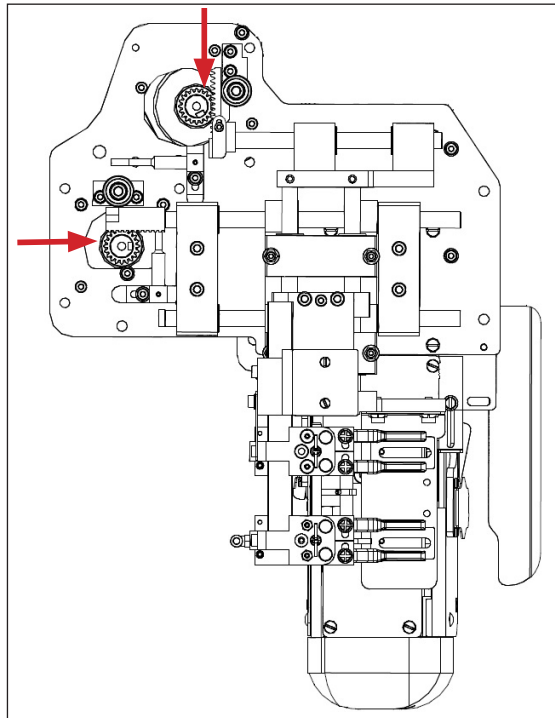

CAUTION!
GREASE ONLY THE X and Y MECHANISMS

27. TROUBLESHOOTING

Thanks to the experience gained over the years we can list a series of common failures with the related suggestions to try to solve them.

CAUTION: Always check if there are MESSAGES or ERRORS displayed on the screen of the Panel found on the unit.

For non-common faults or faults due to exceptional events, please contact the retailer who sold the unit, which in turn may request additional information:

CUSTOMER CARE OFFICE
VI.BE.MAC. S.p.A.
Via Monte Pastello 7/ I
37047 S.GIOVANNI LUPATOTO (VR)
Tel. +39 045 8778151
Fax +39 045 8779024

Email: customercare@vbm-grp.com

27.1- Control panel

The control panel is equipped with software made by Vi.Be.Mac that self-diagnoses itself by checking the status of the outputs and the inputs. If an error is found an error message will be shown automatically. The main problems with the following solutions are listed below:

PROBLEM:

The panel does not turn on and the screen is always black

Solution:

- Check that the 4-pin power board is inserted into the panel connector.
- Check that the F6 fuse is not burned out.

PROBLEM:

The panel does not light up and different colours appear on the screen for more than 4 minutes

Solution:

- Check that the CB 27 cable is connected to the panel and to the CPU board and that it is not interrupted in order to guarantee communication between the 2 components. If the problem persists, there could be a problem on the CPU board.

PROBLEM:

The panel's touch screen does not respond

Solution:

- Check that there is no dust on/under the protective film, and remove it carefully
- Also check that the metal casing is not bent and does not touch the display.

PROBLEM:

The technical parameters are not enabled when the key is turned.

Solution:

- Check the key's rotary movement. If no mechanical problems are detected, contact an authorised technician to replace the key lock.

Contact the regional customer care office for any other problems with the panel.

IT IS IMPORTANT TO KNOW THAT THE UNIT WORKS EVEN WITHOUT THE PANEL AND MUST NOT BE CHANGED ONCE THE SEWING HAS BEEN SELECTED.



CAUTION!

THE UNIT MUST BE TURNED OFF TO REMOVE THE PANEL

28. ELECTRIC DIAGRAM

Electrical diagram 4650EV9@UP2



Vi.Be.Mac.

V 1.2

Title	4650EV9@UP2
Author	Campedelli Luca Vi.Be.Mac.
File	Electric_Diagram_4650EV9_UP2_V1.2_ENG.dsn
Revision	1.2
Date	13/12/2017
Document	
Sheets	1

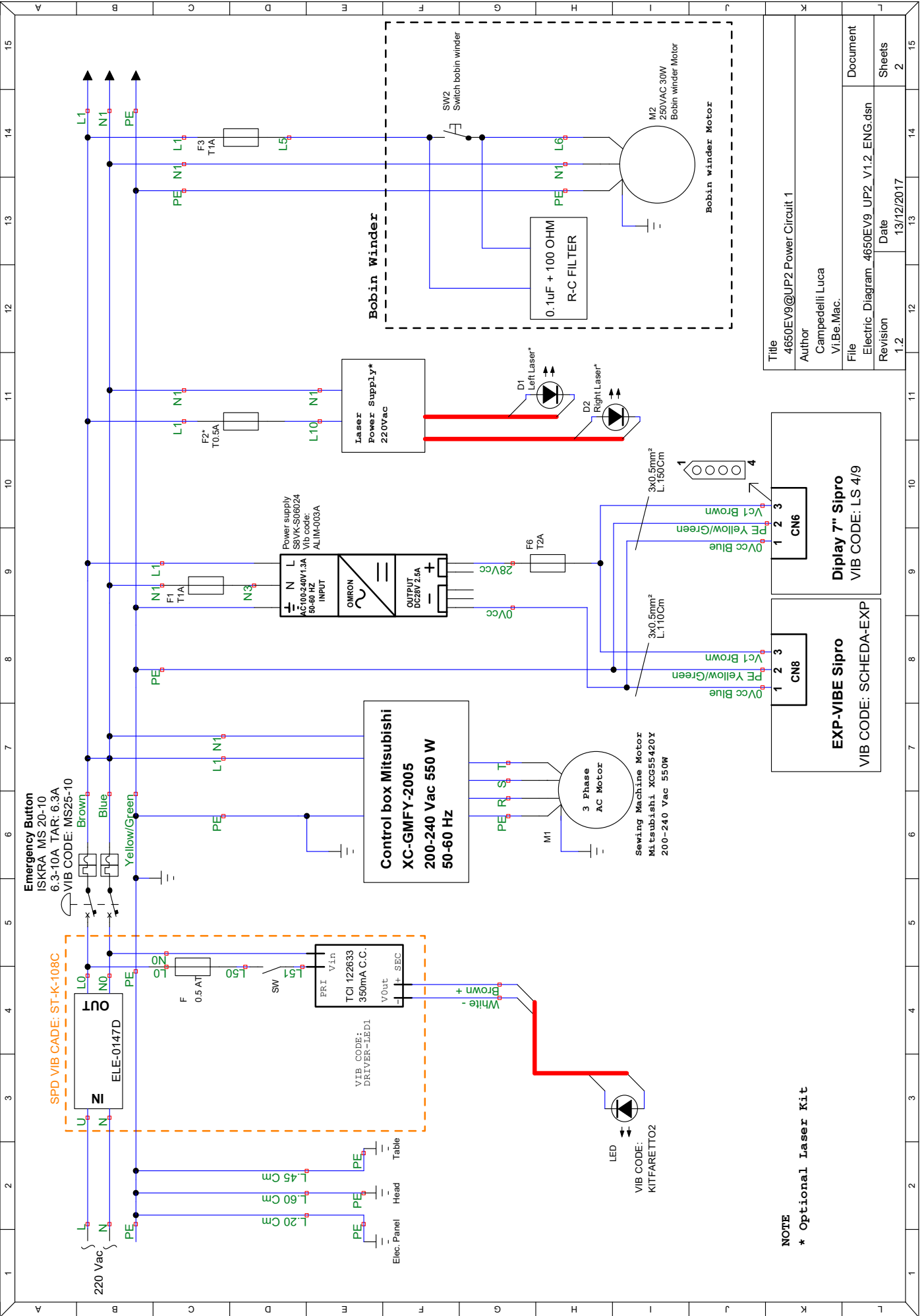

Title	4650EV9@UP2 Power Circuit 1
Author	Campedelli Luca
File	Vi.Be.Mac.
Revision	1.2
Date	13/12/2017
Document	Electric Diagram_4650EV9_UP2_V1.2_ENG.dsn
Sheets	2

EXP-VIBE Sipro	VIB CODE: SCHEDA+EXP
Display 7" Sipro	VIB CODE: LS 4/9

NOTE
* Optional Laser Kit

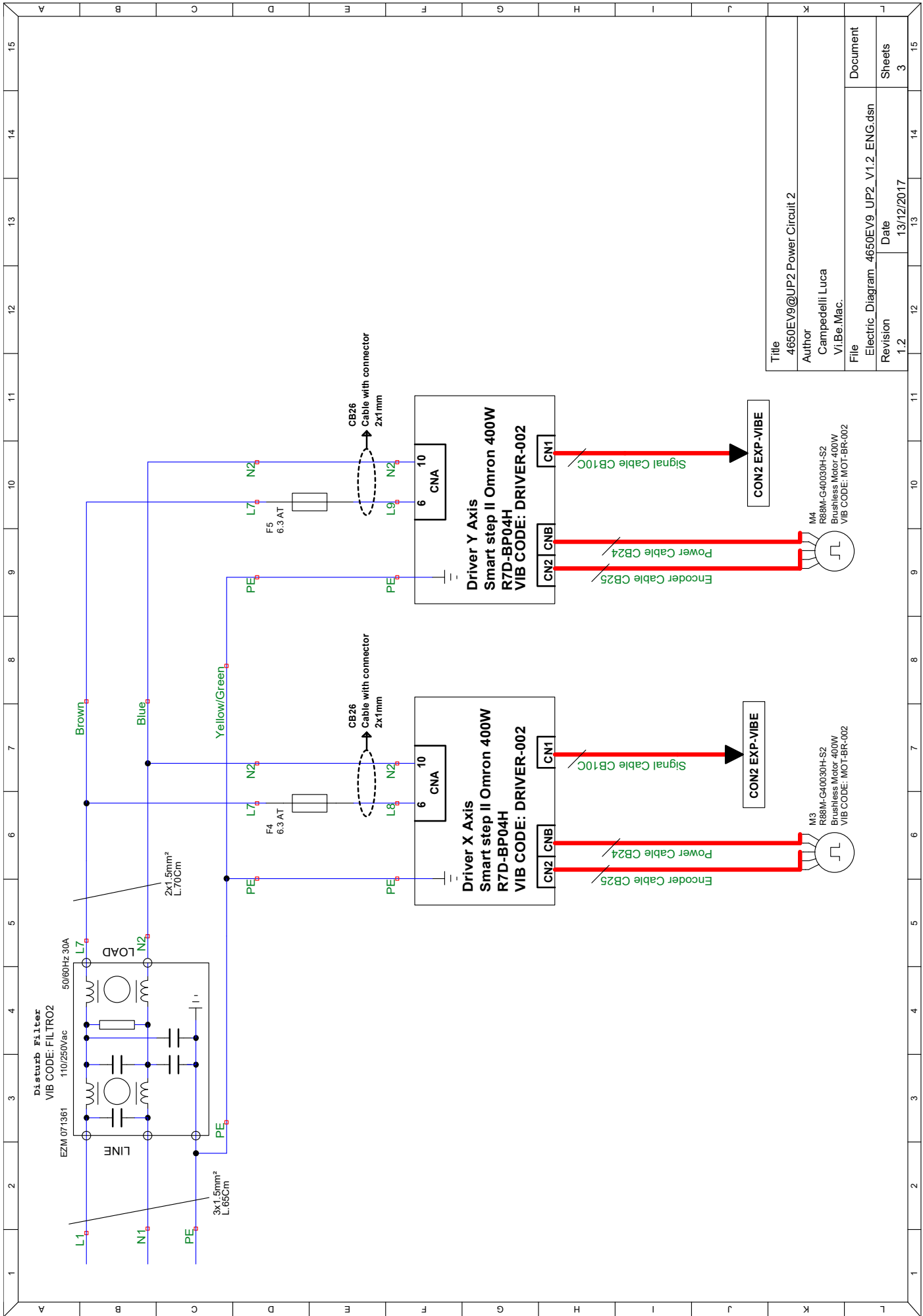

Title		4650EV9@UP2 Power Circuit 2	
Author		Campedelli Luca	
File		Electric Diagram_4650EV9_UP2_V1.2_ENG.dsn	
Revision	Date	1.2	13/12/2017
Document		Sheets 3	

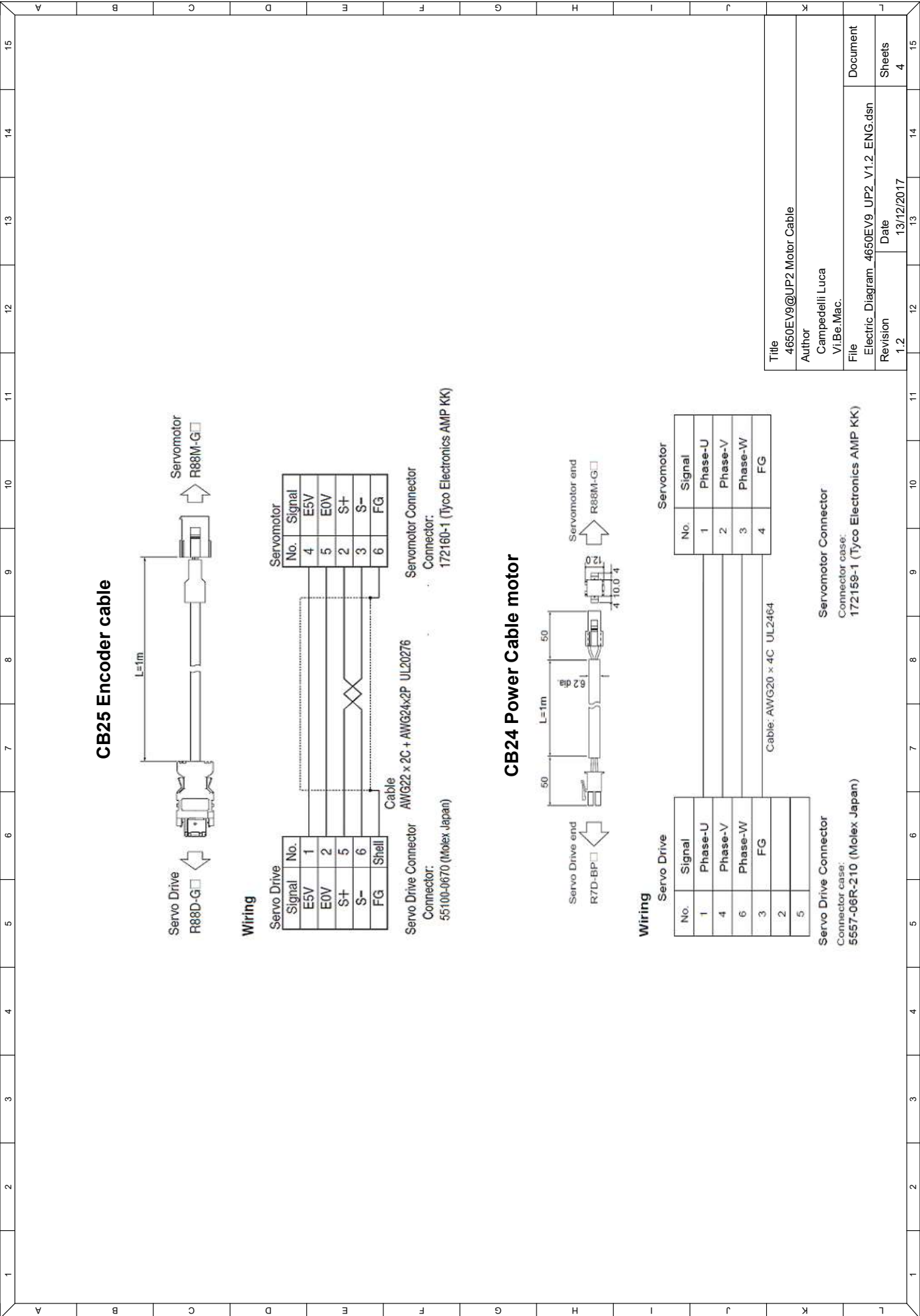

CB24 Power Cable motor

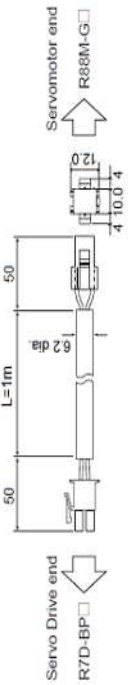

Wiring

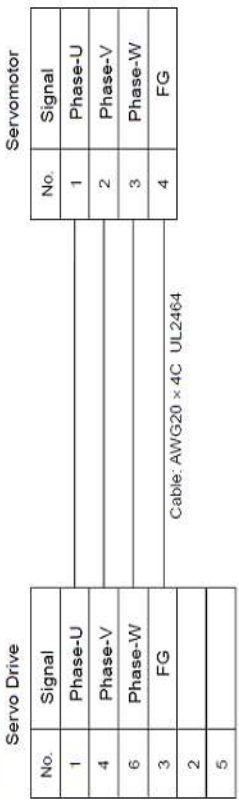

Title		4650EV9@UP2 Motor Cable	
Author		Campedelli Luca	
File		Electric Diagram_4650EV9_UP2_V1.2_ENG.dsn	
Revision	Date	1.2	13/12/2017
Document	Sheets	4	4

Connection of CB8C cable between CN1 of EXP-VIBE Board and Mitsubishi control box

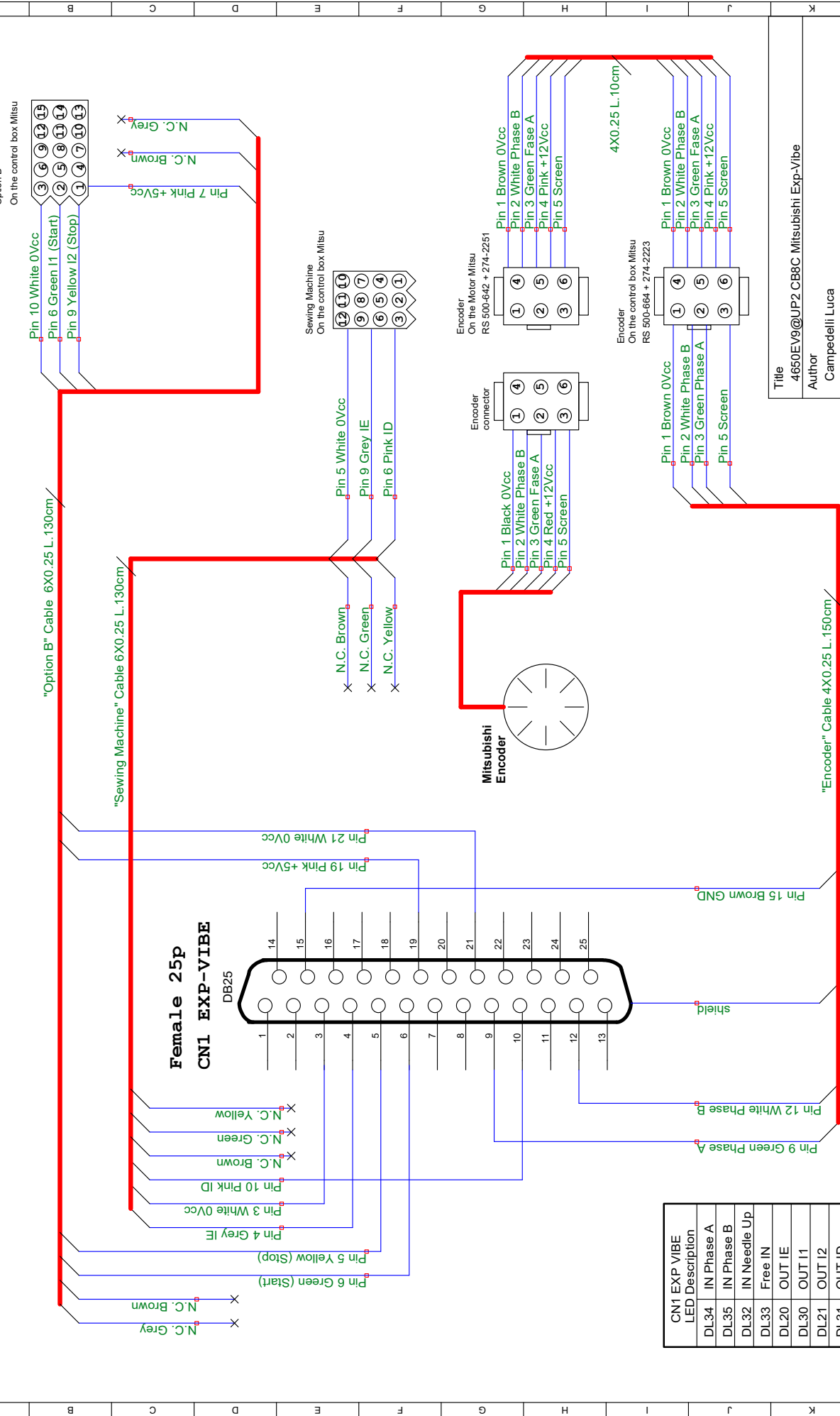

CN1 EXP VIBE	LED Description
DL34	IN Phase A
DL35	IN Phase B
DL32	IN Needle Up
DL33	Free IN
DL20	OUT IE
DL30	OUT I1
DL21	OUT I2
DL31	OUT ID

Title	4650EV9@UP2 CB8C Mitsubishi Exp-Vibe
Author	Campedelli Luca
File	Vi.Be.Mac.
Revision	1.2
Date	13/12/2017
Document	Electric Diagram_4650EV9_UP2_V1.2_ENG.dsn
Sheets	5

Connection of CB10C cable between CN2 of EXP-VIBE board and Omron Drivers

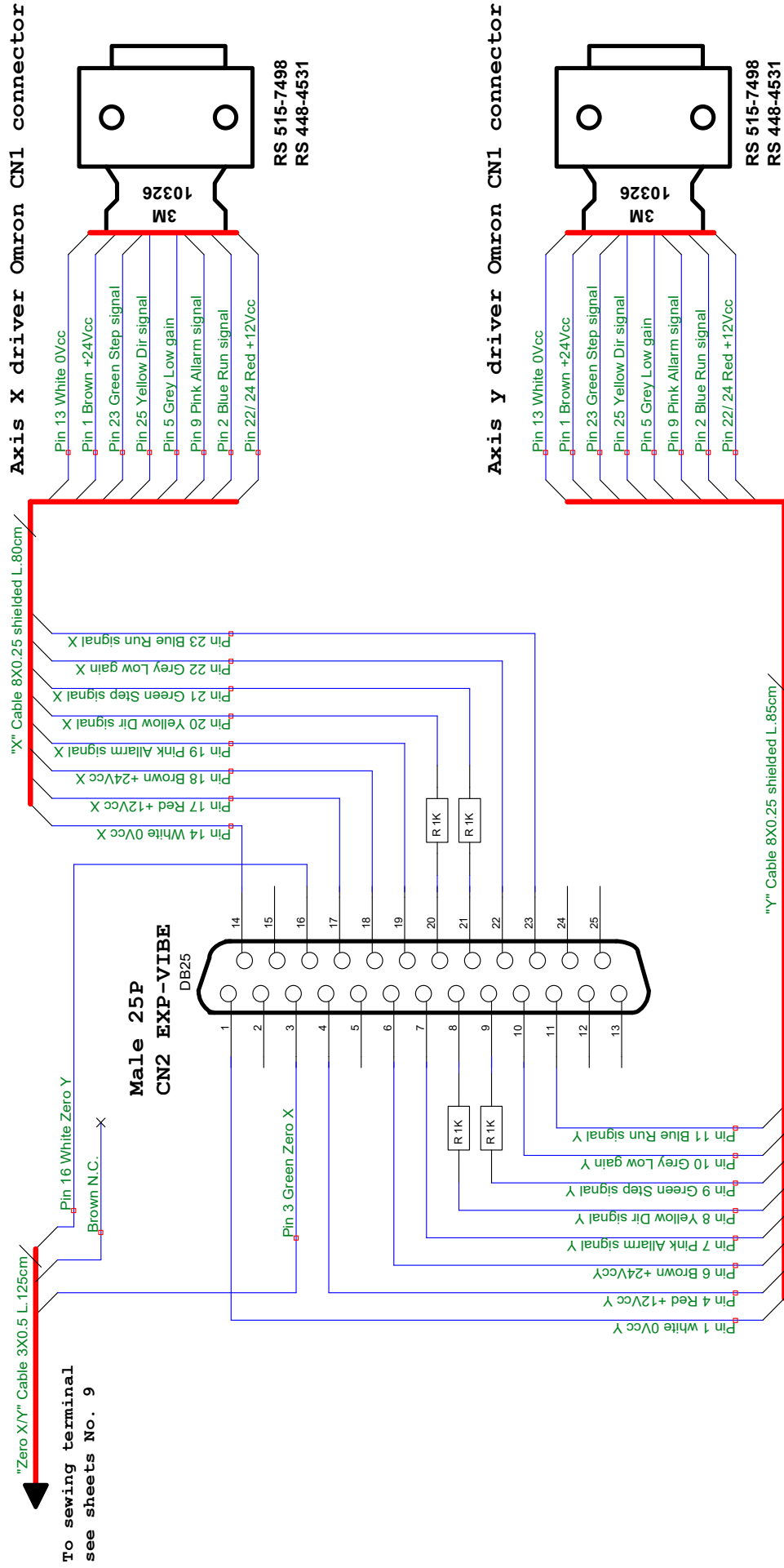

To sewing terminal see sheets No. 9

Title	4650EV9@UP2 CB10C Driver Exp-Vibe
Author	Campedelli Luca
File	Electric Diagram_4650EV9_UP2_V1.2_ENG.dsn
Revision	1.2
Date	13/12/2017
Document	Sheets
	6

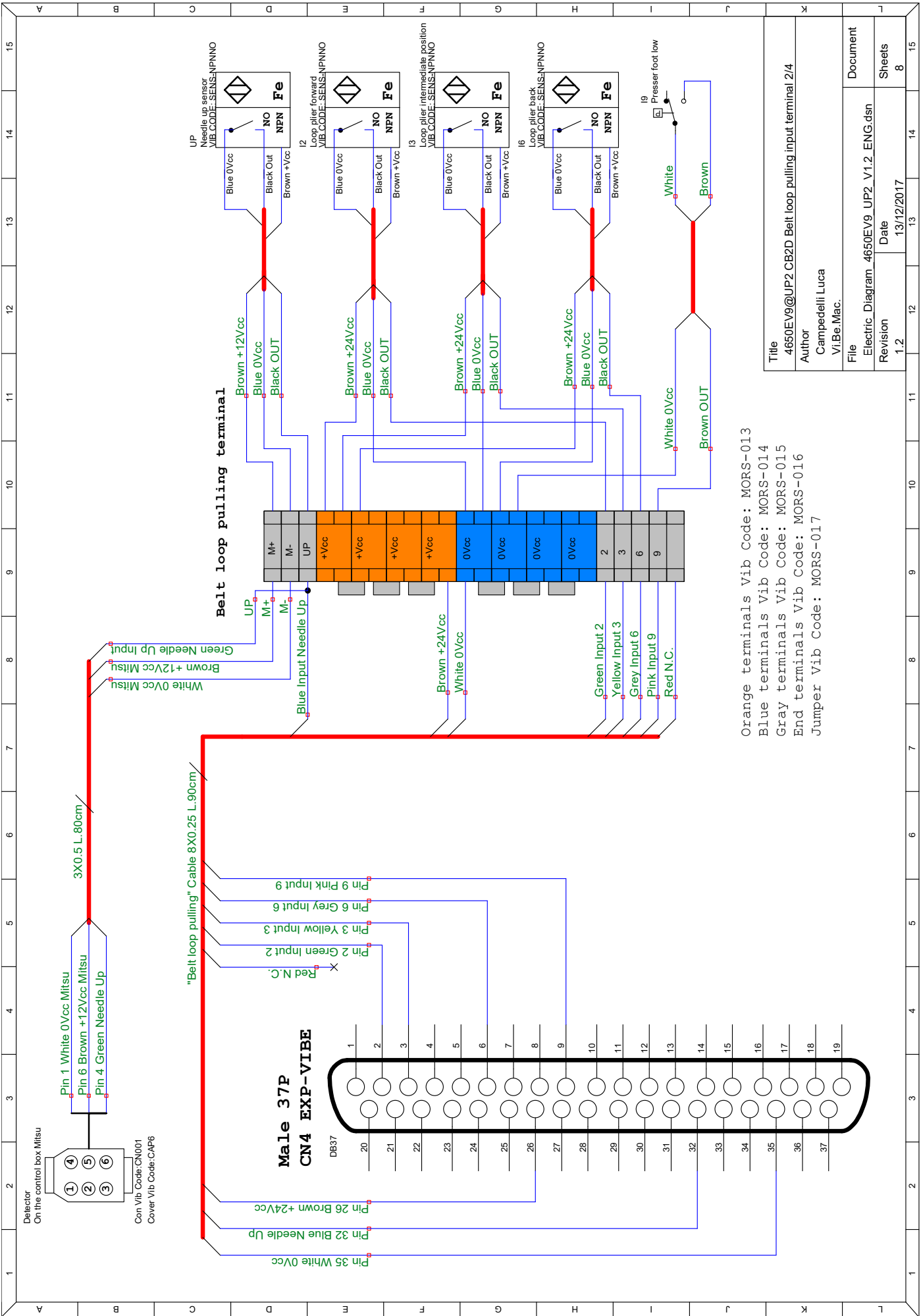

Title	4650EV9@UP2 CB2D Belt loop pulling input terminal 2/4
Author	Campedelli Luca Vi.Be.Mac.
File	Electric Diagram_4650EV9_UP2_V1.2_ENG.dsn
Revision	1.2
Date	13/12/2017
Document	8
Sheets	8

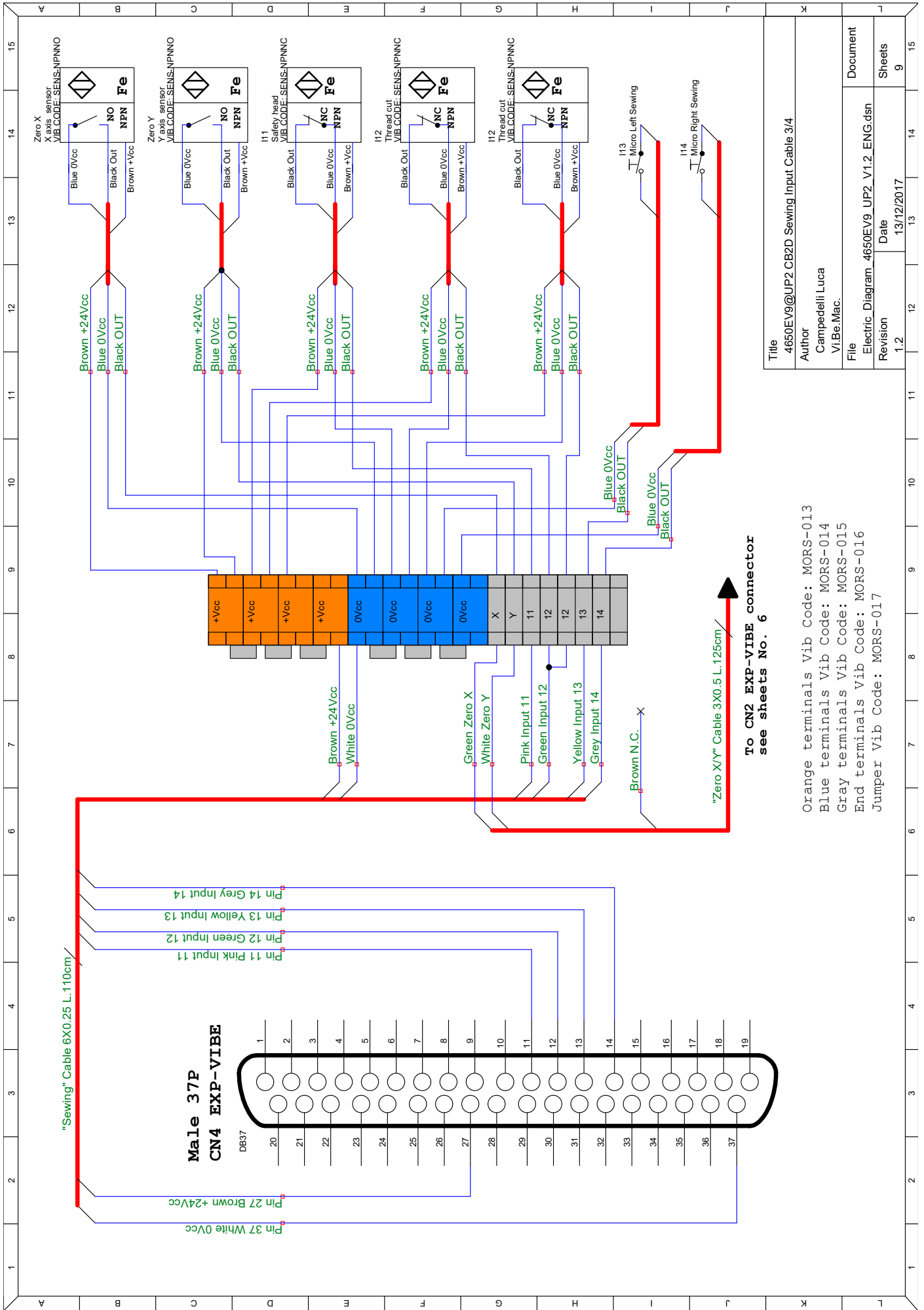

Title	4650EV9@UP2 CB2D Sewing Input Cable 3/4
Author	Campedelli Luca Vi.Be.Mac.
File	Electric Diagram 4650EV9_UP2_V1.2_ENG.dsn
Revision	1.2
Date	13/12/2017
Document	9
Sheets	9

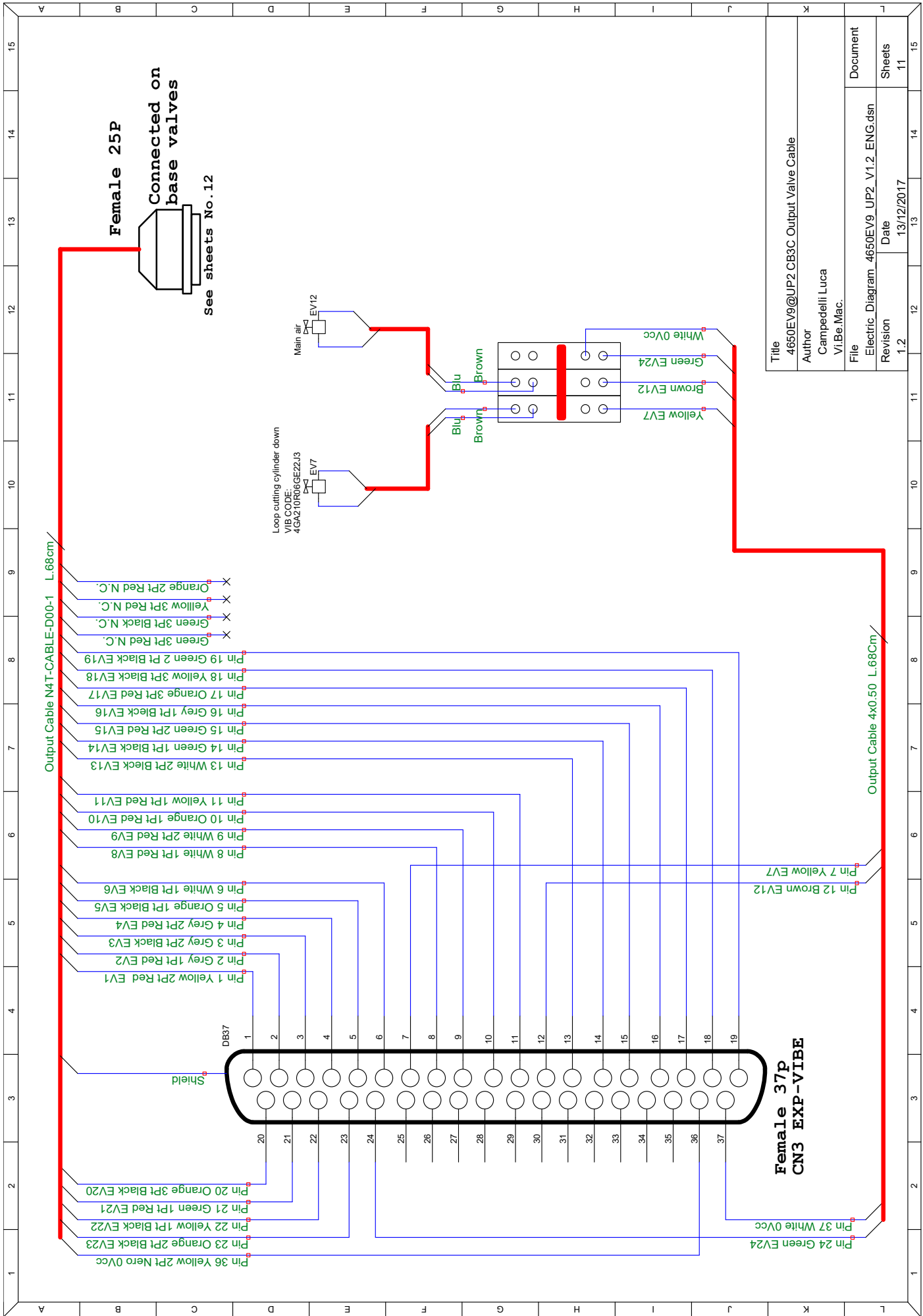

Title	4650EV9@UP2_CB3C Output Valve Cable
Author	Campedelli Luca Vi.Be.Mac.
File	Electric Diagram_4650EV9_UP2_V1.2_ENG.dsn
Revision	1.2
Date	13/12/2017
Document	11
Sheets	11

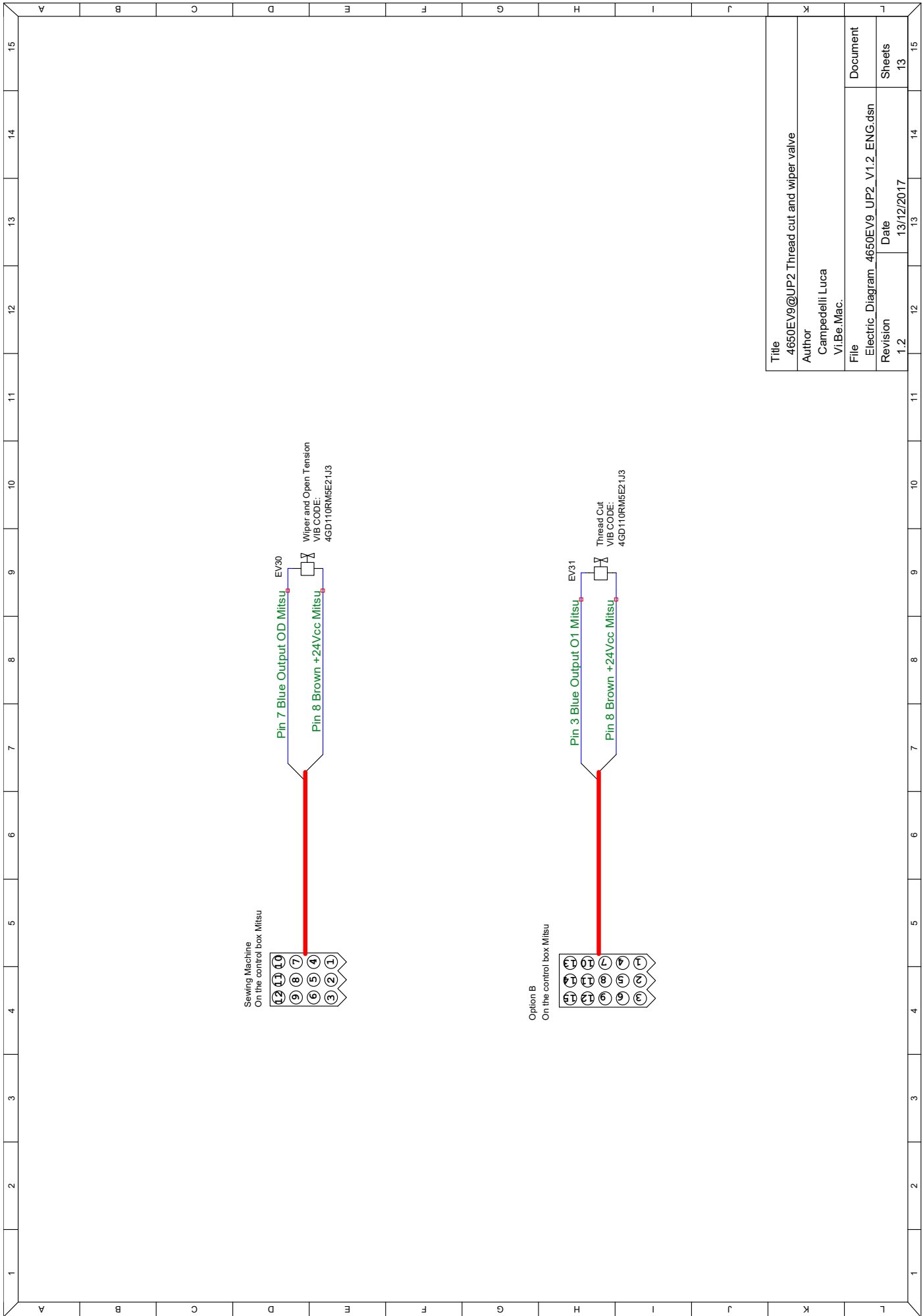

Title	4650EV9@UP2 Thread cut and wiper valve		
Author	Campedelli Luca		
File	Vi.Be.Mac.		
Revision	1.2	Date	13/12/2017
Document	Electric Diagram_4650EV9_UP2_V1.2_ENG.dsn	Revision	1.2
Sheets	13	Date	13/12/2017
			13
			14
			15

Topographical Arrangement 4650EV9_UP2

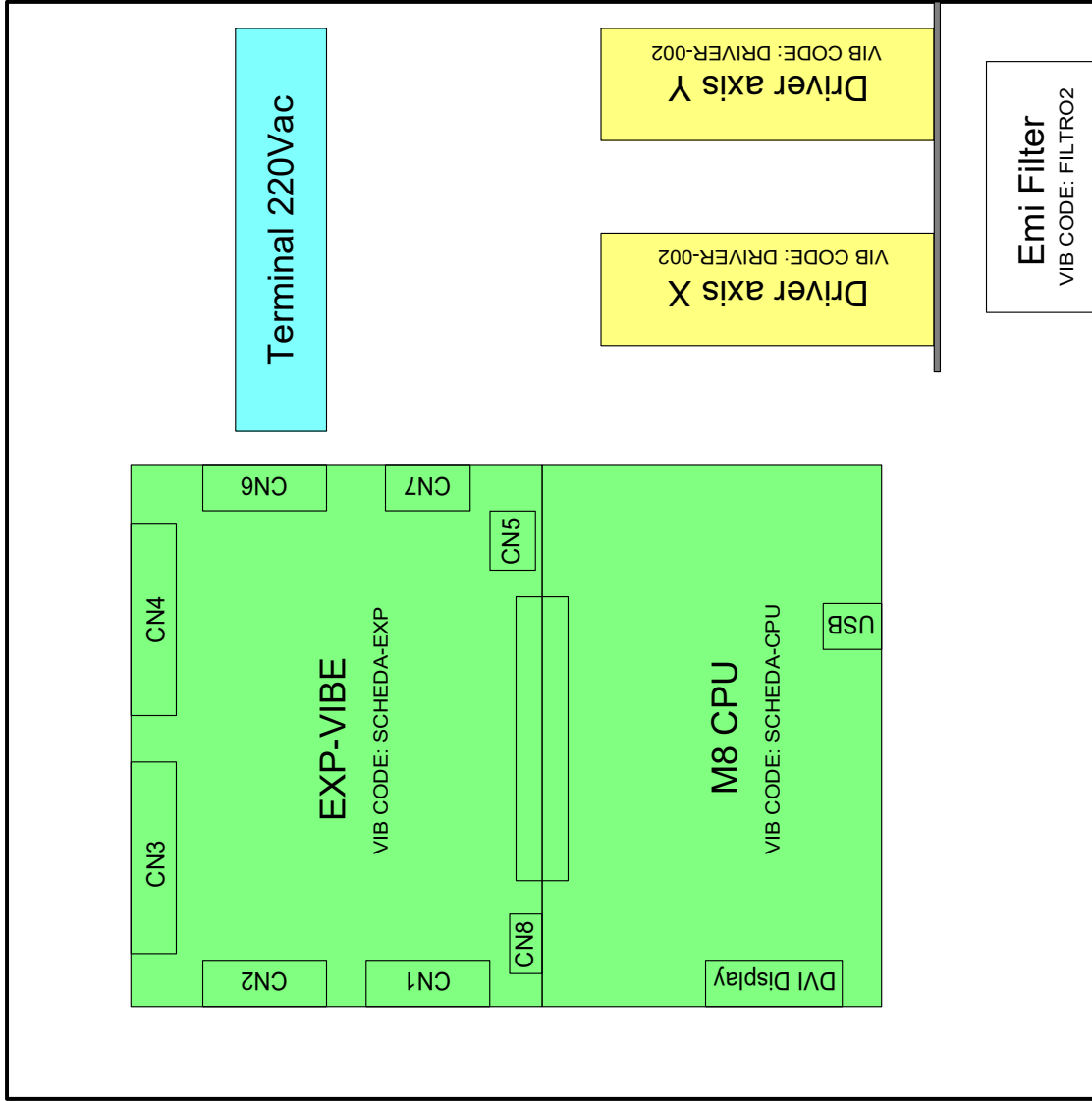

Cable Connections

- CN1: CB8C Mitsubishi Exp-Vibe
- CN2: CB10C Driver Exp-Vibe
- CN3: CB3C Output Valve Cable
- CN4: CB2D Loading Carriage Input Cable
- CN5: Ethernet Cable from keypad
- CN6: Not connected
- CN7: Not connected
- CN8: Power supply

Title	4650EV9@UP2 Topographical Arrangement		
Author	Campedelli Luca		
File	Electric Diagram_4650EV9_UP2_V1.2_ENG.dsn		
Revision	1.2	Date	13/12/2017
Document	Document		15
Sheets	Sheets		15

29. PNEUMATIC DIAGRAM

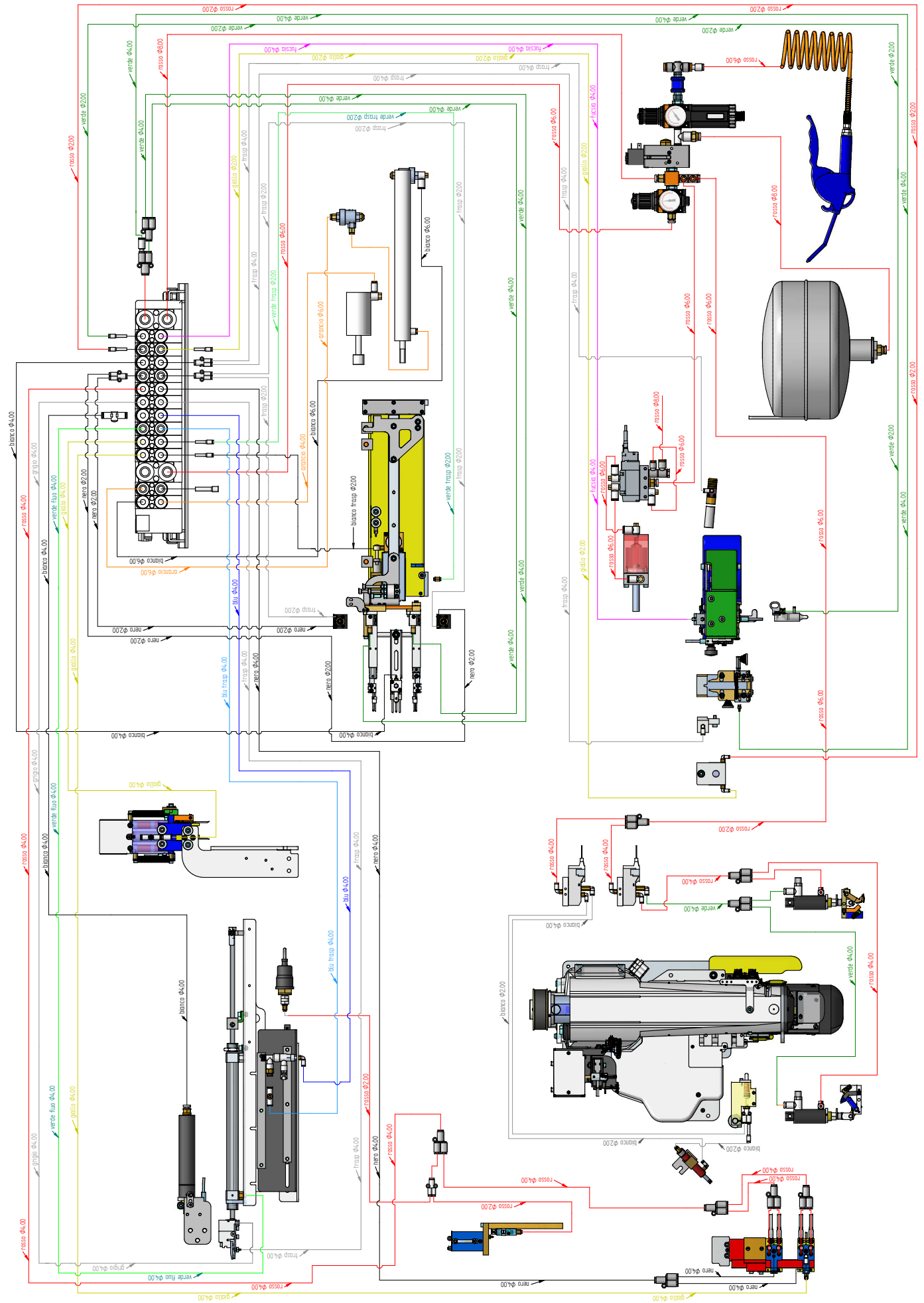

vbm  DISTRIBUTOR FOR

 **VI.BE.MAC.**

Via Monte Pastello 7/i 37057
S. GIOVANNI LUPATOTO (VERONA), ITALIA
Tel. (+39) 045 8778151 - Fax (+39) 045 8779024
Web Site: www.vibemac.com Email: customercare@vbm-grp.com