



ADF-A/LK-1903/A

Operation Manual



Shanghai Weishi Mechanical CO. LTD.

Address: 52#, No.1089, North Qinzhou Road, Shanghai

Postal Code: 200233

Phone: 64953003, 64958277, 64955983; Fax: 64957015

Preface

This manual is written for technical service staffs and operating personnel.

In the Operation Manual for sewing machine preservers in the garment factory and the sewing operators, we have made a thorough explanation on how to use this sewing machine. So in this Service Manual, we will make some explanations on particular and relevant functions, on the adjustment methods for compiling, on the phenomenon resulted from changes in value and other various functions.

In addition to this manual, please refer to other Operation Manuals and parts list when preserving and repairing this machine.

For a safe adjustment operation.

Before adjusting the sewing machine, the automatic machine and the appendant devices (hereinafter called the machine), the operator should read the machine's "Important Safety Instructions" carefully and understand it fully.



The "Important Safety Instructions" in this Service Manual explains some items which are not included in the machinery specification you bought.

Besides, in order to make you fully understand this Service Manual and the warning signs stickup in the machine body, the warning signs are used separately according to the following descriptions.





You should fully understand and consciously comply with its contents.

Adjustments: Parts' replacement, removal, repair, assemble and other operations.

(1) Descriptions about the dangerous level

 Danger	When operating and maintaining the machine, the dangerous parts which could cause death or serious injury by the third person's misoperation and the privies couldn't avoid.
 Warning	The potential parts which could cause death or serious injury by the third person's misoperation and the privies couldn't avoid when operating and maintaining the machine.
 Caution	The parts which could cause moderate or minor injury by the third person's misoperation and the privies couldn't avoid when operating and maintaining the machine.

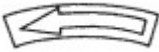
(2) Descriptions about the indications of the warning patterns

Warning patterns		Moving Parts: be cautious of the industrial accident.	Indication Sign		Belt Drive: be cautious of the industrial accident.
		High Voltage Parts: be cautious of electric shock.			Indicate the correct direction of rotation
		High Temperature Parts: be cautious of scalding accident.			Indicate the earth wire that should be earthed.

Important Safety Instructions

Accident: Refers to the physical and property damage.

Cut off the power: Refers to turn off the power switch and pull out the power plug from the socket.



Danger

To prevent the electric shock, when it is necessary to open the electrical cabinet, please cut off the power first and then open the electrical cabinet after at least 5 minutes.



Caution

Basic

1. To prevent human injury, please read and understand this Service Manual before operating. Besides, in order to use this Service Manual easily at any time, please keep it properly.
2. To prevent accidents caused by accidental start, please cut off the power before making any adjustment. When it has to operate with the power on, please do not step on the pedal or press the start button. When leaving the machine, it is necessary to cut off the power.
3. To prevent human injury, please verify whether the connecting terminal, cable and other thins are damaged, loosen and so on after making adjustments.

Education

1. To prevent human injury when adjusting the operation, the person who is responsible should be taught about the latest information and safety knowledge, and be trained to operate according to this Service Manual and the Operation Manual.

Mechanical

1. To prevent the accidents caused by misadjustments, the adjustment should be made according to this Service Manual and the Operation Manual by the maintenance technician who is familiar with mechanistic relations and has been trained about the safety knowledge.
2. Please use the genuine components made by our company when replacing components. Our company shall not bear the responsibility for the incidents caused by inappropriate adjustment and for the using of the components which are not made by our company. If the adjustment can't be made within the range of indication, you should terminate the repairing work immediately and authorizes the technician in our company or in the agency shop to solve.
3. To prevent human injury, please verify whether the screws and nuts are loose after making adjustment.

4. To prevent human injury, when unexpected things happen during adjustment or machine still can't work normally after adjustment, please stop operating immediately.
5. To prevent human injury, when adjusting, the safety devices removed or damaged should be installed at its original place and verify whether they are normal and valid.
6. To prevent human injury, the warning signs stickup in the machine should be able to see clearly at any time. When they are desquamated or contaminated, you should replace a new one immediately.

Electrical

1. To prevent accidents and electric shock, please authorize the specified person with electrical knowledge or the technician in our company or in the agency shop to make the adjustment.
2. To prevent human injury, if the fuse blows out, please cut off the power, find out the cause, eliminate the trouble, and then replace a new fuse with the same capacity (specification).
3. To prevent human injury, please verify whether the connecting terminal, cable and other things are damaged, loose and shed after making adjustments.

Air-pressure

1. To prevent accidents caused by accidental start, when using air cylinder and other air-pressure components to make adjustment, please cut off the air supply and drain the internal compressed air first.
2. To prevent accidents caused by faulty action, please verify whether there is water in cylinder and air tube.

Mechanical adjustment in clutch motor

1. After cutting off the power, the clutch motor will continue to spin because of its inertia. To prevent human injury, please start to adjust after verifying the motor has stopped.

Mechanical application and transformation

1. To prevent human injury, do not make any adjustment or transformation which is not complied with the specifications of the machine. Our company shall not bear any responsibility for the accidents caused by such adjustment or transformation.
2. To prevent human injury, do not operate exceeding the machine's using range or the usage specified in this Service Manual and the Operation Manual. Our company shall not bear any responsibility for the accident caused by such operation.

 **Caution**

Move

- 1、 To prevent human injury, please use two or more than two persons to lift this machine and use a moped to move it.
- 2、 To prevent human injury, please adopt sufficient safety precautions to prevent accidental drop and turnover when lifting or moving.
- 3、 We have made a thorough explanation about the installation in the Operation Manual, please read carefully and fully understand before operating.

Component Replacement

- 1、 To prevent human injury, please replace the component under the direction of this Service Manual and the Operation Manual.
- 2、 To prevent occupational injury and human injury, please operate after cutting off the power.
- 3、 To prevent human injury, please operate after the machine has been installed steadily. Meanwhile, it is necessary to choose appropriate tools.
- 4、 To prevent human injury, please verify whether the screws and nuts are loose, whether they have unexpected contact with other components after finishing operation.
- 5、 Please use the genuine components made by our company to replace.

Our company shall not bear any responsibility for the accidents caused by the using of the components which are not by our company.

If you couldn't replace the components normally under the direction, please stop repairing and contact with the technicians in our company or the agency shop.

Adjustmen

- 1、 To prevent human injury, please make adjustments within the range indicated in this Service Manual and the Operation Manual.
- 2、 To prevent human injury, please operate after the machine has been installed steadily. Meanwhile, it is necessary to choose appropriate tools.
- 3、 To prevent human injury, please verify whether the screws and the nuts are loose, whether they have unexpected contact with other components after finish operating.
- 4、 To prevent human injury, when it has to operate with the power on, please be careful enough and do not press the button accidentally.
- 5、 To prevent human injury and being involved in the machine, please be careful enough and do not let your hair or clothes touch the transmission part when operating sewing test.

Disassemble, Assemble

1. To prevent human injury, please make adjustments within the range indicated in this Service Manual and the Operation Manual.
2. To prevent human injury, please operate after the machine has been installed steadily.
3. To prevent human injury, please verify whether there is unexpected contact between components after finishing assemble.
4. To prevent human injury, when solidifying the screw and the nut, if there is specified torsional moment, please solidify in coincidence with the requirement; if there is no such requirement, please solidify in an appropriate torsional moment.
5. To prevent human injury, please verify whether the direction of rotation is correct during trial running.
6. To prevent human injury during trial running, please be careful enough and do not let your hair or clothes touch the transmission part.

 **Caution****Move**

1. To prevent human injury, please use two or more than two persons to lift this machine and use a moped to move it.
2. To prevent human injury, please adopt sufficient safety precautions to prevent accidental drop and turnover when lifting or moving.
3. We have made a thorough explanation about the installation in the Operation Manual, please read carefully and understand fully before operating.

Component Replacement

1. To prevent accidents and electric shock, please authorize the technicians with electrical knowledge to operate.
2. To prevent the accidents and electric shock, when it is necessary to open the electrical cabinet, please cut off the power first and then open the electrical cabinet after at least 5 minutes. Do not operate when your hands are wet.
3. To prevent human injury, please replace the components under the directions in this Service Manual and the Operation Manual.
4. To prevent human injury, please operate after the machine has been installed steadily. Meanwhile, it is necessary to choose appropriate tools.
5. To prevent human injury, please verify whether this component has unexpected contact with other components after replacing and verify whether the connecting terminal and the plug are poor contact, whether the screws and nuts are loose.
6. To prevent human injury, please verify whether the connecting terminal, cable head are damaged, shed or loose after operating.

According to the request of security, there are some floating polyvinyl chloride tube, insulating tape and other insulating materials, and the internal wiring adopt the circuitous way in order to keep away from the high-tension line. And all of them should be reprimed after operating.

7. Please use the genuine components made by our company to replace.

Our company shall not bear any responsibility for the accidents caused by the using of the components which are not made by our company.

If you couldn't replace the components normally under the direction, please stop repairing and contact with the technicians in our company or in the agency shop.

8. To prevent human injury, if the fuse blows out, please cut off the power, find out the cause, eliminate the trouble, and then replace a new fuse with the same capacity (specification).

Adjustmen



1. To prevent accidents and electric shock, please authorize the technicians with electrical knowledge to operate.
2. To prevent the accidents and electric shock, when it is necessary to open the electrical cabinet, please cut off the power first and then open the electrical cabinet after at least 5 minutes. Do not operate when your hands are wet.
3. To prevent human injury, please make adjustments on the adjustable components (variable inductance, potentiometer, variable capacity) according to the indications in this Service Manual and the Operation Manual only
4. To prevent human injury, please operate after the machine has been installed steadily. Meanwhile, it is necessary to choose appropriate tools.
5. To prevent human injury, please verify whether the screws and the nuts are loose, whether they have unexpected contact with other components.
6. To prevent human injury, please verify whether the connecting terminal, cable head are damaged, shed or loose after operating.
7. To prevent human from injury and being involved in the machine, please be careful enough and do not let your hair or clothes touch the transmission part when operating sewing test.

Disassemble, Assemble

1. To prevent human injury, please make adjustments within the range indicated in this Service Manual and the Operation Manual.
 2. To prevent the accidents and electric shock, when it is necessary to open the electrical cabinet, please cut off the power first and then open the electrical cabinet after at least 5 minutes. Do not operate when your hands are wet.
 3. To prevent human injury, please replace the components under the directions in this Service Manual and the Operation Manual.
 4. To prevent human from injury, please operate after the machine has been installed steadily. Meanwhile, it is necessary to choose appropriate tools.
 5. To prevent human injury, when solidifying the screw and the nut, if there is specified torsional moment, please solidify in coincidence with the requirement; if there is no such requirement, please solidify in an appropriate torsional moment.
 6. To prevent human injury, please verify whether the screws and nuts are loose, whether they have unexpected contact with other components.
 7. To prevent human injury, please verify whether the connecting terminal, cable head are damaged, shed or loose after operating.
- According to the request of security, there are some floating polyvinyl chloride tube, insulating tape and other insulating materials, and the internal wiring adopt the circuitous way in order to keep away from the high-tension line. And all of them should be repristinated after operating.

8. To prevent human injury, please verify whether the direction of rotation is correct during trial running.
9. To prevent human from injury during trial running, please be careful enough and do not let your hair or clothes touch the transmission part.

Important Safety Instructions about ADF-A/LK-1903

 <p>Danger</p>	<ol style="list-style-type: none"> 1. To prevent electric shock, during the power supply importing period, do not touch the components in the electrical cabinet when the motor electrical cabinet is open. 2. After changing pattern, please verify the needle point. Once the pattern exceeds the presser foot, the needle would run into the presser foot and snap. 3. Do not cut off the power supply when the needle is falling. Because the pull line device may snap the needle.
 <p>Caution</p>	<ol style="list-style-type: none"> 1. When power is on, but no display on the operation screen, please cut off the power and verify the supply voltage and the power source specification. 2. To prevent the accident caused by the accidental start, before pressing the start button please verify there is no barriers underneath when coiling. 3. When the power button is off, the setout button is on, and the presser foot button is on, do not put your fingers beneath the presser foot, because the presser foot will automatically fall down.

Safety Device

The machineries and safety devices recorded here are made under the domestic specifications; the devices may be different according to different sale places and different specifications.

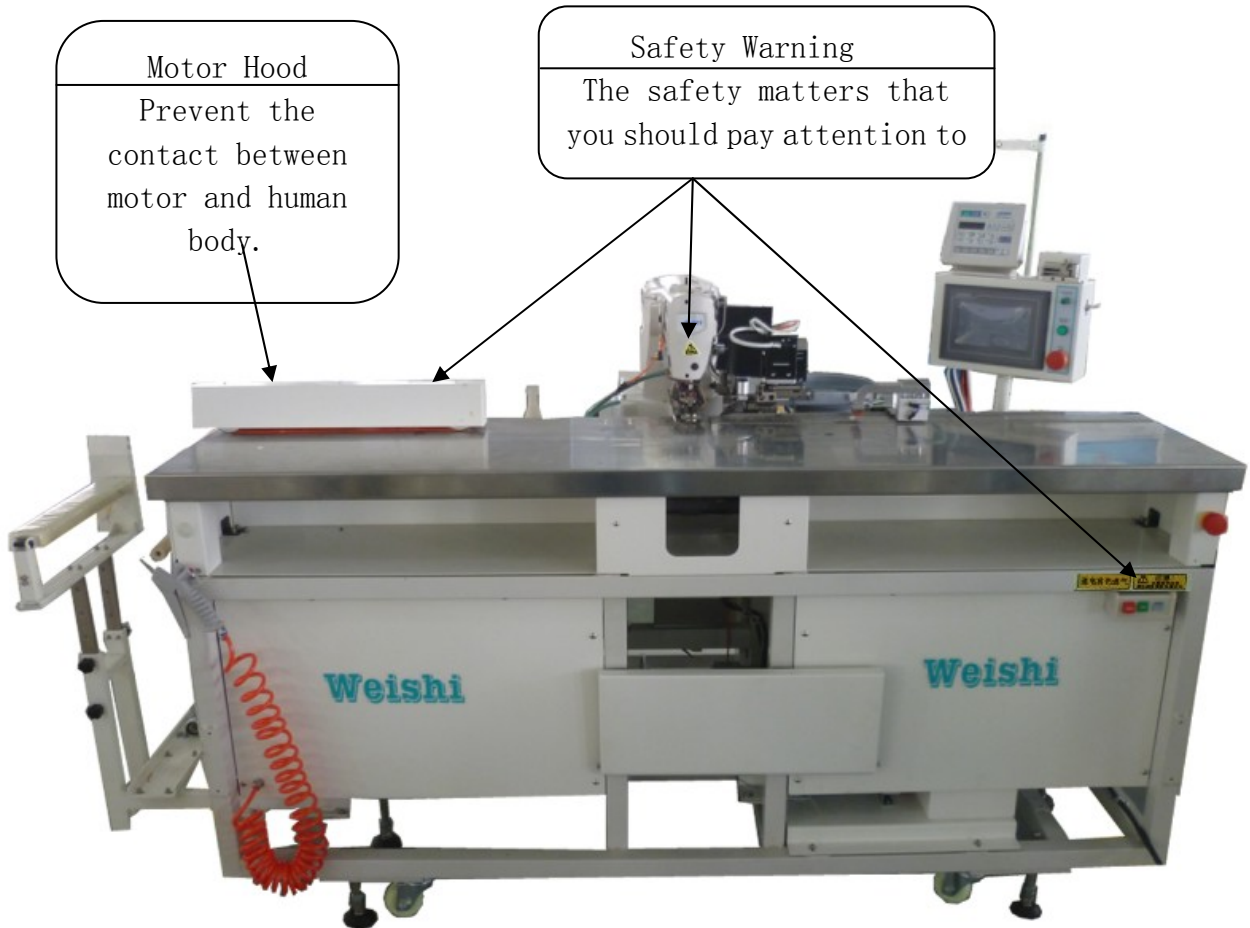

Danger

The book, in some places have been omitted the eye shield, therefore pre-informed you that, in actual use, you should never remove the safety device!

Contents

One. Specification	1
<u>1、 Basic Parameter.....</u>	<u>1</u>
<u>2、 Button Shape.....</u>	<u>1</u>
Two. Names of each part	3
<u>1、 Names of the mainframe.....</u>	<u>3</u>
<u>2、 Name and introduction of control panel.....</u>	<u>4</u>
<u>3、 Stand Adjustment.....</u>	<u>5</u>
(1) Rack level adjustment	5
(2) Adjustment of initial position of the front batter board	6
(3) Adjustment of material-pulling mechanism.....	7
(4) Adjustment of material receiving mechanism	8
(5) Adjustment of fabric location mechanism	9
(6) Adjustment of no button detection switch	10
(7) Adjustment of the initial position of buttoning.....	11
(8) Adjustment of the position of buttoning and button clip	12
(9) Adjustment of the stepping motor in X direction	14
(10) Adjustment of the stepping motor in Y direction.....	15
(11) Adjustment of the stepping motor in Y direction.....	15
(12) Adjustment of the horizontal button feeding.....	16
(13)Adjust the pressure of the rotating rubber head.....	17
(14) Adjust the pressure of the rubber wheel clip	18
(15)Adjustment of the position of spinning head	19
(16) Adjustment of the height of the button arm	20
(17) Height adjustment of presser foot.....	20
(18)Adjustment of the vibration plate	21
(19)Adjustment of the air in air cylinder	22
(20) The adjustment of sewing machine head	22
Three. Operation	23

1、 Operation and running	23
(1) Operation of the sewing machine	23
(2) Operation of the automatic feeding system	23
2、 Function and setting of the operation system	24
(1) Setting of automatic button detection.....	24
(2) Equal interval button parameter setting.....	26
(3) Non-equal button interval parameter setting	27
(4) Parameter Setting	28
(5) Manual Step Operation.....	29
(6) Sewing Machine Testing	30
(7) System Test	30
(8) Operation when line breaking	32
(8.1) Automatically sewing button after resetting the breaking line	32
(8.2) Manually sewing button after resetting the breaking line	32
(9)Operation when stopping	34
Four. Failure Information Chart.....	35
Five. Electrical Schematic Diagram.....	37

One. Specification

1、Basic Parameter

Ordinal	Project	Basic parameters
1	Maximum sewing speed	2700
2	Lifting height of presser	≤13
3	Needle/mm	DP×17 11J-14J
4	Thread	11.8tex~7.4tex×3 (50s~80s/3) Z twisted cotton thread or
5	Button spacing/mm	Arbitrarily set; total length≤655
6	Spacing between button and	10-20
7	Maximum conveying distance	≤650
8	Upper end spacing/mm	≥50
9	Standard button sewing	50 pieces
10	Storage quantity of	20 pieces
11	Setting range of buttoning	2-20 pieces
12	Rated voltage/V	220
13	Operating air pressure/Mpa	0.5
14	Dimension	2200L×1000W×870H
15	Weight	320Kg

※ Maximum sewing speed can be used according to the drop speed of the sewing condition.

2、Button Shape

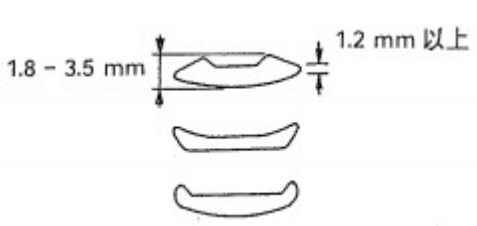
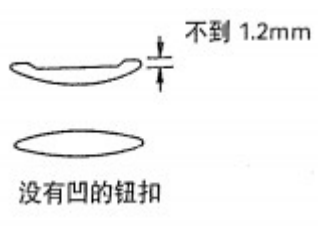
	Button allowed to use	Button not allowed to use
Button shape		

		The shell button (button made of shell)
		The symmetry button (the shape of both top and bottom are the same)
Remark	Button thickness	Buttons with too thick edges may impossible to be sent.

Two. Names of each part

1、Names of the mainframe

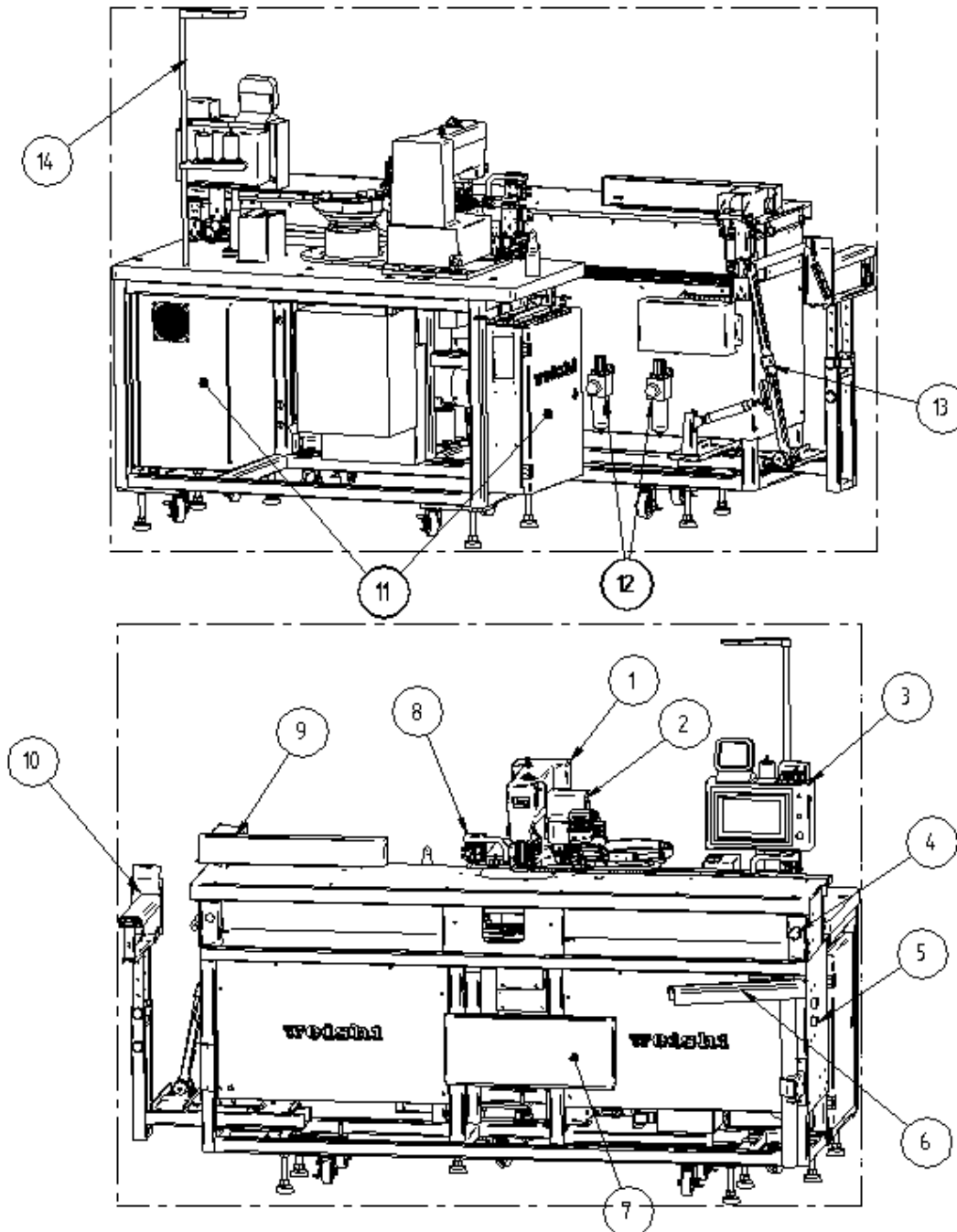

- | | | | |
|---------------------------|------------------|--|------------------|
| 1、 Sewing machine head | 5、 Power switch | 9、 Material collection transmission part | 13、 Knockout rob |
| 2、 Button feeding machine | 6、 Material rack | 10、 Material collecting rack | 14、 Thread stand |
| 3、 Operation board | 7、 Knee switch | 11、 Electrical box | |
| 4、 Emergency stop | 8、 Swaging part | 12、 Filter pressure reducer | |

2、 Name and introduction of control panel

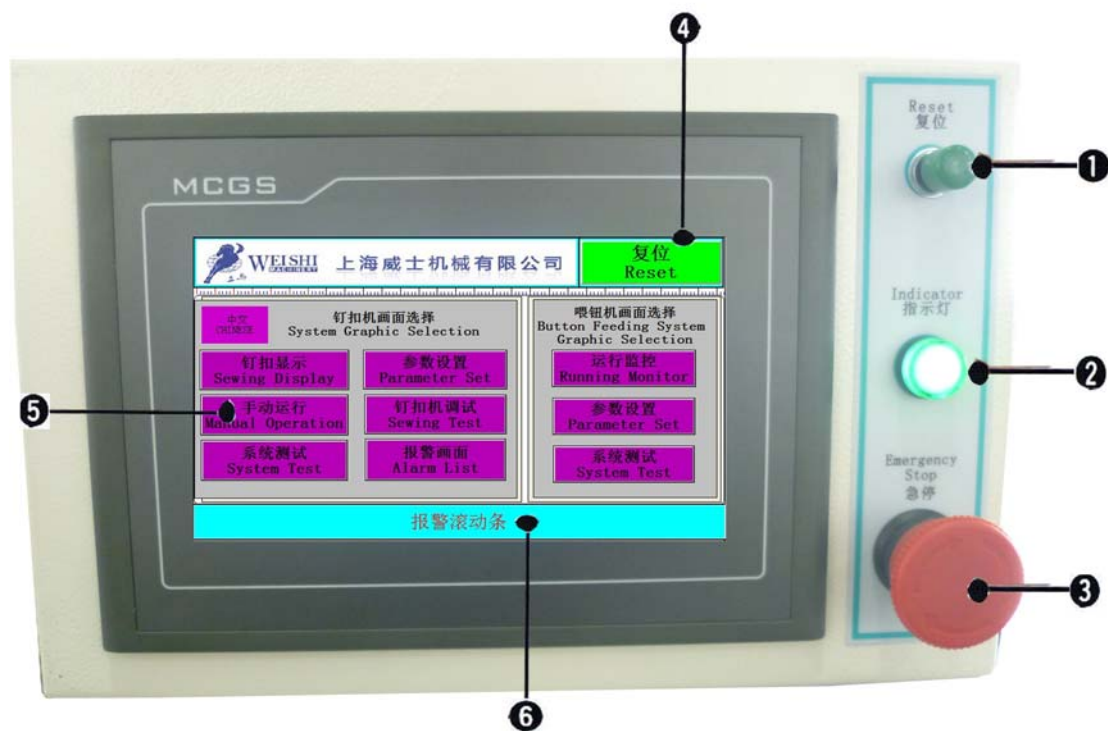

	Button/Display	Content
①	Reset	Press the button, the servo reverting machine enters working state.
②	Indicator	The green indicator light flashes in motor set state, the green indicator light lights in working state.
③	Emergency Stop	Press the button, the system will be reset. Press the green button ④ at the same time to revert back to the origin.
④	Reset	Press the button, the system will execute the next action.
⑤	Operation monitoring and controlling interface	Pressing the relevant button can carry out the operation of sewing set, parameter set, manual operation, sewing test, system test and alarm list respectively.
⑥	Alarm scroll bars	When the system alarms, it shows the relevant alarm information.

3、 Stand Adjustment

(1) Rack level adjustment



Attention

Since the machine is charged with electricity, in order to prevent accidents caused by faulty operation, please do not touch switches that are not necessary to touch.

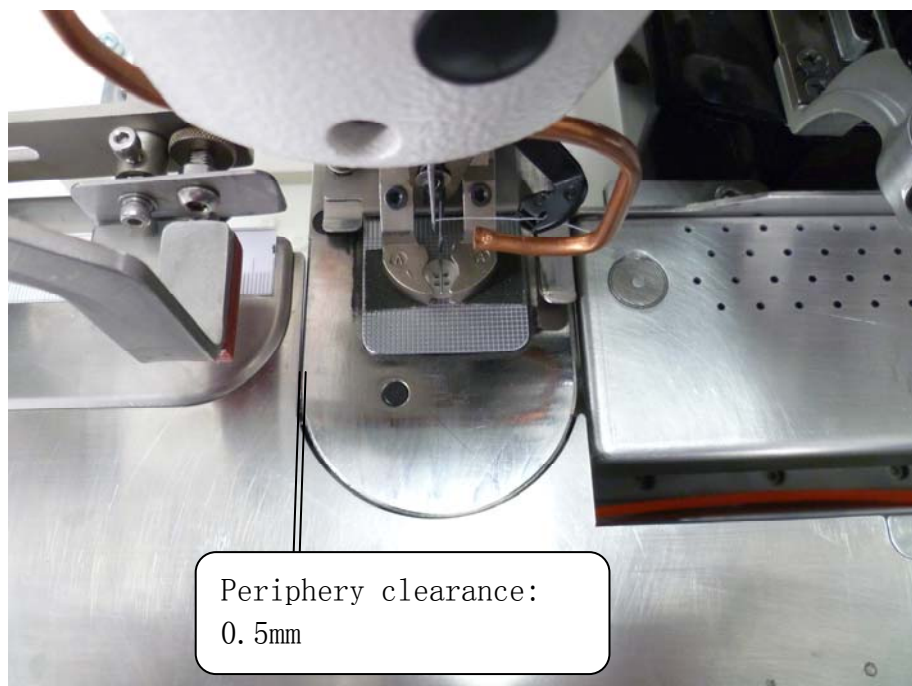

Adjust the foot screw to inosculate the headpiece working table with the R gap on the rack working table, uniformize the periphery clearance and firm the foot screw.

(2) Adjustment of initial position of the front batter board



Attention

Since the machine is charged with electricity, in order to prevent accidents caused by faulty operation, please do not touch switches that are not necessary to touch.

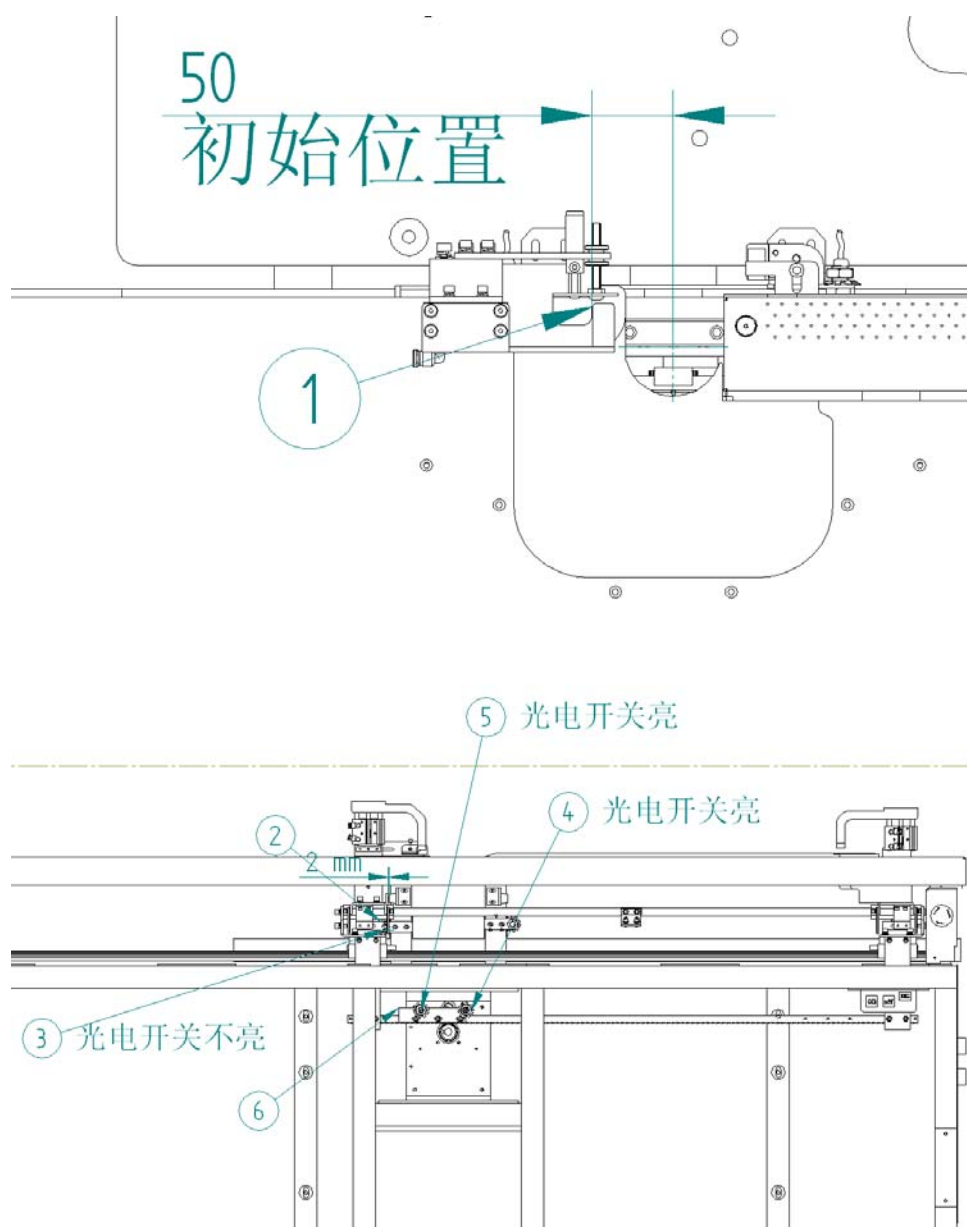

The initial position dimension of fabric front damper is 50mm. Adjust the batter board ① 50mm away from the centre of sewing needle. Adjust the space between limited block and baffle to 2mm, making the optoelectronic switch③ and the induction baffle② maintain closing to light but not bright; adjust the induction baffle ⑥ to make its optoelectronic switch④ maintain shiny and optoelectronic switch⑤ maintain bright.

(3) Adjustment of material-pulling mechanism



Attention

Since the machine is charged with electricity, in order to prevent accidents caused by faulty operation, please do not touch switches that are not necessary to touch.

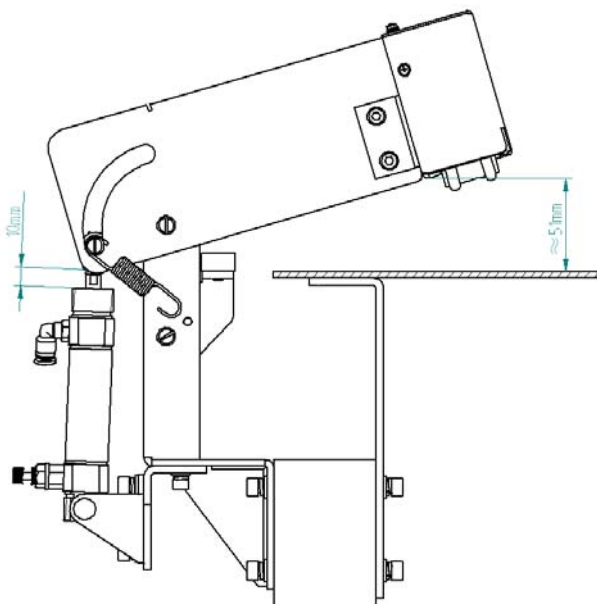

When adjust the material-pulling mechanism, the minimum cylinder stroke is 10mm, the distance between the bottom of the outer tug frame and the surface of working table is 51mm.

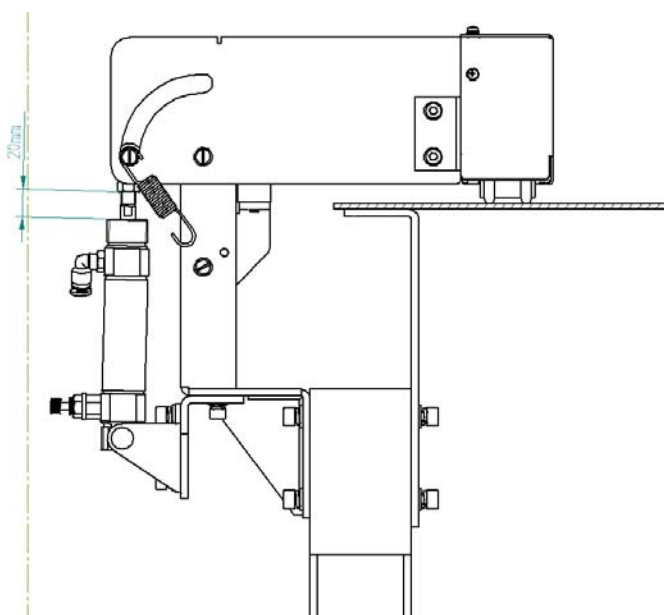

When adjust the material-pulling mechanism, the maximum cylinder stroke is 20mm, material-pulling wheel's rubber belt should keep parallel contact back and forth with the surface of working table, and the pressure is suitable for pulling fabric smoothly and steadily.

(4) Adjustment of material receiving mechanism



Attention

Since the machine is charged with electricity, in order to prevent accidents caused by faulty operation, please do not touch switches that are not necessary to touch.

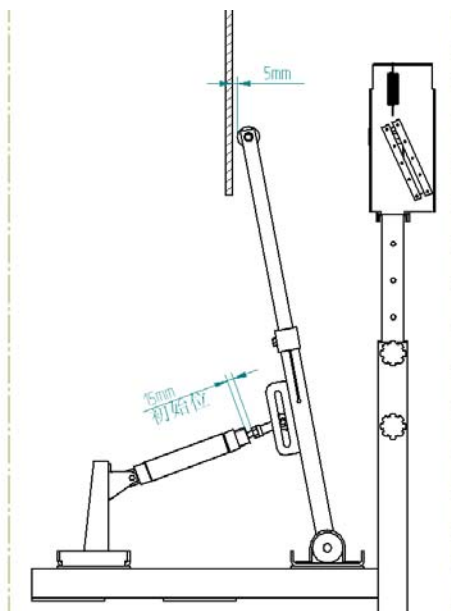

When adjust the material receiving mechanism, the minimum cylinder stroke is 15mm, the distance between the material receiving rods and the rack is 5mm.

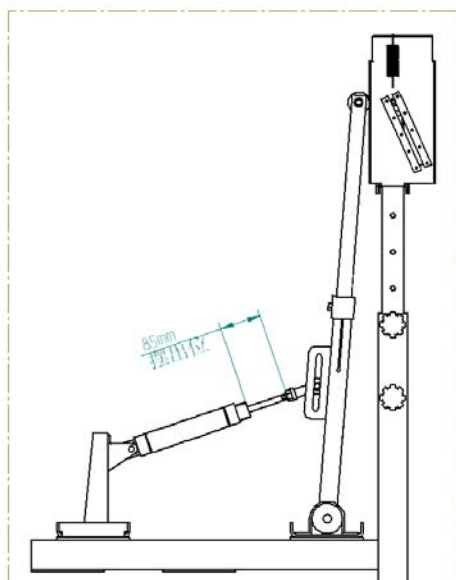

When adjust the material receiving mechanism, the maximum cylinder stroke is 85mm, the material receiving rod parallel to the holder and touch the holder.

(5) Adjustment of fabric location mechanism



Attention

Since the machine is charged with electricity, in order to prevent accidents caused by faulty operation, please do not touch switches that are not necessary to touch.

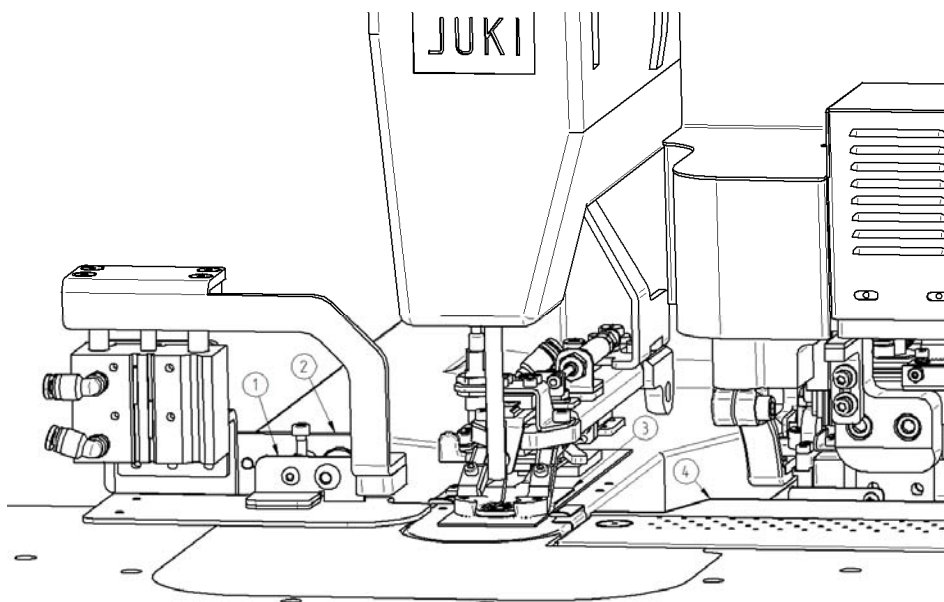

Adjust the headpiece batter board③ as required size, adjust the location of the front pressure plate by the measure of straightedge, loosen the firm screw① and rotate and adjust screw nuts② to be parallel with firm screw③. The adjustment of back baffle④ can be seen as pictures below.

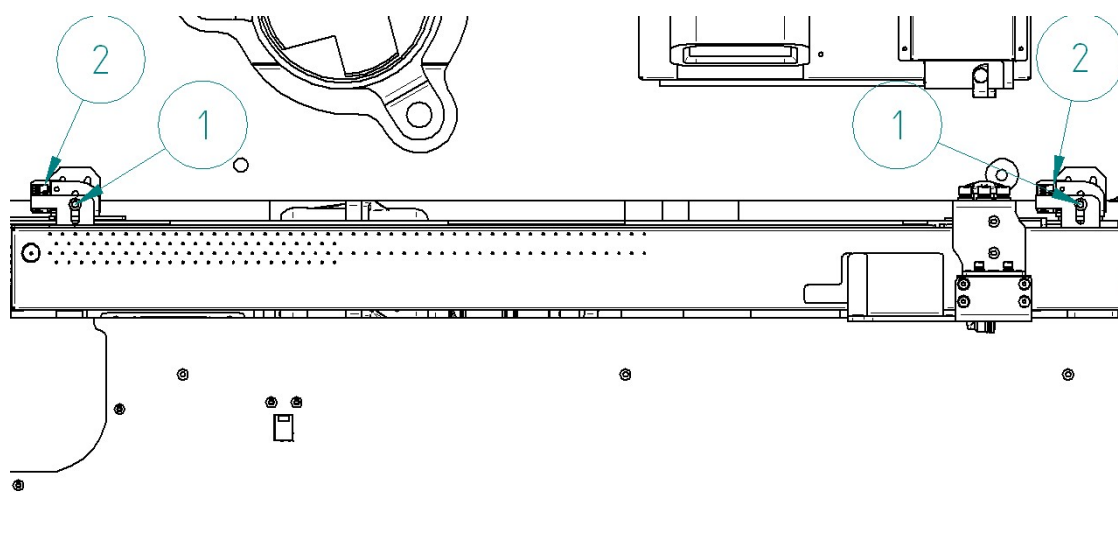

Loosen the firm screw①, firm screw① by adjusting the back damper to be parallel with the headpiece batter board according to the scale②.

(6) Adjustment of no button detection switch



Attention

Since the machine is charged with electricity, in order to prevent accidents caused by faulty operation, please do not touch switches that are not necessary to touch.

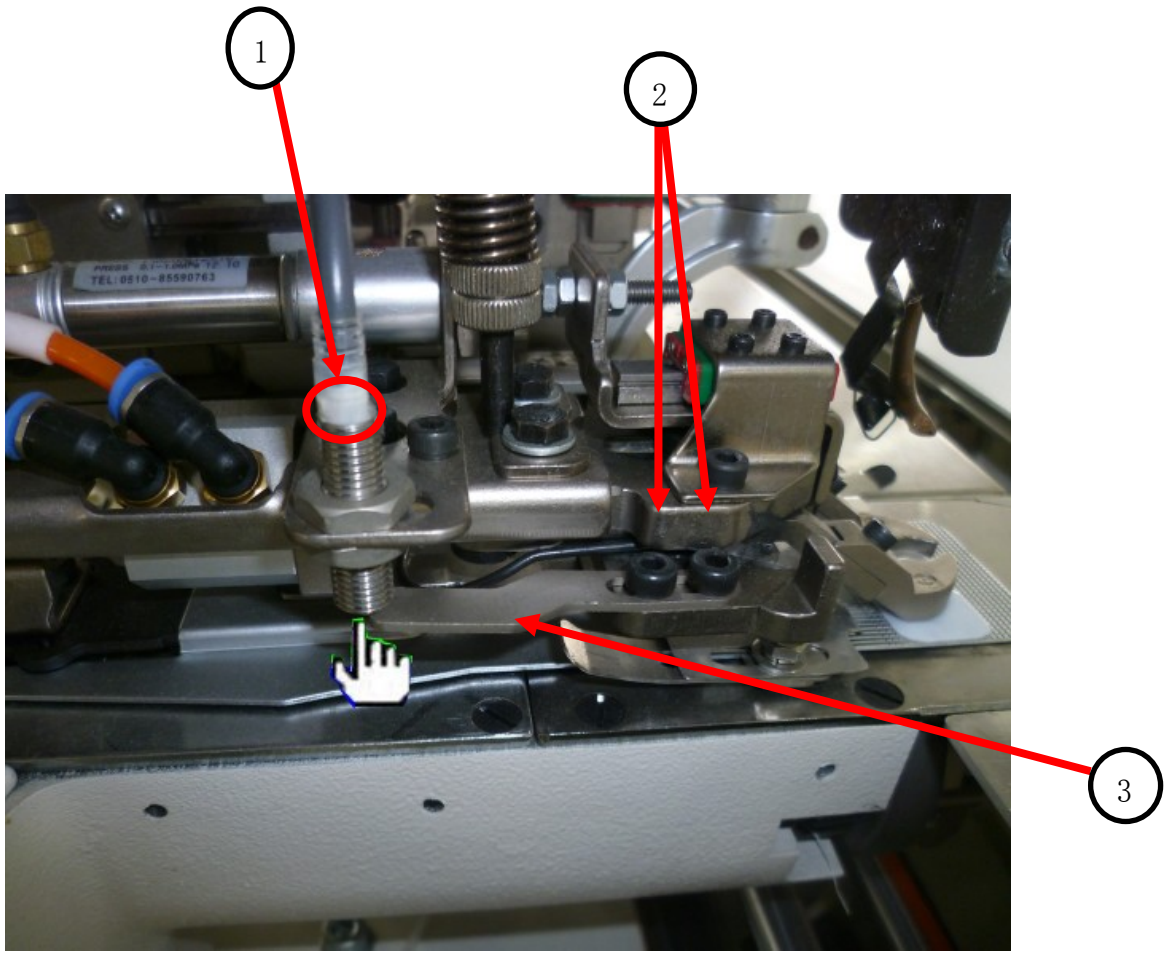

When adjust the button repairing detection switch, in the state of no button, first fix the photoelectric sensor on the stand. After loosening the firm screws ②, adjust the position of the detecting board③, when the red light of optoelectronic switch① is going to light, firm the screw②.

(7) Adjustment of the initial position of buttoning

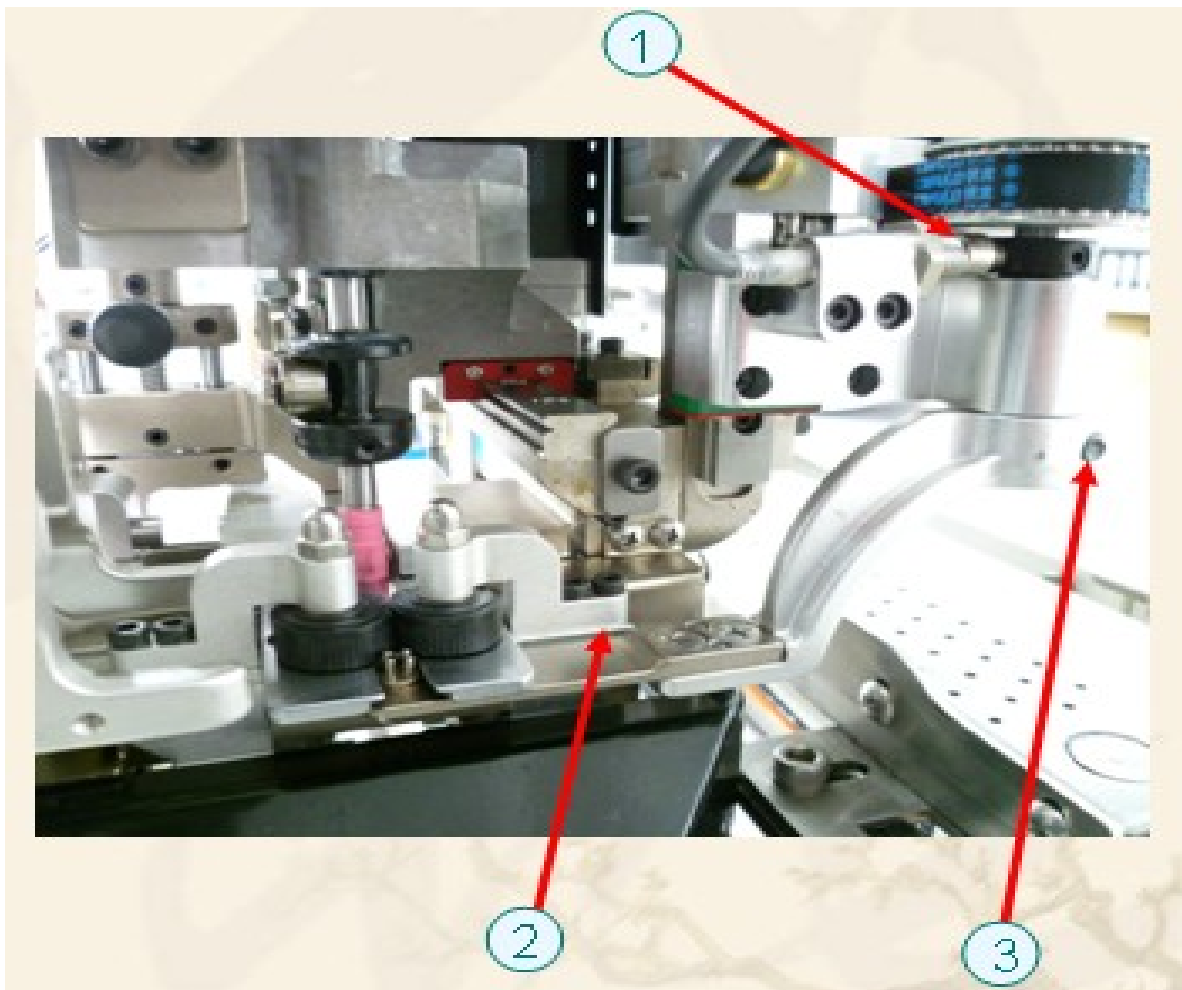

When adjust the initial position of buttoning, after fix the induction screw 1 on the position that close to the switch, loosen the buttoning swing arm and tighten Screw 3, put the buttoning close to positioning stop 2, and firm Screw 3 to finish the adjustment.

(8) Adjustment of the position of buttoning and button clip

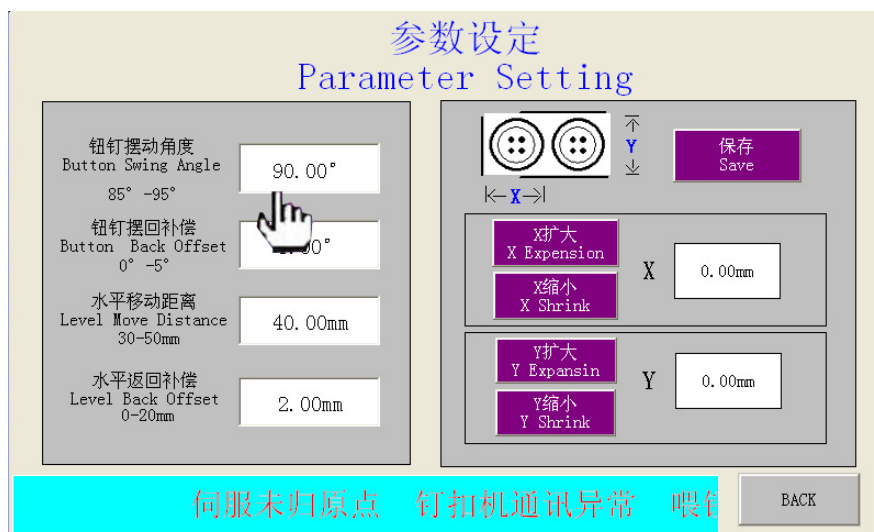

Setting the angle data on “Button Swing Angle” of the button set-in machine’s “Parameter Setting” surface (Range:85° -95° , standard value: 90°), rotate to set the button ’s angle, make sure that buttons can be sent to the button set-in machine accurately.

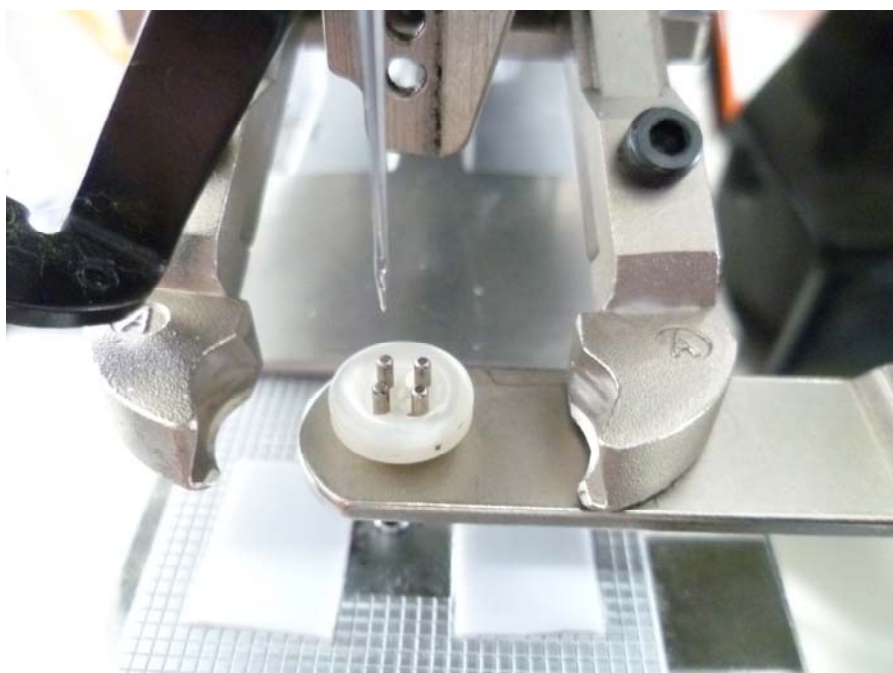

When the buttoning is in the original position, press Damper 1 on “System Testing” surface of button set-in machine to open the outside “damper (Damper 1)” and press “Button Claw” to open button claw. Put a button on button arm, four needles should be aimed at four holes of the button. Press “Button Arm Out” on “System Testing” surface, after the button is swung out, press “Button Claw” to close button claw, and check whether the button clip can clamp the button and whether the buttoning is wagging or not. If the buttoning is wagging, adjust the angle data.

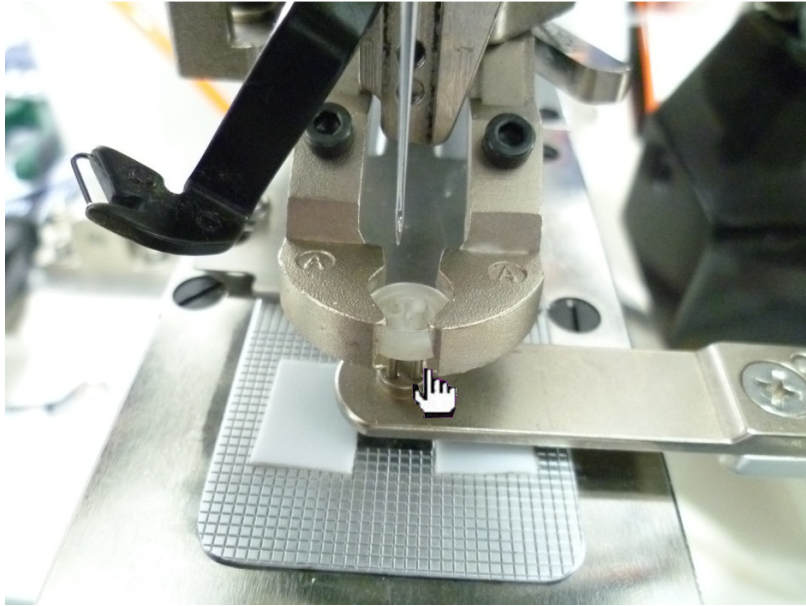

Press "Button Up/Down" to descend button on "System Testing" surface, then press "Button Arm Back" to swing back button arm, and then press "Button Up/Down" to lift button. Repeat actions till the button clip clamp the button and button stop wagging.

(9) Adjustment of the stepping motor in X direction

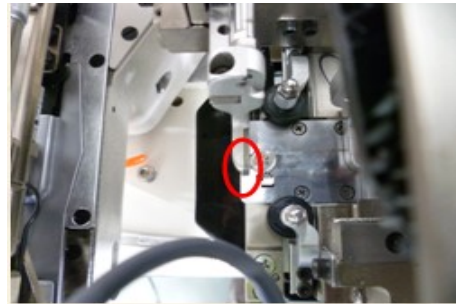

After entering into system testing and drawing back Damper 1 through clicking "Damper 1", put testing button on button arm and check the clearance size between baffle and button after resetting Damper 1.

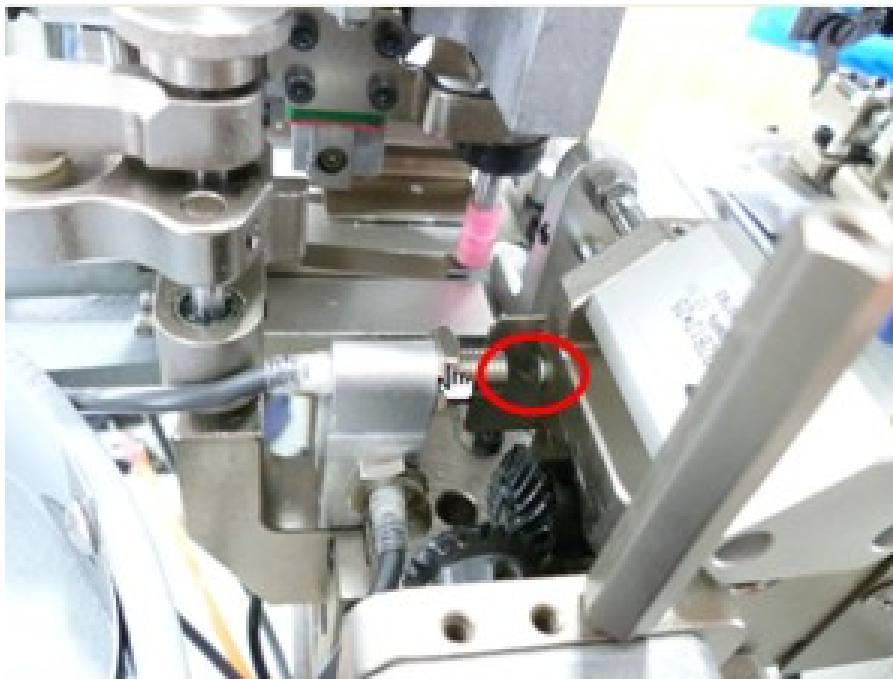

Adjusting the distance between proximity switch and detecting point to make it meet the requirement of slight contact between baffle 1 and button. (If the distance between Damper 1 and button is large then widen the distance between proximity switch and detecting point; if the distance between Damper 1 and button is small then shrink the distance between proximity switch and detecting point.)

(10) Adjustment of the steeping motor in Y direction

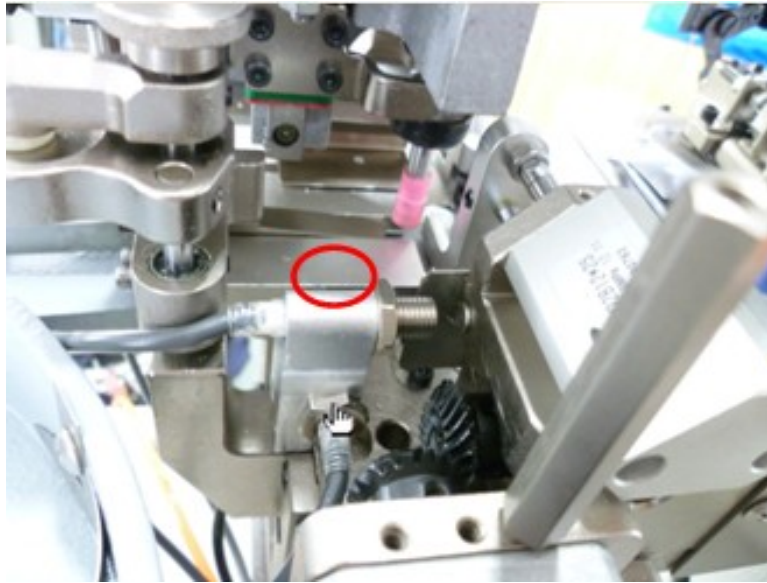

Adjust the distance between proximity switch and detecting point to meet the requirement that the coincidence channel is larger than the width of button so that the button can slip without resistance. (Manually adjust the distance on system testing when the button is irregular, and press the “Save” button.)

(11) Adjustment of the steeping motor in Y direction

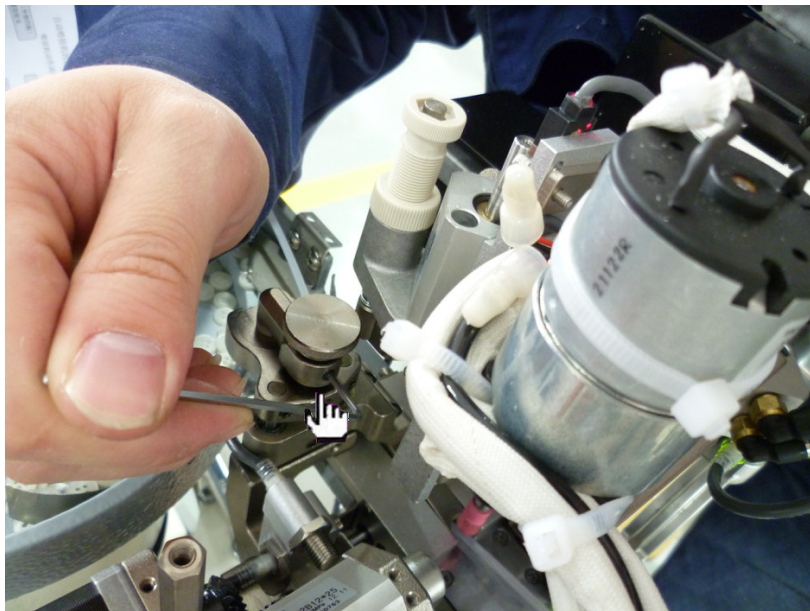

Put two buttons, which are 0.5–0.7mm higher on both ends of the button channel. Put a button on button thickness measure place which is above the channel, and then firm the tested setscrew. (If it's too low, buttons could not go through; if it's too high, double layer buttons could appear.)

(12) Adjustment of the horizontal button feeding

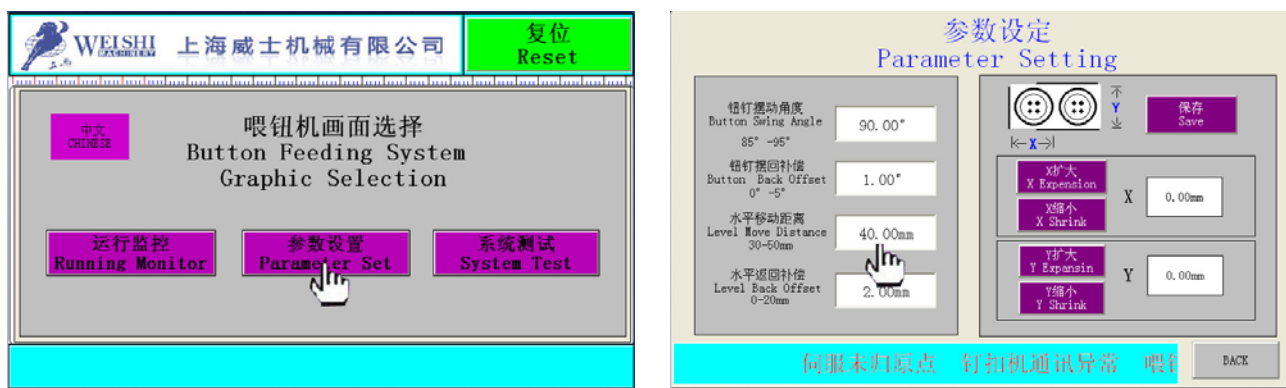

Press "Parameter Set", enter the parameter setting interface, and set the initial distance as 40mm. "Level Back Offset" used to make fine-adjustment (range :0--5mm).

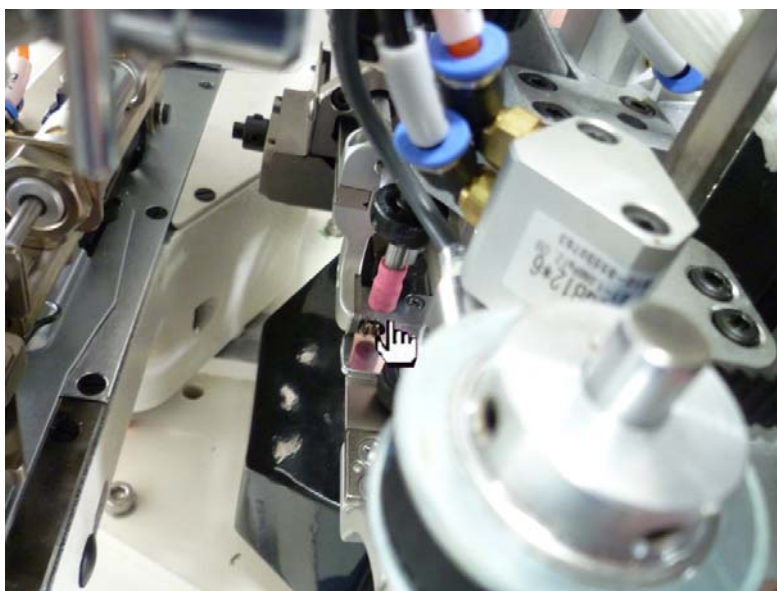

Adjustment of the initial position of level move: the standard for this adjustment is to make the rubber knob down to the notch of the button screw knob and the exit end of the channel Y (within the inside baffle), and just press the button right in the center.



Adjust the distance between the proximity switch and the detecting point, and make the rotating rubber sleeve at the center between the button screw center and the exit end R of the channel Y.

(13) Adjust the pressure of the rotating rubber head



The pressure of the rubber knob head is adjusted by spring compression. The adjustment hand shank is a vertical white plastics cylinder on the top. Rotating in clockwise direction is increasing the pressure; rotating in anticlockwise direction is decreasing the pressure. If the pressure is too small, the rubber knob head will down slowly, and it will block of the motion coherence; if the pressure is too great, the rubber knob head tied up in a button, and it will block the button dragging. So this pressure should be slightly small, and it must meet the rubber knob head's rapid descent.

(14) Adjust the pressure of the rubber wheel clip

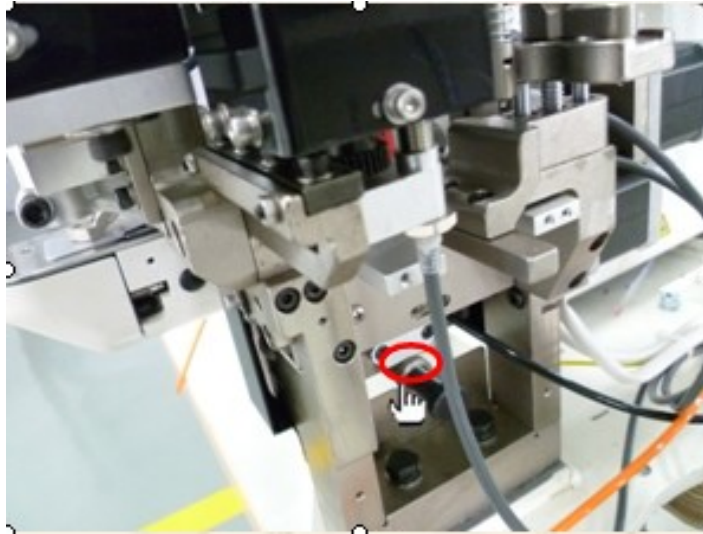

The pressure of rubber wheel clip will also influence the rotating of the button. The pressure of rubber wheel clip is adjusted by spring compression. The adjustment place is below the channel and at the bottom of the erection support.

If the pressure is too small, the rubber roller clamp couldn't close and couldn't touch the button, so it couldn't find out the center through rotating. Turning the knob in clockwise direction, the pressure will increase.

If the pressure is too great, the clip will squeeze the button.



Press the "Damper 1" button in "System Test" interface to open the outside damper (damper 1); press the "Rubber Wheel Clip" to open the rubber wheel clip; put a button in the button arm, make the four needles aim at the four holes; then press "Rubber Wheel Clip" again to shut the rubber wheel clip, and check whether the clip will squeeze the button and make the button and button arm offset. If they are offset, then turning the knob in anticlockwise direction to reduce the spring until the clip could squeeze the button slightly when it is closed.

(15) Adjustment of the position of spinning head



Detecting on the button sensor at the bottom of rubber spinning head is to detect whether the button is detected or not when the rubber spinning is descending in the initial position. It's aimed to protect the rubber spinning head. The sensor is above the cylinder of the rubber spinning head lifting.

The sensor adjuster will keep bright and have signal when the rubber swivel head is lifting; when dragging the button, the sensor will keep bright and have signal if there is button at the bottom, but once there is no button at the bottom and the rubber swivel head is pressed to the base, the sensor will out and have no signal. By this time, having no signal means there is no button and the rubber swivel head will be lifted automatically, but other action will be continuing.

(16) Adjustment of the height of the button arm

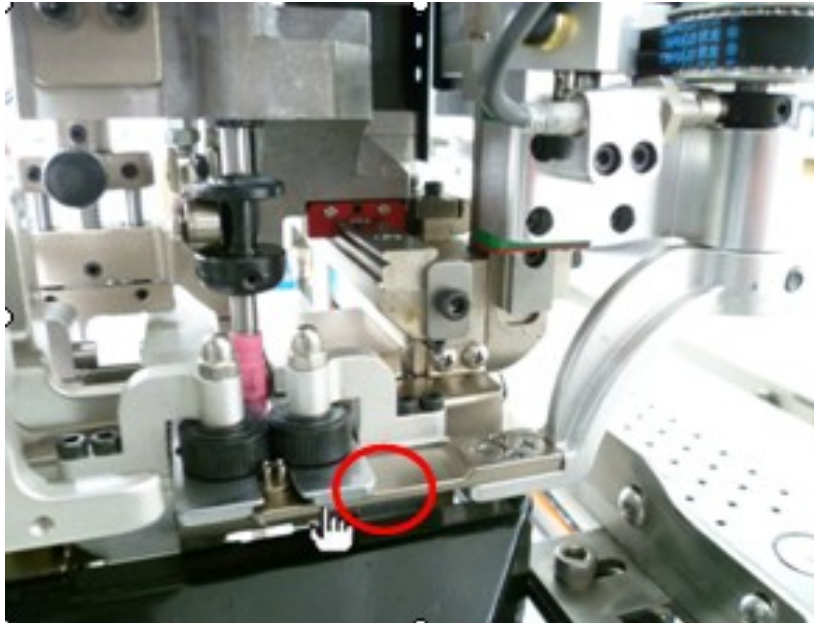

Button arm's upper limited position: when the button is lifting, maintain some 0.1mm gap between the button plane and the bottom of the knob platform.

(17) Height adjustment of presser foot

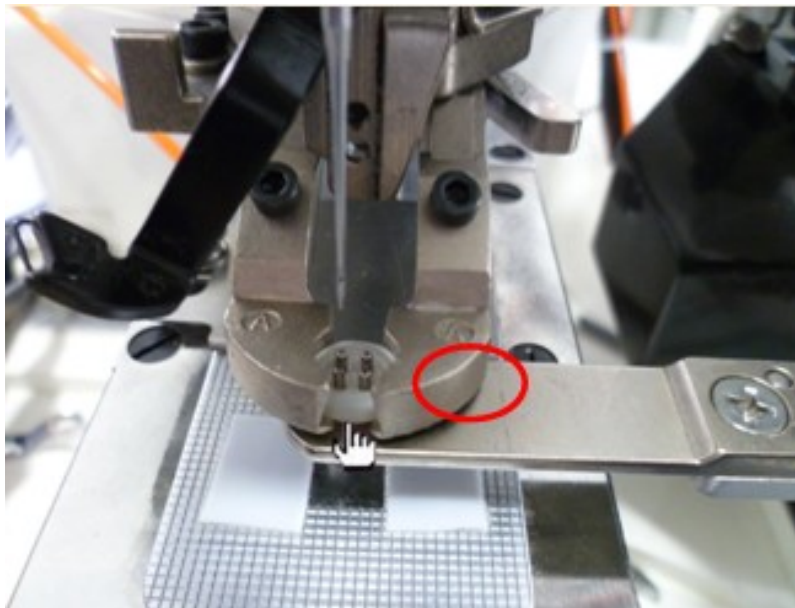

Height adjusting standard of the presser foot: When the button is in clip button position, while the button is lifting, the button clip should be clipped on the 4 needles pillar and button clips inside platform should be a little lower than the pillar platform.

Adjust the relative position between the whole presser foot and the bracket that drive the presser foot move up-and-down. (To loosen the connection screw, the presser foot should be lowered, the bracket should be pushed back; the presser foot should be raised and the bracket should be pushed forward.)

(18) Adjustment of the vibration plate

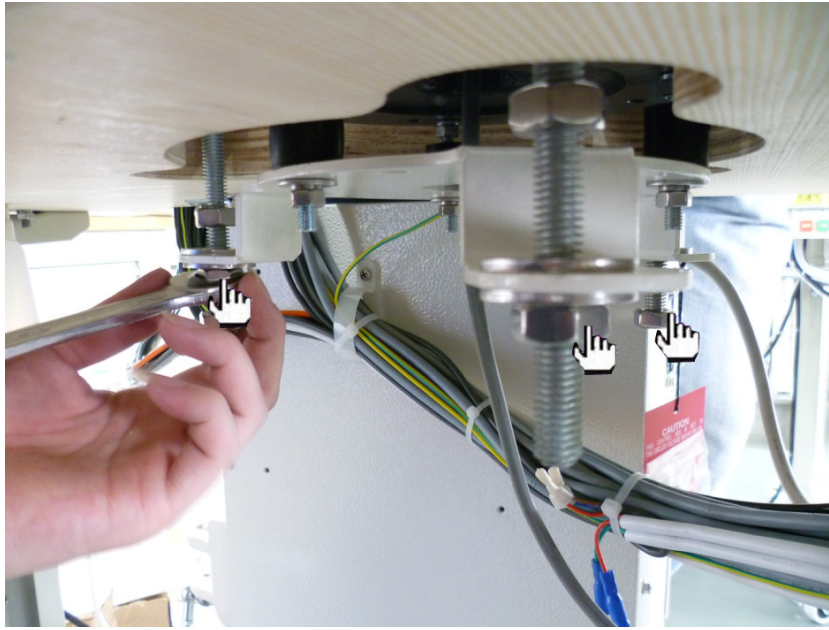

The adjustment of vibration plate generally lies in adjusting the potentiometer knob beside the touch screen. If the vibration amplitude cannot be increased after adjusting the potentiometer knob, consider the possibility of interference between the vibration plate and objects around. Check out firstly whether there' s touching around. Or appropriately adjust 3 supporting screws under the vibration plate to adjust the height and amplitude of the vibration plate (please don' t adjust the 3 screws unintentionally).

(19) Adjustment of the air in air cylinder



When adjusting the air cylinder, loosen air-adjusting screw of the air-adjusting valve, adjust it till there' s no hitting when air cylinder stretching and in agree with movement requirements.

(20) The adjustment of sewing machine head

Refer to the specification and service manual of LK-1903A

Three. Operation

1. Operation and running

(1) Operation of the sewing machine

- Switch on power, choose pattern P to be sewed
- Enter sewing state

After pressing the preparation key  on the operating plate of machine head, the background light of liquid-crystal display screen turns from blue to green. The machine enters into sewing state.

- Turn on button supply switch and the movement control system of automatic feeding system starts, entering into sewing state, steps on the foot switch and the sewing machine begins to sew.
- Set the parameters, operation and running, maintenance and service of the sewing machine. For concrete operation, please refer to instruction of the LK-1903A sewing machine.

(2) Operation of the automatic feeding system

After completing the parameter setting of button and system, the machine enters into sewing state. Button sewing machine must enter into sewing state.

Concrete operation

-
- (1) Unfold the fabric on the platform; the fabric must cover the photoelectric switch on the platform.
 - (2) Tidying the fabric against the prop.
 - (3) Press the knee switch by knees and hold on, depress the left presser foot to tidy up fabric. If the fabric is found not in place during the process, press stop button and cancel the feeding process.
 - (4) After tidying the fabric, release knees and depress the right presser foot and start sewing.
 - (5) Complete collecting after sewing.

2、Function and setting of the operation system

(1) Setting of automatic button detection



Put the button to be detected at its place of the detection channel



Put the button to be detected at its place of the encoder testing



Press Running Monitor on the main interface to enter into operation interface

Put the button to be detected after pressing button CLEAR



Press SURE



Press ADJUST after the channel completely opens



Press Feeding to enter into sewing state

(2) Equal interval button parameter setting



Press Sewing Display on the main interface to enter the sewing setting interface



Press Sewing Setting to enter the button parameter setting interface

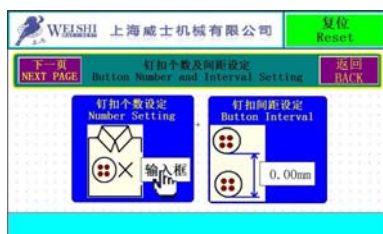

Press Number Setting to enter into the data input box interface



Input the number of button on input box and press SURE



Press Button Interval to enter into input box interface



Input the button interval on data input box and press SURE

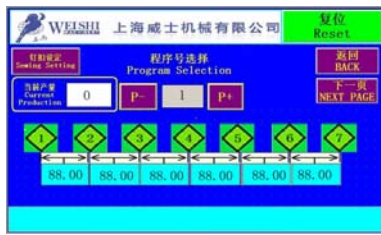

Complete the equal interval button setting; enter into the button display interface.

【NOTE】 The system can set or store 20 groups (No.1~No.20) different button parameters according to different button requests, different button quantity and different button interval.

(3) Non-equal button interval parameter setting



At the "Sewing Display" interface, click the intervals which need to be set individually.



Type the button interval in the Data Input box, and press the SURE button.



After finishing the equal button interval setting, enter into the "Sewing Display" interface.

【NOTE】 The interval can be non-equal, and the setting range is 0--600.0mm, but the total amount of the intervals can't exceed 650.0mm. Otherwise the system will alarm when sewing and stop working.

(4) Parameter Setting

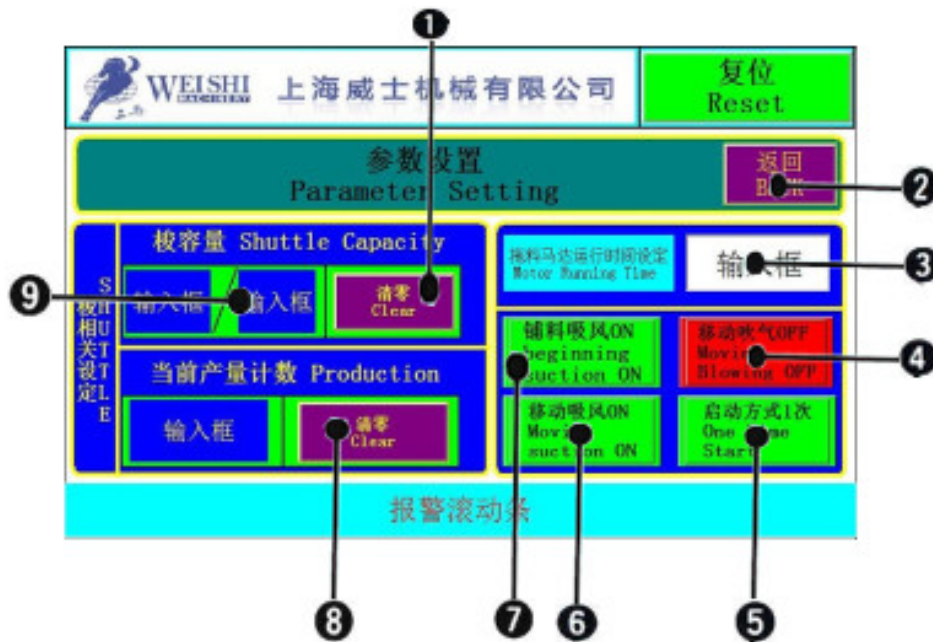

	Button/display	Contents
①	Shuttle Capacity Clear	System will calculate the shuttle capacity automatically, when it isn't able to finish sewing one piece of clothes, the system will alarm. And you need to change the shuttle and click the "clear" button to continue.
②	Back	To return to the previous menu
③	Data Input	Adjust motor running time according to the actual material collecting.
④	Moving Blowing ON/OFF	You can choose whether there is blowing function when cloth moving by pressing this button (when this button on, the machine can guarantee the distances between buttons and the front fly are same.)
⑤	One Time Start	You can choose one time or two times start by clicking this button
⑥	Moving Suction ON/OFF	You can choose whether there is suction when cloth moving by pressing this button.
⑦	Beginning Suction	You can choose whether there is suction when beginning by pressing this button.
⑧	Clear	Press this button to clear the previous number and start to count again.

9	Data Input	<p>Denominator (the second from the left) is the shuttle capacity, indicates how many times button sewing can be made with the shuttle. This data is set according to the test, the experience and the sewing's usage analysis.</p> <p>Molecule (the first from the left) is the finishing number, indicates the how many times button sewing has been made.</p>
----------	------------	--

(5) Manual Step Operation

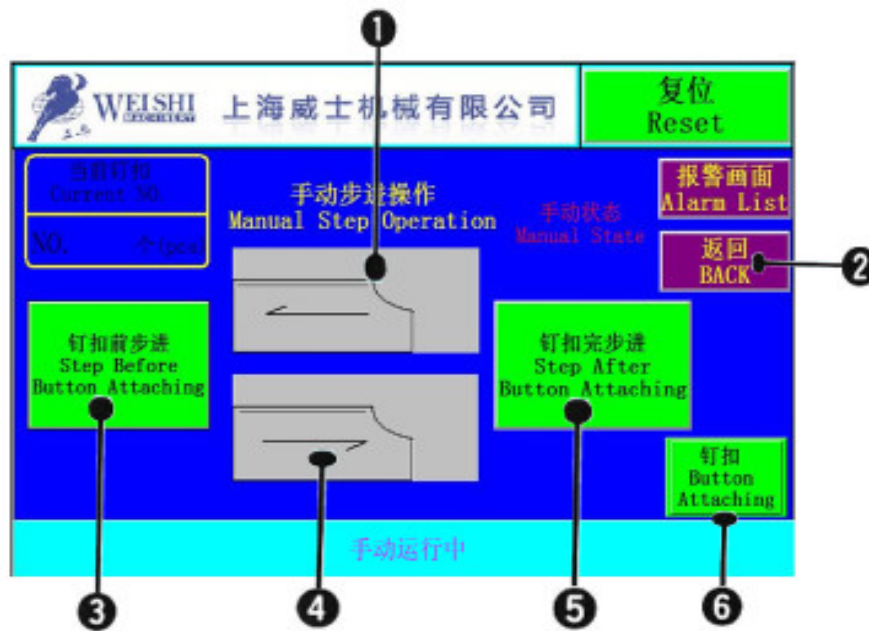

	Button/display	Contents
1	Move Left	Before finishing sewing, only when the convey track is not in the right-hand end (i.e. it can move to the left) will the button be displayed, will the action be effective. After line breaking or pressing the "stop" button. Each time clicking this button, the convey track will move left one button interval.
2	Back	To return to the previous menu
3	Step Before Button Attaching	When there is a piece of cloth covering the sensor on the platform, press the button, the press foot will fall and press. After finishing these actions, this button will hide.
4	Move Right	Before finishing sewing, only when the convey track is not in the left-hand end (i.e. it can move to the right) will the button be displayed, will the action be effective. After line breaking or pressing the "stop" button. Each time clicking this button, the convey track will move right one button interval.

5	Step After Button Attaching	After sewing the button manually, clicking this button to finish the following actions till the servo motor back to the origin and enter to next automatic operation.
6	Button Attaching	Press to finish a button attaching automatically.

(6) Sewing Machine Testing

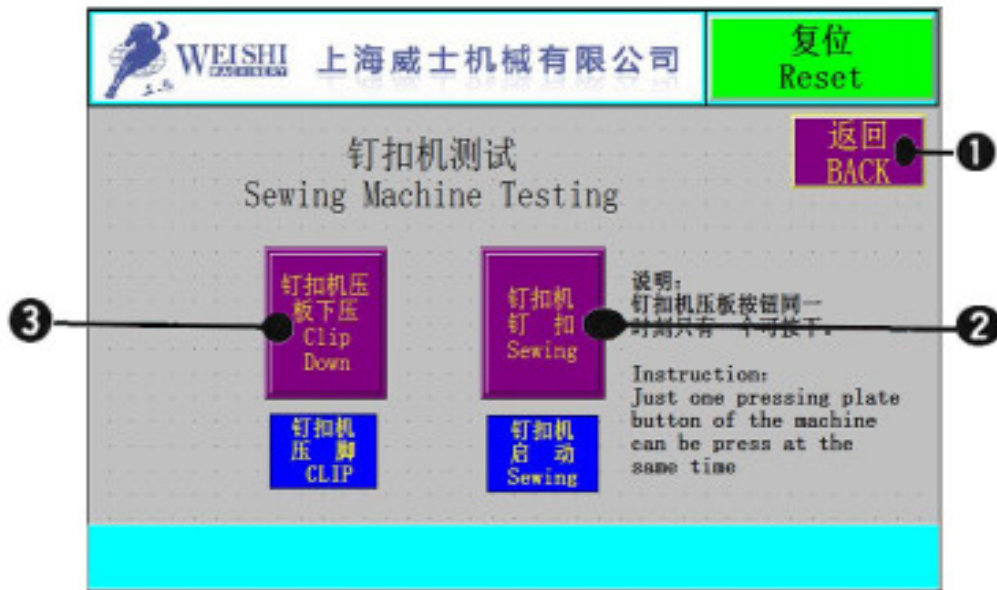

	Button/display	Contents
1	Back	To return to the previous menu
2	Clip	Press this button, the press board will fall. Reset this button the press board will lift.
3	Sewing	Press to start sewing a button

(7) System Test

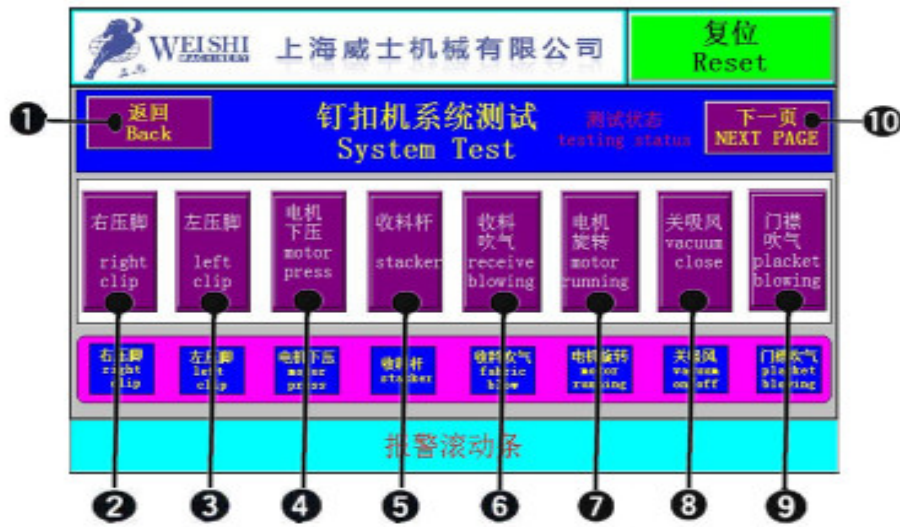

	Button/display	Contents
①	Back	To return to the previous menu
②	Right Clip	Press to test the right clip
③	Left Clip	Press to test the left clip
④	Motor Press	Press to test the motor press function
⑤	Stacker	Press to test the stacker's function
⑥	Receive Blowing	Press to test the receive blowing function
⑦	Motor Running	Press to test the motor running
⑧	Vacuum Close	Press to test vacuum close function
⑨	Placket Blowing	Press to test the placket blowing function
⑩	Next Page	Press to enter to the next page

【Note】 : On this interface when a button is pressed, the system will not start automatically, please reset all the buttons, or exit this screen to start automatic operation.

(8) Operation when line breaking

(8.1) Automatically sewing button after resetting the breaking line



Threading again and press the "Reset" button.

Continue to sew button automatically, and

make sure there is no button under the pressing foot and then press the knee switch to continue.

【Special Attention】

If you want to continue the button sewing, please verify there is no button under the pressing plate, otherwise the needle may snap.

(8.2) Manually sewing button after resetting the breaking line



Threading again and press the "Reset" button.



Switch to "Manual Operation"



Start to operate manually.

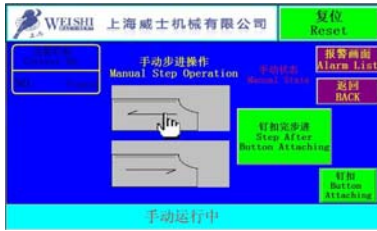

Move to the sewing position and click "Button Attaching" till finish.

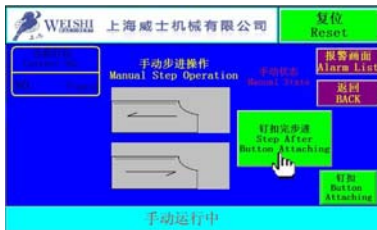
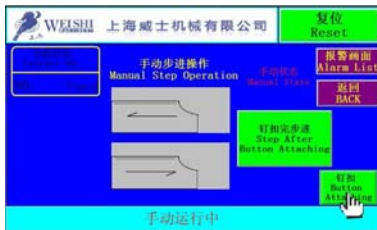

Click the "Step After Button Attaching" till finish material collecting and the servo back to the origin.

the origin.



Click the "Back" button to back to the main interface and start operating automatically.

(9)Operation when stopping

- During the putting cloth process, pressing the "Stop" button will cancel current putting process.
- After starting button sewing, press the "Stop" button, the machine will stop after finishing current button sewing. The specific reset method is the same as 4.8(Operation when line breaking).

① After figuring out why to press the "Stop" button, please press the "Reset" button on the system touch screen to reset.

② If you want to continue the button sewing, please make sure there is no button under the pressing plate and then press the knee switch to continue.

③ If you want to pull out the cloth and stop button sewing, please press the "Emergency Stop" button to cancel the button sewing. Then press the "Reset" button and the green button in the left of the screen to make the servo back to the origin and begin to work again.

【Special Attention】 If you want to continue the button sewing, please verify there is no buttons under the pressing plate, otherwise the needle may snap.

Four. Failure Information Chart

Order Number	Failure information	Reasons and phenomenon for the failure	Processing method
1	Low system air pressure	The main air pressure is insufficient; the system is unable to start.	Check the intake pressure.
2	Line break	The machine is line breaking	Treading again press "Reset" on the operation screen, verify there is no button under the pressing plate. Then press the "Start" button to continue to work.
3	The "Stop" button is pressed during working.	Press the "Stop" button while the machine is working.	Exclude the "Stop" button was pressed, press "Reset" on the operation screen, and make sure that no button is under the pressing plate, press the "Start" button to continue.
4	Servo not back to the original point	Servo not back to the original point	Press "Reset" and back to the origin.
5	Left limit of servo moving	Servo moves to the left limited position, limit switch lights.	Adjust the position of left pressing clip on the slide lever, and press the "Reset" button on the screen and then re-back to the original point
6	Right limit of servo moving	Servo move to the right limited position, limit switch lights.	Adjust the position of right pressing clip on the slide lever, and press the "Reset" button on the screen and then re-back to the original point
7	Communication failure	The communication between the button sewing machine and the touch screen breaks off.	Please check whether the communication cable on the controller of the machine's control system is off.
8	Shuttle insufficient	The spin shuttle thread of the ground thread is insufficient.	Replenish the spin shuttle thread of the ground thread.
9	Servo alarming	The servo controller is alarming.	Cut off the power and restart the machine.
10	The "Reset" button is pressed	The red mushroom head button on the screen is pressed.	Press the red mushroom head button on the screen, and then press the "Reset" button to back to the original point.
11	Button sewing overtime	The button sewing signal doesn't reset normally.	Press the system "Reset" button, and cancel the current button sewing.

12	Manual operation	The system is on manual operation.	Finish one process by manual operation.
13	Length alarm	The total button intervals are exceeding 650mm.	Reset the button interval.
14	Vacuum pump alarm	The thermal protection switch is jump off.	Check whether the vacuum pump motor is working normally.

Five. Electrical Schematic Diagram

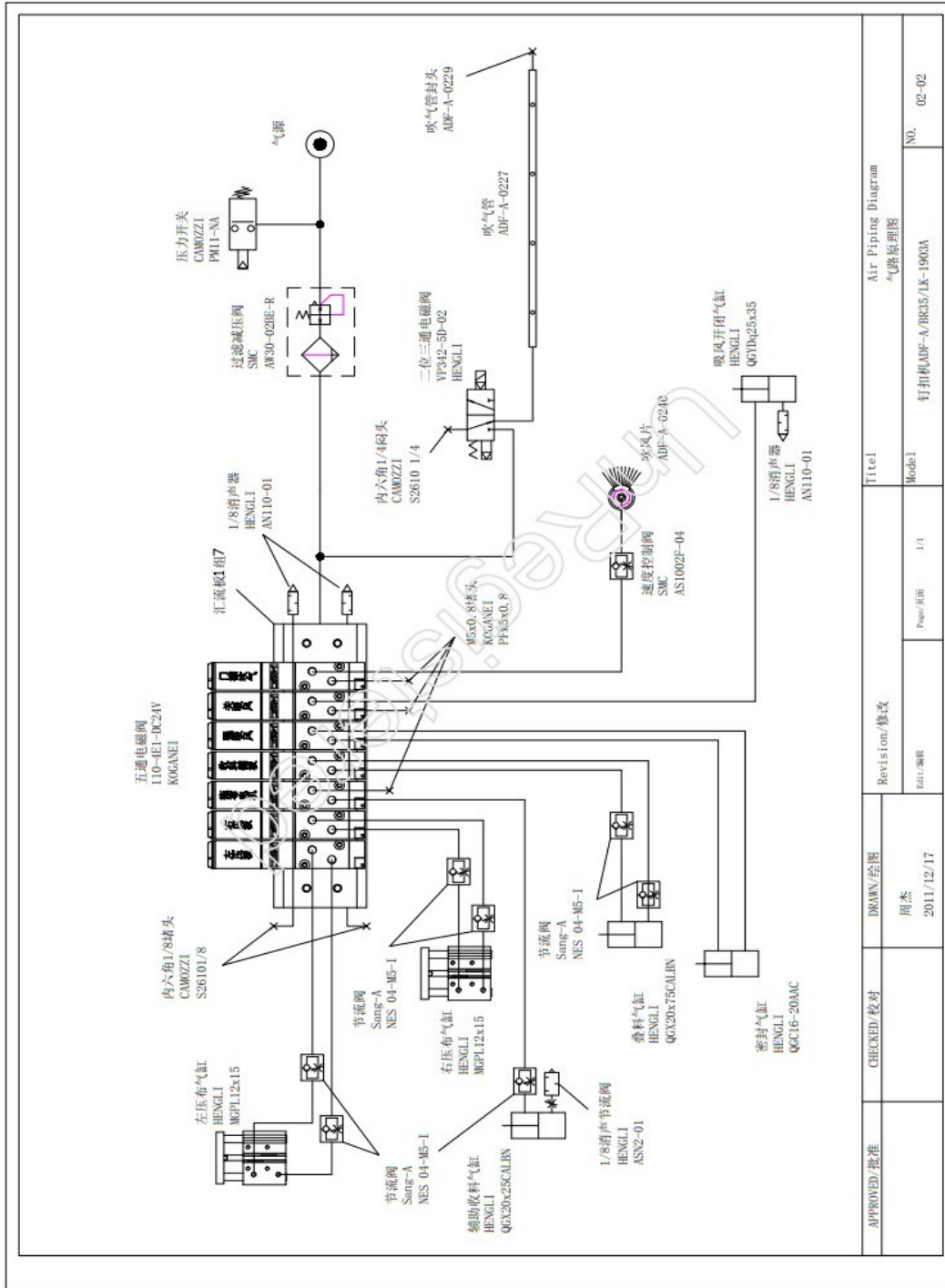

APPROVED/批准	CHECKED/校对	DRAWN/绘图	Revision/修改	Air Piping Diagram	
		周杰 2011/12/17	Edit/编辑	Page/页数	Title
			1/1	Model	气流原理图
				NO.	02-02

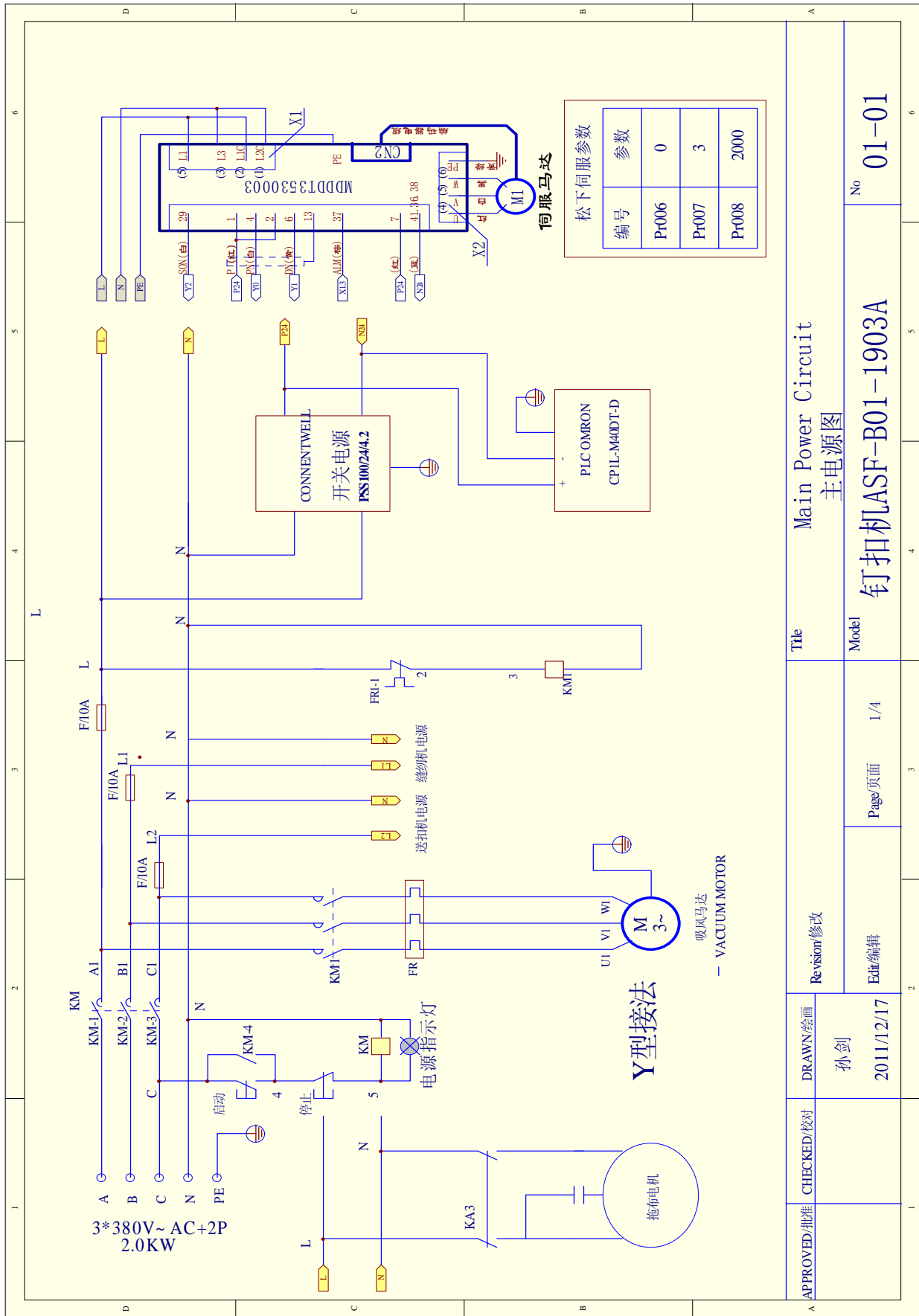

Main Power Circuit
主电源图

Model
钉扣机ASF-B01-1903A

Page/页码
1/4

Revision/修改
孙剑

Editor/编辑
2011/12/17

Checked/校对
Checked/校对

Approved/批准
Approved/批准

No
01-01

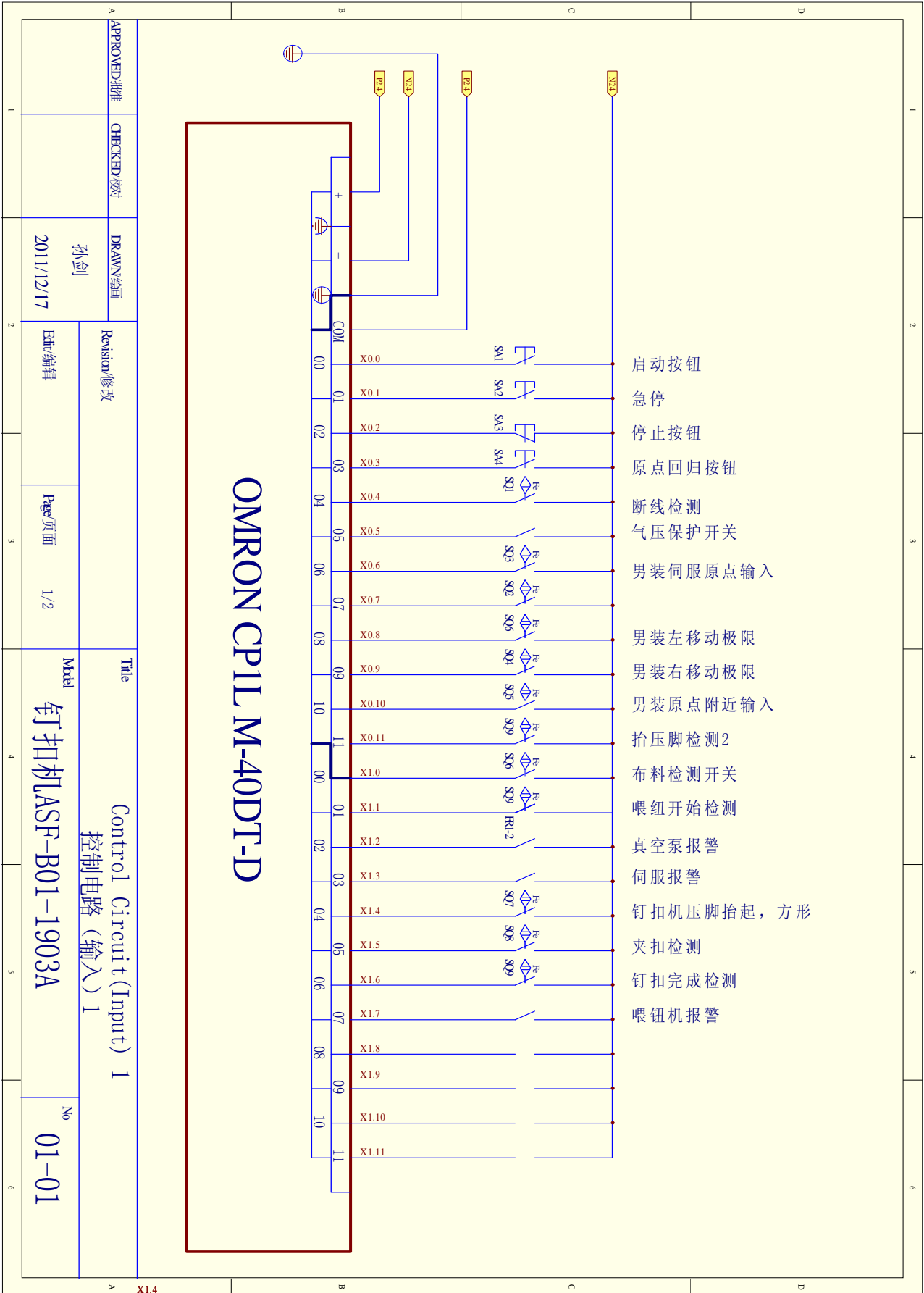

OMRON CP1L M-40DT-D

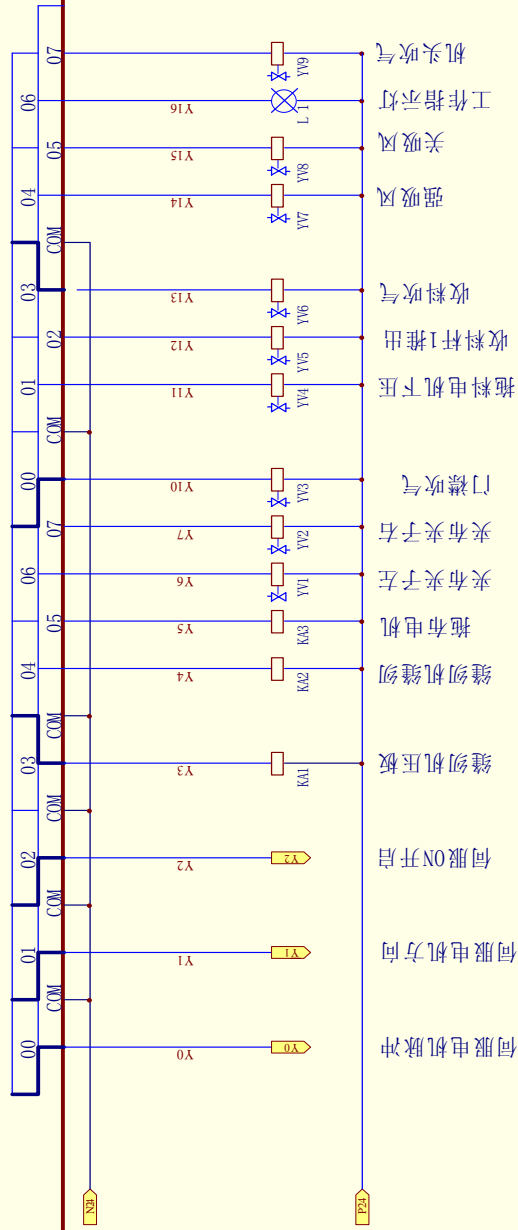

Control Circuit (output) 1
控制电路 (输出) 1

Title

Revision/修改

CHECKED/校对

APPROVED/批准

DRAWN/绘画

孙剑

2011/12/17

Edt/编辑

Page/页面

3/4

Model

钉扣机ASF-B01-1903A

No 01-01



Shanghai Weishi Mechanical

CO. LTD

52#, No.1089, North Qinzhou Road, Shanghai

Tel: 021-64953003

Fax: 021-64957015



※The specification and appearance may be
different from the pictures after modification.