

# 网衬机

Pocket Facing Sewing Machine

(MB2002B-BS-FT7010)

## 使用说明书

Instruction Manual

**常州智谷机电科技有限公司**

CHANGZHOU WISDOM & VALLEY ELECTRICAL TECHNOLOGY CO., LTD

**在使用本设备之前请先阅读本使用说明书**

Please read the operation manual of the touch screen interface before using the device

**请将本使用说明书放在便于查阅的地方保管**

Please keep this operation manual of touch screen interface in convenient place for reference

版本信息/ Version

---

2020.03

**感谢购买 IMB 工业用缝纫机。**

**在使用此机器之前，请仔细阅读以下的说明，这样可以更好地帮到您了解此机器的相关操作。**

**这些说明是根据现行的条例明确阐述了正确的工作方法。**

Thank you for purchasing this industrial sewing machine from IMB

Before using this automatic unit, please read the following instructions, which will help you to

understand how the machine operates.

These instructions illustrate the correct working methods to comply with current regulations.

**在没有得到IMB授权许可的前提下，此说明书的任何部分是不可以被复制或转录的。说明书的内容可能被修改，而不需预先通知。**

No part of this manual may be copied or transcribed without requesting prior authorization from IMB

The contents of this manual may be subject to change without advance notification.

**我们将欣然接受各位提出的改进此说明书的任何建议和指示**

We are happy to receive suggestions and/or indications on ways we could improve this manual.

**本机介绍说明分为三部分，具体请参照《MB2002B 网衬机-使用说明书》、《MB2002B 网衬机-零件手册》、《MB2002B 网衬机-触摸屏界面操作说明》。**

The introduction of this machine is divided into three parts. For details, please refer to 《MB2002B Operation manual》 and 《MB2002B Parts Manual》《MB2002B Touch screen interface operation instructions》

**ENGLISH**

## Content

1、 Basic information of equipment .....	1
2、 Technical parameters of equipment .....	2
3、 Safety precautions .....	3
4、 Key function description .....	5
4.1.Function description of the button .....	5
5、 Debugging method .....	6
5.1.Suction & trimming .....	6
5.2 Turnover plate .....	6
6、 Operating instructions .....	8
6.1. Preparation before operation .....	8
6.2. Operation process description .....	8
6.2.1 Boot device .....	8
6.2.2 Sewing .....	8
6.2.3 Shutdown .....	8
7、 Electrical wiring .....	9
8、 Accessories box details .....	10
9、 Common problems and Solutions .....	11
10、 Daily maintenance requirements .....	11
11、 KNOWLEDGE PRODUCT PROTECTION STATEMENT .....	12

## 1、 Basic information of equipment

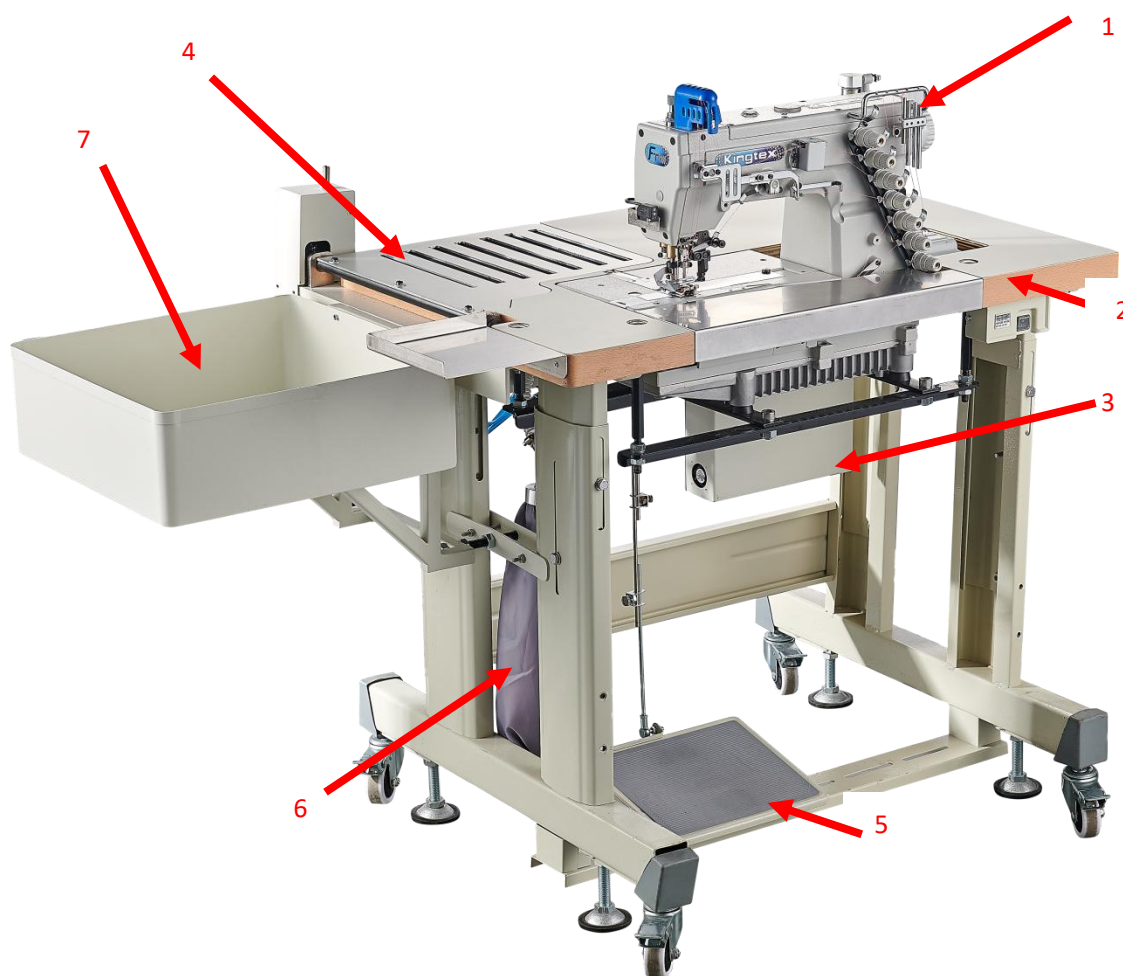



1: BS-FT7010 head; 2: Switch; 3: Control box; 4: Turnover device; 5: Pedal;  
6: Suction; 7: Stacker

## 2、Technical parameters of equipment

MB2002B Pocket Facing Sewing Machine		
1	Machine head	BS-FT7010-0388M
2	Maximum sewing speed/rpm	4500
3	Working voltage /V	220
4	Working air pressure Mpa	0.4-0.5
5	Work efficiency	5s/片
6	Equipment size /mm	1400L×700W×1100H
7	Equipment weight /kg	95

### 3、 Safety precautions

#### Precautions for safe use of automata

 危険	<ol style="list-style-type: none"> <li>1. In order to prevent accidents caused by electric shock, please do not open the cover of the motor electrical box or touch the parts in the electrical box when the power is turned on.</li> </ol>
 注意	<ol style="list-style-type: none"> <li>1. In order to prevent personal injury, please do not operate the machine with the belt guard, finger protector and other safety devices removed</li> <li>2. In order to prevent personal accidents involving the machine, please keep fingers, hair and clothes away from the belt pulley, V-belt and motor during the operation of the sewing machine, and do not put objects on it.</li> <li>3. In order to prevent personal injury, please do not put your finger near the needle when turning on the power or when the sewing machine is running.</li> <li>4. In order to prevent personal injury, please do not put your fingers in the thread take-up rod cover when the sewing machine is running.</li> <li>5. When the sewing machine is running, it turns at a high speed. In order to prevent injury to your hands, please never let your hands near the cloth cutter during operation. In addition, please turn off the power supply when changing the cable.</li> <li>6. In order to prevent personal injury, please take care not to pinch your fingers when the sewing machine moves up and down or returns to its original position.</li> <li>7. When the sewing machine is running, please do not cut off the power or air supply.</li> <li>8. In order to prevent accidents caused by sudden start-up, when the preparatory work is finished and the sewing can be carried out, please remove the cloth guide.</li> <li>9. In order to prevent accidents caused by electric shock, please do not operate the sewing machine when the power ground wire is removed.</li> <li>10. In order to prevent accidents caused by electric shock and damage of electrical parts, please turn off the power switch before plugging in and out the power plug.</li> <li>11. In order to prevent accidents caused by damage of electrical parts, please stop the operation and unplug the power plug for safety during thunder.</li> <li>12. In order to prevent accidents caused by damage to electrical parts, condensation will occur when moving from cold places to warm places, etc., so please turn on the power after the water drops are completely dry.</li> <li>13. Because this product is a precision machine, please pay full attention to the operation, do not splash water and oil on the machine, and do not let the machine drop to impact the machine.</li> <li>14. This machine is a class A industrial machine. If this machine is used in the home environment, the phenomenon of radio interference may occur. At this time, please take appropriate measures to solve the problem of radio interference.</li> </ol>

15. After the power switch is turned off when the stacker acts, the stacker bar acts, so please take care not to pinch fingers, etc.

16. After the power switch is turned off in the presser foot action, the presser foot action, so please pay attention not to pinch fingers, etc.

17. During the folding operation, please be careful not to let the air cylinder clamp the finger when putting the finger in the folding machine.

**\*WARNING:**

✓ Improper operation of the machine may cause personal injury. Please read this instruction carefully and operate it correctly before operation.

✓ Please ventilate the machine before power on.

✓ It is strictly prohibited to open the electric cabinet or the internal parts of the touch screen when it is powered on.

✓ This machine needs to be used after being trained or under the guidance of a special person to ensure the personal safety of the user.



## 4、Key function description

### 4.1. Function description of the button

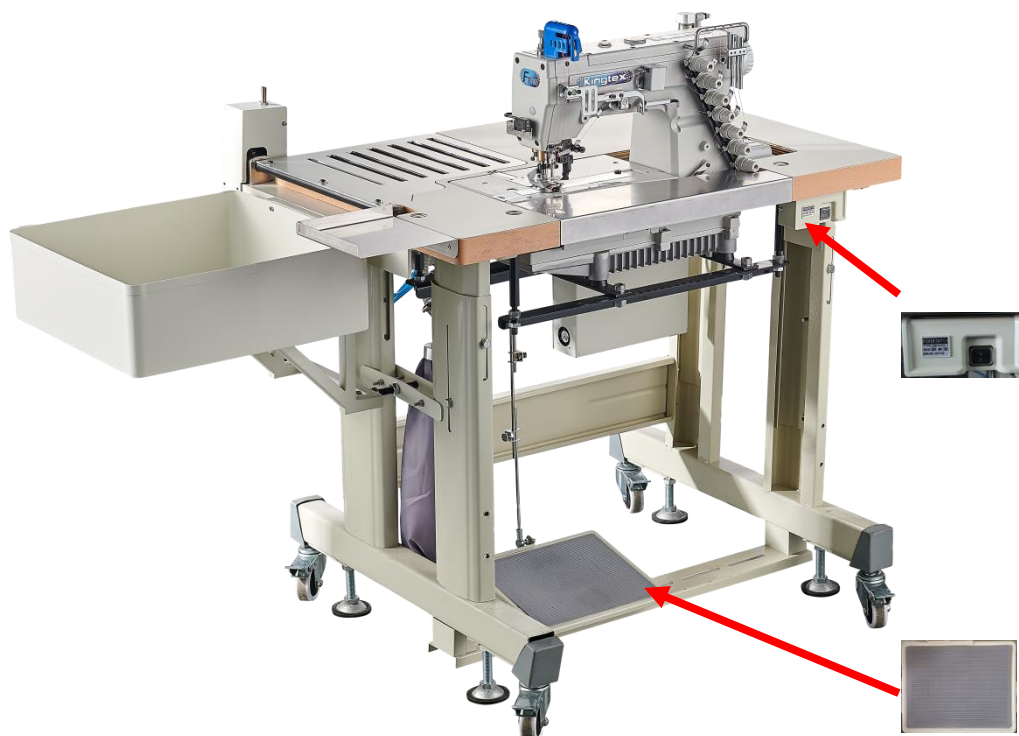

(1) : Power switch: press the power switch to 1, and the equipment is powered on and ventilated.

(2) : Foot pedal: the foot pedal is lifted when the foot pedal is stepped back, and sewed when the foot pedal is stepped forward. The motor speed increases with the stepping force.

## 5、Debugging method

### 5.1. Suction & trimming

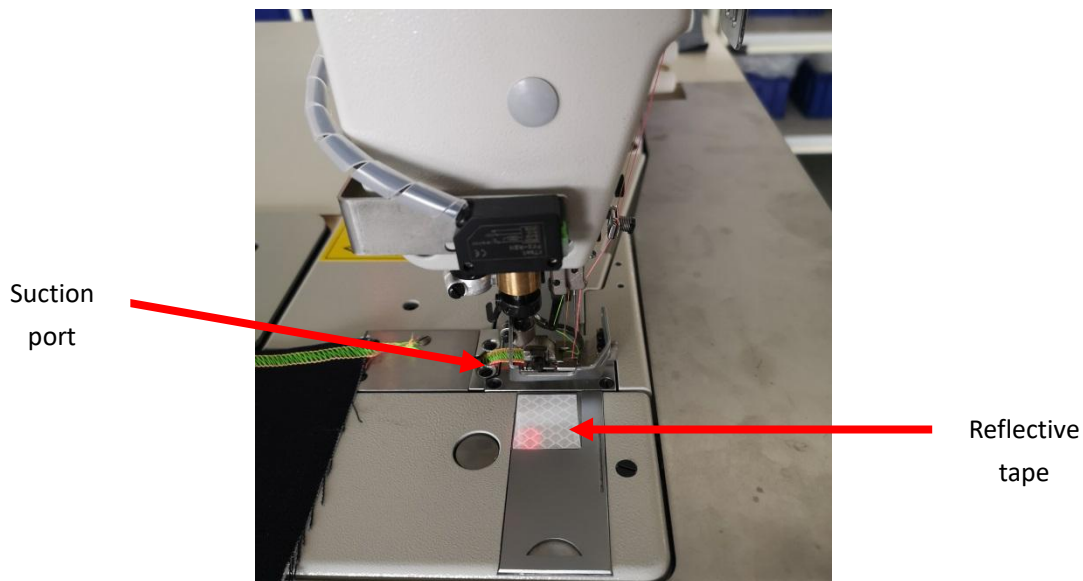

(1) Suction: after starting the machine, step forward on 4.1 – (2) foot pedal to start suction. When the cloth covers the reflective tape, the suction stops after a short delay. When the reflective tape is exposed to the suction, the foot pedal releases to stop suction.

(2) Trimming: The machine head starts to sew and the scissors start to cut the thread. The machine head stops the scissors and they run synchronously. It should be noted that after sewing, the fabric should be pushed forward for a certain distance, and the thread should be tied to the air inlet

### 5.2 Turnover plate

(1) Turnover conditions: the cloth leaves the reflective paper, step on the foot pedal to release the turnover.

(2) Flap swing speed adjustment: The flap is directly driven by the air cylinder. The speed of flap swing can be adjusted by adjusting the speed regulating joint of the air cylinder. The speed should be moderate. Too fast will cause the cloth to fly out or make abnormal noise.

a. Speed up joint: control the feeding speed of turning plate, speed up the left-hand speed regulating valve and slow down the right-hand speed regulating valve.

b. Speed regulating joint: control the recovery speed of the flap, speed up the left-hand speed regulating valve and slow down the right-hand speed regulating valve.

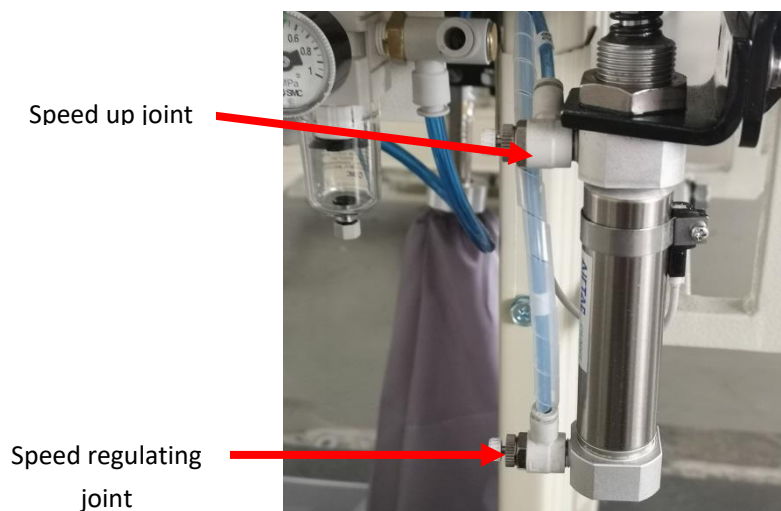

c. Precautions: to ensure that the cloth falls flat in the receiving box, the cloth shall be manually delivered to the top of the turnover plate after sewing, as shown in the figure below; keep a distance from the turnover plate working area during the sewing process to avoid accidental injury.

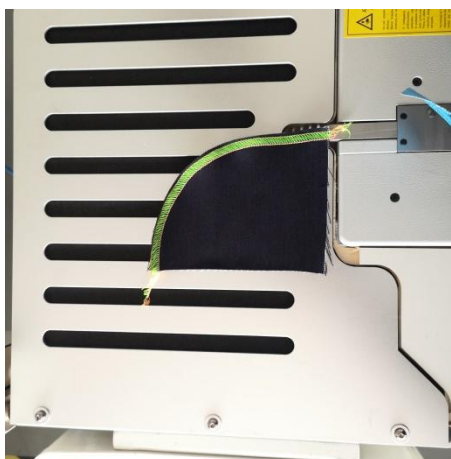

## **6、 Operating instructions**

### **6.1. Preparation before operation**

√ the machine head shall be in the stop state during the inspection by the operator

√ Check whether the table sponge is intact

√ Check whether the sewing thread has been correctly put on

√ Check whether the needle has been installed

√ Clean the sundries on the machine table to ensure that there are no sundries hindering the operation of the machine

√ Check the pressure of the barometer to make it meet the requirements of the machine

### **6.2. Operation process description**

#### **6.2.1 Boot device**

4.1- (1) Press the power switch to 1, and the equipment is powered on and ventilated.

#### **6.2.2 Sewing**

Step back on the 4.1 - (2) pedal, lift the presser foot, place the cloth according to the garment process, step forward on the pedal, slowly speed up, move the cloth, sew until the thread cutting is completed, quickly place the cloth on the flap, release the pedal, and the cloth will be automatically placed in the discharge box.

#### **6.2.3 Shutdown**

After the operation, press the 4.1 - (1) power switch until the 0, device is shut down.

## 7、Electrical wiring

### 7.1. Signal board:

2002B	PORT	Specifications	Reset status
Magnet switch	IN1	3P	OFF
Switch	IN2	3P	OFF
Solenoid valve	OT1	2P	OFF
Dust valve	OT2	2P	OFF
Pedal 1	INA1	3P	OFF
Pedal 2	J101	6P	OFF

## 8、Accessories box details

NO.	ITEM		QTY
1	《Operation manual》		1
2	《Parts Manual》		1
3	《Touch screen interface operation instructions》		1
4	Head attachment		1

## 9、Common problems and Solutions

9.1. For common problems and solutions, please refer to the handpiece manual

## 10、Daily maintenance requirements

10.1. See the following table for the list and requirements of equipment maintenance

10.2. Refer to bs-ft7010-0388m for other maintenance requirements

NO	Project	Frequency				Requirement
		Daily	Weekly	Monthly	Half year	
1	Dust removal	√				Remove dust from equipment surface and parts
2	Cleaning up oil pollution		√			Clean the greasy dirt on the table board, needle board and shuttle core
3	Pressboard sponge			√		Check whether the sponge is worn or deformed and replace it if it is damaged
4	Tracheal interface			√		The air pipe interface is tight without air leakage
5	Oil			√		The head oil quantity shall not be lower than the warning line
6	Bobbin			√		Check if the bobbin is scratched
7	Sensor				√	Check if the sensitivity is accurate and if the position changes
8	Slider				√	Check slide lubrication and add lubricant if necessary
9	Electric control box				√	Cooling fan runs normally, clean up the dust in time

## **11、KNOWLEDGE PRODUCT PROTECTION STATEMENT**

MB2002B was designed by Changzhou wisdom & valley Electric Technology Co., Ltd.。 The intellectual property rights of this achievement belong to Changzhou wisdom & valley Electric Technology Co., Ltd. and are protected by national intellectual property laws and regulations. Without the written permission of the right holder, the patented technology of the achievement shall not be implemented, and the information related to the achievement shall not be copied, sold or disseminated through the network. For any illegal infringement, Changzhou wisdom & valley Electric Technology Co., Ltd. will pursue its legal responsibility according to law.