

送扣装置

Button feeder

(MB6002C)

使用说明书

Instruction Manual

常州智谷机电科技有限公司

CHANGZHOU WISDOM & VALLEY ELECTRICAL TECHNOLOGY CO., LTD

在使用本设备之前请先阅读本使用说明书。

Please read the operation manual of the touch screen interface before using the device

请将本使用说明书放在便于查阅的地方保管

Please keep this operation manual of touch screen interface in convenient place for reference

版本信息/Version

2020.01

感谢购买 IMB 工业用缝纫机。

在使用此机器之前，请仔细阅读以下的说明，这样可以更好地帮到您了解此机器的相关操作。

这些说明是根据现行的条例明确阐述了正确的工作方法。

Thank you for purchasing this industrial sewing machine from IMB

Before using this automatic unit, please read the following instructions, which will help you to

understand how the machine operates.

These instructions illustrate the correct working methods to comply with current regulations.

在没有得到IMB授权许可的前提下，此说明书的任何部分是不可以被复制或转录的。说明书的内容可能被修改，而不需预先通知。

No part of this manual may be copied or transcribed without requesting prior authorization from IMB

The contents of this manual may be subject to change without advance notification.

我们将欣然接受各位提出的改进此说明书的任何建议和指示

We are happy to receive suggestions and/or indications on ways we could improve this manual.

本机介绍说明分为三部分，具体请参照《MB6002C-使用说明书》、《MB6002C-零件手册》、《MB6002C-触摸屏界面操作说明》。

The introduction of this machine is divided into three parts. For details, please refer to 《MB6002C Operation manual》 and 《MB6002C Parts Manual》 《MB6002C Touch screen interface operation instructions》

ENGLISH

Catalog

1、 Basic information.....	1
2、 Technical parameter.....	2
3、 Safety precautions.....	3
4、 Key function.....	5
4.1 .Key function description.....	5
4.2 .Description of shaking table switch.....	5
5、 Operating instructions.....	6
5.1. Preparation before operation.....	6
5.2. Description of operation process.....	6
6、 Debugging method.....	8
6.1. Change button operation.....	8
7、 Electrical wiring.....	13
8、 Optional devices.....	14
9、 Accessory box details.....	14
10、 Common problems and Solutions.....	15
11、 Daily maintenance requirements.....	16
12、 Knowledge product protection statement.....	16

1、 Basic information

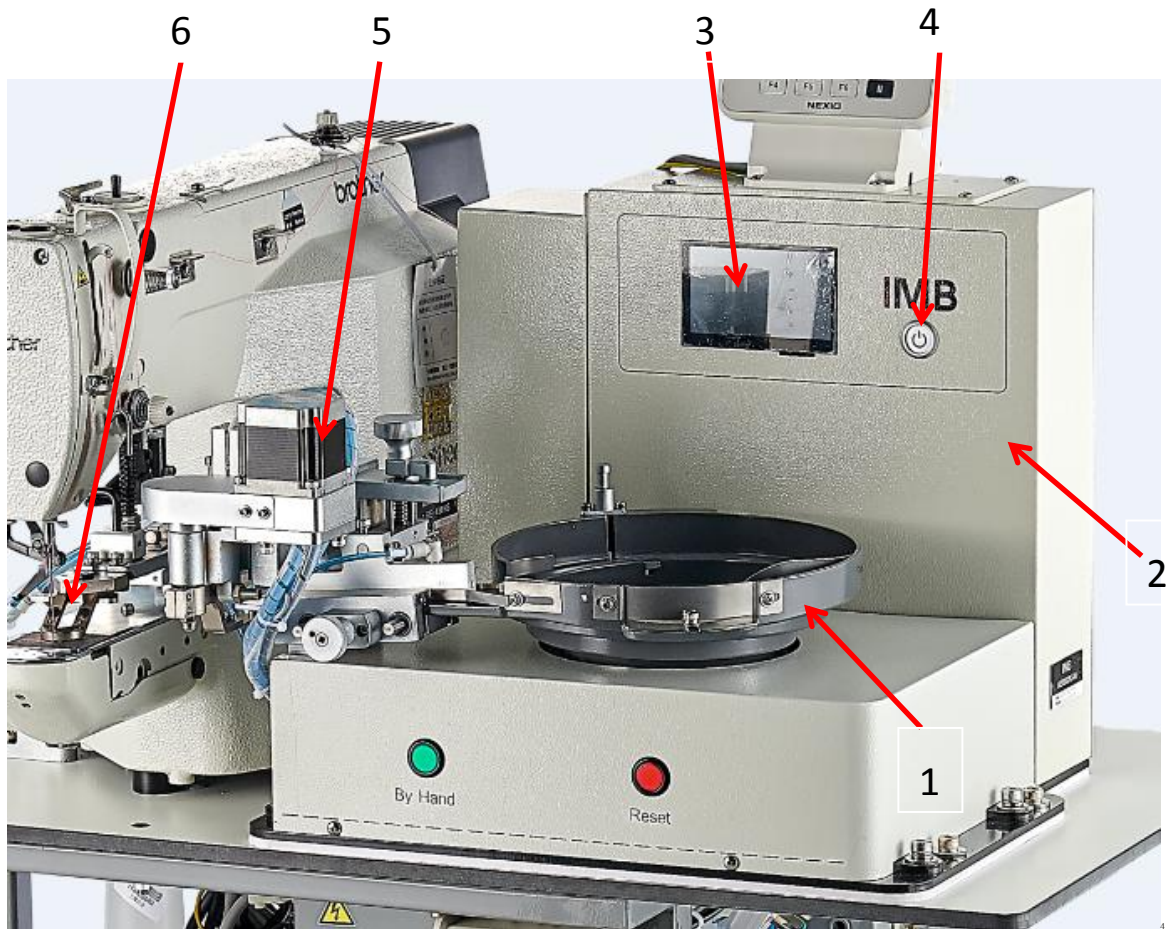

1: Vibrating disc;
4: power switch;

2: Control box;
5: Button feeding device;



3: Touch screen;
6: Clip;

2、 Technical parameter

MB6002C Button feeder				
1	Machine head	brother/juki/Jack/Zoje etc.		
2	Voltage /V	220		
3	Pressure /Mpa	0.5		
4	Rated power	65W		
5	Efficiency	13000-15000pcs/8h		
6	Size/mm	460L×420W×375H		
7	Weight/kg	35		
8	Button selection	2 Holes、 4 Holes (3 Holes、 5 Holes optional)		
9	Button diameter /mm	9-20		
10	Button thickness /mm	1.8-4		
	Claw style	A	B	C
11		2.2 ± 0.01	$\varphi 6_0^{+0.02}$	$\varphi 1.0_{-0.01}^0$
		2.4 ± 0.01	$\varphi 6_0^{+0.02}$	$\varphi 1.0_{-0.01}^0$
		2.6 ± 0.01	$\varphi 6_0^{+0.02}$	$\varphi 1.2_{-0.01}^0$
		2.8 ± 0.01	$\varphi 6_0^{+0.02}$	$\varphi 1.2_{-0.01}^0$
		3.0 ± 0.01	$\varphi 6_0^{+0.02}$	$\varphi 1.2_{-0.01}^0$
		3.6 ± 0.01	$\varphi 8_0^{+0.02}$	$\varphi 1.2_{-0.01}^0$
		3.2 ± 0.01	$\varphi 6_0^{+0.02}$	$\varphi 1.2_{-0.01}^0$
		4.0 ± 0.01	$\varphi 8_0^{+0.02}$	$\varphi 1.2_{-0.01}^0$
12		2.0 ± 0.01	$\varphi 6_0^{+0.02}$	$\varphi 1.0_{-0.01}^0$
		2.2 ± 0.01	$\varphi 6_0^{+0.02}$	$\varphi 1.0_{-0.01}^0$
		2.4 ± 0.01	$\varphi 6_0^{+0.02}$	$\varphi 1.0_{-0.01}^0$
		2.6 ± 0.01	$\varphi 6_0^{+0.02}$	$\varphi 1.2_{-0.01}^0$
		2.8 ± 0.01	$\varphi 6_0^{+0.02}$	$\varphi 1.2_{-0.01}^0$
		3.0 ± 0.01	$\varphi 6_0^{+0.02}$	$\varphi 1.2_{-0.01}^0$
		3.2 ± 0.01	$\varphi 6_0^{+0.02}$	$\varphi 1.2_{-0.01}^0$
		3.6 ± 0.01	$\varphi 8_0^{+0.02}$	$\varphi 1.2_{-0.01}^0$
		4.0 ± 0.01	$\varphi 8_0^{+0.02}$	$\varphi 1.2_{-0.01}^0$

3、Safety precautions

Considerations for safe use of automata

 危険	<p>1. In order to prevent accidents caused by electric shock, please do not open the cover of the electrical box of the motor or touch the parts in the electrical box when the power is connected.</p>
 注意	<p>1. In order to prevent personal injury, please do not operate the machine in the state of removing the belt guard, finger protector and other safety devices.</p> <p>2. In order to avoid being involved in the machine's personal accident, please do not let your fingers, hair, clothes near the pulley, v-belt, motor, and do not put items on it during the operation of the sewing machine.</p> <p>3. To prevent personal injury, please do not put your finger near the needle when turning on the power or running the machine.</p> <p>4. In order to prevent personal injury, please do not put your fingers in the wire pole guard during the operation of the sewing machine.</p> <p>5. When the machine is running, it turns at a high speed. To prevent damage to the hand, never let the hand near the cutter during operation. In addition, when changing the cable, please be sure to turn off the power.</p> <p>6. In order to prevent personal injury, please be careful not to pinch your fingers when the machine moves up and down or when you return to the original position.</p> <p>7. Please do not cut off the power or air supply while the machine is running.</p> <p>8. In order to prevent accidents caused by sudden starting, please remove the cloth guide when the preparation work is finished and the sewing state is reached.</p> <p>9. In order to prevent accidents caused by electric shock, please do not operate the sewing machine when the ground wire of the power supply is removed.</p> <p>10. In order to prevent accidents caused by electric shock and damage to electrical parts, be sure to turn off the power switch before inserting or unplugging the power plug.</p> <p>11. In order to prevent accidents caused by damage of electrical parts, please stop the operation for safety when it thunders and pull the power plug.</p> <p>12. In order to prevent accidents caused by damage to electrical parts, condensation will occur when moving from a cold place to a warm place immediately, so please wait until the water drops dry before switching on the power.</p> <p>13. As this product is a precision machine, please pay full attention to it during operation, do not splash water or oil on the machine, and do not let the machine fall and give the machine impact.</p> <p>This machine is A class A industrial machine. The use of this machine in the home environment may cause the phenomenon of radio interference. At this point, please take appropriate measures to solve the problem of radio interference.</p> <p>15. After the power switch is turned off when the accumulator moves, the accumulator lever moves, so please be careful not to clip your finger, etc.</p> <p>16. When the power switch is turned off during the foot press action, please</p>

be careful not to pinch your fingers.

17. During folding operation, please be careful not to clip the cylinder to your finger when putting your finger into the folding machine.

*** important safety information:**

- ✓ improper operation of the machine may cause personal injury. Please read this instruction carefully and operate correctly before operation.
- ✓ Please ventilate the machine before it is officially powered on.
- ✓ do not turn on the internal parts of the electric cabinet or touch screen while the power is on.
- ✓ this machine should be used after receiving training or under special instruction to ensure the safety of the user.

4、Key function

4.1 .Key function description

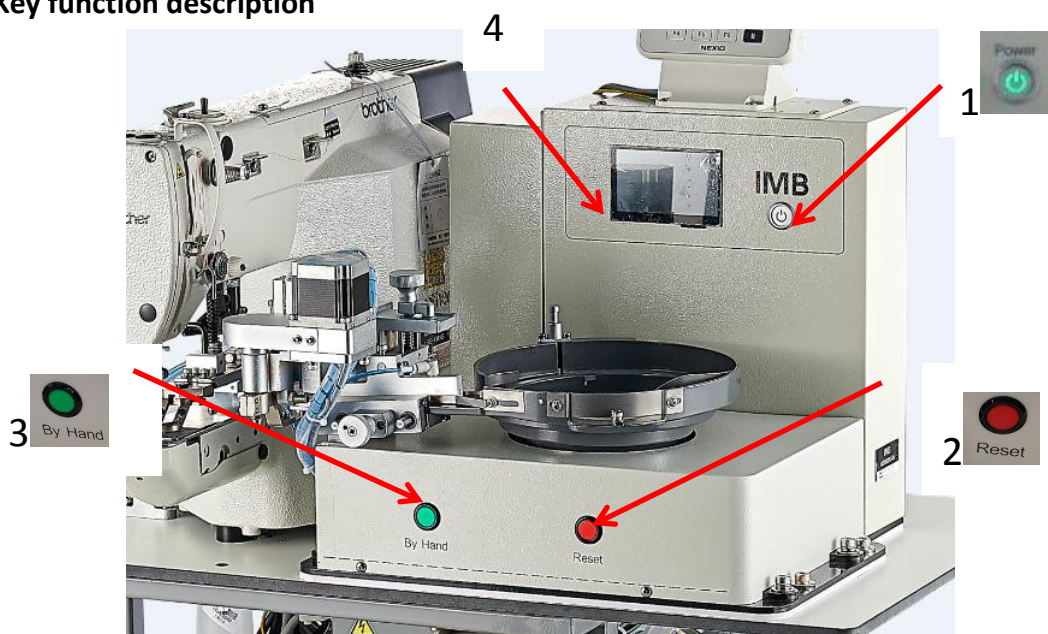

(1) : Power switch—after pressing the device is energized, the vibrating disk starts to work.

(2) : Reset switch—The device is reset after pressing the switch.

(3) : Manual button --- press to feed the button.

(4) : Device touch screen—display setting parameters.

a Boot screen:



b Menu



4.2 .Description of shaking table switch

振动设置

Press "vibration setting" in 4.1 (4) - B menu interface Enter the following interface.

Adjust the frequency and amplitude of the vibration table through the up and down arrows, and adjust it to the continuous feeding of the vibrating plate.

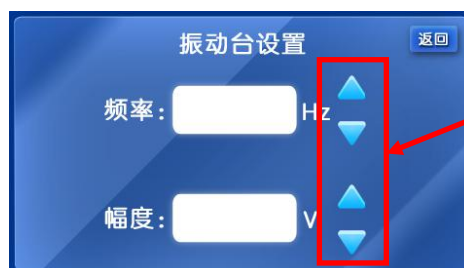

5、 Operating instructions

5.1. Preparation before operation

- ✓ When the operator checks, the machine head should be in the stop state
- ✓ Check whether the feeding claw is intact
- ✓ Check that the stitches have been correctly fitted
- ✓ Check whether the needle has been installed
- ✓ Clean up the sundries on the machine table to ensure that there are no sundries hindering the operation of the machine
- ✓ Check the pressure of the barometer to make it meet the requirements of the machine

5.2. Description of operation process

5.2.1 Start the device

Step 1: power on and ventilate the corresponding adapter head;

Step 2: Press  then power on the device. The button indicator turns green, and the 4.1 (5) a welcome interface is displayed on the touch screen. Select the language to enter the 4.1 (5) B menu interface.

5.2.2 Reset operation

The device will reset automatically when the sewing machine is reset

5.2.3 Cloth placement

Place the piece to be buttoned under the needle and tighten.



5.2.4 Automatic sewing

① Continuous feeding of the same button: press the foot switch, and the machine will sew the button automatically.

③ Intermittent button feeding of different buttons: click "function selection" in 4.1 (4) B menu

功能选择

interface. The following interface will pop up. Click "intermittent button feeding" to set the parameters of intermittent buckle feeding. In the continuous thread feeding, the number of feeding by the vibrating plate is input, and the number of manual mending is input in the intermittent feeding.

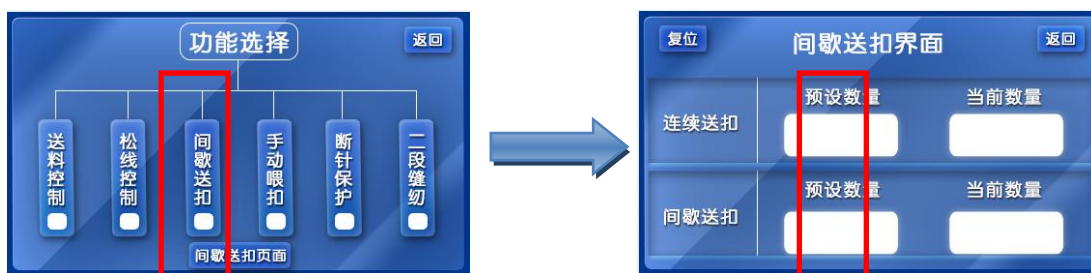

For example: the continuous button feeding setting is 3, and the intermittent button feeding setting is 1. The manipulator will swing out after taking the button in the vibration disk for three times, and then manually put in different buttons and send them into the button clamp, which will be repeated in turn.

5.2.5 Shutdown

After operation, press the shutdown button in 4.1 (1) to shut down the button feeding device

6、 Debugging method

6.1. Change button operation

6.1.1、 button exchange

Empty all buttons on the vibration plate and track and replace with the required buttons。

6.1.2 Claw exchange

Select the appropriate button feeding claw according to the button size (see Figure C below), and replace the button feeding claw by removing the screw in the drawing (see Figure D below)。

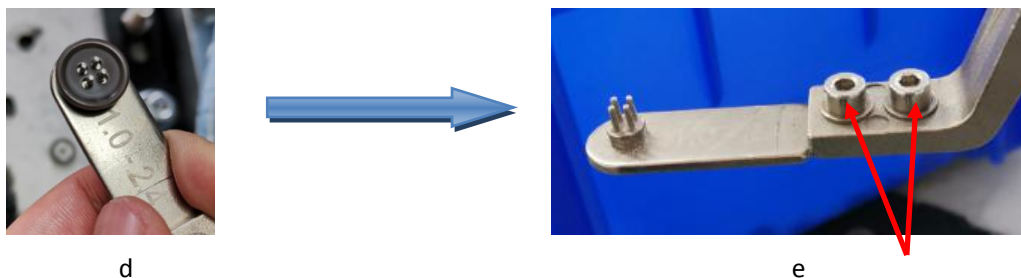

6.1.3 Thickness measurement adjustment

Pull up the handle, take a button to be used and place it under the thickness measuring plate, and then release the handle (see Figure e below)。

Note: please do not place the buttons in the opposite direction, as this may cause the measured thickness to be too small (see Figure F below)。

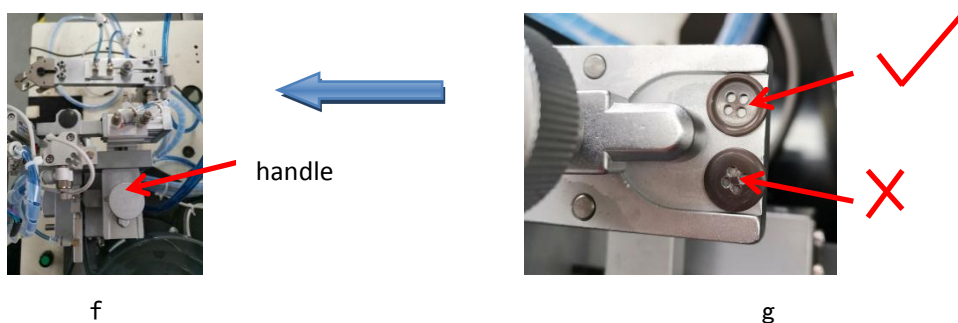

6.1.4 Feed track adjustment

Put the button flat on the transmission track, and adjust its width by hand wheel, which is about 1-2mm larger than the diameter of the button (see Figure g below)。

Adjust the angle of the blowing pressure plate by tightening the two screws in the figure, so that the button can pass through the channel smoothly (see Figure h below)。

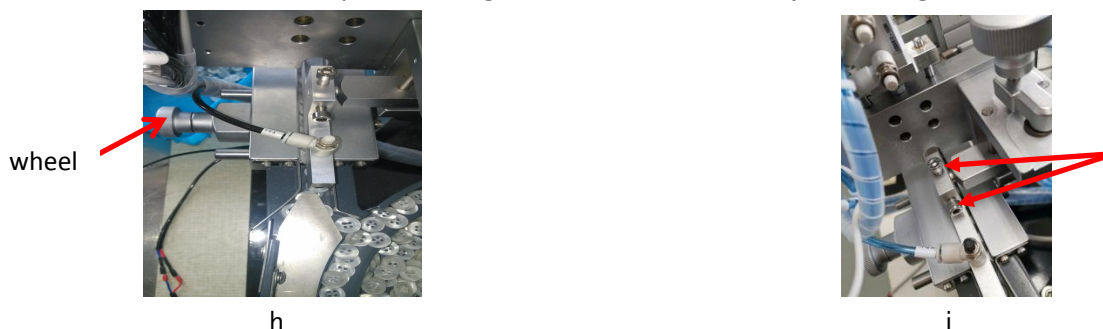

6.1.5 Claw adjustment

1) 、 Open system test:

4.1 (5) b In the menu interface, press "system test"  :



j

2) 、 Adjusting the claw:

① In the system test interface, press the mechanical arm to send the buckle and adjust it to the button taking position. Press the mechanical arm up and down to the highest position.

② Through the screw in the figure J below, use the button feeding claw to install the waist hole for left and right adjustment, so that the button feeding claw boss is relative to the left and right joints of the card slot.

③ Adjust the front and rear of the feed claw through the screw in Figure K below to make it face the upper cylinder rod.



k

Rod



l

6.1.6 Baffle adjustment

① In the "system test" interface, press the baffle to expand and extend.

② After loosening the two supporting screws as shown in Figure L, adjust the screw in Figure m to make the gap between the protruding baffle plate and the button about 0.5mm.

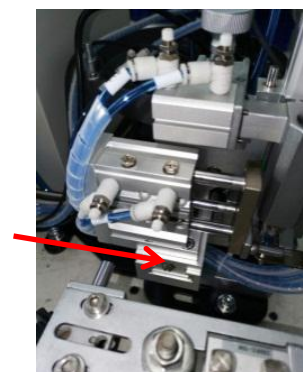

m

n

6.1.7 Vibration disc adjustment

1) 、 Adjustment of button feeding frequency:

④ Turn on the power button and the power indicator will be on;

⑤ 4.1 (2) "adjusting knob" is used to adjust the vibration frequency of feeding plate, and the vibration disc can supply buttons continuously, so that the track is full of buttons;

③ The reliability of button conveying is adjusted by several screen pieces on the vibrating plate.

2) 、 Positive and negative button adjustment: through the left and right of the serrated screen piece, the positive and negative screening effect through the button can be adjusted.



3) 、 Adjustment of positive and negative buttons of special buttons: through the height adjustment of screen piece, the screening effect of positive and negative buttons on large arc bottom can be adjusted.



4) 、 、 Button feeding adjustment: adjust the thickness of the button through two screen piece adjustment, and exclude the button stack.



6.1.8 Head clip replacement

1) 、 Clip installation:

Remove the original clip part and replace it with mb6002b device (see Figure o below)。

Fix the mounting screw tightly to ensure that it is movable up and down without clamping.

After installation, adjust the position of the button.



o



p

2) 、 Clip adjustment:

If the needle and clip are not in the right position, adjust the front, rear, left and right positions of the clip through the M5 screw above, and each must be tied in the center of the button hole (see Figure Q below)



q



r

6.1.9 Alignment adjustment of feeding claw and button clamp

Install the button feeder according to the picture sequence and adjust the position so that the feeding position of the feeding claw coincides with that of the button clamp.

***Pay attention to the position of table top drilling: the position should not be too much, and the error range is (- 8mm ~ 8mm).**

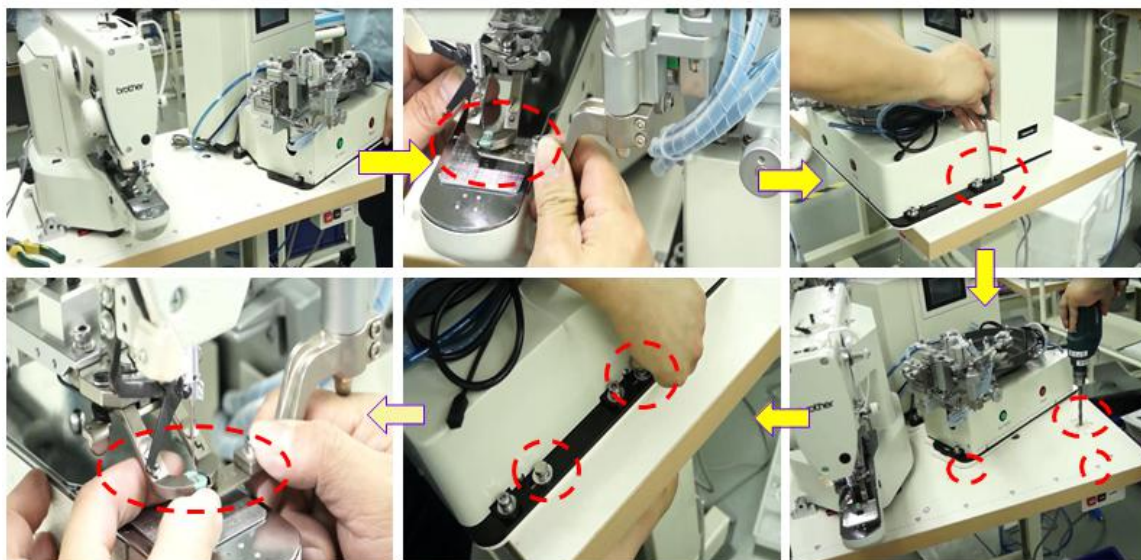

6.1.10 Adjustment of limit

1) 、 **Function of x2 sensor**: The function of x2 sensor is that it can't run the next step without buckle. If there is no buckle in the button feeding slot, X2 sensor will be on and alarm E01 will be displayed. If there is button in the button feeding slot, the machine will run normally.

2) 、 **X2 sensor adjustment**: When the column is rotated and pressed down, the X2 sensor

without buckle in the buckle groove is on, and the sensor x2 with buckle in the button feeding groove is not on.

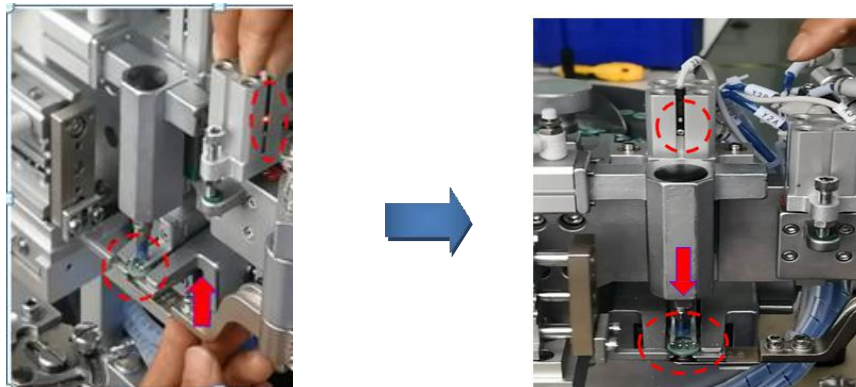

X2

3) 、 **Function of x3 sensor**: The function of X3 sensor is that if the manipulator does not catch the buckle, the inductor is not on and can not run in the next step. If the manipulator does not catch the buckle, the X3 sensor will not light up and alarm E02.

4) 、 **X3 sensor adjustment**: When the column rotates and presses the manipulator up to the highest point, X3 sensor is on, sensor is on early fly button, and it shows no buckle too late.

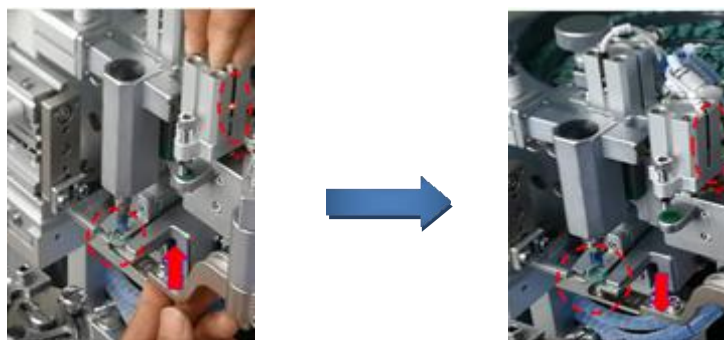

X3

5) 、 **Proximity switch action**: The function of the proximity switch is to fix the starting point of the claw and ensure that the claw is sent to the button clip.

6) 、 **Proximity switch adjustment**: Adjust the front and rear position by proximity switch thread.

Motor type feeding claw in the process of rotating feeding, touching objects will trigger action stop, which can effectively protect the device and personal safety.

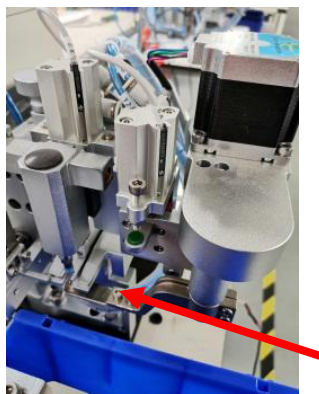

7、Electrical wiring

7.1. Motor board control:

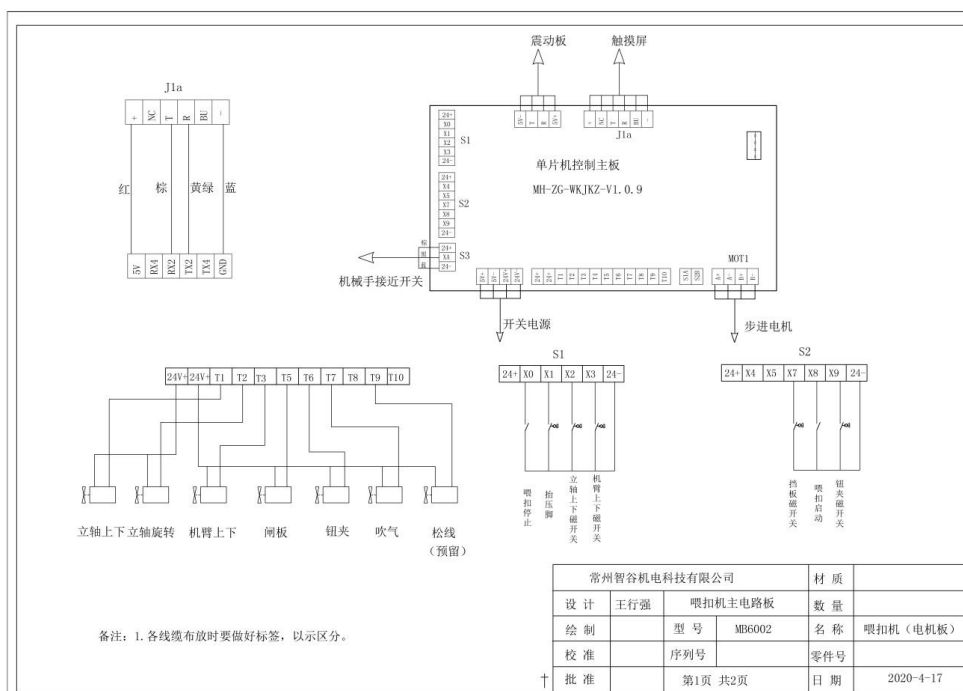

7.2. Motor board pneumatic control:

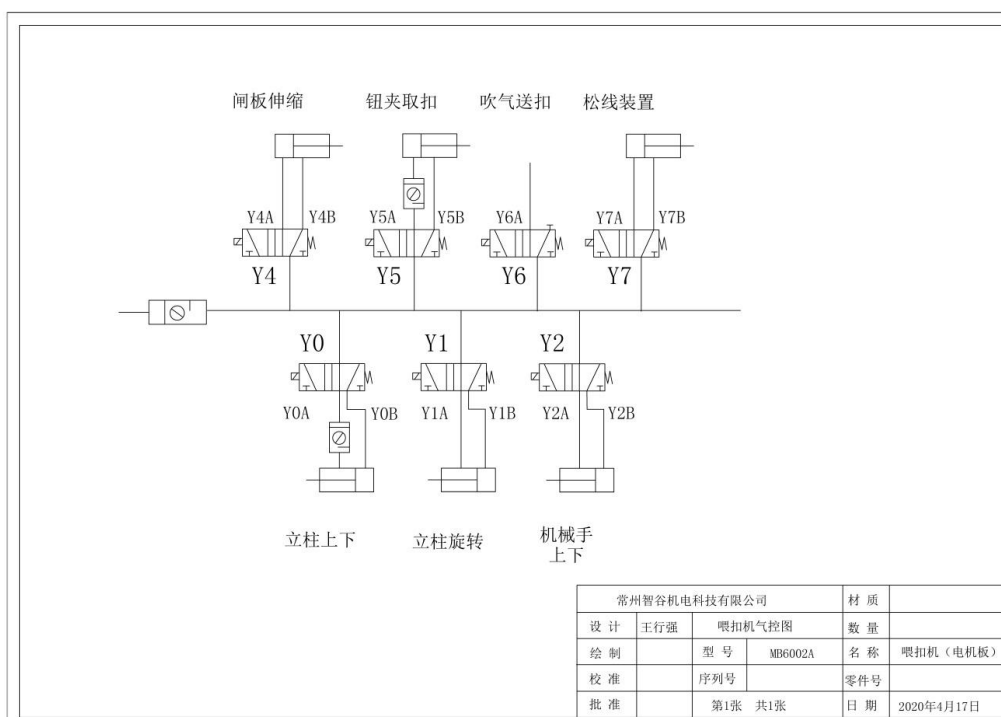

8、 Optional devices

8.1. Thread loosening mechanism: if the manufacturer with winding requirements often needs a longer button handle, the thread loosening function can be turned on (see the thread loosening function switch on the touch screen) and the thread loosening starts to work.



9、 Accessory box details

NO	ITEM	SIZE	QTY
1	《instruction manual》		1
2	《Parts manual》		1
3	《Operation instructions of touch screen interface》		1
4	screwdriver	5*300mm	1
5	spanner	1.5--6mm	1
6	Claw		11

10、 Common problems and Solutions

10.1. Common problems and solutions are shown in the table below

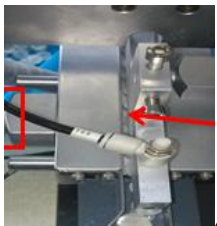
10.2. For other page problems, please refer to mb6002b – touch screen interface operation instructions》

phenomenon	picture	Cause analysis	Solutions
Blocking of feeding track		<ol style="list-style-type: none"> 1、 The thickness measuring plate is too high or too low 2、Over buckle channel is too tight or platform delivery 3、 Tilting of blowing plate 	<ol style="list-style-type: none"> 1、 Adjust the height of thickness measuring plate 2、 Adjust the width of the channel 3、 Adjust the angle of blowing pressure plate
Poor gripping of feeding claw		<ol style="list-style-type: none"> 1、 Poor contact between the end of the hose and the buckle 2、 Blanking hole buckle causes blockage 3、 The ram is not in the right position from the button 	<ol style="list-style-type: none"> 1、 Check and adjust whether the length of the hose is appropriate and whether the plane of the head of the hose is flat 2、 Check for snap 3、 Adjust ram position
Vibration disk does not work		<ol style="list-style-type: none"> 1、 The speed of knob is too low 2、 Open circuit 	<ol style="list-style-type: none"> 1、 Vibration disk speed control 2、 Check the wiring
Poor screening material of vibrating plate		The position of the inserting piece of the vibrating plate is not correct	Check and adjust the position of the sieve plate on the vibrating plate.
Interruption of feeding process		<ol style="list-style-type: none"> 1、 Position deviation of magnetic switch 2、 Feeding block 	<ol style="list-style-type: none"> 1、 Check whether the magnetic switch position and light are abnormal. 2、 Check the abnormal position during feeding.

11、 Daily maintenance requirements

11.1. Equipment maintenance list and requirements are shown in the table below

11.2. For other maintenance requirements of handpiece, please refer to the manual of optional handpiece

NO	Projects	Frequency				Requirement
		Daily	Weekly	Monthly	Half year	
1	Clean up the dust	√				Remove dust on equipment surface and parts
2	Clean up the oil		√			Clean the oil stains on the table board, needle plate and shuttle core
3	Claw			√		Keep the claw free from deformation and corrosion
4	Clip			√		Check that the screws are tight and keep the parts free from shaking
5	Trachea interface			√		The air pipe interface is tight without air leakage
6	sensor				√	Check whether the sensitivity is accurate and whether the position changes
7	Sliding parts				√	Check lubrication of sliding parts and add lubricant if necessary
8	Electric control box				√	The cooling fan runs normally and the dust should be cleaned up in time

12、 Knowledge product protection statement

MB6002B Button feeder was designed by Changzhou wisdom & valley Electric Technology Co., Ltd. . The intellectual property rights of this achievement belong to Changzhou wisdom & valley Electric Technology Co., Ltd. and are protected by national intellectual property laws and regulations. Without the written permission of the right holder, the patented technology of the achievement shall not be implemented, and the information related to the achievement shall not be copied, sold or disseminated through the network. For any illegal infringement, Changzhou wisdom & valley Electric Technology Co., Ltd. will pursue its legal responsibility according to law