

MC 18Z-57
MC 18C-57

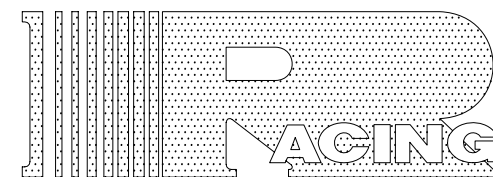

使用手冊
MANUAL

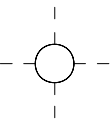

1. 燈亮
1. LIGHT ON



2. 操作順序
2. OPERATION STEP



3. 按此鍵表計數增加
3. PRESS FOR COUNTER INCREASE



4. 按此鍵表計數減少
4. PRESS FOR COUNTER DECREASE

控制盒面板說明

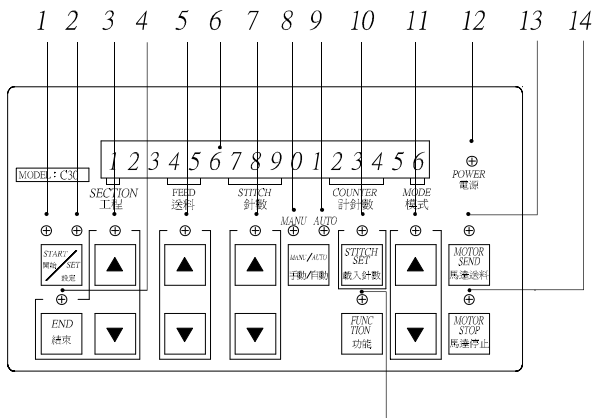

控制盒用途說明

15

- 1 開始(循環開關): 回復啓始狀態
- 2 設定(循環開關): 進入設定修改狀態
- 3 工程: 設定工程段數1~9段
- 4 結束: 設定工程結束。
- 5 送料: 每針送料長度設定00~99每增加1=0.025MM
- 6 視窗: 顯示現在狀態。
- 7 針數: 設定工程所需要的針數0~999(手動時則不顯示)
- 8 手動: 用手動開關進入下一工程。
- 9 自動: 設定針數累計到達時依序進入下一車縫工程。
- 10 載入針數: 在試縫完成後可將計數器內所顯示的數字(針數)轉入"針數"的視窗內作為該工程的針數設定(注意!原針數會被覆蓋掉)
- 11 模式: 可儲存27組不同工程內容的資料(■, A~Z共27組)
(進入功能鍵模式內時另有用途請參照功鍵內容說明 第4~6頁)
- 12 電源: 燈亮時控制鍵才可操作(開關在電源箱)。
- 13 馬達送料: 按此鍵時馬達運轉, 可便於插入鬆緊帶用。
- 14 馬達停止: 按此鍵馬達停止運轉。(再按功能鍵時, 能測出縫紉機的轉速)
- 15 功能: 按此鍵時可提供各種縫製需要的功能設定(請參考功能說明, 第4~6頁)。

THE MANUAL OF THE CONTROL PANEL

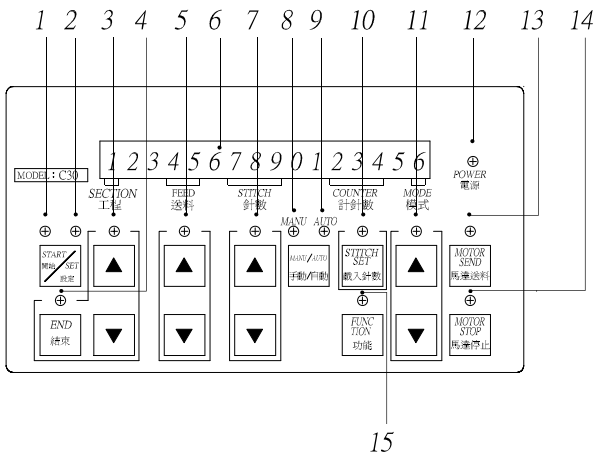

The instruction of the control box

- 1 Start (Circulating Switch) : Return to the status of the beginning.
- 2 Set (Circulating Switch) : Enter to the modified status.
- 3 Section : Setting the section from 1~9.
- 4 End : Press this key to complete the setting transaction.
- 5 Feed : To set the distance of each stitch when feeding From 00~99.
(00=0mm.For each additional one=0.025MM.)
- 6 Data Panel : Indicate the data status.
- 7 Stitch : To set the stitches from 000~999 for the need section.
- 8 Manual : During the manual condition, using the manual button to enter the next section.
- 9 Auto : When the stitch are executed, the machine will automatic progress in to the next section.
- 10 Stitch : After Complete the sewing test, press this key to duplicate the testing result of stitches to enter the setting of the next stitches section.
- 11 Mode : Use this key can memory up to 27 different sections of the information from ■ ,A~Z.
(For the detail,please refer to the functional guide in page 4-6.)
- 12 Power : Unable to operate unless this indicate lights is on. (Switch is on the power box.)
- 13 Motor send : Press this key to start the motor for easily insert the elastic tape.
- 14 Motor stop : Press this key to stop the motor.(To check the RPM figure,press the function key after press the motor stop.)
- 15 Function : Press this key to set the functional for all sewing type.(Please refer to the functional guide in page 4-6.)

功能鍵內容說明:按功能鍵二秒,修改出貨時已設定內容

FUNCTION KEY DATA INDEX:Press this key 2 sec
to changing pre-programed.

A. 補償針車高低速縫製時所產生的針目誤值

(車速愈快針目會愈大)

A. Compensation for the error stitch of the high/low sewing speed

(Higher speed then Bigger stitch)

B.送料範圍選擇

B.Choose the Feed Range

A 操作說明

A OPERATING INSTRUCTIONS

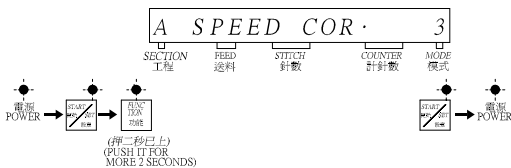

*:出貨時設定

*:Pre-programed

送料補償表

Compensation list

馬達轉數 R.P.M. Mode 模式編號	馬達轉數 R.P.M.			
	3000	4000	5000	6000
0	00	00	00	00
1	00	00	01	01
2	00	00	01	01
3	00	01	01	01
4	00	01	01	02
* 5	00	01	02	02
6	01	02	03	04
7	01	03	05	07
8	01	04	07	10
9	01	04	08	11

B OPERATING INSTRUCTIONS

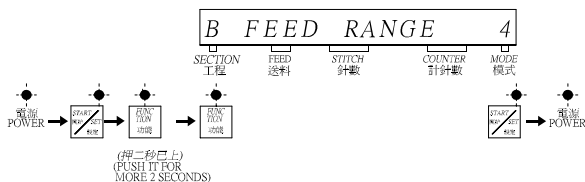

送料範圍表

*:出貨時設定

Feed Range List

*:PRE-PROGRAMMED

模式編號 Mode	送料範圍 Feed Range	適用針車 Applicable machines
0	0.2mm-1.2mm	四點人字車 Zig-Zag4point stitch
1	0.4mm-1.4mm	
*2	0.4mm-2.4mm	二點人字車 Zig-Zag2point stitch
3	0.6mm-2.6mm	
4	0.6mm-3.1mm	
*5	0.8mm-3.3mm	一般平車 Flat bed
6	1.0mm-3.5mm	
*7	1.1mm-3.6mm	縫邊車 Overlock
8	1.2mm-3.7mm	
9	1.3mm-3.8mm	

使用說明(本說明內容將由簡單漸進複雜方式)

OPERATION GUIDE (IT WILL BE FROM EASY TO COMPLEX.)

例一.

內容：單一工程為手動.

EXAMPLE 1.

CONTEXT : SINGLE SECTION FOR MANUAL.

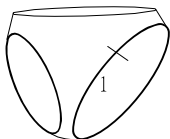

工程 SECTION	送料 FEED	針數 STITCH
1	50	

操作說明

OPERATION GUIDE

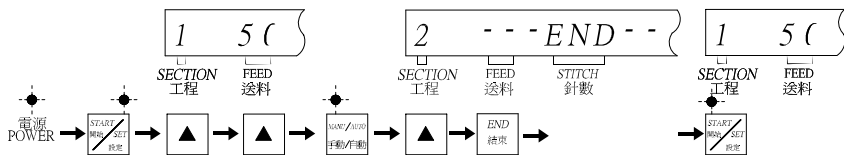

例二.

內容：一,二,三段工程均為手動.

EXAMPLE 2.

CONTEXT : ALL THREE SECTIONS ARE MANUAL.

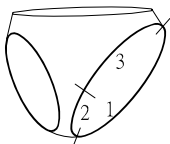

工程 SECTION	送料 FEED	針數 STITCH
1	70	
2	30	
3	70	

操作說明

OPERATION GUIDE

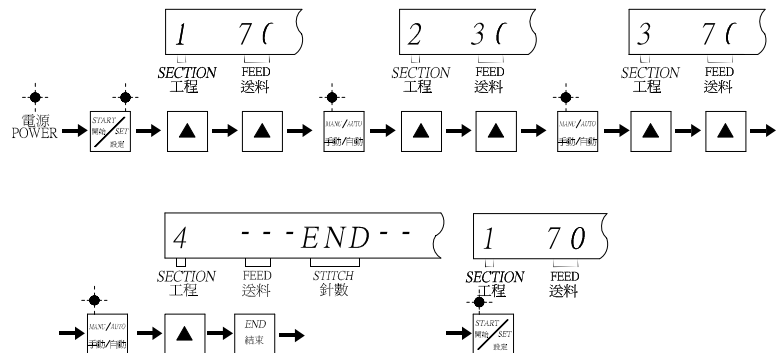

例三.

內容：單一段工程為自動.

EXAMPLE 3.

CONTEXT : SINGLE SECTION FOR AUTO.

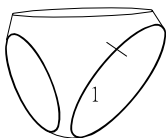

工程 SECTION	送料 FEED	針數 STITCH
1	50	165

操作說明

OPERATION GUIDE

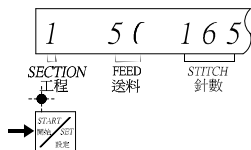
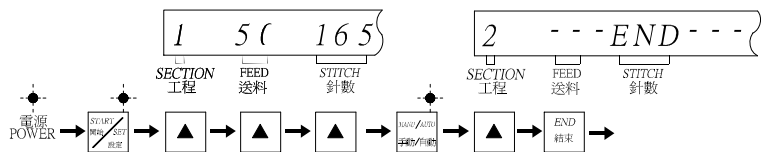

例四.

內容：一,二,三段工程均為自動.

EXAMPLE 4.

CONTEXT : ALL THREE SECTIONS ARE AUTO.

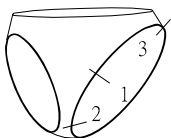

工程 SECTION	送料 FEED	針數 STITCH
1	70	100
2	30	50
3	70	10

操作說明

OPERATION GUIDE

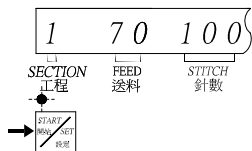
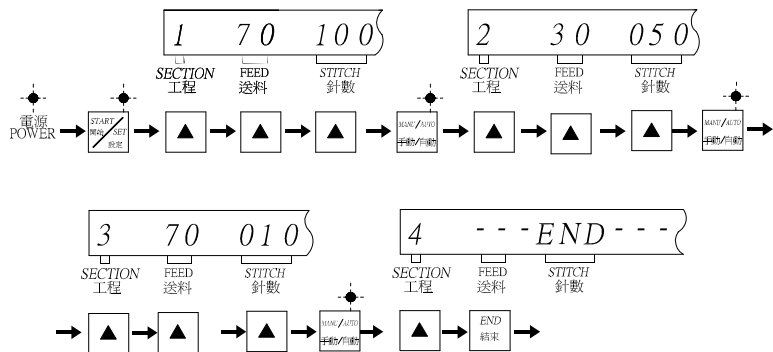

例五.

內容： 第一,二段工程為自動;第三段手動.

EXAMPLE 5.

CONTEXT : SECTION 1,2 ARE AUTO;SECTION 3 IS MANUAL.

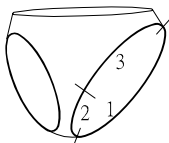

工程 SECTION	送料 FEED	針數 STITCH
1	70	100
2	30	50
3	70	-

操作說明

OPERATION GUIDE

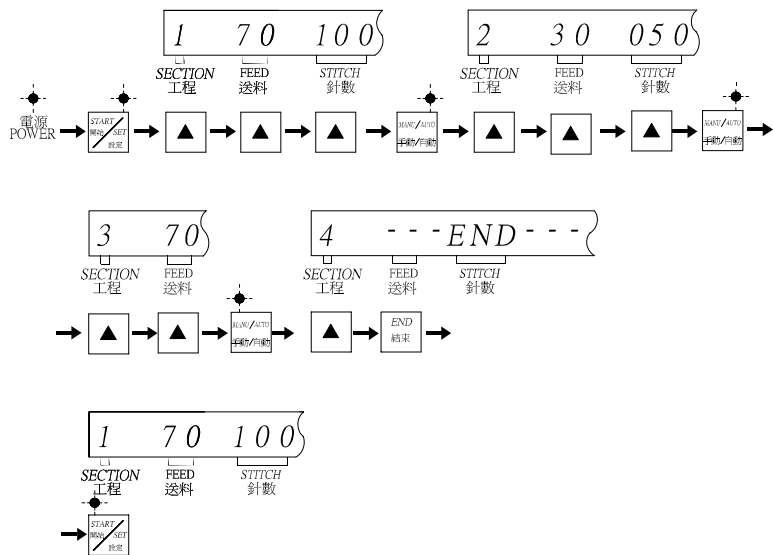

鬆緊帶換段修正功能：修正車縫時換段造成鬆緊帶誤差。

ADJUSTABLE FUNCTION AT INTERCOURSE SECTION
OF ELASTIC BAND : Correct stitching differential at
intercourse section of elastic band.

1. 功能說明：

為解決在多段車縫過程中，變換不同工程段落時，鬆緊帶將會產生緩衝段的誤差，可借由此功能來回拉或補償緩衝段的誤差。

1. Function Explanation :

To eliminate the difference at multi-section stitching while elastic band yields carved in and out, this function serves as a reparation and/or offsetting difference by pull and push back and forth.

2. 修正方式：

- A. 工程 1 換到工程 2 時由工程 1 修正。
- B. 工程 2 換到工程 3 時由工程 2 修正。
- C. 工程到最後一段返回工程 1 時由最後一段修正。

註：鬆緊帶修正值 0=0MM，每增加 1 為 0.35MM。(回拉或補償自動判斷)

2. Correction Module :

- A. Transit from 1st segment to 2nd segment: adjust from segment one.
- B. Transit from 2nd segment to 3rd segment: adjust from segment two.
- C. Rationalize above operation until it goes back to segment one: adjust from the last segment.

Note: Elastic Band correction value: 0=0mm, every extend one depicts 0.35MM. (Automatic judgment for pull or push compensation)

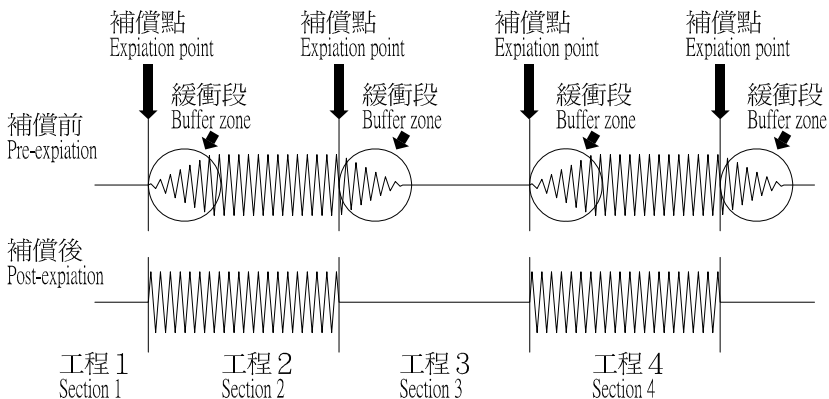

操作說明： OPERATION GUIDE：

例：工程段落修正值為 5 0。

Example: Section correction value reads 50.

