

MCA 20K⁻³⁸₋₆₄ /TR

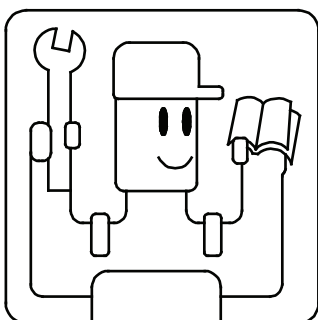

電子送帶機安裝手冊

THE INSTALLATION GUIDE BOOK

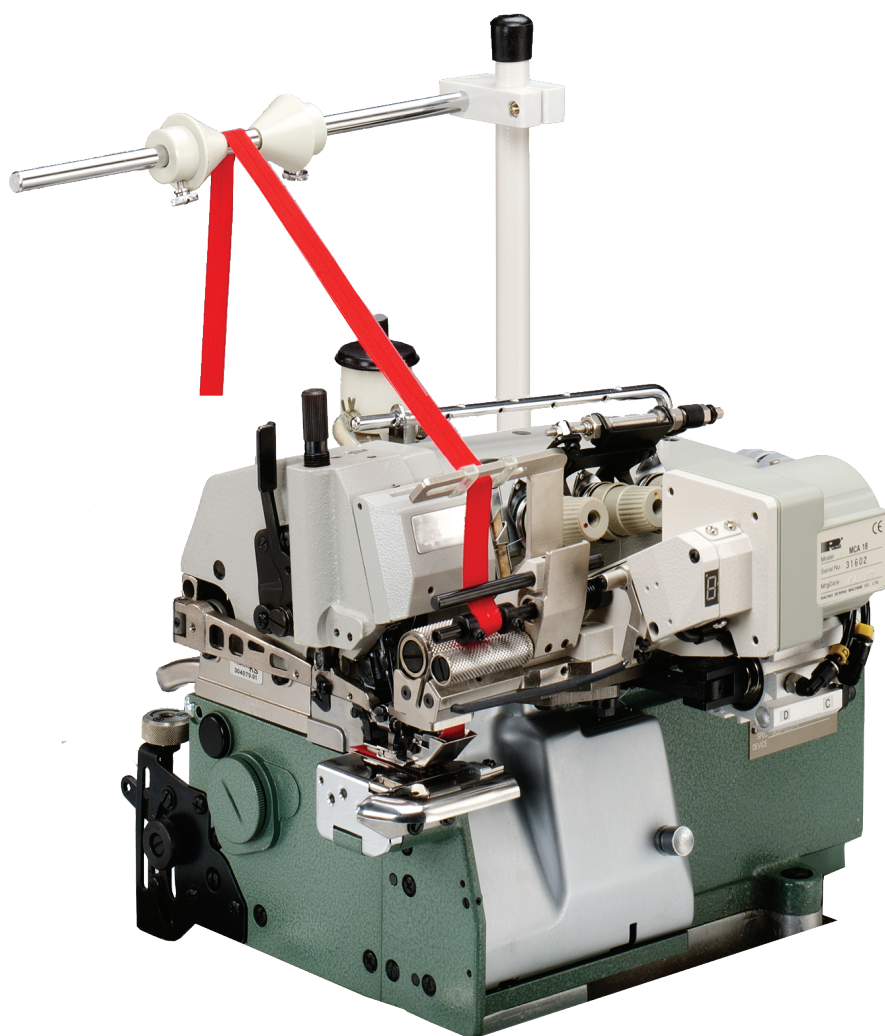

- 安裝前，請詳細閱讀安裝說明書
- PLEASE READ INSTRUCTIONS & ASSOCIATED DRAWINGS BEFORE INSTALLATION

注意：本送帶機必須使用下列規格的針板。

ATTENTION: THIS METERING DEVICE MUST BE OPERATE WITH THE FOLLOWING TYPE OF NEEDLE PLATE.

三線包縫車用

ONE NEEDLE OVERLOCK

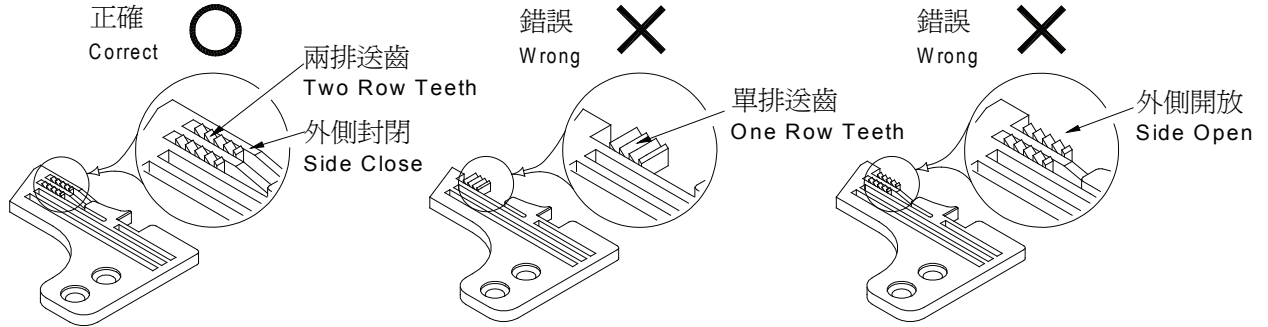

四線包縫車用

TWO NEEDLE OVERLOCK

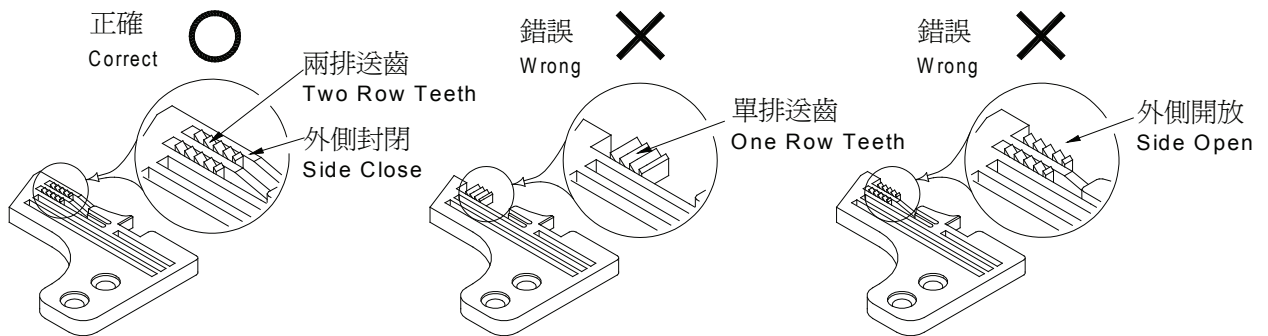

二: 放入鬆緊帶的正確位置:

2: THE RIGHT POSITION FOR INSERTING ELASTIC TAPE:

必需調整主機的紅點對準壓布腳入帶口的中央。

(送帶用吹氣孔是在紅點的下方)

Make sure the center of inserting slot of presser foot should meet the "RED" mark (The air jet hole is under the "RED" mark.)

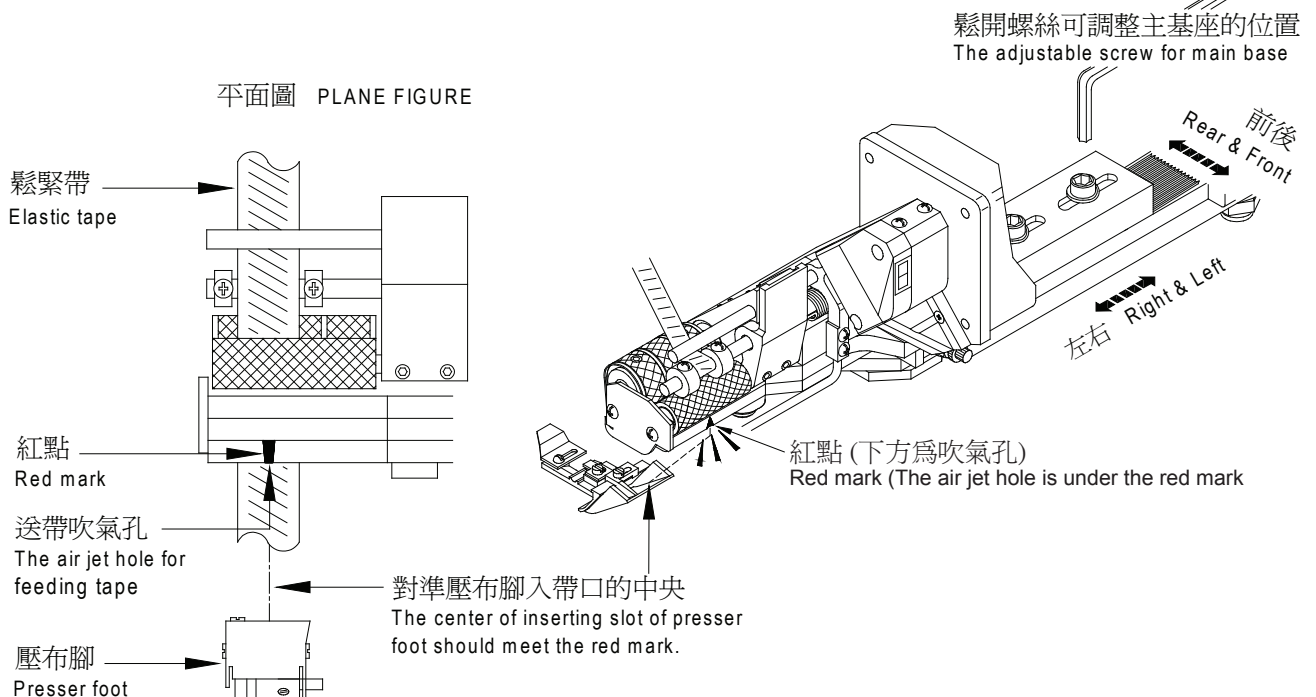

目錄
Index

	頁數 Page
組合圖 Assembly Combination	3
接線圖 Wiring Diagram	4
管路圖 Air Hose Diagram	5
零件圖 Parts List	6-9
操作手冊 Operation Guide	10-17
故障排除 Trouble Shotting	18

MCA20K 組合圖
MCA 20K Assembly Combination

主機組
MAIN MECHANISM

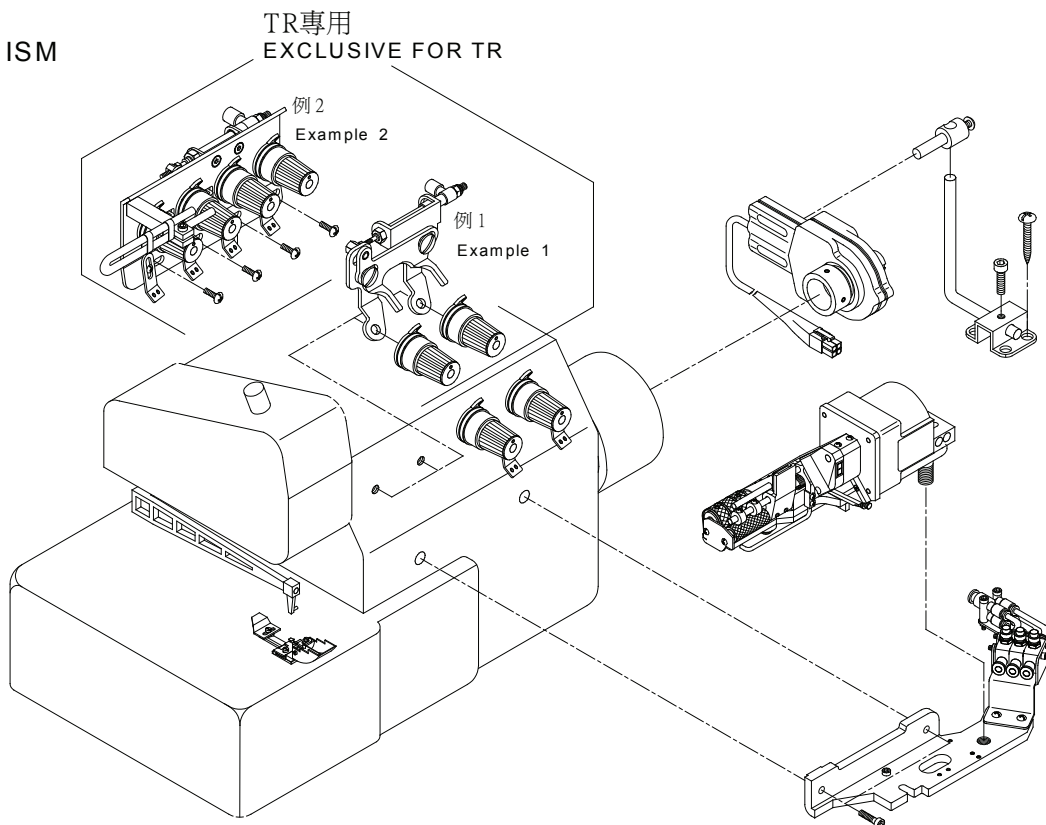

控制組
CONTROL BOX

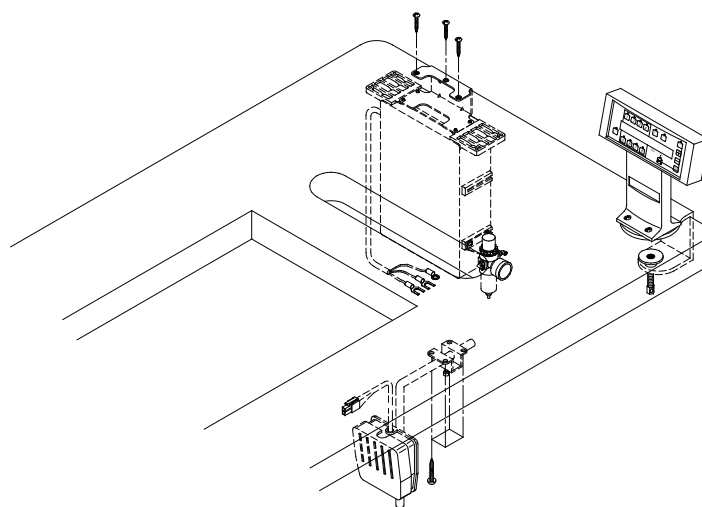

壓腳提升組
ACCESSORIES FOR PRESSER FOOT LIFTING

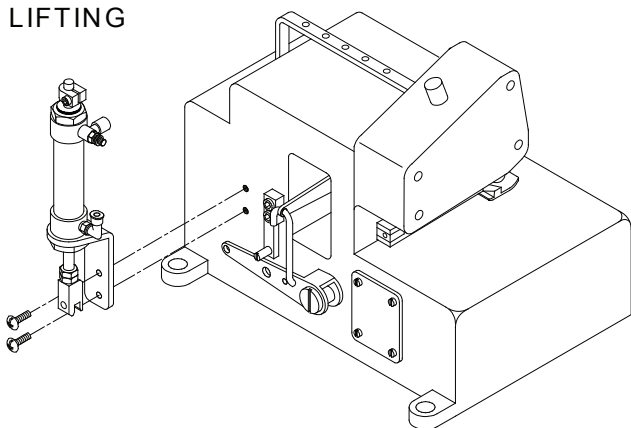

踏板開關
PEDAL SWITCH

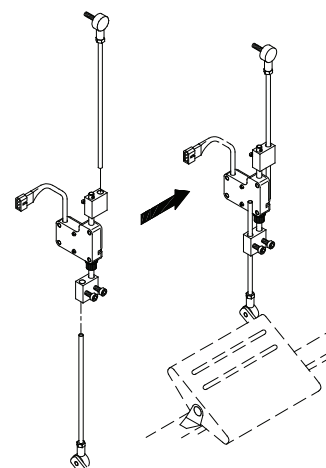

MCA20K 接線圖
MCA 20K Wiring Diagram

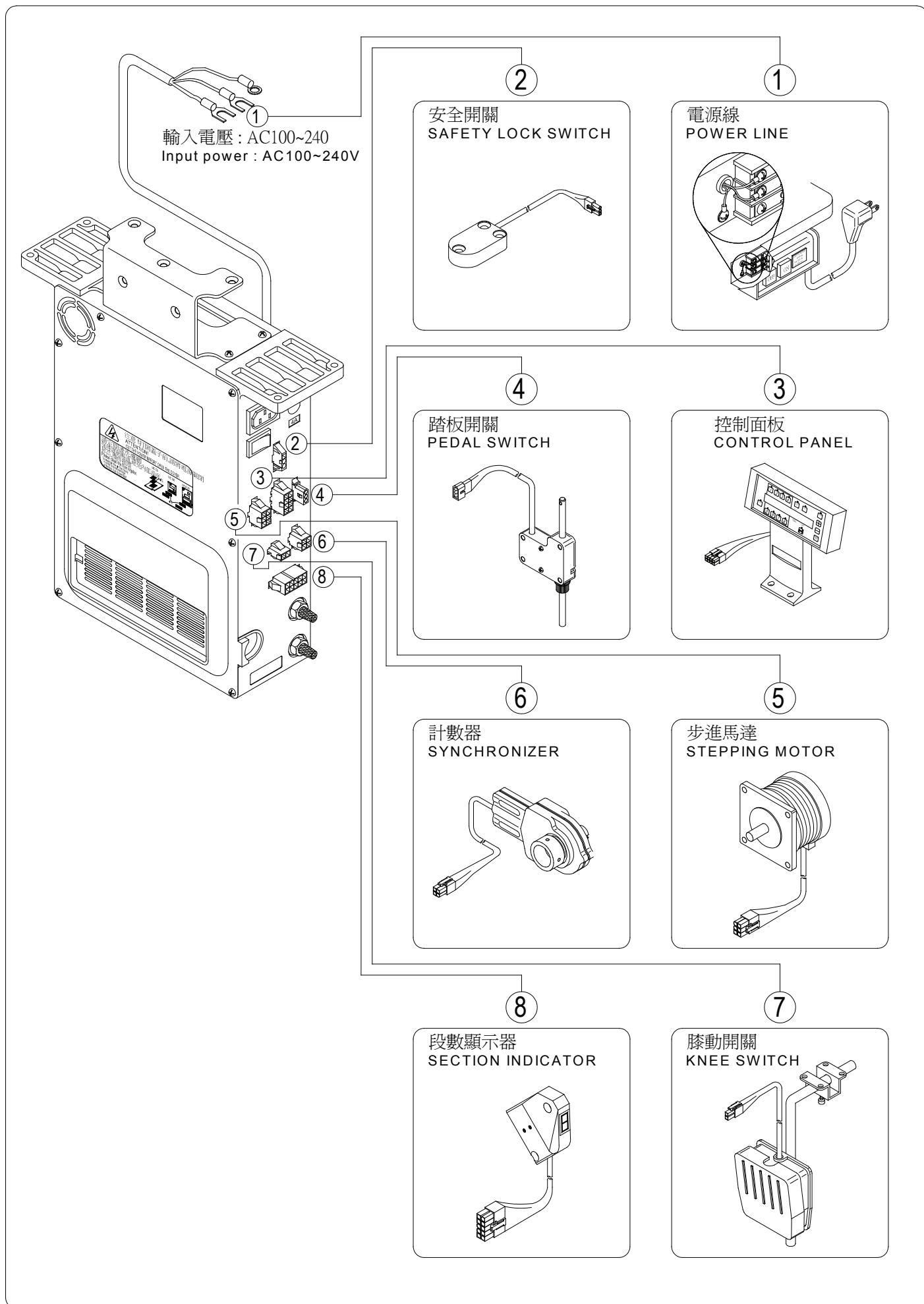

MCA20K 管路圖
MCA 20K Air Hose Diagram

空壓壓力：最小 4 kgf / cm²
Pressure Air : Min. 4 kgf / cm²

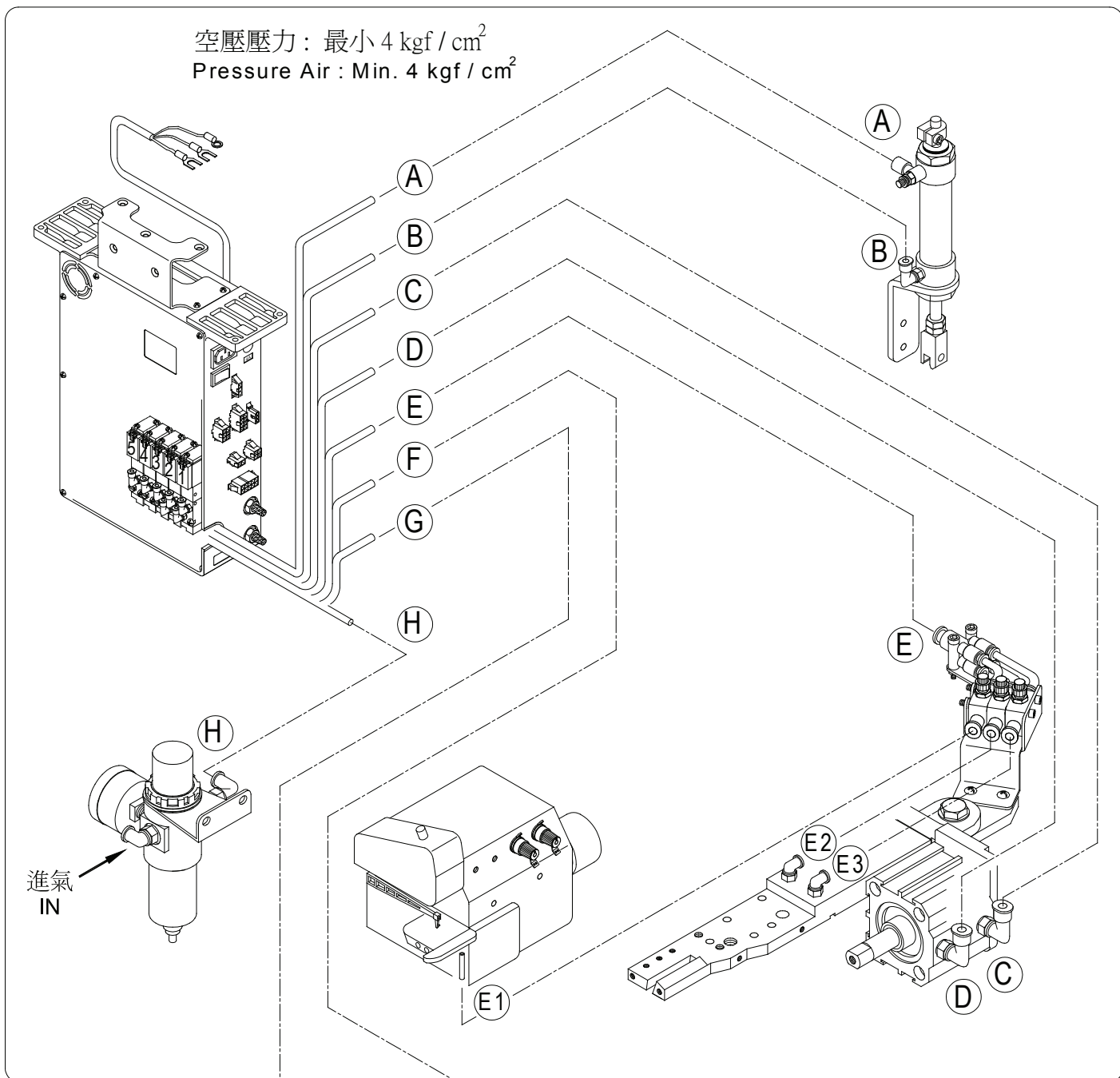

MCA20K ⁻³⁸/₋₆₄ 選擇性配件OPTIONAL PARTS

TR 鬆線裝置
TR Thread Release Device

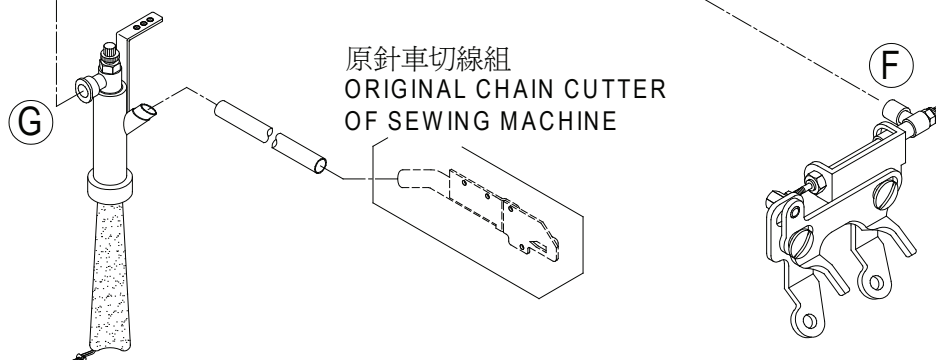

MCA20K 零件圖
MCA 20K Parts List

記號說明：
Mark description :

 選擇性配件
Optional parts

 選擇性配件,請告知針車廠牌機型
Optional parts, please indicate sewing machine model No.

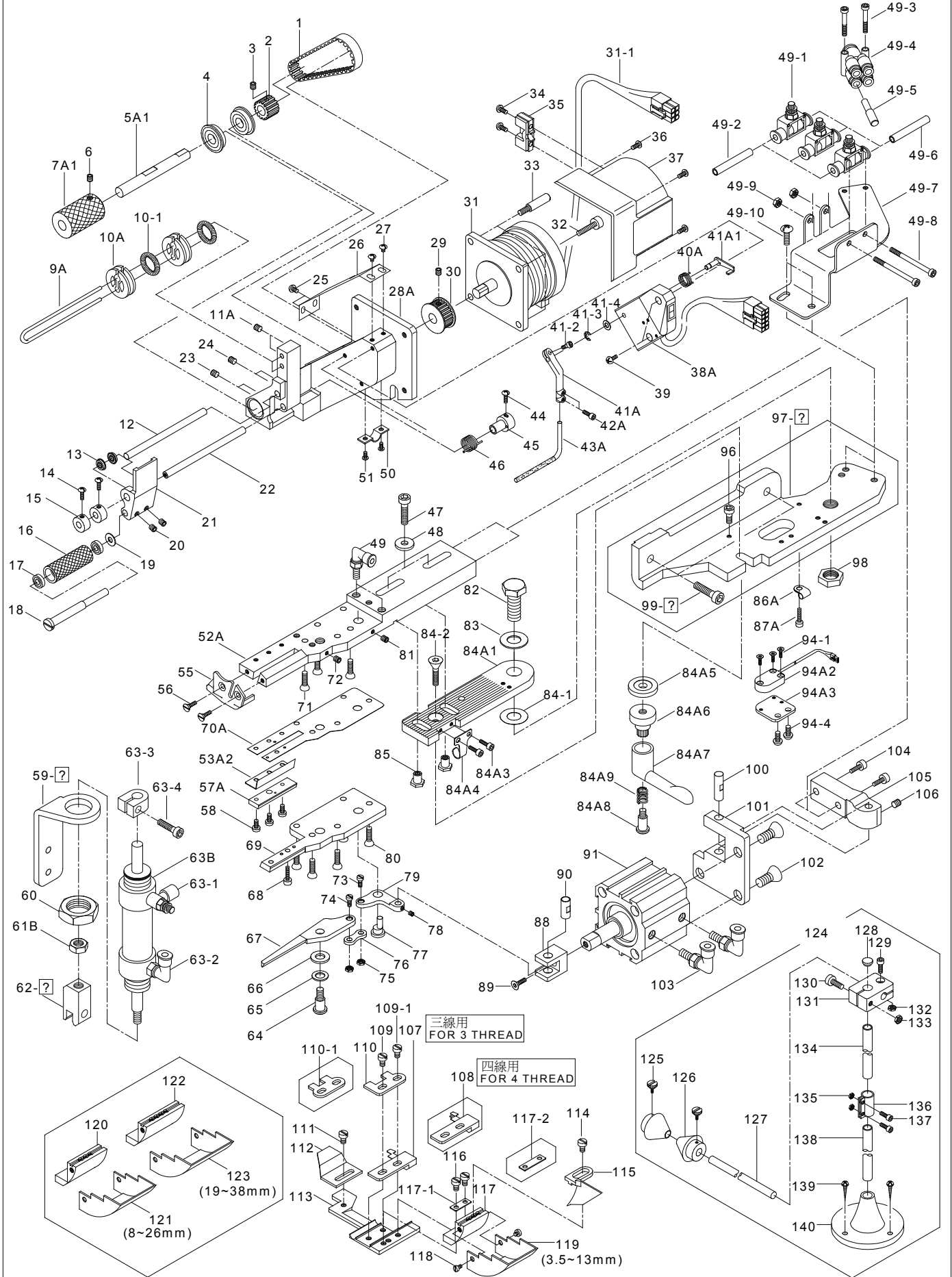

MCA20K-64 零件圖

Parts List for MCA 20K-64

記號說明：

Mark description :



選擇性配件
Optional parts



選擇性配件,請告知針車廠牌機型

Optional parts, please indicate sewing machine model no.

MCA 20K-64 專用配件

Exclusive parts for MCA 20K-64

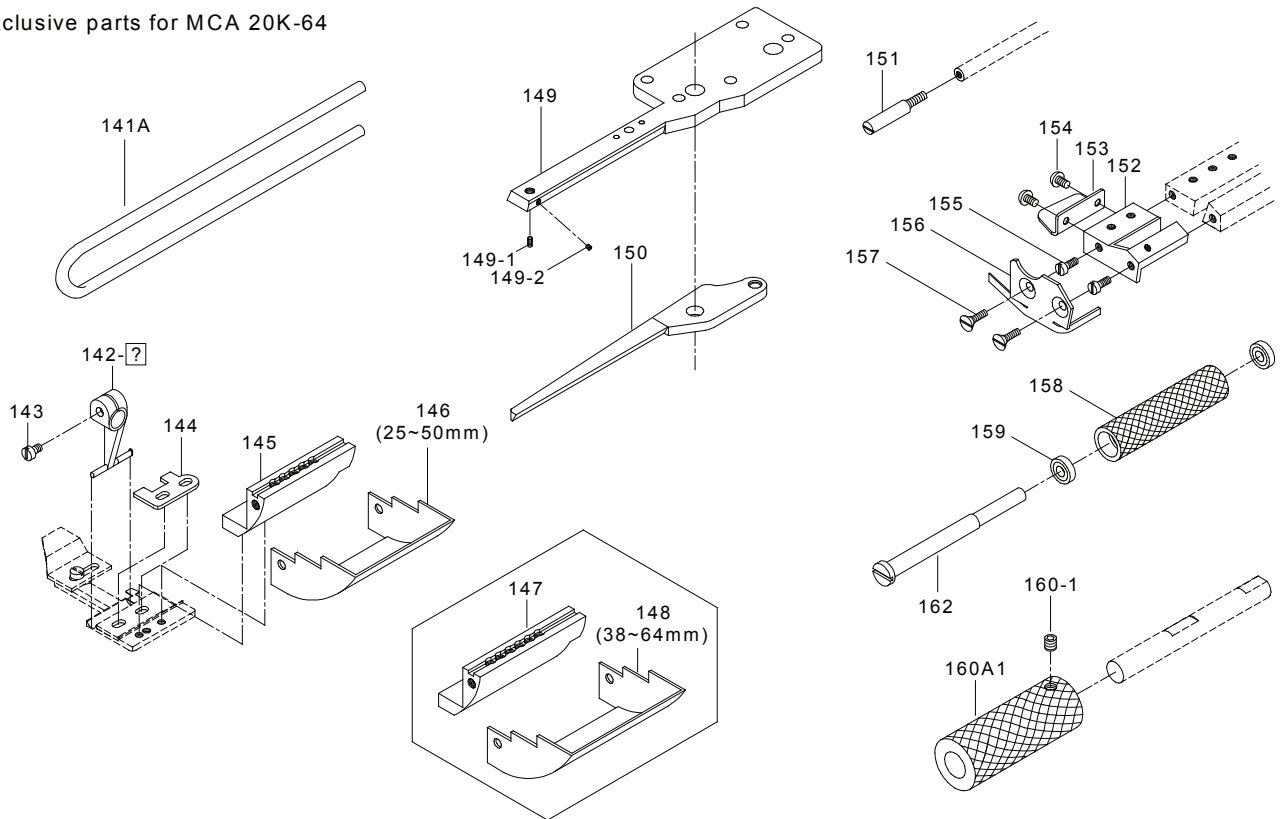

MCA 20K-38 專用壓腳

PRESSER FOOT FOR MCA 20K-38

163

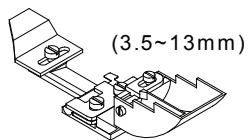

三線用
FOR 3 THREAD



四線用
FOR 4 THREAD

164

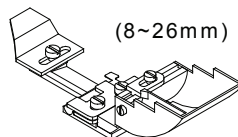

三線用
FOR 3 THREAD



四線用
FOR 4 THREAD

165

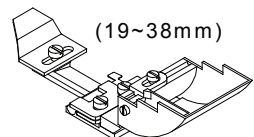

三線用
FOR 3 THREAD



四線用
FOR 4 THREAD

MCA 20K-64 專用壓腳

PRESSER FOOT FOR MCA 20K-64

166

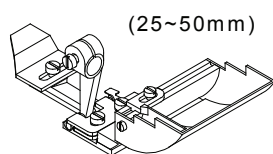

三線用
FOR 3 THREAD



四線用
FOR 4 THREAD

167

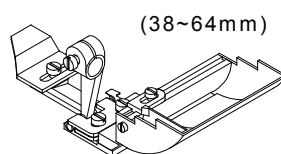

三線用
FOR 3 THREAD



四線用
FOR 4 THREAD

MCA20K / TR零件圖

Parts List for MCA 20K / TR

記號說明：
Mark description :

 選擇性配件
Optional parts

 選擇性配件,請告知針車廠牌機型
Optional parts, please indicate sewing machine model no.

TR 專用配件
Exclusive parts for TR

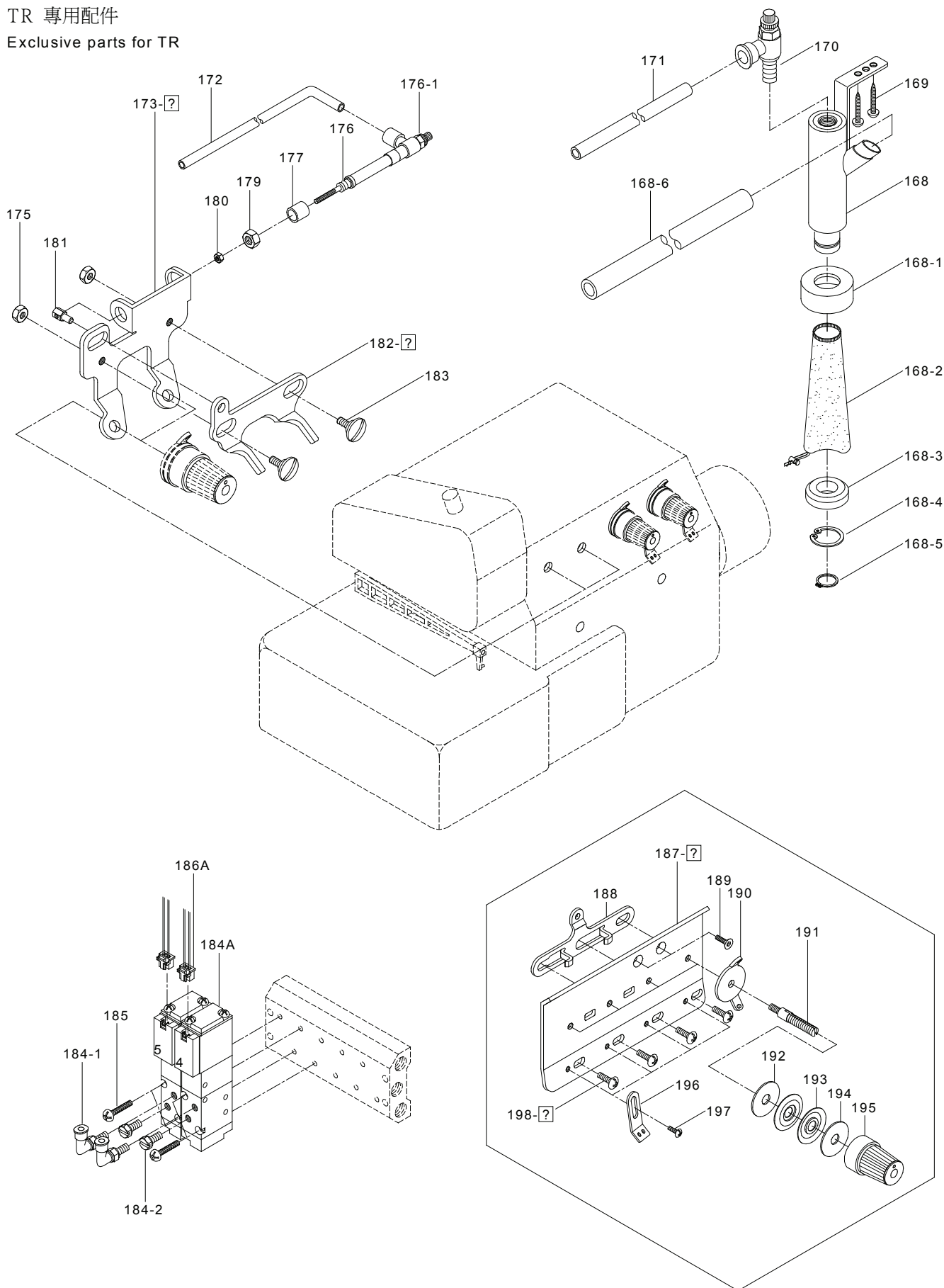

MCA20K⁻³⁸/₋₆₄ /TR零件圖
Parts List for MCA 20K⁻³⁸/₋₆₄ /TR

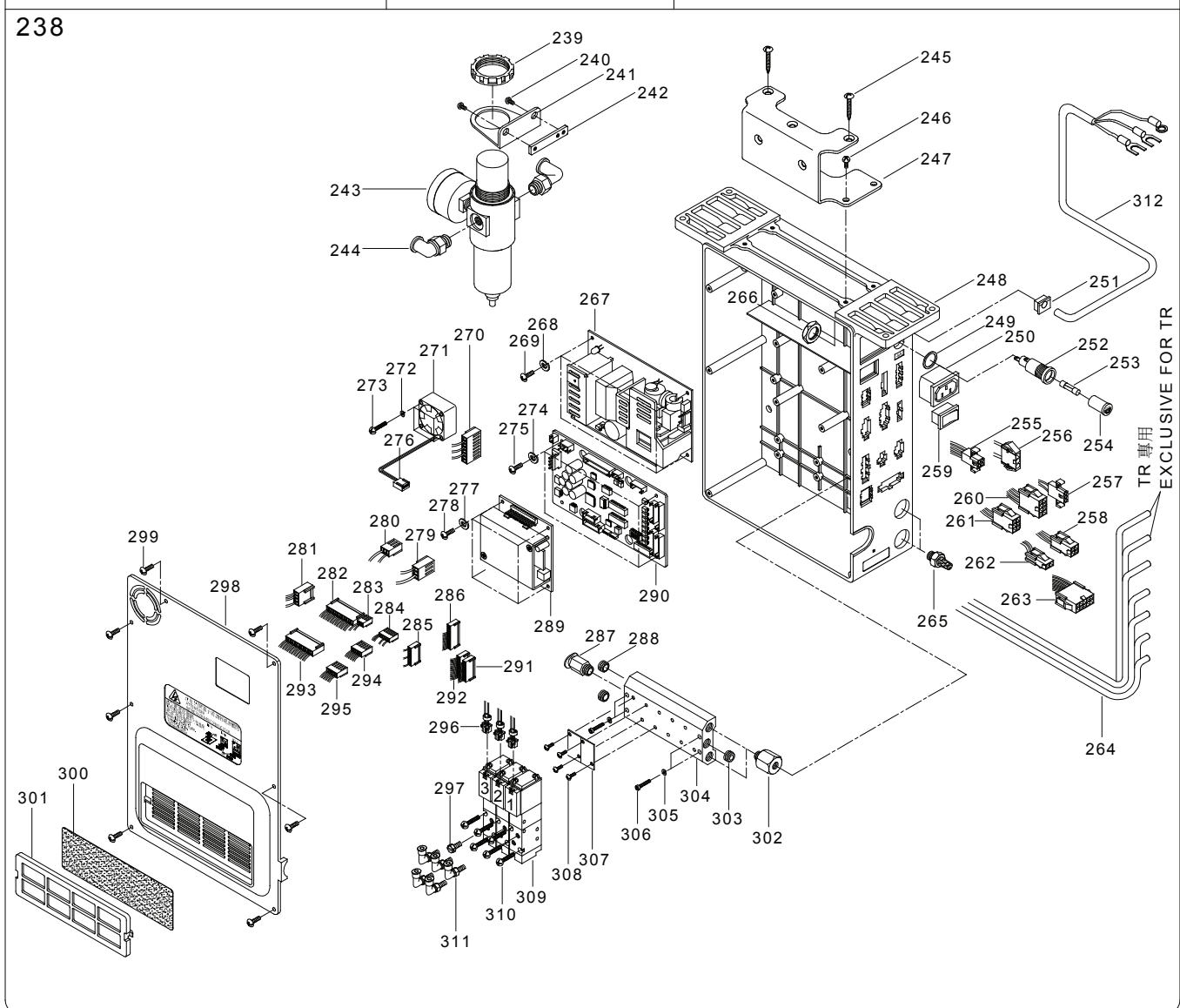
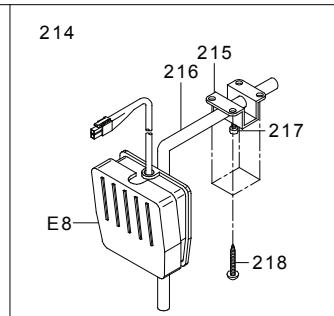
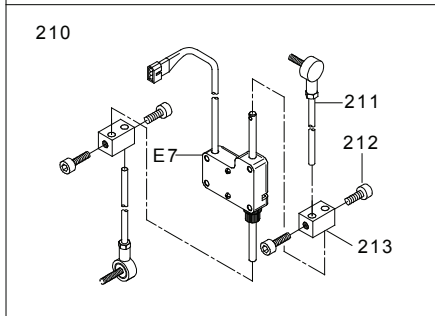
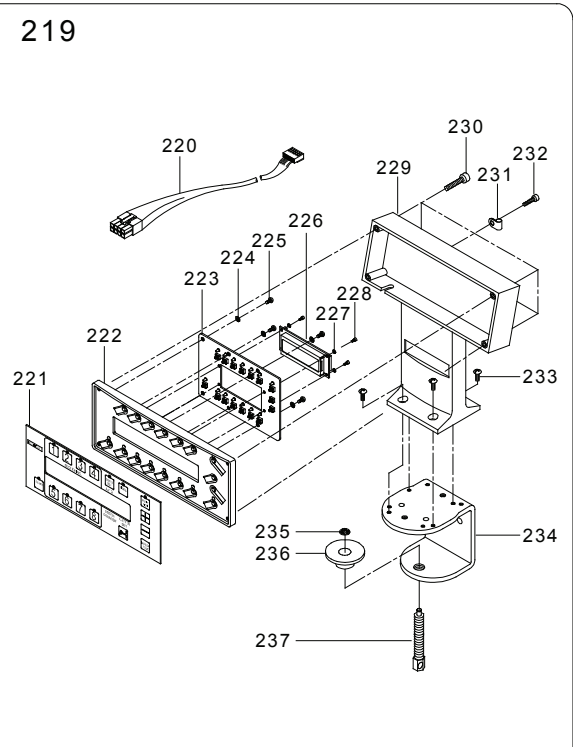
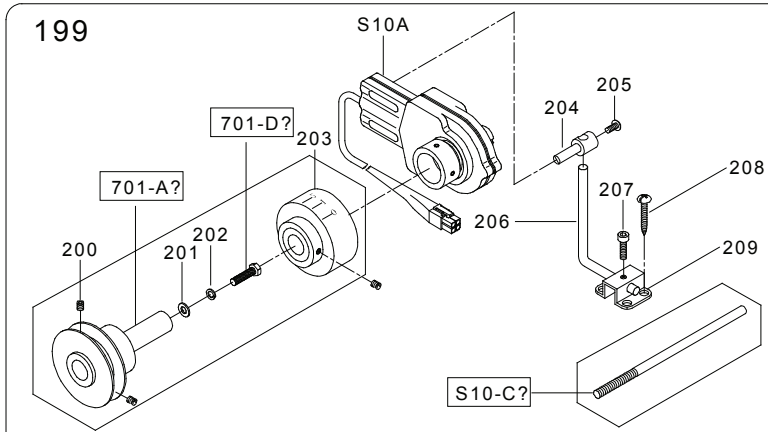

操控說明

OPERATION GUIDE

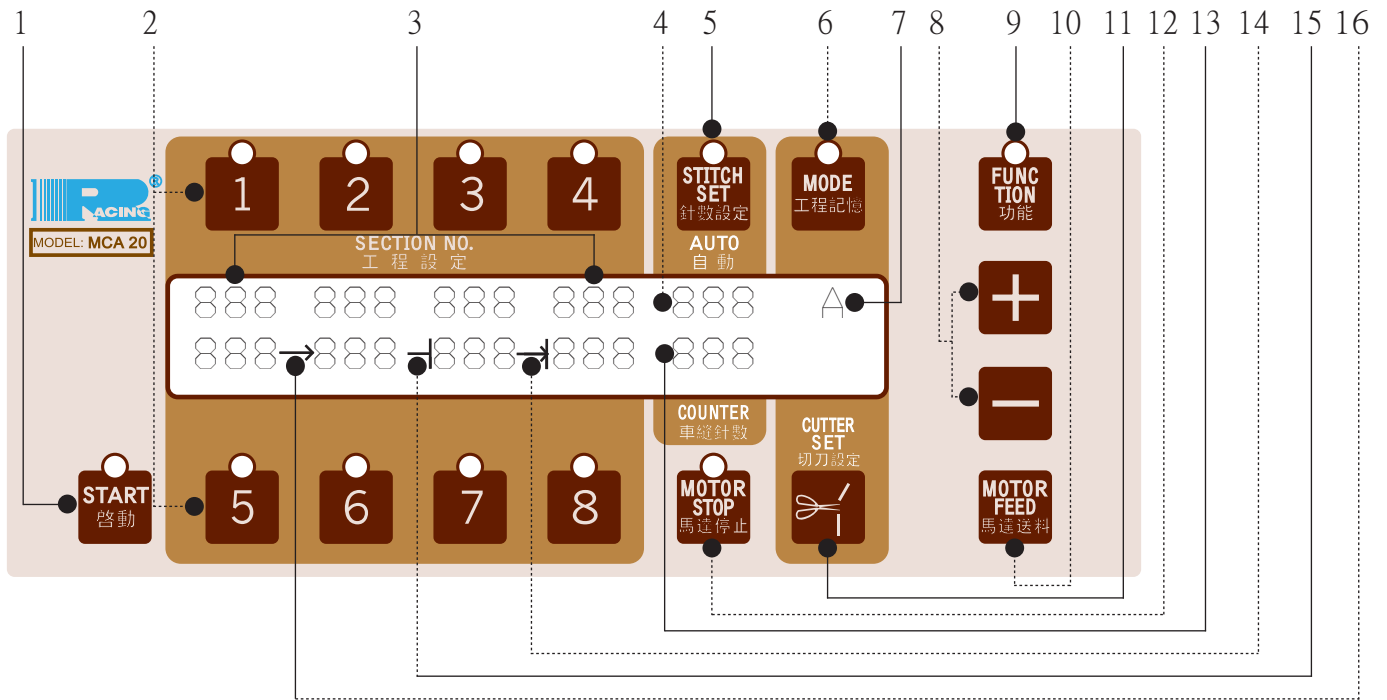

視窗及按鍵說明：

- | | |
|---------------|------------------------------------|
| 1. 啟動鍵： | 進入車縫模式用。 |
| 2. 工程設定選擇鍵： | 共有八段工程可供設定鬆緊度。 |
| 3. 送料值顯示窗： | 顯示各段工程鬆緊度之設定值，一共有八段，每段設定值均可從1~999。 |
| 4. 針數設定顯示窗： | 顯示針數設定數值，空白或1~999。 |
| 5. 針數設定鍵： | 於自動換段車縫時設定使用。(參照第15~17頁) |
| 6. 工程記憶鍵： | 可儲存26組(A~Z)不同工程內容的資料。(參照第17頁) |
| 7. 工程記憶顯示窗： | 顯示工程記憶之設定值(A~Z)。 |
| 8. +, - 鍵： | 使用+, - 鍵來更改各項功能的設定數值。 |
| 9. 功能設定鍵： | 特殊功能設定。(參照第11頁) |
| 10. 馬達送料鍵： | 按此鍵時馬達運轉,送入鬆緊帶。 |
| 11. 切刀設定鍵： | 設定段落切帶。(請參照第16~17頁) |
| 12. 馬達停止鍵： | 設定馬達與裝置停止動作。 |
| 13. 針數顯示窗： | 顯示車縫時的針數，最多針數999針。 |
| 14. 段落自動切帶符號： | → 顯示段落自動切帶。 |
| 15. 段落切帶符號： | — 顯示段落手動切帶。 |
| 16. 自動換段符號： | → 顯示自動換段。 |

Control Panel Instructions: Refer to Figure 1.

- | | |
|-------------------------------|--|
| 1. START : | Press Start to normal sewing operation. |
| 2. SECTION TENSION : | To set each Sections' tension, Up to 8 different Sections per program. |
| 3. SECTION PANEL : | Displays all the Sections' status from 1~999. |
| 4. STITCH DISPLAY : | Indicate the number of stitches to be sewn from 1~999 for Auto section change. |
| 5. STITCH SET : | Stitch count setting. (page15~17) |
| 6. MODE : | Use this key to memorise up to 26 different programs from A~Z. (Page17) |
| 7. MODE DISPLAY : | Indicates the Mode which you have set (A~Z). |
| 8. +, - KEY : | Use the +, - key to Adhust all settings. |
| 9. FUNCTION SETTING KEY: | Press this key to activate for setting the SPECIAL functions. (Page 11) |
| 10. MOTOR FEED : | Press this key to set the elastic tape. |
| 11. CUTTER SET : | To cut the elastic tape between sections.(Page15) |
| 12. MOTOR STOP : | To Stop device running. |
| 13. COUNTER DISPLAY: | Indicate the number of stitches sewn up to 999. |
| 14. AUTO CUT SIGN: | → Indicate To cut the elastic tape between sections by Stitch Cunter. |
| 15. CUT SIGN: | — Indicate To cut the elastic tape between sections. |
| 16. Auto Section Change Sign: | → Indicate Auto change to the next section. |

操控說明 OPERATION GUIDE

功能:
FUNCTION:

01. 進帶長度 (00= 35mm 每增加1=1mm, 99=134mm)
Length of Inserting Tape (000=0mm, Every 1 unit=1mm, 99=134mm)
02. 進帶速度 (00=50mm/秒 每增加1=1.9mm/秒. 99=238.1mm/秒)
Speed of Inserting Tape
(00=50mm/Sec., Every 1 unit=1.9mm/Sec., 99=238.1mm/Sec.)
03. 始縫時鬆緊帶回拉 (00=0mm 每增加1=0.35mm, 99=34mm)
Pull back tape at beginning sewing
(00=0mm, Every 1 unit=0.35mm, 99 = 34mm)
04. 切刀吻合時間 (000= 0.01秒 每增加1=0.01秒, 99=1秒)
Cutter Timer (00=0.01Sec. Every 1 unit=0.01Sec. 99=1Sec.)
05. 切刀後,車縫針數. TR與真空吸風裝置會啓動 (TR專用)
(00=0針 每增加1=1針, 99=99針)
Stitch after Cut to Active TR and Vacuum device (For TR deviceOnly)
(00=0 stitch, Every 1 unit=1 stitch, 99=99 stitch)
06. ON:車縫完成停止後押腳自動提昇進帶
ON: Pressure Foot lifted up and Insert the Tape after completely operation.
07. 始縫時,真空吸風裝置動作針數 (TR專用)
(00= 0針 每增加1=1針, 99=99針, ON=連續吸風)
Vacuum Actives stitch at beginning sewing (For TR device Only)
(00=0 stitch, Every 1 unit=1 stitch, 99=99 stitch, ON=Non-stop)
08. 開始送帶針數 (00=0 針 每增加1=1針, 99=99針)
Stitch for Start Feed Tape (00=0 stitch, Every 1 unit=1 stitch, 99=99 stitch)
09. 切刀後送帶長度
(00= 0mm 每增加1=0.35mm, 99=34mm)
Feed Tape after Cut
(00=0mm, Every 1 unit=0.35mm, 99=34mm)
10. 切刀後張力控制器 (RTA專用)
(OFF=關, 01=1針 每增加1=1針, 99=99針)
Ending Tape tesnion after Cut (For RTA device Only)
(OFF= No function, 01=1stitch, Every 1 unit=1stitch, 99=99stitch)
11. 切刀延遲時間 (RTA專用)
(00=0秒 每增加1=0.005秒, 99=0.5秒)
Cutter Delay Timer Cut (For RTA device Only)
(00=0 Sec. Every 1 unit=0.005 Sec. 99=0.5 Sec.)

1	2	3	4	STITCH SET 針數設定	MODE 工程記憶
01	INSER	TAPE	LENGTH		20
5	6	7	8	STITCH COUNTER 車縫針數	
1	2	3	4	STITCH SET 針數設定	MODE 工程記憶
02	INSER	TAPE	SPEED		50
5	6	7	8	STITCH COUNTER 車縫針數	
1	2	3	4	STITCH SET 針數設定	MODE 工程記憶
03	INSER	TAPE	TENSION		00
5	6	7	8	STITCH COUNTER 車縫針數	
1	2	3	4	STITCH SET 針數設定	MODE 工程記憶
04	CUTTER	TIMER			30
5	6	7	8	STITCH COUNTER 車縫針數	
1	2	3	4	STITCH SET 針數設定	MODE 工程記憶
05	END	V-ON	STITCH		15
5	6	7	8	STITCH COUNTER 車縫針數	
1	2	3	4	STITCH SET 針數設定	MODE 工程記憶
06	AUTO	FOOT	UP		OFF
5	6	7	8	STITCH COUNTER 車縫針數	
1	2	3	4	STITCH SET 針數設定	MODE 工程記憶
07	START	V-OFF	STITCH		10
5	6	7	8	STITCH COUNTER 車縫針數	
1	2	3	4	STITCH SET 針數設定	MODE 工程記憶
08	START	TENSION	STITCH		03
5	6	7	8	STITCH COUNTER 車縫針數	
1	2	3	4	STITCH SET 針數設定	MODE 工程記憶
09	FEED	TAPE	AFTER CUT		00
5	6	7	8	STITCH COUNTER 車縫針數	
1	2	3	4	STITCH SET 針數設定	MODE 工程記憶
10	TAPE	ENDING	TENSION		OFF
5	6	7	8	STITCH COUNTER 車縫針數	
1	2	3	4	STITCH SET 針數設定	MODE 工程記憶
11	CUTTER	DELAY	TIMER FOR RTA		10
5	6	7	8	STITCH COUNTER 車縫針數	

操控說明 OPERATION GUIDE

專業功能: ADVANCE FUNCTION:

A. 速度補償: 依車縫速度越, 補償送料值.
A. Speed Compensation: Compensation Feed by different sewing speed.



操作說明:
Operation Guide:

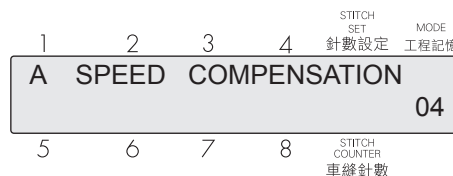
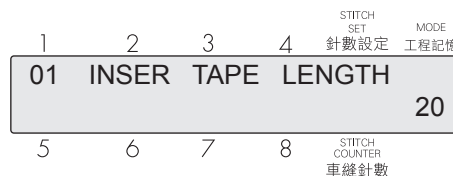
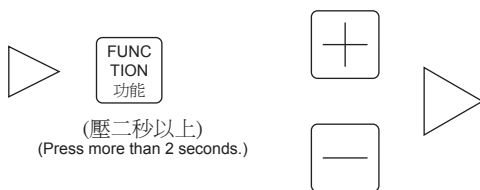

補償表
Setting List

* 出廠設定
Default



設定值 SETTING 車速 R.P.M.	0	1	2	3	*4	5	6	7	8	9
3000	000	000	000	000	000	000	010	010	010	010
4000	000	000	000	010	010	010	020	030	040	040
5000	000	010	010	010	010	020	030	050	070	080
6000	000	010	010	010	020	020	040	070	100	110

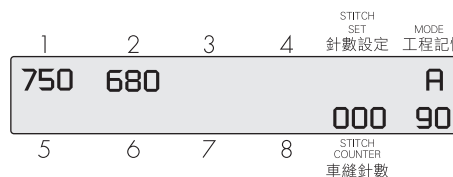
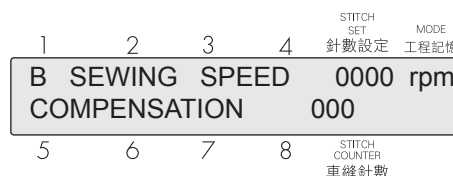

車縫狀態檢視: 可檢視車縫速度與補償值.
Sewing Statue Check: It can show the sewing machine Speed and Compensation Value.



操控說明 OPERATION GUIDE

符號說明：
Description for Special Figures Used In This Manual :

-  數值閃爍時,表示可修改。
Value can be adjusted when it is flashing.
-  表示自動換段。
Auto Sections Change by Stitch Counter-SY.

-  切刀後,前往下段工程。
Continue to next Section after Cut.
-  自動切刀後,前往下段工程。
Continue to next section after Auto Cut.

連續按兩下段數之數字鍵,可以刪除多餘的段數。
Push the section button twice to erase the extra sections.

 操作說明:
Operation Guide:



START
啟動

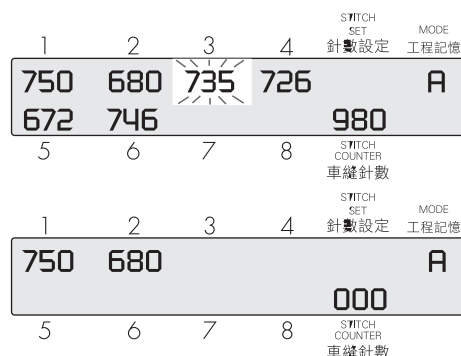

如需設定第一段之自動換段針數,按下”1”號鍵後按壓“針數設定”鍵,進入針數設定,以+ - 鍵來調整針數。
Press Section 1 key and then press Stitch Set button. You can adjust the stitch for Auto section change by press + - key.

 操作說明:
Operation Guide:

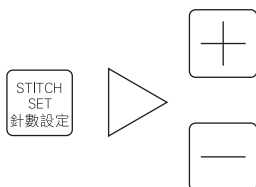

START
啟動



連續按兩下針數設定鍵,可以解除自動換段功能。
Press the Stitch Set button twice to disable Auto function.

 操作說明:
Operation Guide:



START
啟動



操控說明 OPERATION GUIDE

使用說明: Operation Guide:

例一: 單一工程 Example 1: Single Section



操作說明:
Operation Guide:

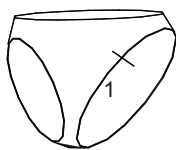
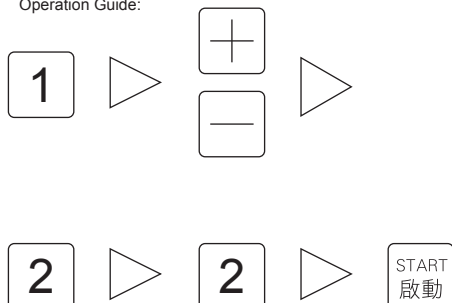

工程 SECTION	送料 FEED	針數 STITCH
1	500	

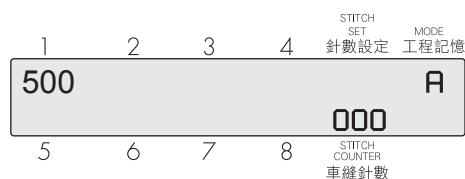
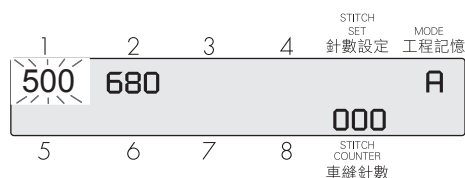

例二: 三段手動換段工程 Example 2: 3 Sections by Manual



操作說明:
Operation Guide:

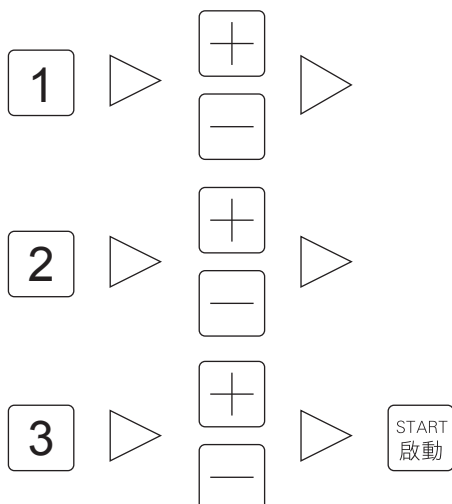

工程 SECTION	送料 FEED	針數 STITCH
1	700	
2	300	
3	700	

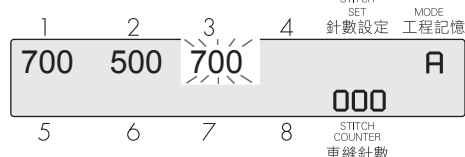
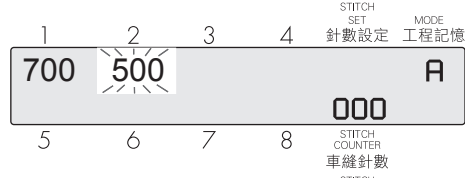
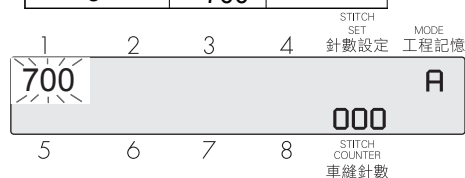

例三: 一段工程 自動切刀 Example 3: 1 Section with Auto Cut



操作說明:
Operation Guide:

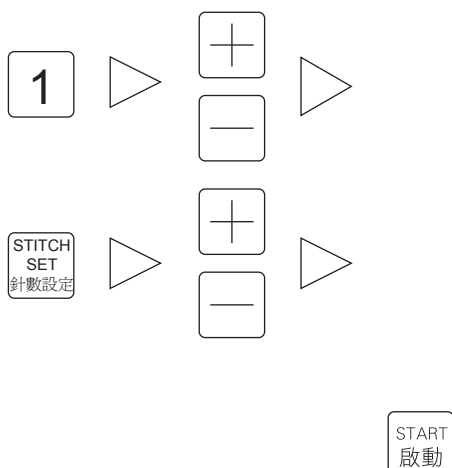

工程 SECTION	送料 FEED	針數 STITCH
1	500	165

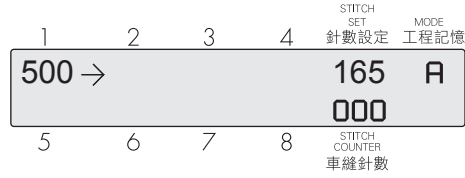
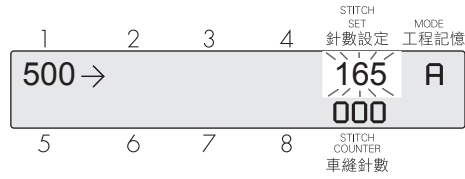
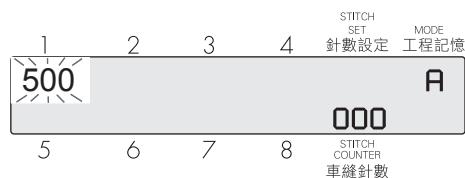

操控說明 OPERATION GUIDE

例 四: 三段工程. 一、二段自動換段,
三為手動切刀
Example 4: 3 sections, Section1 & 2 are Auto
Section 3 is Manual.

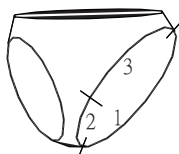

操作說明:
Operation Guide:

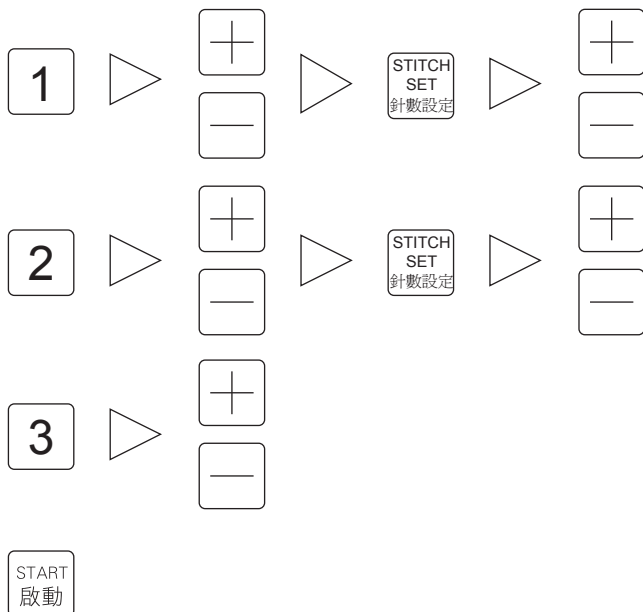

工程 SECTION	送料 FEED	針數 STITCH
1	700	150
2	300	75
3	700	



例 五: 三段工程. 一、二段自動換段,
三段為自動切刀
Example 4: 3 sections, Section1 & 2 are Auto
Section 3 is Auto cut.

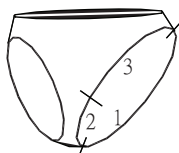

操作說明:
Operation Guide:

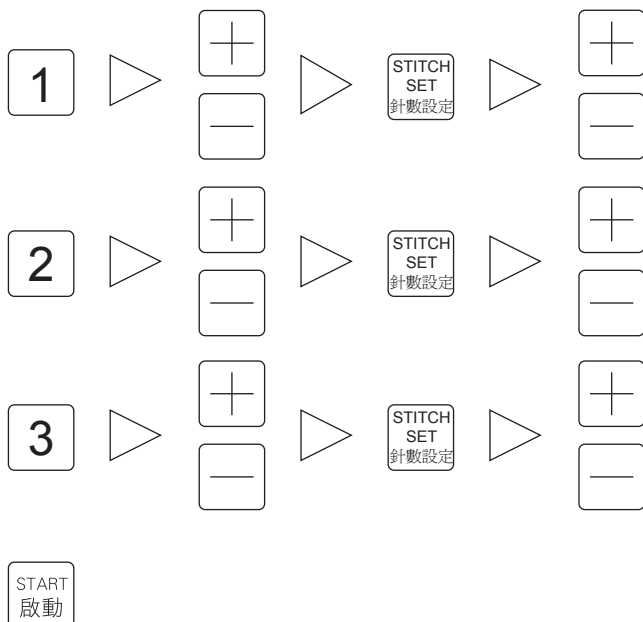

工程 SECTION	送料 FEED	針數 STITCH
1	615	125
2	255	65
3	535	115



操控說明 OPERATION GUIDE

例 六: 褲腳左右兩邊車縫
左右兩邊褲腳各只有一段工程
鬆緊帶以針數自動切刀
啓縫時鬆緊回拉約1公分



Example 6: Two leg openings of slips
Each slip is with 1 section.
Tape Cut by Auto Stitch Counter
With about 1cm tape Pull Back function at beginning.



操作說明:
Operation Guide:

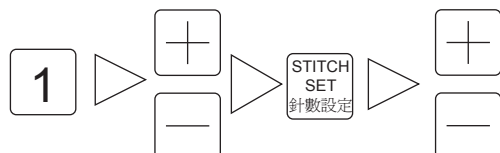

注意: 此符號意思為切刀後 會繼續下一段未完成的工程
Noticed: This sign is mean the section is not finish yet after section cut.

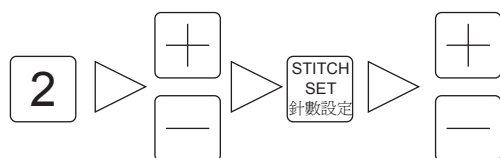

按功能鍵4次,進入
04 INSER TAPE TENSION
Push Function Key to enter
04 INSER TAPE TENSION



例 六: 褲腳左右兩邊車縫
左右兩邊褲腳各有三段工程
設定工程自動換段,手動切刀

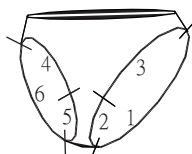

Example 6: Two leg opening of slips
Each slip is with 3 sections.
Section change by Auto, Cut by Manual



操作說明:
Operation Guide:

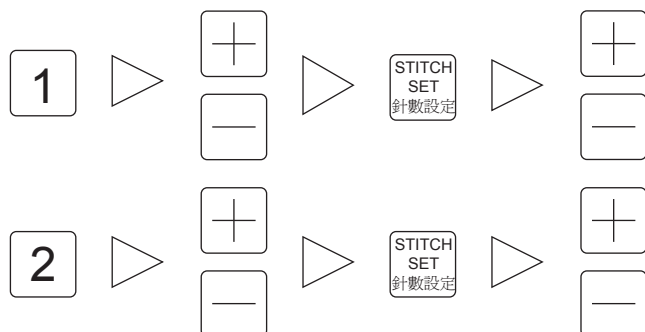

工程 SECTION	送料 FEED	針數 STITCH
1	355	215
2	366	223

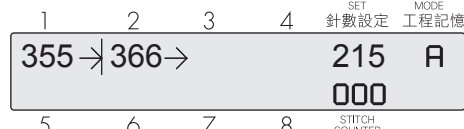
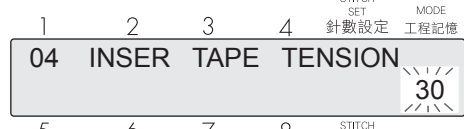
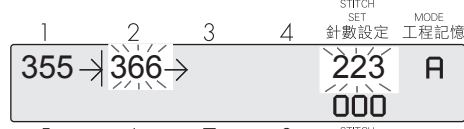
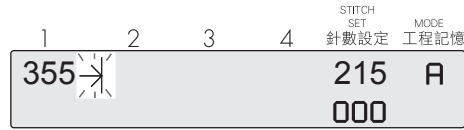
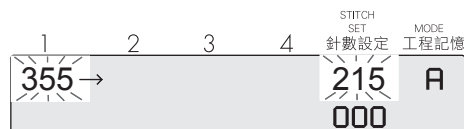

工程 SECTION	送料 FEED	針數 STITCH
1	355	110
2	211	75
3	321	
4	315	105
5	208	68
6	334	

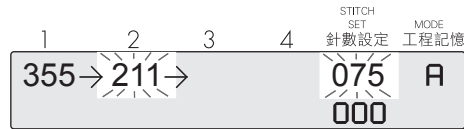
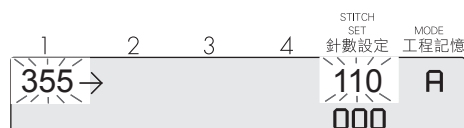

操控說明 OPERATION GUIDE

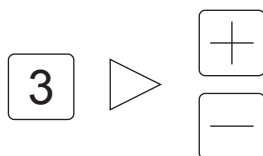

注意: 此符號意思為切刀後 會繼續下一段未完成的工程
Noticed: This sign is mean the section is not finish yet after section cut.

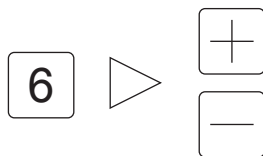
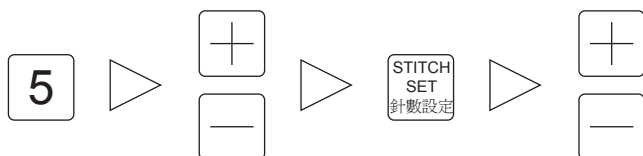
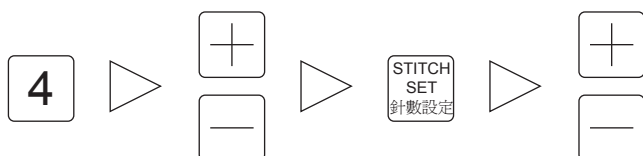

START
啟動

例 七: 更換模式,由模式A換到模式B.

Example 7: Switch MODE form Mode A to Mode B



操作說明:
Operation Guide:

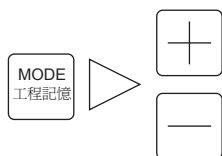

START
啟動



故障排除 SOLUTION FOR ERROR FUNCTION

現 像	原 因	解 決 方 法
送帶機異常振動	1.送帶機與縫紉機銜接的螺絲鬆弛	1.參照第 2 頁重新固定
送帶機無動作	1.電源未接妥善 2.線路系統斷路 3.控制系統故障	1.參照第 4 頁設定 2.參照第 4 頁檢查各線路插座與插頭接腳是否鬆脫 3.通知維修人員進行更換維修
螢幕不顯示	1.面板故障	1.通知維修人員進行更換維修
模式數值無法記憶	1.記憶體故障	1.通知維修人員進行更換維修
送帶不順	1.送帶位置或裝置不當 2.吹氣孔氣量不足或位置不當	1.參照第 01 頁重新固定 2.參照第 01 頁固定調整

保固期限：壹年，日期如無法查證時以出廠日期起18個月為準確（不含時規皮帶）

Situation	Reason	Solution
Vibration	1. Fixed screw loosen.	1. Refer to the page 2
No signal	1. Power is not connecting properly. 2. Connecting wire is break. 3. Electronic control system error.	1. Refer to the page 4 2. Refer to the page 4, please check the pin of connecting plug or socket are not loose. 3. Please call the technician to maintain
Blank panel	1. Panel out of order.	1. Please call the technician to maintain
Cannot memory the Mode	1. Memory out of order.	1. Please call the technician to maintain
Inserting tape difficulty	1. Wrong position for the tape or the main device. 2. The air jet hole is in the wrong position or too less jet air.	1. Refer to the page 01 2. Refer to the page 01

Warranty: One year, or 18 months after manufactured date. (Timing belt is not under warranty)

