

Vision Cutting Series Machine

For: SM960/SM960F

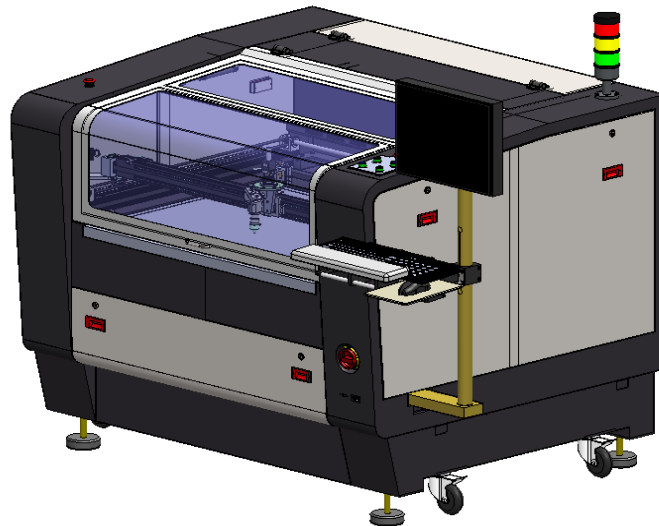

Owner's Manual

This owner's manual is suitable for:

- Laser machine designer
- Laser machine operator

Copyright Statement

Our company

All rights reserved.

Our company reserves the right to modify the products and product specifications described in this manual without advance notice.

Our company is not responsible to any direct, indirect, or consequential damage or liability caused by improper use of this manual or the product.

Our company owns the patent, copyright or any other intellectual property right of this product and the related software. No one shall duplicate, reproduce, process or use this product and its parts, unless authorized by our company.

All the name referred in this manual only for identification, if belongs to other company's registered trademark or copyright, proprietary rights of the name belongs to their respective holder.

Disclaimer and Responsibility Statement

Whole using the machine from our company, users are required to ensure integrity and independence of the product including but not limited to: mechanical, electrical, optical, control software and accessories. Unauthorized modification is strictly prohibited. It is a must to satisfy operating environment and operating specifications specified in the owner's manual.

For the followings:

1. Machine modified with no authorization (including but not limited to: add, remove, modify, unauthorized disassembly, replacing parts);
2. Use the machine in the environment failing to satisfy the operating requirements;
3. Operate disobeying the specifications of our company;
4. Unauthorized use the machine parts, accessories and auxiliaries on to other machine or in other places;
5. Viciously disassemble, destroy, decode hardware and software of the machine from our company

Our company shall not undertake any direct, indirect or joint responsibility. Our company reserves the rights to ascertain legal responsibility for the serious consequences or economic losses or reputation losses caused by what mentioned above.

Foreword

Thanks for purchasing the laser engraving machine control system of our company.

Before operating, please read this manual carefully to ensure proper operation.

Please keep the manual properly for reference.

Since the configs are different, certain models do not have the functions listed in this manual. Please refer to the specific functions for details.







Due to the constantly tech update, the specification for reference only, subject to the real standard.

Tags in this book:

	Special Attention: User must follow and perform as the manual; otherwise, it could lead to errors or relatively serious problem.
Alarm	

	Note: User should comply with the attention and suggestion in this manual; it could bring much easier operation.
Note	

Safety Precautions

 Attention	<ul style="list-style-type: none"> ◆ Before using the machine, users are required to carefully read this manual and other operating requirements, strictly abide by the operating specifications. Professional are required for operating the machine.
 Attention	<ul style="list-style-type: none"> ◆ The machine uses class 4 laser (strong laser radiation). The laser radiation may possibly cause the following accidents: ① emblaze the surrounded flammable materials; ② generate other radiations and toxic or hazardous gas by processed objects during laser processing; ③ direct irradiation of laser radiation cause harm to human body. Therefore, fire fighting devices are required in the operating place of the machine. Stacking flammable or explosive objects near the machine is strictly prohibited. Good ventilation is a must. Only the qualified personnel are authorized to approach the machine.
 Attention	<ul style="list-style-type: none"> ◆ The processed objects and discharged materials are required to satisfy requirements as per local laws and regulations.
 Attention	<ul style="list-style-type: none"> ◆ Laser processing is with potential risks. Users should carefully make sure if the processed objects are suitable for laser processing. ◆ There is high voltage and potential risk in the laser machine. Unauthorized disassembly by unqualified personnel is prohibited. ◆ Reliable earthing is required for the machine and related other machine before power-on. ◆ During operating, removing any cover of the machine is strictly prohibited. ◆ During operating, the operators are required to observe working status of the machine all the time. In case of any abnormality, it is immediately to disconnect power supply and take active and corresponding measures. ◆ After power-on, special personnel are required for monitoring. Unauthorized leaving is strictly prohibited. ◆ It is a must to disconnect the power supply before leaving.
 Attention	<ul style="list-style-type: none"> ◆ It is strictly prohibited to placing any unrelated all-reflective or diffusion reflective objects in the machine to prevent laser reflecting to human body or flammable materials.
 Attention	<ul style="list-style-type: none"> ◆ The environment for the machine should be dry, free of interference and influences from pollution, vibration, high voltage and strong magnet. The operating ambient temperature ranges 5-40℃, and the humidity ranges 5-95% (no dew); ◆ The machine should be far from electric appliances sensitive to electromagnetic interference;

	◆ Operating voltage: AC220V, 50Hz. Power-on is strictly prohibited in case of unstable voltage of the power grid or unspecified voltage.
 Attention	Chapter two of this manual is for <i>Safety Rules</i> . Please refer to the chapter more details concerning safe operation of the machine. Users are required to carefully read and abide by all the requirements of safety.

Contents

Copyright Statement.....	I
Disclaimer and Responsibility Statement.....	II
Foreword	III
Safety Precautions.....	IV
Chapter 1 Machine Introduction	- 1 -
1.1 Instructions of machine model	- 1 -
1.2 Machine compositions	- 1 -
1.2.1 Compositions of the machine	- 1 -
1.2.2 Compositions of movement mechanism	- 4 -
1.2.3 Compositions of optical mechanism.....	- 5 -
1.2.4 Machine visual mechanism.....	- 5 -
1.2.5 Working platform.....	- 6 -
1.2.6 Auxiliary parts	- 7 -
1.3 Machine parameters	- 7 -
1.4 System configuration.....	- 10 -
1.5 Operating environment.....	- 10 -
1.6 Suitable materials.....	- 11 -
1.7 Applicable fields.....	- 11 -
Chapter 2 Safety Rules.....	- 12 -
2.1 Product safety.....	- 12 -
2.2 Safe equipment	- 12 -
2.3 Safety awareness.....	- 12 -
2.4 Requirements for personnel.....	- 13 -
2.4.1 Definition of terms.....	- 13 -
2.4.2 Qualifications	- 13 -
2.4.3 Responsibility	- 13 -
2.4.4 Personal protective devices.....	- 13 -
2.5 Special product risks.....	- 14 -

2.5.1	Laser radiation risk.....	- 14 -
2.5.2	High voltage risk.....	- 16 -
2.5.3	Risk of electric shock.....	- 16 -
2.5.4	Hazard of processing outgrowth.....	- 17 -
2.5.5	Risk of optical system.....	18
2.5.6	Other risks.....	19
2.5.7	Measures for emergency.....	19
Chapter 3 Machine Installation and Debugging.....		20
3.1	Machine Installation.....	20
3.1.1	Steps of unpacking.....	20
3.1.2	Unpacking check.....	21
3.1.3	Preparations for machine installation.....	22
3.1.4	Steps of installation.....	23
3.2	Instructions of machine button and indicator light.....	36
3.2.1	Power switch.....	36
3.2.2	Emergent stop button.....	37
3.2.3	Power supply control panel.....	37
3.2.4	Three-color indicator light.....	39
3.3	Machine debugging.....	40
3.3.1	Sequence of power-on and power-off.....	40
3.3.2	Movement debugging.....	41
3.3.3	Laser debugging.....	44
3.3.4	Machine vision debugging.....	47
3.3.5	Trial operation of processing.....	47
Chapter 4 System Maintenance.....		49
4.1	Mechanical maintenance.....	49
4.1.1	Guide rail, linear shaft, slide block assembly (metal guide pulley), nylon guide pulley	49
4.1.2	Synchronous belt, synchronous belt wheel.....	50
4.1.3	Fasten screws and coupling.....	51

4.2	Electric maintenance	51
4.2.1	Limit switch	51
4.2.2	Stop button	51
4.2.3	Maintenance of other button and indicators	52
4.3	Light route and optics parts maintenance.....	52
4.4	Machine visual maintenance.....	53
4.5	Auxiliary parts maintenance	53
4.5.1	Water replacement and water tank cleaning	53
4.5.2	Blower cleaning.....	54
4.5.3	Water chiller maintenance	54
Chapter 5 Trouble Shooting.....		55
Appendix.....		57
Appendix 1 Electric control system figure.....		57
Appendix 2 The control elements figure of main power supply		58
Post.....		- 59 -

Chapter 1 Machine Introduction

SM960 series laser machine is an automatic laser brand cutting machine base on machine vision developed by our company. The machine is mainly equipped with sealed max. 200W CO2 glass laser tube or within 50W metal radio-frequency tube with the function of lookup and processing the brand of small clothes and with the wide scope of application in the brand field of cloth, toy, embroider. It is a laser cutting machine with high precision, high capability and high automatization.

1.1 Instructions of machine model

Indications of our company's machine model:

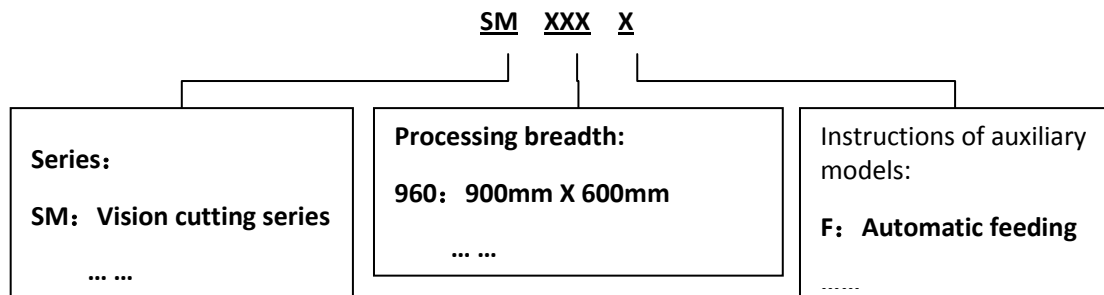

Fig.1-1 Instruction of machine model

1.2 Machine compositions

Due to different models and improvement of products, the industrial design and details of some types of machine may be different. The compositions are subject to the actual product. The following takes general SM960 as an example for the compositions of the machine.

1.2.1 Compositions of the machine

✧ Front view of the machine is as shown in the figure below:

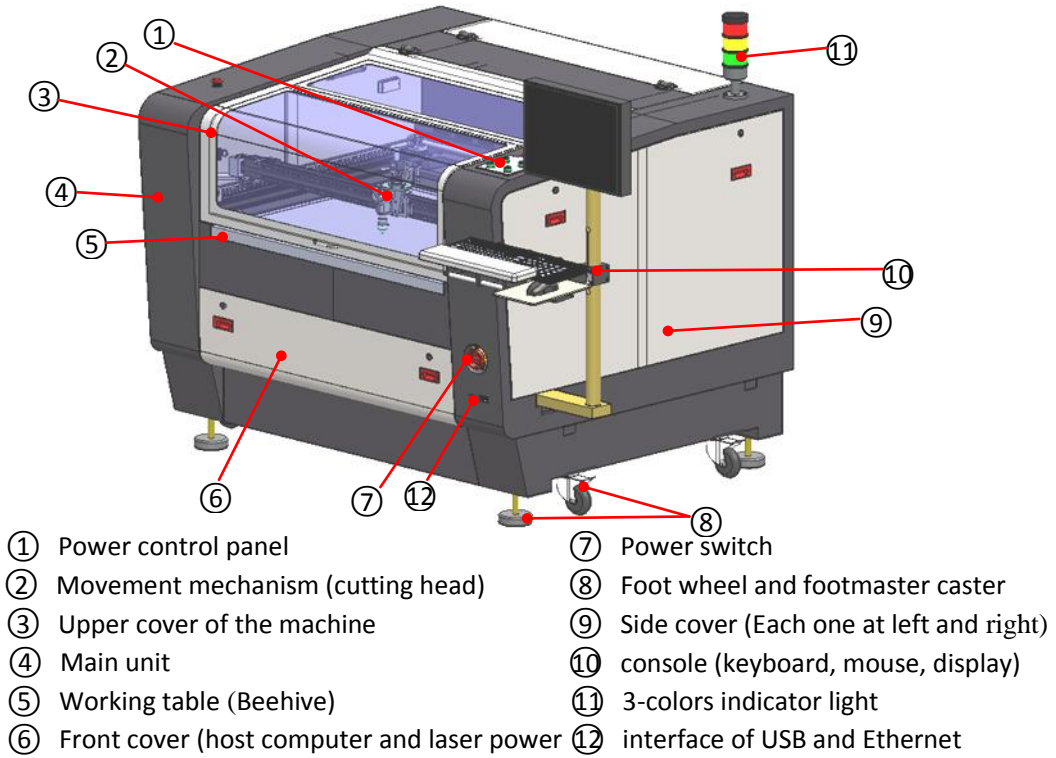

Fig.1-2 Front view of the machine

✧ Back view of the machine is as shown in the figure below:

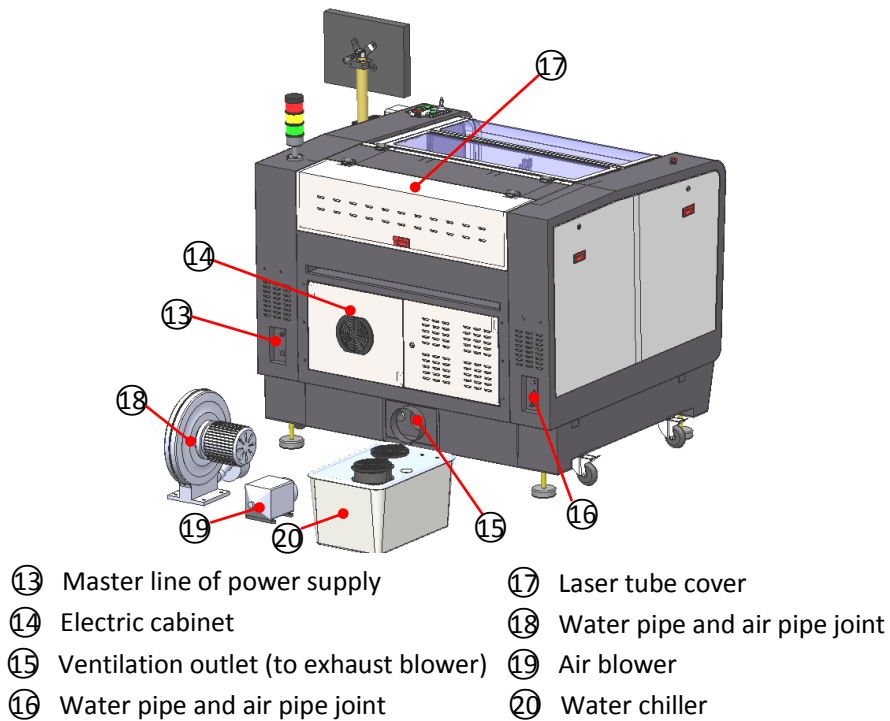

Fig.1-3 Back view of the machine

✧ The vision cutting machine with automatic feeding (SM960F) shown as follow:

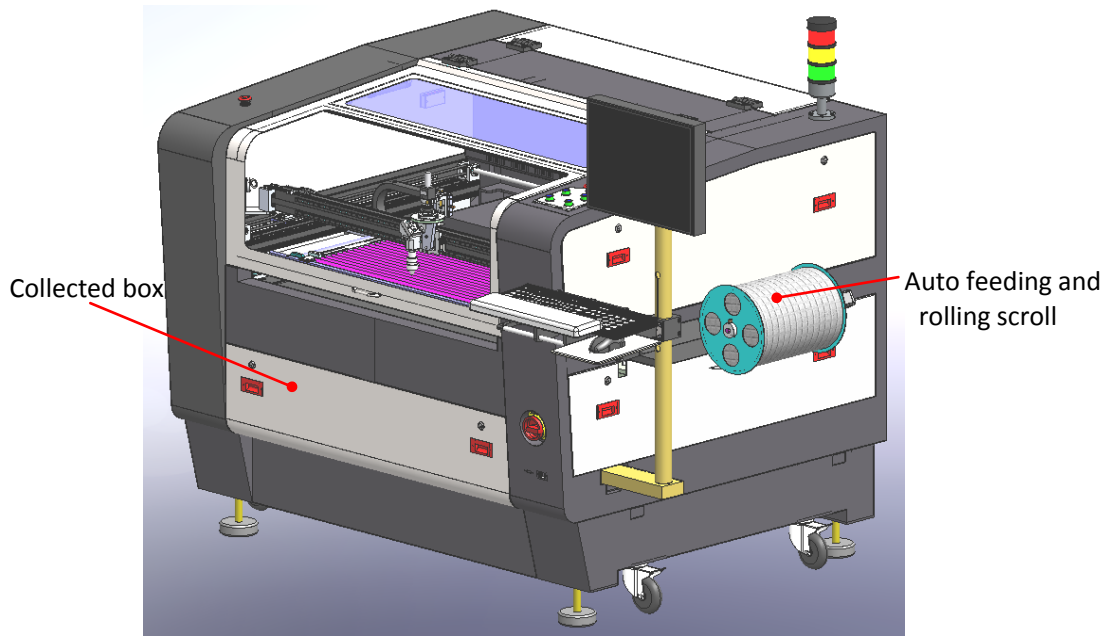

Fig.1-4 The vision cutting machine with automatic feeding(SM960F)

✧ Machine control is as shown in the figure below:

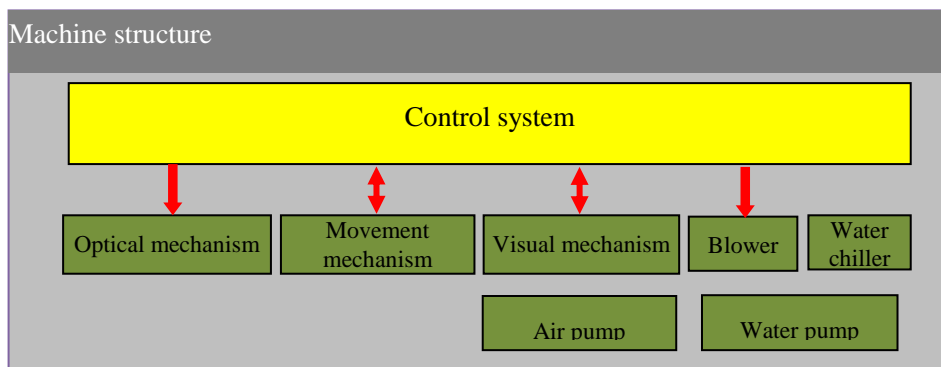
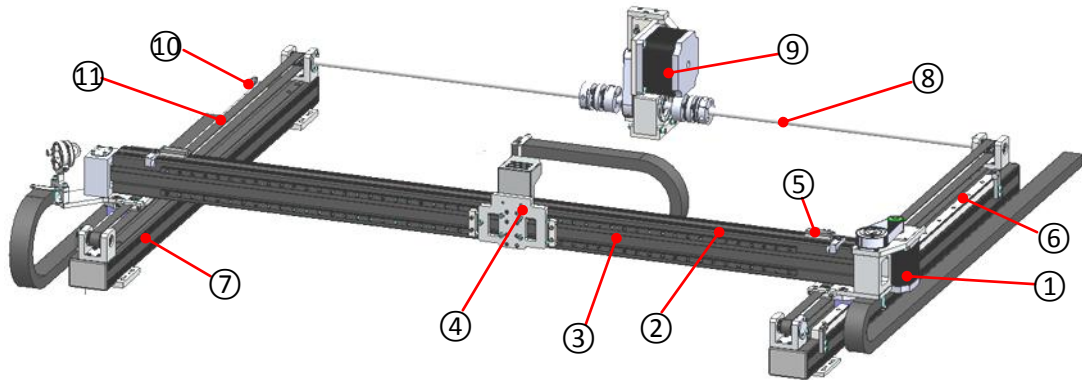

Fig.1-5 Illustration of machine control

1.2.2 Compositions of movement mechanism

✧ Plane movement mechanism is composed of X-axis and Y-axis movement mechanisms in vertical relation as shown in the figure below:



- | | |
|--|---|
| ① X-axis motor | ⑦ Y-axis guide rail beam (each one at left and right) |
| ② X-axis beam and guide rail | ⑧ Y-axis drive shaft |
| ③ X-axis timing belt | ⑨ Y-axis motor |
| ④ Dolly (connecting to cutting head) | ⑩ Y-axis sensor (Reset or limit signal) |
| ⑤ X-axis sensor (Reset or limit signal) | ⑪ Y-axis timing belt (each one at left and right) |
| ⑥ Y-axis guide rail (each one at left and right) | |

Fig.1-6 Illustration of plane movement mechanism

✧ Feeding mechanism of automatic feeding machine shown as below:

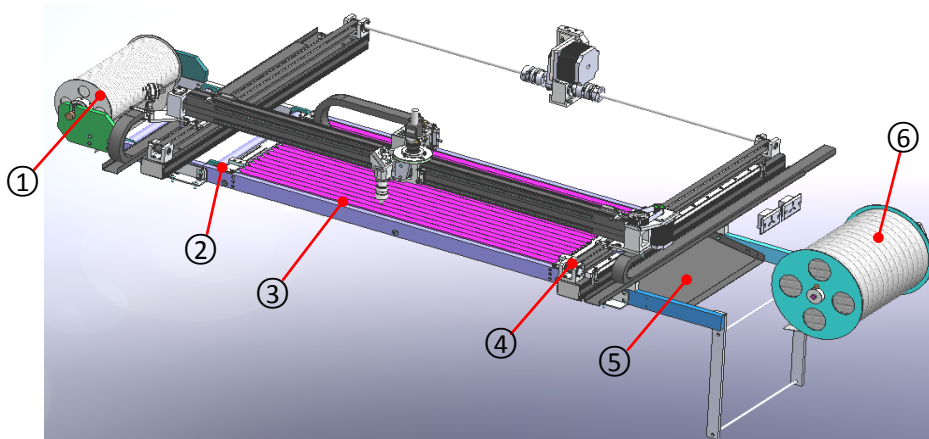

- | | |
|-----------------------------------|------------------------------|
| ① Feeding shelves | ④ Feeding transmission shaft |
| ② Feeding blocker | ⑤ Material outlet |
| ③ Cutting table (strip soleplate) | ⑥ Rolling scroll |

Fig.1-7 Automatic feeding mechanism

1.2.3 Compositions of optical mechanism

SM series laser machine is single-path laser light route, the light route mechanism as the following figure:

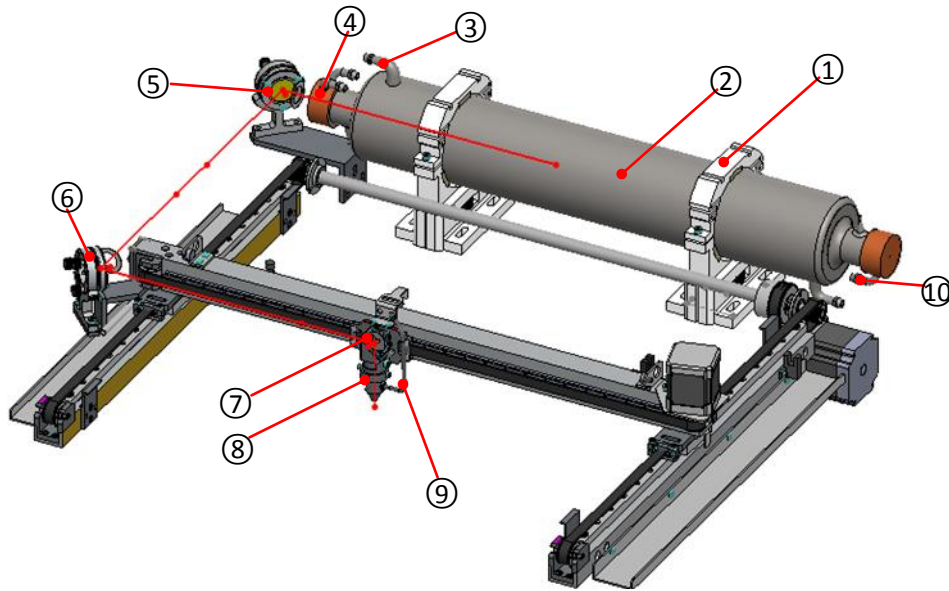

- | | |
|---|-------------------------------|
| ① Laser tube bracket | ⑥ No. 2 reflector |
| ② Laser tube | ⑦ No. 3 reflector |
| ③ Water circulation joint (an outlet and inlet) | ⑧ Focus |
| ④ Laser outlet | ⑨ Blowing pipe |
| ⑤ No. 1 reflector | ⑩ High voltage line connector |

Fig.1-8 Machine optical mechanism

1.2.4 Machine visual mechanism

The structure of the visual mechanism is as shown in the figure below:

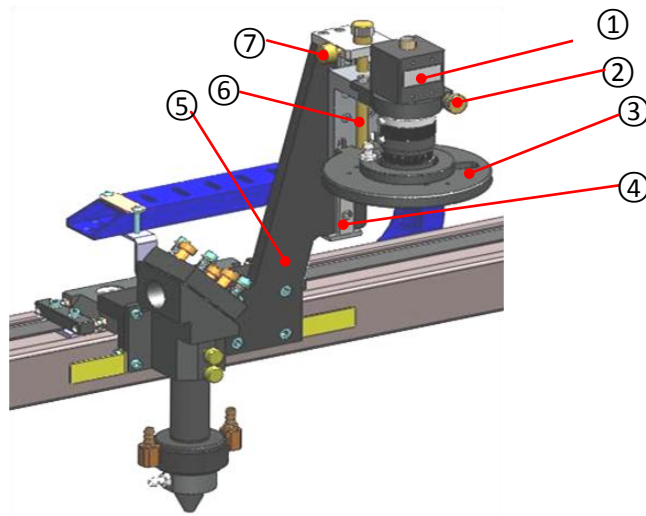

- | | |
|-------------------------------------|---------------------------------|
| ① Industrial camera (lens included) | ⑤ Installation connecting board |
| ② Camera fixation screw | ⑥ Lift bolt |
| ③ LED light source | ⑦ Lift lockup bolt |
| ④ Lift guide rail | |

Fig.1-9 Machine visual mechanism

1.2.5 Working platform

Working platforms of SM series laser machine are mainly beehive soleplate or strip soleplate. Some types of machine with higher requirements for absorption are equipped with vacuum absorption platform. Beehive soleplate is mainly used for placing soft materials like cloth or leather, while strip soleplate is mainly for hard materials like organic glass or thick plank.

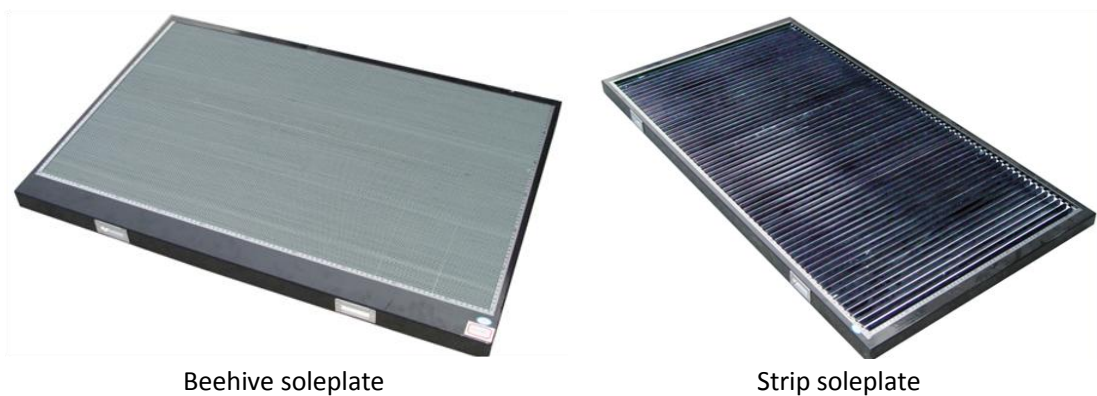

Fig.1-10

1.2.6 Auxiliary parts

To ensure normal operation, the laser machine needs also some auxiliary parts like blower, air pump and water tank. Different types of machine are with different auxiliary parts, and those are subject to the actual machine.

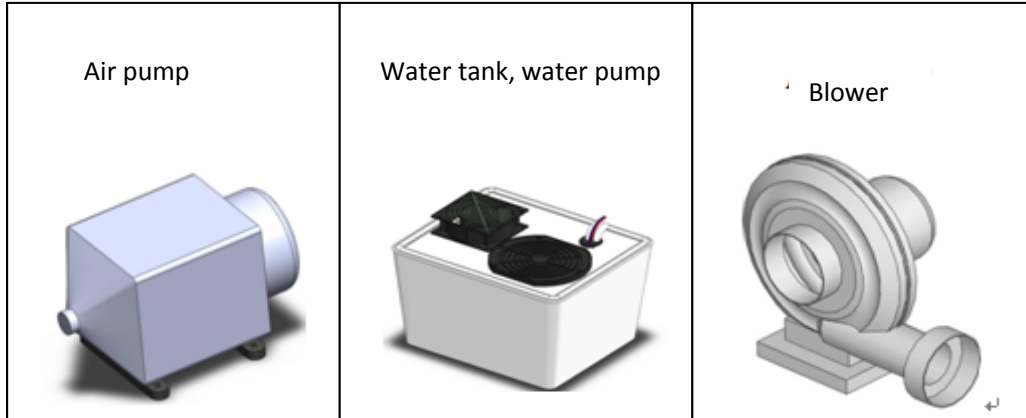

Fig.1-11 Auxiliary parts

1.3 Machine parameters

Machine parameters quite differ from each other due to different types and configurations. The parameters are subject to the ex-factory nameplate attached to the machine. The nameplate is generally stuck to the back or left side of the machine. The following is a nameplate of SM960 type:



Fig.1-12 Machine nameplate

Instructions of each parameter on the nameplate of the machine:

- Machine name: name of the machine;

- Machine type: type of the machine. Refer to section 1.1 in this manual for instructions of machine type;
- Laser type: laser type configured on the machine mainly including two types as CO₂ and YAG;
- Laser power: Rated power of the laser machine;
- Total power: the rated power during working;
- Power supply: the master imputer power supply of the machine. They are generally AC220V. However, the exported types differ from each other due to the countries exported to;
- Series No.: the unique number of each machine;
- Manufacture: the date on which the machine is produced;

In addition, each device is attached with an independent ex-factory parameter list usually stuck on the inner part of right end cover of the machine. The parameter lists are different from each other due to the differences of type of machine and configured controller. The following is a parameter list for SM960:

Type IV machine ex-factory parameter list								
Item	<input type="checkbox"/> A axis		<input type="checkbox"/> Z axis		√Y axis		√X axis	
(pulse/mm)	/		/		178.98		178.82	
Max. stroke (mm)	/		/		600		900	
Control method	/		/		P+D		P+D	
Max. speed (mm/s)	/		/		300		400	
Max. acceleration (mm/s ²)	/		/		5000		16000	
Reset direction	/		/		-		+	
Zero (limit) level (Note 1)	Algorism numerical value (240)							
	-	+	-	+	-	+	-	+
	1	1	1	1	0	0	0	0
	√Laser head 1				<input type="checkbox"/> Laser head 2			
Power control signal	<input type="checkbox"/> PWM <input type="checkbox"/> Frequency √Analog				<input type="checkbox"/> PWM <input type="checkbox"/> Frequency <input type="checkbox"/> Analog			
Energy regulation method	√Dynamic energy <input type="checkbox"/> Constant Energy				<input type="checkbox"/> Dynamic energy <input type="checkbox"/> Constant Energy			
PWM frequency (Hz)	/				/			

(Note 2)		
Pre-voltage (V) (Note 2)	1.0	
Focus (mm)	63.5	
Space between two laser heads (mm)		
<p>Note 1: level trigger signal; high level trigger is 0, low level trigger is 1, and suspension is 1;</p> <p>Note 2: when power control signal is PWM, PWM power setting is required; when control signal is analog, pre-voltage setting is required.</p>		

Table1-1 Ex-factory parameters of No.4 controller

The above is a parameter list of No.4 controller (for SM960), and the followings are an introduction to the parameters:

- Pulse equivalent: Pulse required for each 1mm forward of the movement shaft. Correctness of movement length is depended on this parameter;
- Max. stroke: The maximum stroke of each movement shaft of the machine;
- Control method: Control methods differ from each other due to different motors configured, and general method is pulse + direction mode (P+D);
- Max. speed: The maximum movement speed of each movement shaft. Speed beyond this value may possibly cause failure of motion to the machine;
- Max. acceleration: The maximum acceleration of each movement shaft. Acceleration beyond this value may possibly cause failure of motion to the machine;
- Reset direct: Reset direction of the machine. Aero position may differ due to different machine;
- Zero (limit) level: Trigger level of sensor differs due to different types of machine and configurations. Setting based on actual need is required;
- Power control signal: Power control method of laser device including PWM, frequency and analog;
- Energy regulating method: Energy regulating method during cutting and processing including dynamic energy and constant energy;
- PWM frequency: When the configured laser device is a metal radio frequency tube, this parameter is required to be set;
- Pre-voltage: When the configured laser device is a glass tube, and laser power control signal is an analog, this parameter is required to be set;
- Focus: Set it according to model of focus lens configured on the machine, and it indicates focus of the focus lens;
- Space between two laser heads: Electric dual-laser head machine is required to set this parameter, and it indicates the minimum space between the two laser heads;

 Note	Please refer to <i>User Manual of 4th Control System</i> for more details.
---	---

1.4 System configuration

Component	Parts	Type	Manufacturer	Note
Movement system	Motor	Step	China-made or imported	Optional
	Transmission mechanism	Timing belt	China-made or imported	Optional
	Guide rail	linear guide rail	China-made or imported	
Optical system	Reflector	Molybdenum reflector	imported	
	Focus lens	75、63.5、50.8	China-made or imported	Optional
Visual system	Industrial camera	CCD 130W	imported	
	camera lens	3X	imported	Low aberration
	Collection card	1394B	imported	
Pneumatic system	Exhaust blower	350W	China	Optional
	Air blower pump	Large, medium, small	China	Optional
Cooling system	Water tank +water pump	Water tank, industrial water chiller	China	Optional
Control system	Controller	No. IV controller	Our company	
	Control software	SmartCarve4 series	Our company	
Dust disposal	Dust and smoke collector		China	Optional

Table1-2 System configuration list

1.5 Operating environment

- Humidity: 5%~95% (no dew)
- Temperature: 5℃-40℃
- Power supply: AC220V;50/60Hz
- Earthing: Grounding resistance should be less than 5Ω
- Environment of the machine should be dry, and free of interference like dust, pollution, vibration, high power and strong magnetic field;
- Air pressure: 86-106kpa
- Working table load capacity: 50Kg/m²

1.6 **Suitable materials**

SM960 series machine are suitable for the materials with good absorption of CO2 laser, e.g. non-metal material like cloth, leather, organic glass, wooden product, plastic, rubber ceramic tile, crystal, boulder, and bamboo product.

1.7 **Applicable fields**

SM960 series machine are applicable for professional users with high requirements for carving and cutting effect in the industry of garment, leather, cloth toy, computerized embroidery, electronics and electrics, model, craft, advertisement decoration, building decoration, package printing, and paper product.

Chapter 2 Safety Rules

This chapter mainly introduces safety warnings for protecting personnel and the machine. The machine is already equipped with sufficient safety guarantee, yet it is still with certain risk. All the operators are required to carefully read through and well understand the safety rules.

2.1 Product safety

The following conditions are required to be satisfied to ensure safe work:

- Abide by operation manual and instruction signs;
- Operators and maintenance personnel have received training held by machine manufacture;
- In case of operation by couples of person at the same time, division of responsibility should be made and followed;
- No admission to the working area for the unauthorized personnel;
- Avoid any working method breaking the safety rules;
- Timely eliminate all the failures possibly causing lower safety coefficient;
- Abide by maintenance regulations of the machine.

2.2 Safe equipment

Safety machines are used for protecting personnel, and unauthorized disassembly, bridge-group or by-pass connection are strictly prohibited; in case of failure with the safety machine, professional are required for repair. If part replacement is needed, the product with same model, specification and from the same manufacture is required; otherwise, written consent from the manufacturer is required.

2.3 Safety awareness

The machine can be operated only by skilled personnel or under supervision of them. Improper use or operation may possibly be very dangerous and cause damage to the machine. Therefore, the followings are strictly prohibited:

- Placing heavy objects or stepping on the working table of the machine;
- Used for processing the materials unapproved by manufacturer;
- Staying of unauthorized personnel in the dangerous area (It is the responsibility of operators to ensure keeping unauthorized personnel away from the working area.);
- Block of using emergency stop button (Regular check is required to ensure a good condition for the emergency stop button.);

2.4 Requirements for personnel

After trial operation, maintenance personnel from the manufacturer may perform training on the operators;

It is the responsibility of machine owner to have operators trained at corresponding level;

We have prepared ready a series of training course for your option. Please make phone call to our **Customer Training Center** for details.

2.4.1 Definition of terms

All the personnel using or operating the machine are called **User** in the manual;

Different requirements are for different users. Users are classified into the followings:

- Owner

Owner means the authorized person or representative to sign contract with the manufacturer. With authorization, the owner has rights to sign the agreement with binding force of law;

- Operator

Operator means the personnel trained for operating the machine. Training of the operator includes participation of training held by the manufacturer.

- Maintenance personnel

Maintenance personnel mean the technicians having received formal training for machine and electric engineering. The maintenance personnel are responsible for daily maintenance of the machine, and repair at low level if needed. Training on the maintenance personnel contains participation training held by manufacturer.

2.4.2 Qualifications

The operator is required to accept guidance and training of the owner, and the operator is responsible for the safety of a third party in the working area; the personnel required for further training and guidance are required work or operate the machine under supervision of the operators.

2.4.3 Responsibility

It is a must to clarify the related responsibilities of each performance (operation, maintenance, parameter setting), and carry it out. Unclassified responsibilities will cause safety hidden risks.

Owner is required to provide operation manual for the operators and maintenance personnel, and ensure that they have read and understood the operation manual.

2.4.4 Personal protective devices

When technology or measures fail to absolutely avoid risk of health, the owner is required to provide personal protective devices for operator and maintenance personnel. For example,

- Boot with steel cover
- Protective gloves
- Laser-proof goggle
- Light respirator

 Tips	Personal protective devices shall not be provided together with the machine.
---	--

2.5 Special product risks

2.5.1 Laser radiation risk

Based on level of potential risk of laser radiation, the national standard GB 7247.1-2001 makes classification for them. Laser class applicable for this laser cutting machine depends on operation mode. The followings are abstract of laser device classification prescribed by the state:

Class 1: safe laser device under reasonable and foreseeable working conditions

Class 2: laser device emitting visible light at wave length of 400nm-700nm. Generally, avoidance response including blink reflection provides protection;

Class 3A: safe laser light visible to naked eyes. Generally, avoidance response including blink reflection provides protection. Harm to naked eyes of other wave lengths will be less Class 1 laser device. Class 3A light beam internal observation with optical device (e.g. glasses, telescope, microscope) may be dangerous.

Class 3B: dangerous laser device is to directly and internally see light beam. Generally, observation of diffuse reflection is safe.

Class 4: laser device with diffuse reflection causes danger. They may possibly cause skin burn, or fire accident. Great care is required to use this kind of laser device.

2.5.1.1 Common mode

In the normal operating mode, the laser cutting machine equals to Class 1 laser radiation. In this operating mode, there will no harm of laser radiation to eyes and skin; however, you are recommended to wear goggles with antiglare filter in case of long-term exposure to cutting light beam.

 Tips	<ul style="list-style-type: none"> ● It is a must to ensure normal operating mode; ● Correct installation of all protective covers; ● Keep upper cover of crossbeam closed; ● Correct operation of the laser cutting machine; ● Materials to be processed have been verified suitable for CO₂ laser processing
---	--

2.5.1.2 Maintenance mode

In case of having opened the safety cover (e.g. door) or having removed (e.g. crossbeam cover) or short connected of the crossbeam protective cover and crossbeam organic glass cover opened, the laser cutting machine is in a maintenance mode, no matter the purpose of the operation is for checking work, cleaning or maintenance.

 Attention	<p>In maintenance mode, laser radiation is not entirely shielded. At this time, the laser cutting machine equals to Class laser device radiation. Direct laser beam and reflection radiation will cause unrecoverable harm or skin burn.</p> <ul style="list-style-type: none"> ● The operation at this time can only be performed by trained and qualified maintenance personnel; ● All the unauthorized and unqualified personnel are prohibited to come into the dangerous area; ● Cover or remove the reflective objects; ● Remove the flammable materials; ● Avoid generation of explosive solvent gas; ● Wear laser-proof glasses
--	---

2.5.1.3 Direct laser

You are required to pay attention to the followings while operating the laser machine:

- It is strictly prohibited to directly expose any parts of human body, explosive object and flammable objects to direct laser;
- Modification of fasteners on the optical parts is strictly prohibited;
- Unauthorized change of light route is strictly prohibited;
- Abide by all instructions prescribed in the operation manual.

2.5.1.4 Reflection and diffuse radiation

Avoid exposing eyes and skin to mirror reflection and diffuse radiation. In the maintenance mode, the maintenance personnel are required to wear laser-proof glasses, and the laser-proof glasses should satisfy the requirements as per **EU standard EN207A1:2002**.

Version of glasses waering



Standard design



Fig.2-1 Picture of laser-proof glasses

 Tips	Wavelength of CO2 laser device of this class is 10.6 micron and light density is 4+; You are recommended to use SD-5 type of protective glasses made by Shield Company.
---	--

 Attention	<ul style="list-style-type: none"> You are prohibited to directly watch strong light and laser even with laser-proof glasses on; Laser-proof glasses are made from high polymer material, and dipping into organic solvent or cleaning with it are prohibited; It is a must to replace the laser-proof glasses at the expiration.
--	--

2.5.2 High voltage risk

Laser module (laser power supply and its high voltage line) will generate high voltage at 15,000V. There is the risk of electric shock.

 Attention	High voltage 15,000V! The voltage over 50V and the current over 20mA are with the risk of danger and may cause death. Only the maintenance personnel from the manufacturer are permitted to perform operation on the inner parts.
--	--

2.5.3 Risk of electric shock

 Attention	<p>While operating electric machine or device, mis-operation or neglect during operation may possibly cause serious hurt or human body or even death;</p> <p>Technicians with related qualifications are required for operating the electric machine or device or perform operation under their supervision.</p>
--	--

The followings are required for operating of installing the electric machine:

- It is a must to use the specified fuse provided by the manufacture;
- Immediate disconnection of power supply is required in case of power failure;
- Unless otherwise prescribed, power disconnection of the electric part is required for maintenance;
- First check if there is live power on the insulated part, and then perform the treatment of earthing and open circuit, and perform insulation for the nearby live (charge) parts;
- Make regular check on the electric equipment. Timely correct failure like poor contact or burnt power cord;
- While operating live (charge) parts, minimum two persons are required at the site for pressing the emergency stop button or disconnecting power supply if necessary; Mark the working area with red-and-white band and warning sign;
- It is a must to use insulation tools.

2.5.4 Hazard of processing outgrowth

During laser processing, outgrowth may possibly generated, and their hazard must satisfy the requirements specified in Appendix A for example of processing outgrowth as national standard GB 18490-2001 laser processing machine. The abstract is as below:

✧ ceramic processing

Al₂O₃, Mg, oxide of Ca and Si; BeO (virulent poison);

✧ silicon slice processing

Crumb of silicon and silicon monoxide suspended in the air (possibly breathed into lungs causing silicosis);

✧ metal processing

In a view of iatrology, minimum the following metals and their compounds are influential: Mn, Ni, Co, Al, Zn, Cu, Be, Pb, Sb

Medical influences are as below:

Toxic	Cr ⁶⁻ , Mn, Co
Allergic reaction, burn caused by metal smoke	Zn, Cu
Lung fibrosis	Be
Carcinogenesis	Cr ⁶⁺ , NiO

Metal beryllium is very dangerous, especially cutting alloy or metal containing Zn in open air will generate heavy metal smoke.

✧ Plastic cutting

When cutting plastics, various kinds of substances with potential risks may be generated. At lower temperature, aliphatic hydrocarbon is produced; at higher temperature, aromatic hydrocarbon (e.g. benzene PAH) and polyhalo-polynuclear hydrocarbon (e.g. dioxin, furan) are increased. Some of these substances may possibly generate cyanide, isocyanate (PU), acrylate (PMMA) and hydrogen chloride (PVC).

Medical influences include:

-----Toxic: Cyanide, CO, derivative of benzene

----- Allergy source/irritation: isocyanate, acrylate

----- Respiratorytract irritation: formaldehyde, acradehyde, amine;

----- Carcinogenesis: benzene, some PAH substances

✧ Surface modification

Generally, there is no noticeable outgrowth, but sometimes heavy metal steam is generated.

✧ Cutting paper and wood

General fibrin outgrowth, ester, acid ethanol, benzene

 Attention	<ul style="list-style-type: none"> ● During laser cutting, the smoke generated may be very toxic. The smoke is removed by upper exhaust blower system; ● Cutting with abnormal blower system is prohibited.
--	---

 Note	<ul style="list-style-type: none"> ● Make frequent check on the ventilation system; ● Make regular cleaning and maintenance for the ventilation system; ● Foreign matter coming into duct of the ventilation system is strictly prohibited; ● Ensure a good ventilation and a through removal of exhaust air in the working room; ● Ensure a necessary disposal of the exhaust air to satisfy emission requirements prescribed by the state and local government
---	---

2.5.5 Risk of optical system

2.5.5.1 Routine operation

The reflector of the optical system is the gold plating silicon reflector, and the focus of the cutting head is made from zinc selenide. In normal condition, these optical parts are free of danger.

However, polluted focus or focus with damaged coating will cause thermal decomposition by laser beam over 400°C together with toxic smoke generated. At this time, the laser device must be powered off, mechanical movement and blowing air to the lens must be stopped. At this moment, cleaning and parts replacement should be performed.

When gold plating silicon reflector is decomposed by high temperature laser beam due to pollution or damaged coating, the decomposition will generate dust and smoke containing silicone monoxide, steam of heavy metal. At this time, it is a must to power the laser device off, stop running the machine and keep good ventilation. When all the smoke and dust are removed, it is to perform cleaning and replacement of lens.

 Tips	<p>During cleaning, please wear on goggle and gloves. The damaged parts must be sealed in a container and properly packaged, and then returned to the manufacturer. Good ventilation is required in case of any damage of the parts.</p>
---	--

2.5.5.2 Warning for fire accident

Damaged machine or improper operation of the machine will cause risk of fire accident. Fire extinguisher must be equipped according to fire control regulations prescribed by the state.

 Attention	<p>Atomizer or flammable or explosive substances are strictly prohibited to approach the machine, make regular check on the fire extinguishers to ensure a good condition.</p>
--	--

2.5.6 Other risks

To ensure safety, modification or changing use of the machine with no consent from the manufacturer is strictly prohibited; any change of operating software or function to the machine is strictly prohibited, or it is strictly prohibited to perform integration of the machine with other system.

2.5.7 Measures for emergency

2.5.7.1 Measures for personal injury

In case of personal injury, the followings should be performed:

- Stop hurting (e.g. stop the machine, disconnect the power supply)
- It is a must to take first aid measures;
- Notify professional medical personnel;
- Notify the competent management department;
- Abide by the related regulations prescribed by the state and the company

2.5.7.2 Measures for fire accident

In case of fire accident, the following measures should taken:

- Emergency stop of the machine, disconnection of power supply;
- Control of fire with the fire extinguisher, evacuation of personnel;
- Notify the competent management department;
- Abide by the related regulations prescribed by the state and the company

Chapter 3 Machine Installation and Debugging

3.1 Machine Installation

3.1.1 Steps of unpacking

Before installation, unpacking the wooden box for the machine from our company is needed in the following steps:

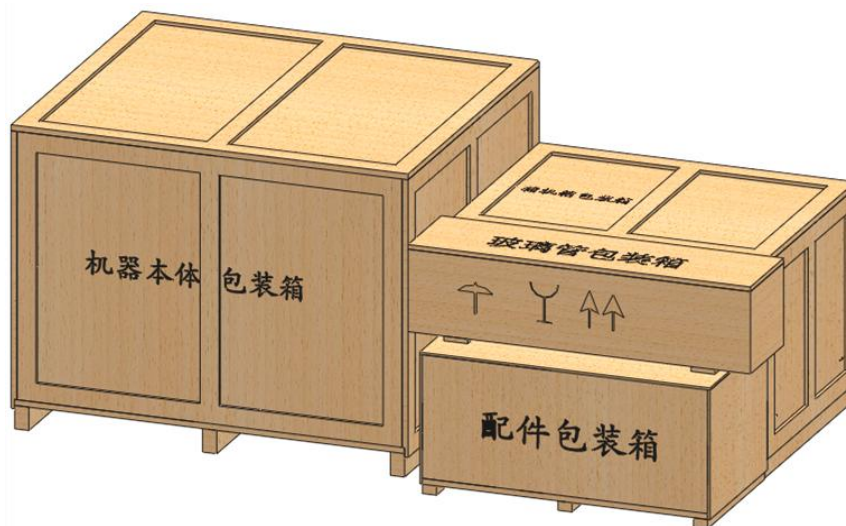

Fig.3-1 Machine wooden box

- 1. Remove wooden box with a crowbar (prepared by user), the steps are the upper cover, left, right, front and back wood plank, the plank for fixing foot caster.

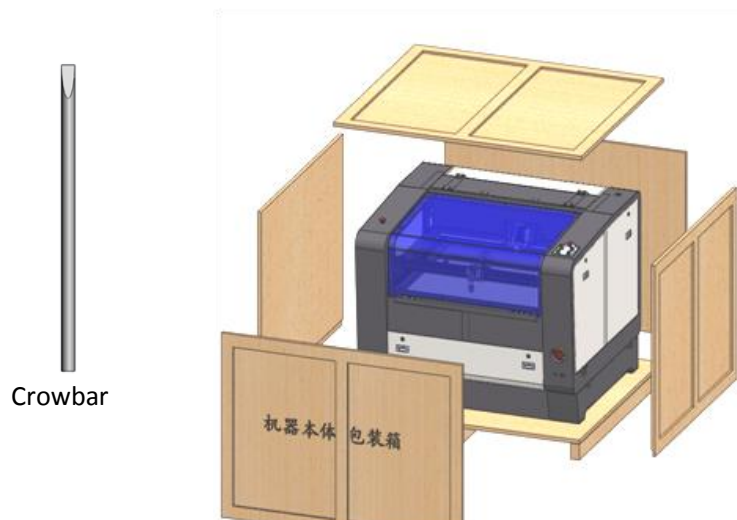

Fig.3-2

- 2. Unfasten the screw on upper part of the foot caster with a wrench and lift the foot caster to keep a distance to the pallet larger than to the multi-direction foot wheel;

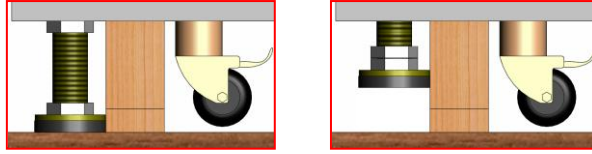

Fig.3-3 Unfasten the foot wheel and foot caster

- 3. Lift the machine from the pallet with forklift and move the destination; and let down the foot caster to riveting.
- 4. Then open up the packing box of laser tube and auxiliary machine box

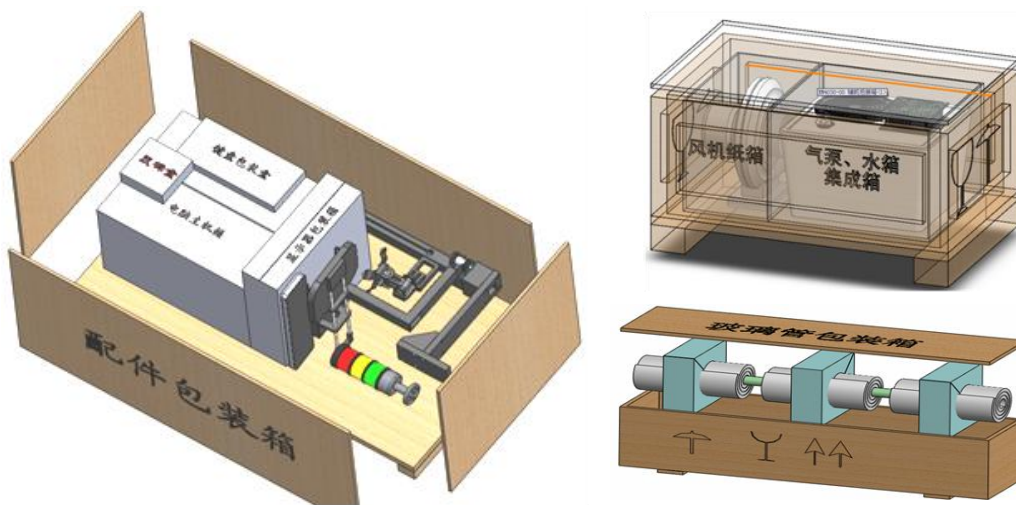



Fig.3-4 Auxiliary machine box and packing box of laser

3.1.2 Unpacking check

Check on the machine and auxiliary parts after unpacking is required to ensure them free of failure caused during transportation. Items to check are as below:

1. Check on machine model
Please make sure that machine model is just what purchase.
2. Check in machine appearance
Please make sure that the machine is free of scratch, damage, distortion and corrosion by appearance.
3. Check on machine case
Remove the upper, left and right cover to make sure that the machine is free of parts or cable caused by poor contact or internal damage.
4. Check on machine parts and auxiliary parts
Open the auxiliary case and laser tube packing box to verify parts following the packing list and check if there is damaged accessory or accessory with distortion.

 Attention	<p>Unauthorized unpacking is prohibited.</p> <p>If unpacking by user is needed, prior consent from our after-sales personnel or salesman is required. Otherwise, our company shall not be liable for any accidents caused.</p>
--	--

 Attention	<p>In case of the problems above found after unpacking, please timely notify our after-sales personnel or salesman, or directly contact our company.</p> <p>Unauthorized disposal is prohibited.</p>
--	--

3.1.3 Preparations for machine installation

Preparations for installation are as below:

1. Installation site

There are requirements for site and working environment to the laser machine. Please make sure if the site satisfies the related requirements from our company as specified in Section 1.5;

2. Personnel

Our company requests that the personnel for installation are professional customer service personnel from our company. If installation by customer is needed, the installation personnel are required to have received all trainings held by our company and grasped the related key points relating to the installation of our laser machine.

3. Tools

The related tools for installation are attached to the machine. In addition, users should prepare some installation and testing tools if necessary, e.g. screwdriver, multimeter, etc.

4. Others

Water, electricity, exhaust air channels, sample material, computer and power socket relating to the machine should be prepared ready in advance by users.

 Attention	<p>During installation by our customer service personnel, the customer is required to participate from the beginning to the end. Machine installation and debugging are parts of training, and the customers are required to learn them well.</p>
--	---

3.1.4 Steps of installation

3.1.4.1 The plank of display, keyboard and mouse installation

- The sketch map of display, keyboard and mouse plank as the following figure:

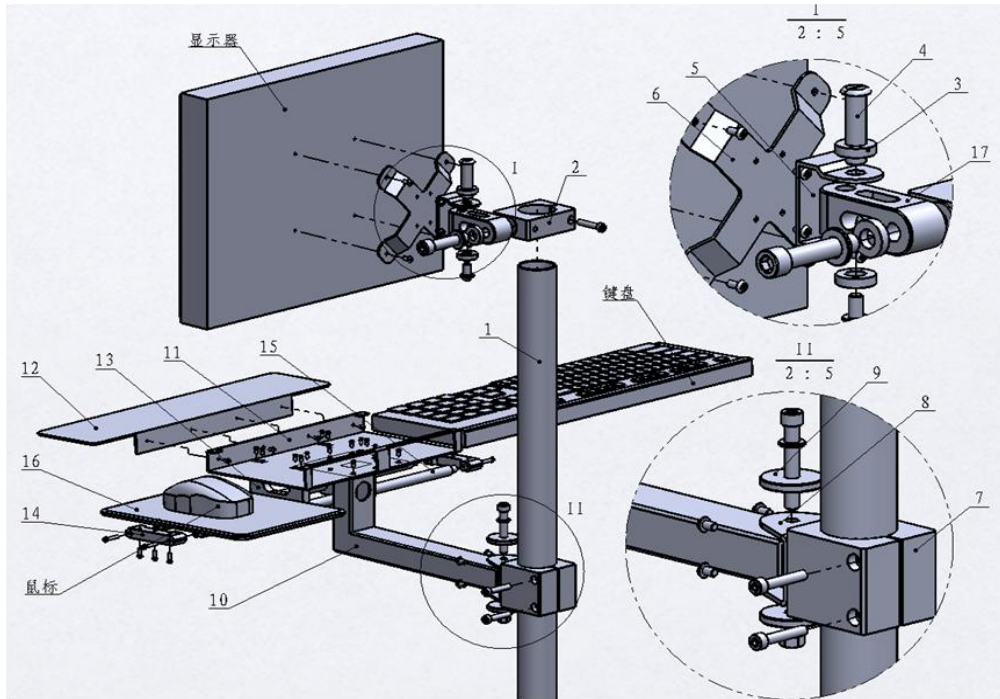

- 1 support, 2 rotating part, 3 adjustment ringer I, 4 pin axis, 5 connection part, 6 display stand, 7 lift base of keyboard, 8 hinge support, 9 adjustment ringer II, 10 keyboard support, 11 keyboard location, 12 support pad, 13 slide bar supported part, 14 slide bar connected part, 15 slide bar, 16 mouse supporting board 17 rocker

Fig.3-5 The sketch map of display, keyboard and mouse plank

- The installed complete plank as follow:

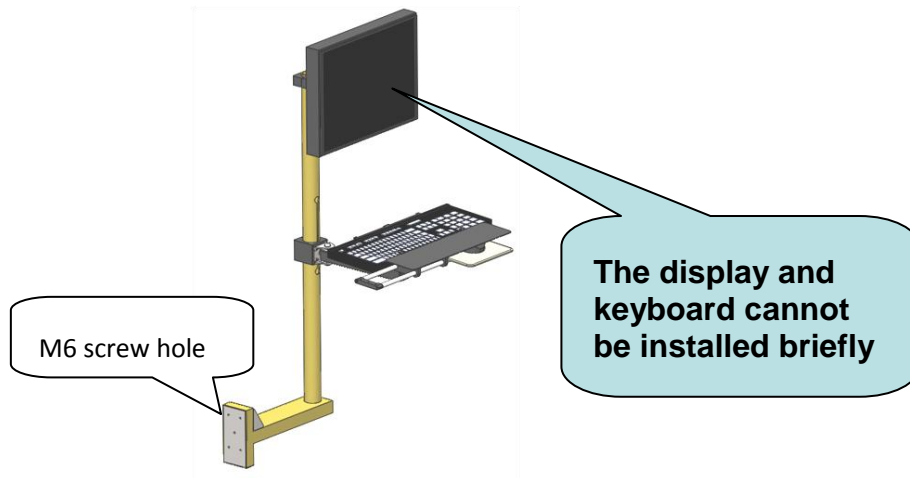

Fig.3-6 The plank of display, keyboard and mouse

- Open the front cover and right cover of machine, find the four screw hole of the plank of display, keyboard and mouse, use M6 screw to screw down:

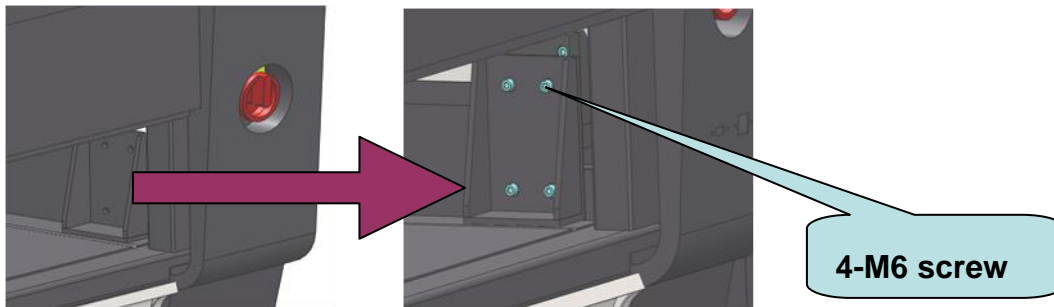

Fig.3-7

- Put the keyboard and mouse in proper position and refer to Fig.3-8 for the wire path

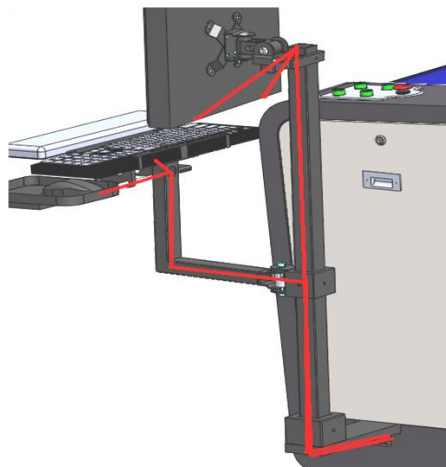

Fig.3-8 The line sketch map of display, keyboard and mouse (red is the connection)

3.1.4.2 Host computer installation

- Take out the host computer from the auxiliary machine box (Figure 3-4), put it to the bottom of host computer box as the following figure:

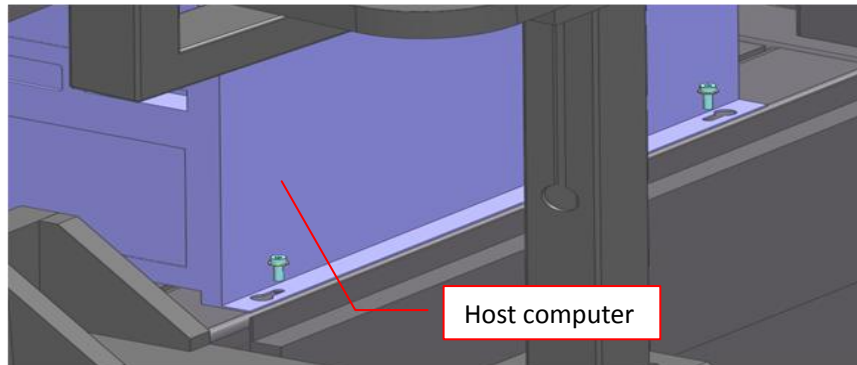

Fig.3-9 Host computer installation

- Link the lines of host computer, display, keyboard, mouse, controller and graph collected card, and insert softdog.

3.1.4.3 Three-color indicator light installation

- Take out the three-color indicator light from the packing box (figure 3-4), matching the four orientation hole at the top right surface of the machine as the following figure:

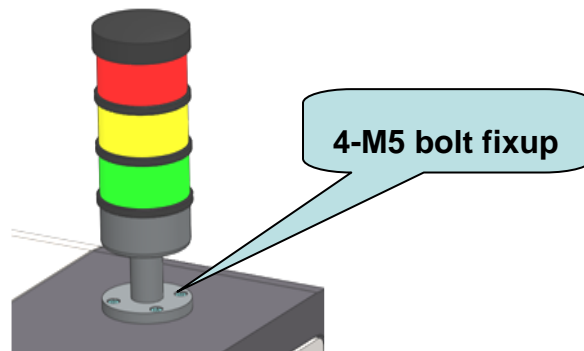

Fig.3-10 Three-color indicator light installation

- Put through the connection head of three-color indicator light and the relative connection head of inner machine.

3.1.4.4 Laser tube installation

- The laser tube is mounted on the back of the machine. After removing the protective cover of the laser tube, you will find two laser tube brackets, As shown in the figure below:

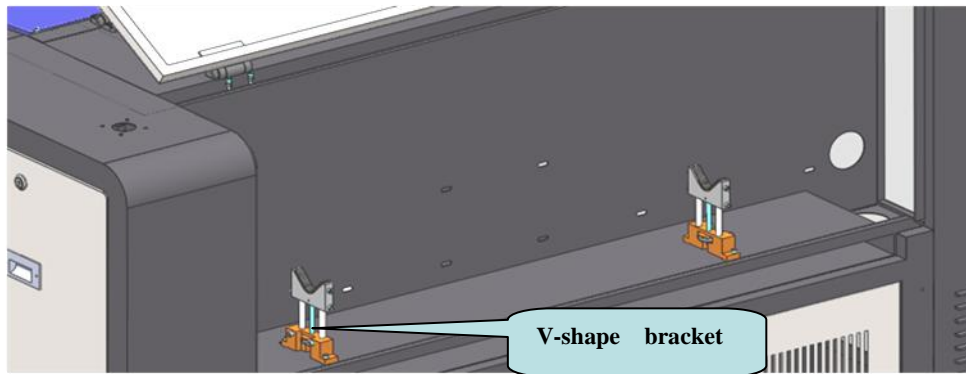

Fig.3-11 Laser tube plank

- Firstly open the two brackets and carefully insert light outlet (negative end) of the laser tube toward reflector No. 1 into the V-shape bracket as shown in the figure below:

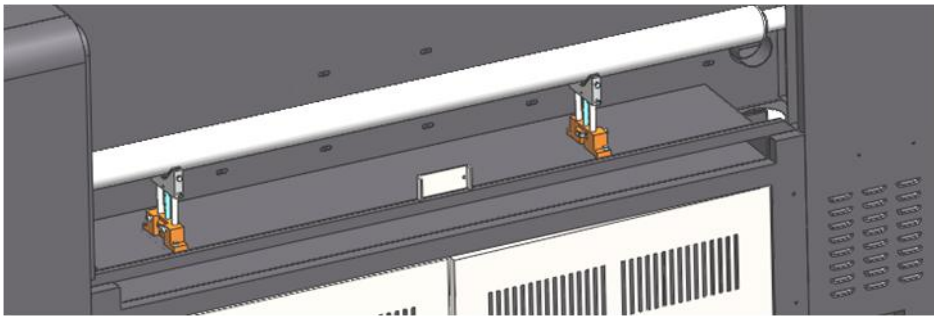

Fig.3-12 Placed laser tube

- Adjust the fore-and-aft distance of laser tube (above 50mm away from reflector1), then, buckle the belt on the laser tube bracket and screw down to fix securely the laser tube as shown in the figure below:

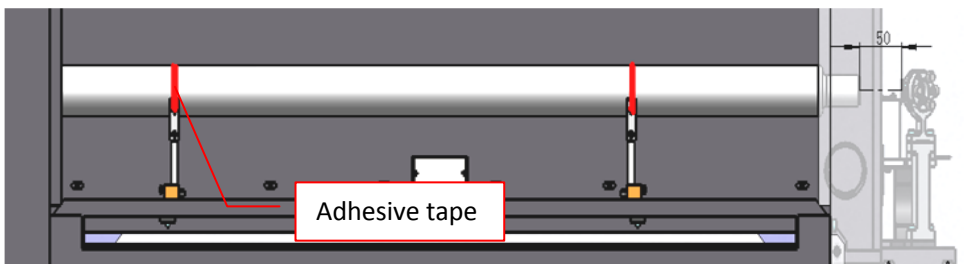



Fig.3-13 Rivet laser tube

 Attention	<ul style="list-style-type: none"> ● Fix the laser tube with proper force to avoid damage against it. ● It is a must to keep the water inlet (light outlet end) at lower part of the tube.
--	--

- After fixation of the laser tube, connect the water inlet end with water protection to water inlet at negative end of the laser tube, and connect another water inlet hose reliably to water outlet with high pressure as shown in the figure below:

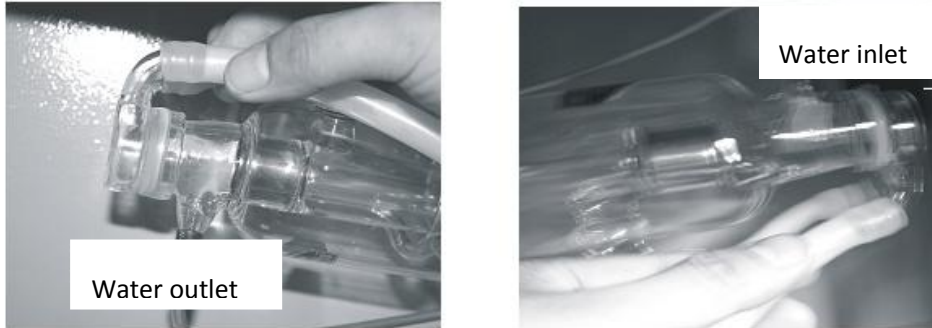



Fig.3-14

 Attention	<ul style="list-style-type: none"> ● Reliable connection of each water hose is required to avoid leakage; ● Keep water hose in good order free of twist for smooth water flow.
--	--

- Finally, pass the laser tube power cord through the hole in the case and pull it towards the laser power supply as shown in the figure below:



Fig.3-15

3.1.4.5 Laser power supply installation

The appearance of laser power supply is as shown in the figure below:

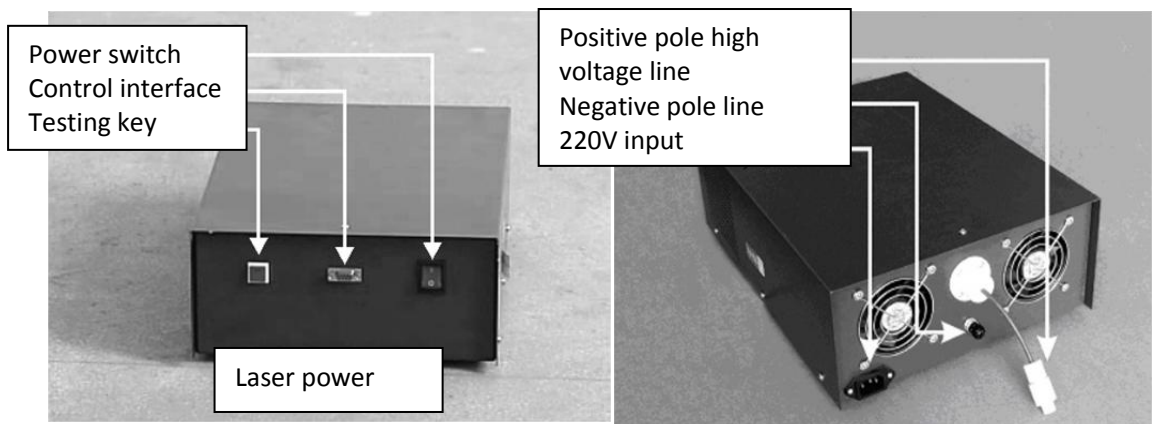

Fig.3-16 Laser power supply

- Put the laser power supply into the box (laser power supply box) at the back of the case. Firstly connect the positive pole line, unfasten white plastic screw cover of the laser tube positive pole line as shown in the figure below:



Fig.3-17

- Align the copper hole with positive copper post of the laser power supply, and then slowly screw down the white plastic screw cover as shown in the figure below:

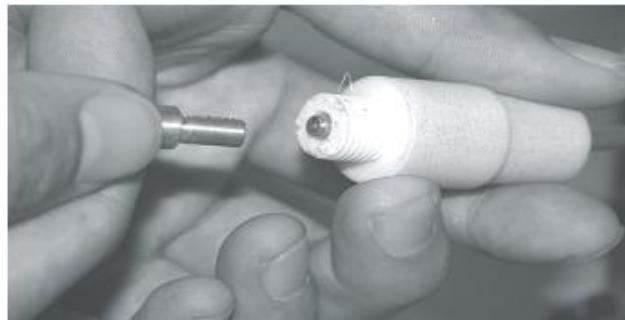

Fig.3-18

- And then securely connect the negative pole line to the negative pole end of the laser power supply and fix positive pole high voltage connector on to the insulation bracket as shown in the figure below:

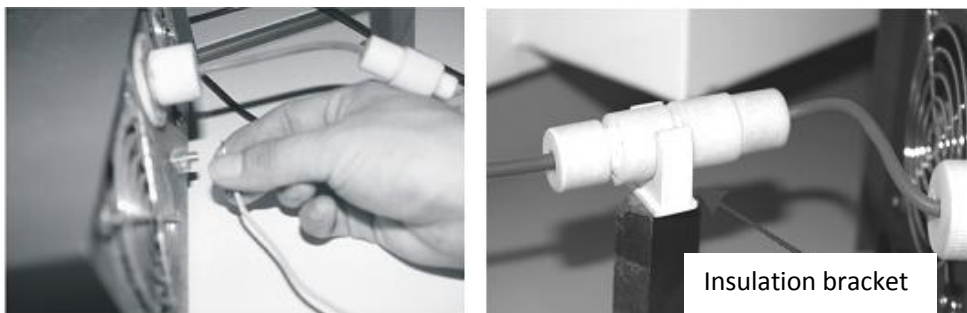



Fig.3-19

- Finally open the side door of the carving machine to pass the control line through the small hole in the working table, connect it to control interface of the laser power supply and securely fix it. Installation of laser power supply is then completed as shown in the figure below:



Fig.3-20

 Attention	<p>Red positive pole line and yellow-and-green negative pole line are a pair of high voltage line of the laser tube, and they with extremely high voltage (20,000V) and super strong static radiation. Reliable line insulation and isolation, as well as secure earthing of the machine, are required. Otherwise, sparkle and serious interference may possibly caused and influencing on the operation of the machine. Serious current leakage is dangerous to human body.</p>
---	--

 Attention	<p>During operation of the machine and after power-off, please do not touch the high voltage line with hand. Otherwise, electric shock or even death may be caused.</p>
---	---



3.1.4.6 Water cooling system installation

- Fill up water tank (or industrial water chiller) with purified water;
- Securely connect water pump and water outlet connector, insert water hose, and place it into the water tank;
- Pass the water hose connecting to the water pump through the small hole in the water tank cover and connect it to water inlet of the machine, and then connect another water hose to water outlet of the machine and place it into the water tank to complete water circulation piping connection as shown in the figure below:



Fig.3-21

- Connect through power supply. At this time, you will find that water is gradually filled up the laser tube, smooth water flow in the water outlet indicates normal operation of the water pump.

 Attention	<p>To ensure normal circulation of cooling water in the laser tube, the water circulation system is equipped with a water protective inducer. In case of unsmooth water flow or abnormal operation of the water pump, the machine will automatically enter protective mode, and the laser tube will emit laser. Therefore, during daily maintenance, please keep the water pump and water hose clean.</p>
 Attention	<p>Water cooling laser tube is required to ensure a normal operation of water circulation. Otherwise, laser tube explosion may be caused.</p>

3.1.4.7 Air pump installation

- Connect air outlet of the air pump (or air compressor) to air inlet of the machine with an air pipe, and connect through the power supply as shown in the figure below:

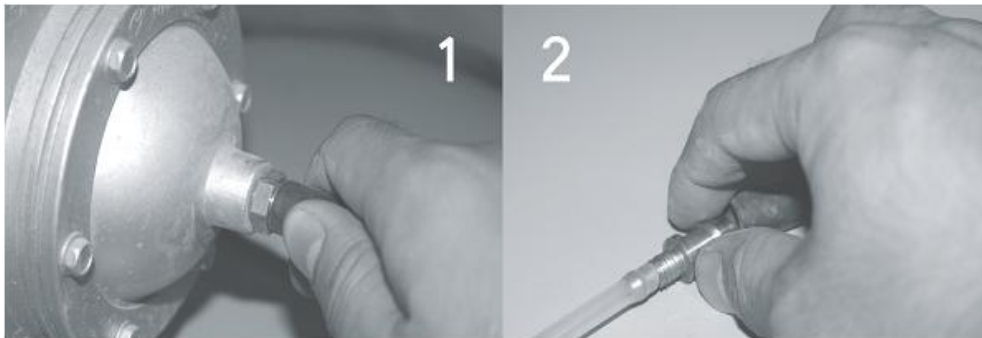

Fig.3-22

The air pump (or air compressor) is very important in the system. High pressure air is jetted out from light outlet in the laser head through air pipe. On one hand, this ensures focus lens clean. On the other hand, it plays the function to prevent from being burning of the material caused by laser. Therefore, during daily maintenance, users are recommended to keep the air pipe straight free of twist. Otherwise, abnormal blowing may cause burning of the materials.

3.1.4.8 Blower installation

- Firstly connect air inlet of the blower to dust inlet of the carving machine with an air pipe, and securely buckle it. Then, connect another air pipe with air outlet of the blower and stretch it outside the room, and finally reliably connect the power cord of the blower as shown in the figure below:



Fig.3-23

3.1.4.9 Machine earthing

Safe earthing is strictly required for power supply system of SM960 series laser machine. Power supply of users must satisfy safety regulations of the local government:

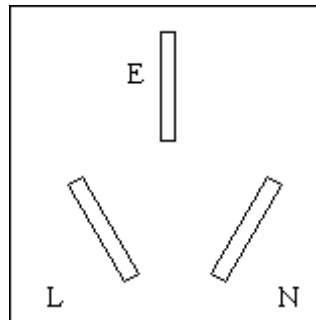



Fig.3-24

- L: Live line of 220V AC system. Safety electric switch is required for this line (The switch is required to be mounted on the live line.)
- N: It is popularly named as null line with the function of completing power supply together with the live line.
- E: Earthing line. All casings (earthing end) of electric parts are connected to this line to ensure safety. Earthing resistance should be less than 5Ω.

Users are required to consult professional electric equipment installer (electrician), and have the professional electric equipment installer check and determine if the earthing is reliable.

 Attention	<p>Poor earthing may cause high rate of failure to the machine. In addition, safety accident may also be caused. Our company shall not be liable for the accidents and failure caused it.</p>
---	---

If your power supply system is not with an earthing, it is a must for you to have professional electric equipment installer mount a safety earthing net in the following method:

- It is a must to use 2-4 pieces of 4×35×1500mm angle iron hammered into any wet place surrounding the house as earthing. Distance between each two angle iron is 1m. And then use a 3×30mm flat plate leads each angle iron out from earth surface to form a good earthing net.

- After completing the earthing net, measure earthing resistance with an apparatus, the standard value is 3-5 ohm.
- After measuring the resistance, connect one end of the RVV2.5mm² copper core cable to the eduction of the earthing net, one end is connected to the earthing of the carving machine and earthing hole of the socket as shown in the figure below:

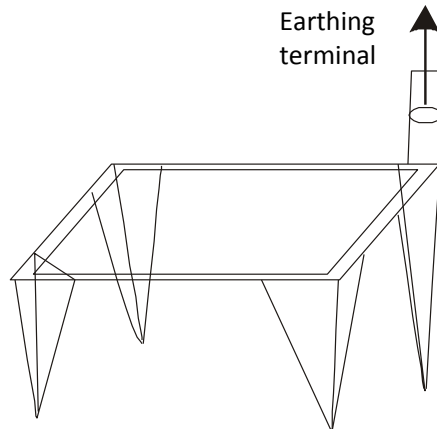

Fig.3-25

3.1.4.10 Removal of fixation block

At-ex-factory, to avoid unexpected impact during transportation, the machine is equipped with fixation block on XY movement mechanism. During installation, they should be removed. Removal of the fixation block is as shown in the figure below:

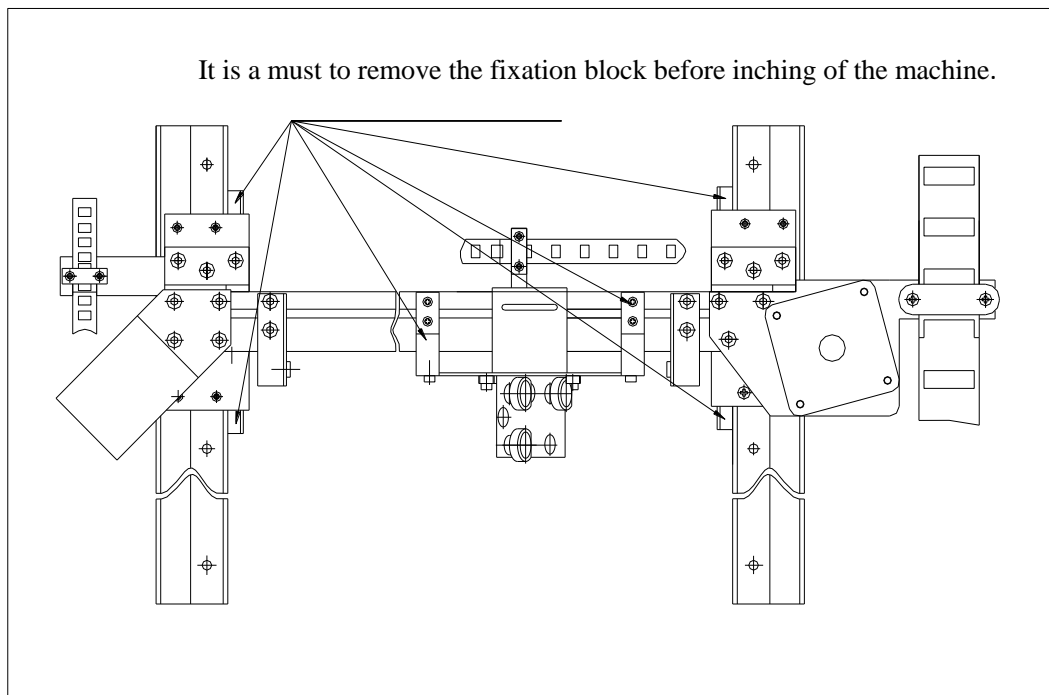

Fig.3-26

3.1.4.11 Cutting head installation

At ex-factory, to ensure safety and prevent the laser head from being polluted during transportation, the cutting head (focus canister) of some types of machine are individually packaged and kept. During installation of the machine, they should be replaced back.

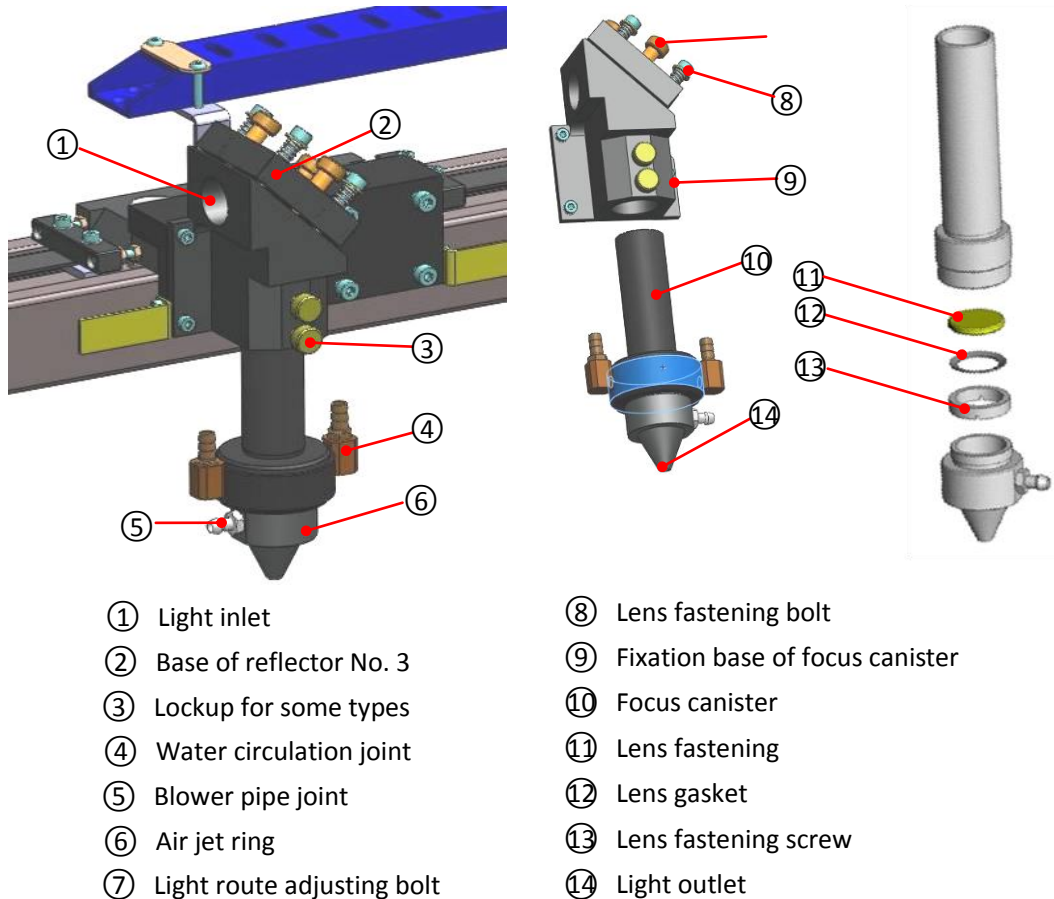

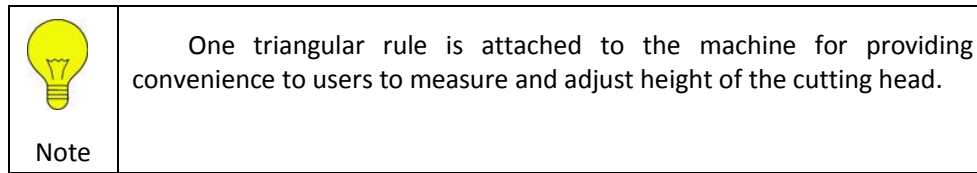

Fig.3-27 Cutting head configure

- Firstly install the focus canister. Unfasten the lockup bolt of the focus canister as shown in the figure above, insert the focus canister into the base, adjust to a proper height (depend on the focus), and then it will be OK to screw down the bolt.
- And then connect the air pipe. Focus equipped on some types of machine with larger power is with water circulation cooling joint, and it should also be connected.
- If height of the cutting head is needed to adjust in the future, it is only to unfasten the lockup bolt of the focus canister for manually adjusting the height.

 Attention	<p>Do not adjust height of the cutting head during processing (during light emitting) to avoid burn to human body.</p> <p>The height from the cutting head to surface of work piece is a fixed value. The value differs due to different focuses configured.</p>
---	--



Module configuration of cutting head and visual head as the following figure:

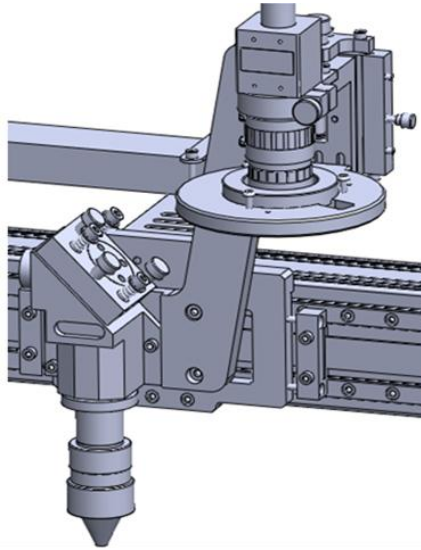
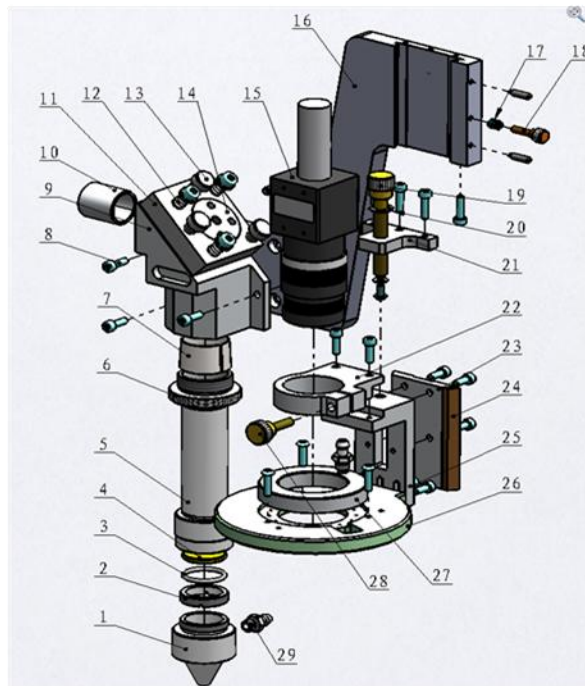

Fig.3-28 The module of cutting head visual head

The analytical figure as follow:



1-Jet cup, 2-Pressed lens nut, 3-Fluorine rubber (type O sealing ring), 4-Focus lens, 5-Focus tube, 6-The jet cup telescopic locked nut, 7-tensioner, 8-Inside hexagonal cylindrical head screws, 9-Cutting head support, 10-Lights part, 11-Microscope support, 12-Lens adjusting spring, 13-Adjustment screws, 14-Pressed lens nut, 15-Industrial camera, 16-Camera retaining plate, 17-Compact spring, 18-Gib locked screw, 19-Lens lift bolt, 20-Elastic retainer ring of axis, 21-The retaining plate of camera lift, 22-Camera clamping board, 23-The connection board of camera lift, 24-Gib, 25-The installed support of camera, 26-Lamp tray, 27-Lens edge device, 28-Lens locked bolt, 29-Tracheal interface

Fig.3-29 The analytical figure of cutting head and visual head

3.1.4.12 Software and machine drive installation

SM960 series machine collocated computer which has installed the operation system (Windows XP) and driver. If users want to install again, please conform to the following principles:

- The machine has installed and debugged the operation system, software and driver when producing. Unless necessity, please do not install again;
- The machine has mirrored the system at ex-factory; it can be restored by one key. If you want to install the system again, you can try to the restored it by one key.
- The machine has backup the correlative parameters of software when producing, including system parameter (config.xml), emendation file(*.cal), test template file (*.mdl), testing graph (*.smc) and correlative software installation bag, including SmartCarve4 installation bag, driver installation bag of graph collected card, installation file of movement controller driver, etc. please do not delete.

- Please refer to *User Manual of Machine Vision System* about the software and driver installed.

 Attention	<p>Please properly keep the CD and software encoder encryption dog attached. In case of missing, please cont our company for purchasing.</p> <p>Reinstallation of the software may cause parameter loss of the system. Please perform backup of the related parameters before reinstalling the software or system.</p>
--	--

 Attention	<p>Please protect the using environment of machine, please do not insert U-disk at will, and avoid poisoning. For the common hardware and software trouble of computer, users should know the disposal ability.</p> <p>Users can not use the computer to install other software and take the computer to other purpose; we won't take the responsibility for these aftereffects which causing by them.</p>
--	--

3.1.4.13 Other auxiliary part installation

Some types of machine are attached with other auxiliary parts (e.g. foot switch) as per request from customers, and these parts should be installed by our customer service personnel. Moreover, users shall install scanner, printer and other machine prepared by themselves.

3.2 Instructions of machine button and indicator light

3.2.1 Power switch

Power switch is at the right bottom of the machine, it is a red knob switch as follow:

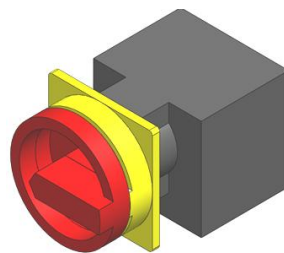

Fig.3-30 Power switch

Power switch control the working power supply of machine and the fan of electric control box. When turn it on, the head lamp of machine inner will be light automatically.

3.2.2 Emergent stop button

The machine equipped stop electrocircuit, emergent stop button is at the two sides' cover of the machine. Press any stop button to stopping when the emergency appears. All the dynamic power supply of machine will be switched off after you press the stop button, the machine stay at "stop" status.

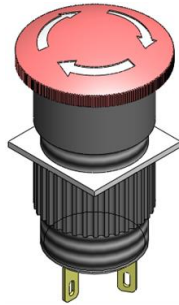



Fig.3-31 Emergent stop button

 Attention	<ul style="list-style-type: none"> ● After press the stop button, the system will switch off all the dynamic power supply (e.g. machine power supply and laser power supply), controlled power supply is still electrifying. Necessarily, if you want to switch off the power supply of the whole machine, you should turn off the switch of total power supply even pull out the electric cable of total power supply. ● You can loosen the stop button and continue to operating only when the emergency has been removed and all the flaws have been rectified or the breakdown has been restored.
---	---

 Note	<ul style="list-style-type: none"> ● After get rid of the emergency, reset the stop button by rotating clockwise to relieve stop. ● You should restart the software to restore the machine to work after relieve stop.
--	--

3.2.3 Power supply control panel

Power supply control panel is used to control the power on and power off of machine, including emergent stop button, power on button, power off button, PC power on switch (key switch), and laser on button. Some indicator lights are put in the buttons to denote the power on status of current machine.

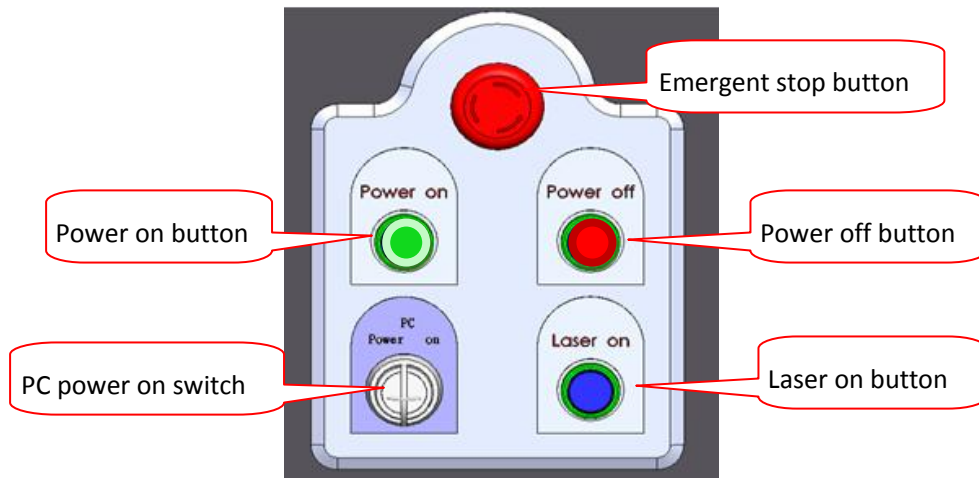

Fig.3-32 Power supply control panel

Instructions of button functions as follow:

- Power On: power on button, used to power on the machine, the green indicator light will lighting after electrifying normally;
- Power Off: power off button, used to power off the machine;
- Laser On: laser on button, used to control the power on and power off of laser power supply, the red indicator light will lighting after electrifying normally;
- PC Power On: it is a key switch, used to startup and close the power supply of host computer;

The indicator light of button can denote the power on status of current system as follow:



Fig.3-33 The indicator light of button

- Green indicator light: it means the main loop system and control system of machine normal working have powered on when it lighting (green light);
- Red indicator light: the indication laser power supply, the laser module has powered on when the indicator light lighting (red light).

 Attention	<p>Indicator light only denotes the power on status of the controlled parts, not mean whether the machine power off absolutely.</p> <p>Please look-over whether the indicator light all right or not, and dispose it in time.</p>
---	---

PC power is a key switch as the following figure:

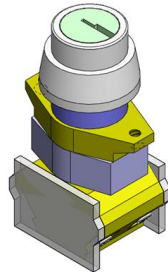

Fig.3-34 PC power



Note

The owner of machine must keep appropriately and using reasonably for the key of key switch, operator should take the warrant from the owner if you want to gain the key and operate the machine.

3.2.4 Three-color indicator light

The three-color indicator light indicate the current status, match with the four fixing holes in the upper right surface of the machine.



Fig.3-35 Three-color indicator light

Indicator offer information by light and voice, some status as follow:

- Green light often lighting: stand-by status, the machine status is normal;
- Red light lighting: lighting status, remind user that the laser is coming out at the moment;
- Red light often lighting with the buzzer ringing: the machine trouble give an alarm;
- Green light and red light lighting at the same time: working at the moment;
- Yellow light often lighting: working pulse;
- Green light often lighting with the buzzer ringing three times: process finished.

3.3 Machine debugging

After completing installation, machine debugging and processing test are needed. The machine debugging is mainly to complete status test of each module of the machine including movement module, laser module and electric IO module.

3.3.1 Sequence of power-on and power-off

There is an instruction of sequence of power-on and power-off stuck on the master power switch.

- Sequence of power-in:

Master power supply of the machine → Water chilling system → Laser power supply → Computer → Other auxiliary parts

- Power-off is in the reverse sequence as:

Other auxiliary parts → Computer → Laser power supply → Water chilling system → Master power supply of the machine

- Insert the power supply (behind the machine) into the electrical outlet, electrify the electrical outlet, then rotate the total power supply switch by 90° clockwise to power on the machine as follow:

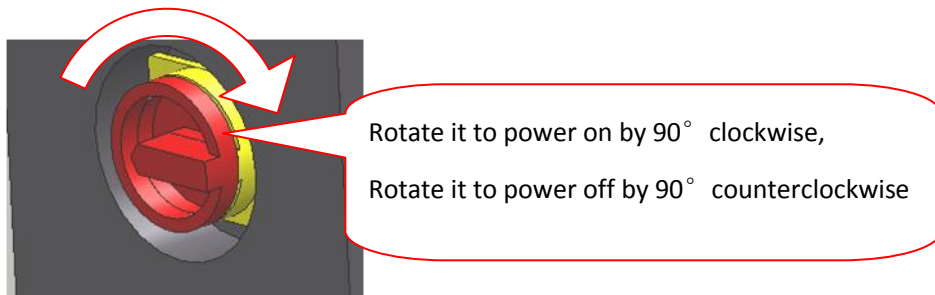



Fig.3-36 Total power supply switch

- After the total power supply of machine power on, the daylight lamp in the machine inner will lighting automatically. At this moment, through the green button (power on) of the power supply control panel to power on. If the machine power on normally, the green light in the button lighting. If the green light not lighting, the machine power on by trouble, please look-over whether the stop switch loosen or not.
- Then put the key to key switch and rotate it clockwise to start computer;
- Cooling system supply power independently, insert the power line of water chiller into electrical outlet and electrify it;
- After the cooling system working normally, press the red laser power supply switch of the power supply control panel to power it on. The red indicator light will lighting if it is normal; or the laser power supply trouble when power on, you should look-over it (e.g. whether the cooling system works normal or not).
- Finally, switch on the power supply of auxiliary machine, e.g. air blower.

For the above steps, the start operations of whole machine have finished, the close operation is opposite with the start operation.

 Attention	<p>Users should operate following the requirements as per power-on and power-off sequence. Otherwise, failure may be caused to the machine.</p>
--	---

 Attention	<p>If you want to close the computer, please close the system first (close it in the operation system). Then rotate the key counterclockwise, and power off the computer.</p> <p>Please wait 15 seconds after you power off the computer if want to start it again.</p>
--	---

3.3.2 Movement debugging

Movement debugging is mainly to check if movement status of each movement shaft is normal. At ex-factory, movement debugging has been performed. In case of no accident occurred during transportation and installation, there will be no any problems with the machine. The followings are instructions for motor shaft movement, resolution setting, strike and limit configuration, test on straightness and perpendicularity.

3.3.2.1 Motor shaft movement

After normal power-on of the machine, start the computer, run the SmartCarve4. If the software has set the auto home, it will start auto home. When the machine stand-by, press the four direction keys of the control panel can control the cutting head to process. If the four direction move normally, the electrical machinery of X axis and Y axis move normally. Moreover, SM960F also have Z axis and A axis, used to control the feeding module. If the electrical machinery axis in trouble, please contact the customer service personnel from our company to solve it.

The following figure is the sketch map of software control panel of No.4 controller:

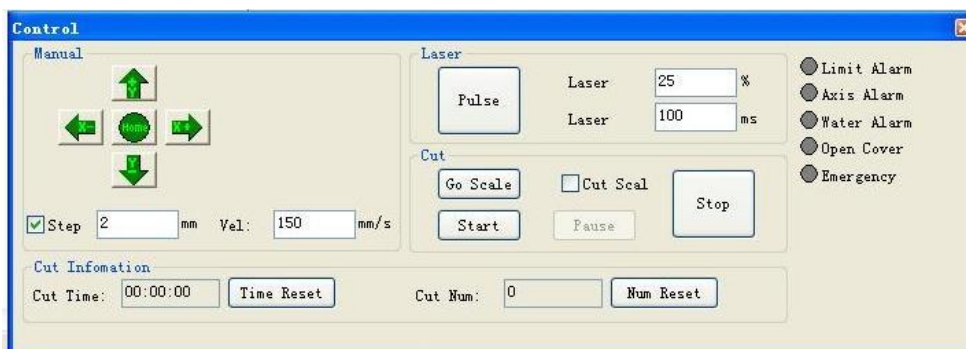
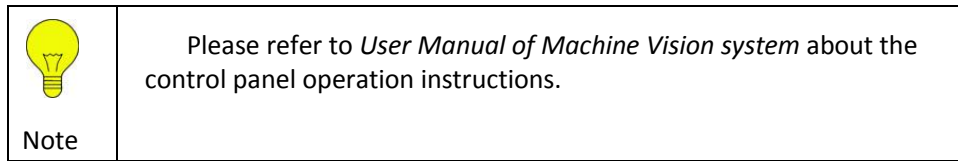

Fig.3-37 Control panel



3.3.2.2 Pulse equivalent

Pulse equivalent determines the precision of motion and whether the actual position of the motion is correct.

Pulse equivalent is in the motion parameter of machine parameter, the unit is pulse/mm, it means the pulse number set out by system when then motion axis progress 1mm.

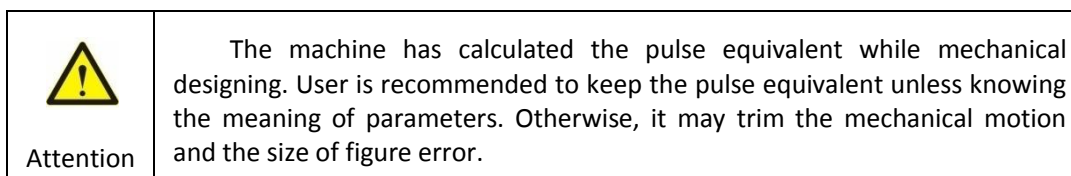

The following figure is the motion parameter setting interface of No.4 controller.

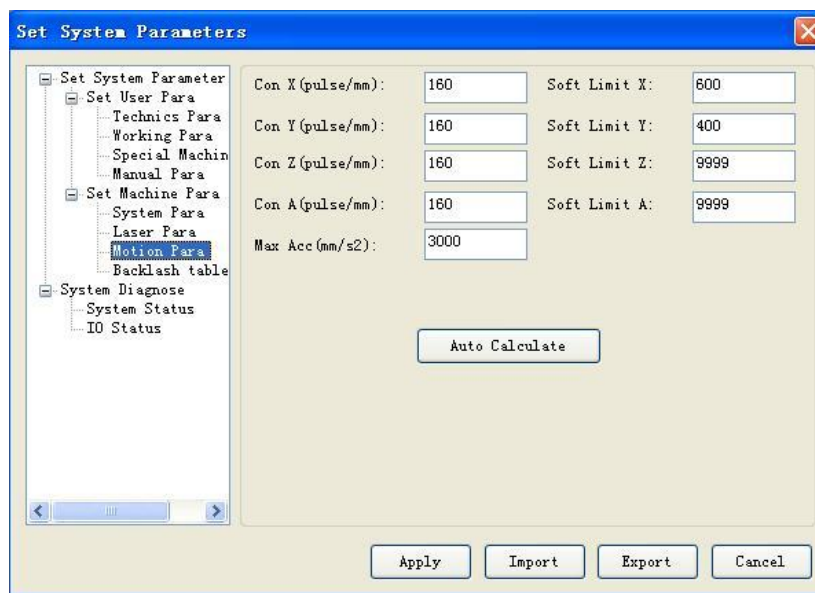



Fig.3-38 Setting interface of movement parameters for No.4 controller

While mechanical motion and the size of figure error, it need to modify the number of pulse equivalent. The software offer auto calculate tool, for more details please refer to *machine vision system owners' manual*. The method to test whether the motion equivalent of every axis right or not: control the machine to go scale (a rectangle with 100mm*100mm), measure whether the distance of every side is 100mm or not, the pulse equivalent setting is error if it exist error.

You should restart the software after modify the machine parameter.

 Note	SmartCarve4 can control many controller and machine from our company, users need to set the controller type when install first time. Otherwise, the parameter setting and data will be error.
---	---

3.3.2.3 Stroke, limit and reset

Different models of machine are with different working breadth, and setting stroke of each shaft of the machine will play the function of breadth protection (equals to software limit). Stroke parameter setting is shown in figure 3-38 for No.4 controller. Wrong stroke setting will possibly cause fail to have a full breadth work or “overreaching” of the laser head. Taking SM960 type of machine as an example: theoretically the effective processing breadth of the machine is 900mm X 600mm. Then, strike of X-axis should be set to 900, and Y-axis to 600.

 Attention	Due to the less difference caused during production and assembly of the machine, the actual strike of each shaft on the same type of machine may be with a small difference. Stroke setting is subject to the actual stroke.
--	--

Limit switch is the hardware sensor equipped on limit position of the two ends of each shaft. After detecting limit triggering signal, the movement shaft will perform emergency stop to avoid “overreaching”. Minimum one limit switch is needed for each shaft to indicate limit position of the current shaft. In figure 1-6, you can find the installation position of the limit sensor. The installation position of limit switch may differ due to different types of machine, so the triggering signal. Therefore, configuration is needed.

Zero point of the machine is a referential point of a certain hardware fixed in processing breadth. Generally, after power-on, “reset” is needed for the machine to create coordinate of lathe. SM960 series machines from our company generally take the limit switch position of each movement shaft as the zero point of the machine.

 Attention	At ex-factory, configuration of parameters for stroke, limit and reset has been already performed. Unauthorized change of parameters by user before making clear its meaning is prohibited. Otherwise, failure of the machine may possibly be caused.
--	---

3.3.2.4 Straightness and perpendicularity

Before starting formal processing, testing of movement straightness of each movement shaft and perpendicularity of X-axis and Y-axis are needed. The straightness ensures movement accuracy and stability of movement for this shaft. The testing shaft can be controlled to move along a straight line. If the straight line is measure unstraight, it means twittering exists during movement of the shaft, and a solution is required. Reasons for straightness of single shaft frequently lie in transmission of the motor or mechanical movement and machine vibration.

Movement coordinate system of SM960 series machine is a rectangular Cartesian coordinate system. Theoretically, X-axis and Y-axis should ensure be in absolute uprightness to

ensure processing accuracy. If case of large tolerance for the straightness, distortion of the processed figure will be caused. Method of measuring the straightness is to have the control machine go a rectangle frame on the surface of processing, and measure if the length of four sides and diagonal are the same. Method of adjusting perpendicularity is to make adjustment of assembly of X-axis and Y-axis movement mechanism.

 Attention	Debugging of straightness of perpendicularity of each shaft has been already performed at ex-factory of the machine. In case of problems found by users, please timely contact our customer service personnel for a solution. Unauthorized disassembly of the machine is prohibited.
--	--

 Note	When debug the motion axis by SmartCarve4, you can switch the machine type to No.4 controller, it can control the machine to processing independently with this controller without vision system.
---	---

3.3.3 Laser debugging

Laser debugging contains two aspects: light emitting test and light route adjustment. The followings are the details for them:

3.3.3.1 Light emitting test

After normal start up in case of power-on, with “laser switch” button on the control panel of the machine, you can test if laser emitting is normal. Light emitting energy and spot spray time can be directly set on the panel to check if laser spot spray power is normal. If there is no laser emitting from the spot spray laser tube, it means that there is problems with the laser emitting, and check is required. In case of laser emitting found from the laser tube, but no laser emitting from the cutting head, it means improper position of the light route, and adjustment of light route is needed.

When no laser emitting from the spot spray, firstly make check on setting of the related parameters of the laser device. The followings are interfaces for setting parameters of No.4 controller.

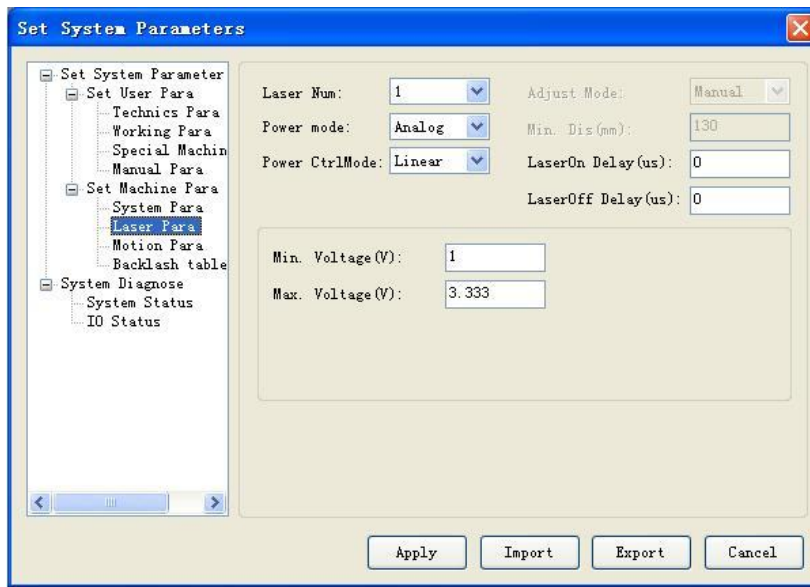



Fig.3-39 Interface of setting laser parameters for No.4 controller

Refer to the operation manual for the machine vision system for more details about laser parameters. Wrong laser parameter setting may possibly cause abnormal light emitting or fail of adjusting laser power. In case of no light emitting under the condition of making sure that laser parameters are set to correct values, check on hardware is needed. You may use red “test” button on the back of laser power supply from our company to check if laser power supply and laser tube are normal as shown in figure 3-16.

In case of no laser emitting, plug out the controller control cable from the laser power supply, open the laser power supply, and press the light emitting button. If there is laser output from the glass tube at this time, it means that laser power supply and laser tube are normal in working. At this time, check on the controller and laser control line is needed. In case of no light emitting, further check on the laser power supply of the laser tube is needed.

 Note	The control panel of some types of machine is equipped with ammeter. With the ammeter, you can check if the power is normal. Theoretically, the maximum power of 80W laser tube is corresponding to the current roughly 25mA, and the 130W laser tube to 30mA of the current.
---	---

3.3.3.2 Light route adjustment

Due to vibration during transportation, aberrancy of light route may possibly be caused. At this time, light route correction is needed.

Light route of SM960 series laser machine is as shown in the figure below:

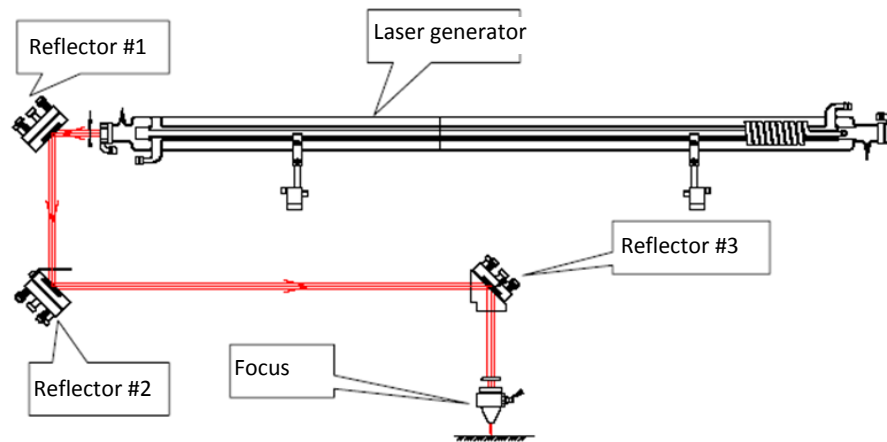

Fig.3-40 Illustration of laser route

After being emitted from the laser generator, laser successively passes through reflector #1, #2 and #3, and finally emitted to working table after be focused by the focus. Transmission of the laser is actually a course of multiple reflection and focusing. During this course, in case of loosen reflector, laser route deviation will be caused make the laser fail in finally output through the jet cup.

The adjustment steps follow:

- Firstly adjust reflector #1. Move crossbeam to the closest point to lens #1, and then move to the furthest point. By adjust the three screws at the back of the lens to adjust angle of the lens to have this light spot overlap on the first light spot.

Adjusting bolt of reflector

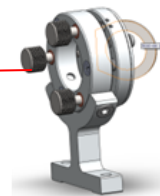

Fig.3-41 Reflector base

- Then, adjust reflector #2, in the same way to move the laser head to the closest point to lens #2 and make a light spot, and then move the furthest point and to the furthest spot overlap on the first light spot.



Attention

The positions of the light spots above are recommended to emit at the center of lens, but not the edge. In case of being at the edge, further adjustment is needed till being at the center.

- Finally check if the light spots are overlapped if the laser heads are located at different peaks. In case of fail of overlap, please make further adjustment in the way above till achieved.

- After adjusting four spots overlapped, let's check if this point is emitted at center of light inlet of the laser head. If no, please power off the laser; adjust position of the laser tube. In case of deviation leftward or rightward, adjust to this direction if deviation towards it. For example, in case of leftwards deviation, adjust the laser tube to the left side; in case of rightward deviation, and then move the laser head to the right side. In case of up or down deviation, adjust to the opposite direction, meaning that in case of up deviation, adjust the laser tube downward;; in case of down deviation, then to adjust upward.) The adjustment above is only for negative pole end of the laser tube (light outlet end). In case that positive pole end of the laser tube needed to achieve the same effect, the direction is the opposite.)

 Attention	<p>Laser is invisible light and with direct harm to human body. While adjusting the light route, the operator is required to pay great care. The operator is not permitted to make adjustment until having received professional training.</p> <p>During adjustment, pay attention to the lens to have them free of pollution by smoke and dust.</p>
--	--

3.3.4 Machine vision debugging

Machine vision module is used to control auto visual orientation of machine. The working state of vision module determined whether the orientation of visual cutting machine right or not and can look-over the object or not. Vision debugging is mainly including camera parameter, camera calibration and orientation test. For more detail, please refer to *User Manual of Machine Vision System*.

 Attention	<p>The machine has debugged the vision system when producing, including camera parameter, camera calibration and look-over parameter. Please read <i>User Manual of Machine Vision System</i> carefully before using. Please do not modify unless you know the meaning and direction of the module and parameters, otherwise, the machine may working error.</p>
--	---

3.3.5 Trial operation of processing

After completing debugging of the movement and laser module with the steps above, you can start figure trail processing now.

- Firstly start up the machine according to the sequence of power-in, start up the auxiliary machine like air pump and blower;
- And then prepare ready the materials to be processed, and place the materials horizontally on to the surface of working table;
- Open upper computer software (SmartCarve4), make figure (or figure data lead-in) and set ready the processing parameters and processing path;
- Draw and insert the process path of template graph, save and hold the SMC file.

- Set the process parameter (layer parameter), and technics dispose of correlative data (optimize path).
- Adjust distance of the laser head to make laser focus located on surface the materials to be processed;
- Move the laser head to the start point of processing (set positioning point);
- Start processing.

The above are the basic processing steps. Refer to machine vision system operation manual and operation instructions of the related computer software for detailed processing operation.

Chapter 4 System Maintenance

Stable and normal operation of the machine is closely related to daily correct operation and maintenance. This chapter mainly introduces the way of daily maintenance.

4.1 Mechanical maintenance

Mechanical maintenance mainly includes the maintenance of: guide rail, linear shaft, slide block assembly (metal guide pulley), nylon guide pulley, synchronous belt, synchronous belt wheel, screw and coupling. It is a must to the followings well done for maintenance:

- After completing use every day, cleaning all parts of the machine and oiling sliding mechanism like guide rail with lubricant are required.
- Make irregular check on the machine to mainly check if there is poor contact of the joints. In case of abnormality, timely treatment is needed to avoid causing serious problems.

The followings are detailed information concerning maintenance of each mechanical part.

4.1.1 Guide rail, linear shaft, slide block assembly (metal guide pulley), nylon guide pulley

Guide pulley and linear shaft are core parts of the machine. Their function is for direction leading and supporting. To ensure a higher processing accuracy of the machine, higher direction leading accuracy and stable movement of the guide pulley and linear shaft are required. During operation, plenty of corrosive powder and smoke are generated from the processed workplace. In case of long-term stay of the smoke and dust in the surface of the guide pulley and linear shaft, the accuracy of the machine will be greatly lowered, and corrosive points will be formed on the surface of the linear shaft causing lifespan of the machine shortened or may cause rust and burn. To keep normal operation of the machine and ensure processing quality, daily maintenance shall be well done.

- Cleaning and maintenance of the linear shaft:

Linear shaft on crossbeam: Disconnect the power supply of the machine, move the laser head to the rightmost (leftmost), repeatedly clean the linear shaft along with it with a piece of cotton cloth till the linear shaft free of dust; and then move the laser head to the leftmost (or rightmost), repeatedly clean the linear shaft along with it with a piece of cotton cloth till the linear shaft free of dust. Finally, apply proper amount lubricant (or sewing machine oil, but machine oil is prohibited) on to the linear shaft, slowly push the laser head along leftward and rightward repeatedly for couples of time to make the lubricant equal on the linear shaft.

In the same way, it is to clean the linear shafts on left and right rail beams.

Base on the using frequency, look-over whether the lube of guide rail is enough or not termly (once every 15 days or 2 months), use the lube with 32-150cst to lubricate the guide rail.

Operation steps:

- Stop the machine, switch off the power supply;
- Take apart the guard (or synchronous belt), show up the oil nipple of linear guide;

- Using oil gun, make the oil nipple of oil gun aim at the oil nipple of slipper, offer oil;
- Install the guard (or synchronous belt) again.
- Switch on the power supply, start the machine.

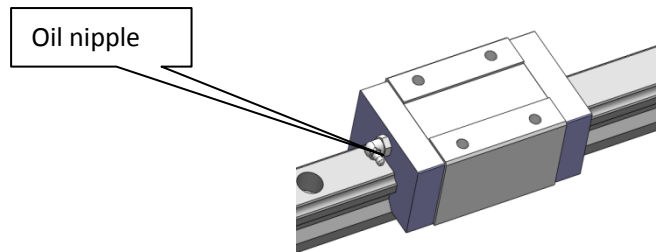

Fig.4-1 Oil nipple of linear guide

4.1.2 Synchronous belt, synchronous belt wheel

Synchronous belt and synchronous belt wheel are the main mechanical parts of the machine, and they control movement track of the laser head. After movement for a certain period, the synchronous belt will frequently be longer and loose in a small size. That will lower the accuracy and sensibility of the laser head; therefore, timely adjusting the transmission belt is needed.

Adjustment method: Adjustment of X direction and Y direction synchronous belt should achieve a proper tension of it; adjustment of drive motor synchronous belt is to achieve that when pressing middle part of the synchronous belt, the sinking level is 3% to 5% of the central distance between the belt wheel at the two ends.

Attention:

① If to adjust the transmission belt too tight, the belt is not only easily made distortion but also cause more severe abrasion of the bearing; if too loose, transmission accuracy and sensibility will be lowered. Therefore, you should adjust the synchronous belt at a proper tension. While adjust Y direction synchronous belt, it is to achieve a proper ten for the synchronous belt and make the left and right synchronous belts at the same tension. Only by this way, a stable transmission synchronous belt can be achieved to ensure a good carving and cutting effect of the product.

② Keep the synchronous belt away from oil, pr chemicals. Contact with acid, alkali, oil and organic solvent is prohibited. Keep the synchronous belt dry and clean.

③ There is problem of aging with rubber of the synchronous belt. In case of serous aging (or abrasion), timely replacing with a new one is required. Please note that synchronous belt wheel should also be replaced if to replace the synchronous belt.

After using the synchronous belt for a certain period, loose belt and abrasion will also be caused, and then timely replacement and lockup are needed. Please note that the new synchronous belt should match with the synchronous belt wheel.

4.1.3 Fasten screws and coupling

After working for a certain period, the screws at movement joints and the coupling of the movement system may be loosen causing low stability of mechanical movement. Therefore, during movement of the machine, you should observe if there is abnormal sound or other abnormality with the movement parts. In case of problems found, timely fastening and maintenance are needed. Meanwhile, the screws of the machine should be tightened one by one with tool after a certain period of use. The first fixation should be performed roughly one month later after using.

4.2 Electric maintenance

Electric maintenance mainly includes the maintenance for electric parts, sensor, operation buttons and working indicator of the machine.

4.2.1 Limit switch

Minimum once a month to make check on the effectiveness of limit switch of the X-axis and Y-axis. The limit switch plays the role of restraining the limit position of the movement to avoid machine impact (overreaching) causing damage to the machine. It is a must to make regular check on working state following the steps below:

1. Start up the machine to have the laser head reset;
2. Operate the machine to make the movement shaft move to the limit positions. If the movement shaft stops at the limit position, it means a normal operation of the limit switch. If it keeps moving while reaching the limit position, it means that the limit switch is out of order.

 Note	In case of hard impact occurs, please immediately press the emergency stop button to stop the machine, and find a solution for it.
---	--

4.2.2 Stop button

Stop button is the safe emergency organ of laser cutting machine; it is relative with the safety of personal property and machine. You must look-over its functions follow the following steps in the maintenance interval time of this manual.

- Turn on the laser cutting machine and cutting;
- Press stop button. If all the power supply of the machine has been switched off, the safe electrocircuit of stopping is normal. There are 2 stop switches, one is at machine shelves and another is on the operation terminal, you should look-over them with this method one by one.
- Reset the stop button, restart the machine.

4.2.3 Maintenance of other button and indicators

After disconnecting the related electric parts, test button contact points with a millimeter to check they are normal in operation.

Purposely trigger all working modes and alarm state to check if warning indicators and signal indicators are normal.

4.3 Light route and optics parts maintenance

Light route system of the laser engraving machine is completed by reflector together with focus of the focusing lens. The focusing lens is free of the problem of deviation in light route. However, three reflectors are fixed by mechanical parts with large possibility of deviation. Although deviation is not frequently caused, users are recommended to have a check on the light route before working each time.

Although the optical lenses in CO₂ laser system are easily worn products, we still wish you try to use it less as possible to prolong lifespan of the laser device and lower cost of using lens.

During replacement, pay attention to placing, testing, installing the optical lens to keep it free of damage and pollution. After installing a new lens, regular cleaning is needed. This is very simple. Proper operation will prolong lifespan of the lens and lower cost. Otherwise, the lifespan will be shortened.

During laser working, it is inevitable to prevent the optical parts from contacting the suspended particles. When cutting the materials, engraving and marking with laser, processing surface will release plenty of gas and flying objects. The gas and flying objects may cause harm to the lens. When dirt falls on surface of the lens, it will absorb energy from the laser beam causing thermal-lens effect. In case of no thermal stress formed on the lens, the operator may take it down and clean it. Of course, a certain method capable of avoiding damage and further pollution should be applied.

- General rules of operation

During cleaning and installing the lens, any matter stuck on or even nail print or oil droplet may higher absorption of the lens and shorten lifespan of it. Therefore, the following prevention measures must be taken:

- 1) Suction or blowing device are prohibited to avoid scratch on surface of the lens caused;
- 2) Do not touch film layer of the lens when taking it out, but to hold its edge;
- 3) Keep the lens at dry and clean place for testing and cleaning. A good working table should be equipped with several layers of cleaning paper or lens cotton paper on the surface;
- 4) The operator shall not speak over the lens, and keep food, beverage and other pollution matter with potential risk away from the working environment.

- Correct leaning method

During cleaning the lens, the only objective is to remove pollution on the lens, but not cause further pollution and damage to the lens. To achieve this goal, people usually take the method with less risk. The followings are just for this purpose:

Firstly, use air balloon to blow off particles on surface of the lens, especially the micro particles and floccules on the lens. This is a necessary step. Yet, compressed air of the production

line is strictly prohibited. This is because the air from it contains oil and moisture, and that will cause further pollution to the lens.

Secondly, gently clean the lens with acetone or absolute alcohol (Absolute alcohol is necessary. It may lower the possibility of pollution to the lens.)

After soaking acetone, use the lens paper to clean the lens under sunshine and move in a circle. When the paper gets dirty, it is a must to replace it. Cleaning must be done in a one-off way to avoid scratch caused.

Certainly, some pollution and lens damage cannot be removed by cleaning, e.g. film burn by dirt, film peeling off by dew or condensate water. To recover its good performance, the only way is to replace the lens.

4.4 Machine visual maintenance

Camera lens stays at the air chronically. Pay attention to the soot pollute the lens when working. The machine vision module may not work normally, collected graph is unclear and the look-over object may be missing or unfaithful with the polluted lens.

- Turn on air blower and exhaust blower when machine working, ensure the flowing exhaust and smoke of machine;
- Please cover the lens by the cover or dustproof bag when you don't use the machine for a long time;
- If the lens have spots, using cotton stick to clean. You can consult the maintenance of focus lens.
- Avoid motorial vibration of machine and impact by outside force, otherwise, the lens may be disrepaired.

4.5 Auxiliary parts maintenance

4.5.1 Water replacement and water tank cleaning

Water quality of the circulation water will directly influence lifespan of the laser tube. You are recommended to use purified water, and keep the water at a temperature below 35°C. In case of over 35°C, water replacement is needed, or place ice into the water to lower its temperature. (You are recommended to select water chiller or use two water tanks.)

It is recommended to clean the water tank and replace the circulation water once a week. Water tank cleaning: firstly disconnect the power supply, plug water inlet pipe out, have the water inside the laser tube automatically flow into the water tank, open the water tank, take the water pump out, and clean dirt on the water pump. Thoroughly clean the water tank, replace ready the circulation water, place the water pump back into the water tank, insert water pipe connecting the water pump into water inlet, well arrange all the connectors. Separately connect power through to the water pump for running 2-3 minutes (make the laser tube fill up with water.)

4.5.2 Blower cleaning

For every 15 days, it is to clean the air pipe, and blower to prevent foreign matters accumulated from lowering effect of air out. Check if there is leakage, foreign matter, perform repair or maintenance. Long-term use of blower will cause plenty of solid dust accumulated inside the it causing large noise and lower effect of air exhaustion ventilation and smell elimination. In case of insufficient suck force causing unsmooth smoke expelled, firstly power it off, remove the air-in pipe and air-out pipe from the blower, remove dust inside them, and then turn the blower upside down, and push the blade of it till it getting clean, and then assembly the blower ready for use.

4.5.3 Water chiller maintenance

Water quality and temperature of the cooling water will directly relate to lifespan of the laser tube or radio frequency tube. Cooling water must the purified water at temperature below 35°C; the cooling water must be kept clean and regularly replaced (minimum once a month). Check if the cooling water gets muddy, with deposit, at over high temperature, or water replacement required; during processing, frequently check water level to ensure sufficient water or if the water temperature is over high (higher than 35°C).

Steps of replacing cooling water:

1. Power off the machine and stop the laser device;
2. Unscrew valve of water outfall of the water chiller for a thorough drainage of water from the water chiller;
3. Open protective cover of the water chiller and pour purified water into the water chiller;
1. Start up the machine; observe if the laser tube is filled up with water. After circulation for five minutes, if there are still plenty of air bubbles in the laser tube; it is to open the discharge valve inside the machine to expel air from the laser tube making cooling water fill up with the laser tube.

Chapter 5 Trouble Shooting

No.	Failure	Analysis Method	Solution
1	Machine cannot power on	<ul style="list-style-type: none"> ● Check whether the stop button press 	<ul style="list-style-type: none"> ● Loosen stop button
		<ul style="list-style-type: none"> ● The master contactor inside the electrical box trip 	<ul style="list-style-type: none"> ● Reset master contactor
2	Laser power supply cannot power on	<ul style="list-style-type: none"> ● The cooling system hasn't been turned on normally 	<ul style="list-style-type: none"> ● Open the water cycle system
		<ul style="list-style-type: none"> ● Water protection touch off (the sensor broken) 	<ul style="list-style-type: none"> ● Check the sensor of water protection
		<ul style="list-style-type: none"> ● The air switch of laser power supply inside the electrical box trip 	<ul style="list-style-type: none"> ● Close the air switch of laser power supply
3	Alarm given after power-on	<ul style="list-style-type: none"> ● If parameters of the controller are correct ● Machine alarm signal is triggered 	<ul style="list-style-type: none"> ● Correct parameters of the controller ● Check alarm signal source of the machine
4	Laser pause during working	<ul style="list-style-type: none"> ● Check if water circulation is smooth 	<ul style="list-style-type: none"> ● Clean water tank, dredge water hose
		<ul style="list-style-type: none"> ● If power voltage is table 	<ul style="list-style-type: none"> ● Install a stabilizer to input power supply
5	Wrong figure size	<ul style="list-style-type: none"> ● User adopts PLT output in CorelDraw software. In HGPL dialogue box, if unit of plotter in page option is set correct 	<ul style="list-style-type: none"> ● PLT plotter unit out from CorelDraw software should match with resolution of SmartCarve software lead-in PLT option
		<ul style="list-style-type: none"> ● User adopts PLT output in CorelDraw software. In HGPL dialogue box, if zooming in page option is 100% 	<ul style="list-style-type: none"> ● Change to 100%
		<ul style="list-style-type: none"> ● If resolution of the controller parameters are correct 	<ul style="list-style-type: none"> ● Set to the correct resolution or equivalent
6	Crash to the machine and unexpected engraving	<ul style="list-style-type: none"> ● Discharge and sparkle of the laser tube (high voltage line) to case 	<ul style="list-style-type: none"> ● Reconnect the laser tube high voltage line
		<ul style="list-style-type: none"> ● Fail to connect earthing for the controller or other interferences 	<ul style="list-style-type: none"> ● Connect earthing, eliminate the interference
		<ul style="list-style-type: none"> ● Over high temperature causes crash to the controller 	<ul style="list-style-type: none"> ● Add more measures for lowering temperature

7	Reverse direction of motor shaft movement	<ul style="list-style-type: none"> ● If lines from the drive to the motor are connected improperly 	<ul style="list-style-type: none"> ● Check electric earthing
8	Fail in movement of motor shaft or twittering of it during movement	<ul style="list-style-type: none"> ● Improper setting of motor parameters cause missing step to the motor ● Damaged drive or motor ● Motor line broken or poor contact 	<ul style="list-style-type: none"> ● Set to the correct movement parameters ● Change the drive or motor ● Reconnect the motor and drive line

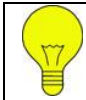

Note

Please refer to operation instructions of the machine vision system for the related controller for more details concerning failure diagnosis.

Appendix

Appendix 1 Electric control system figure

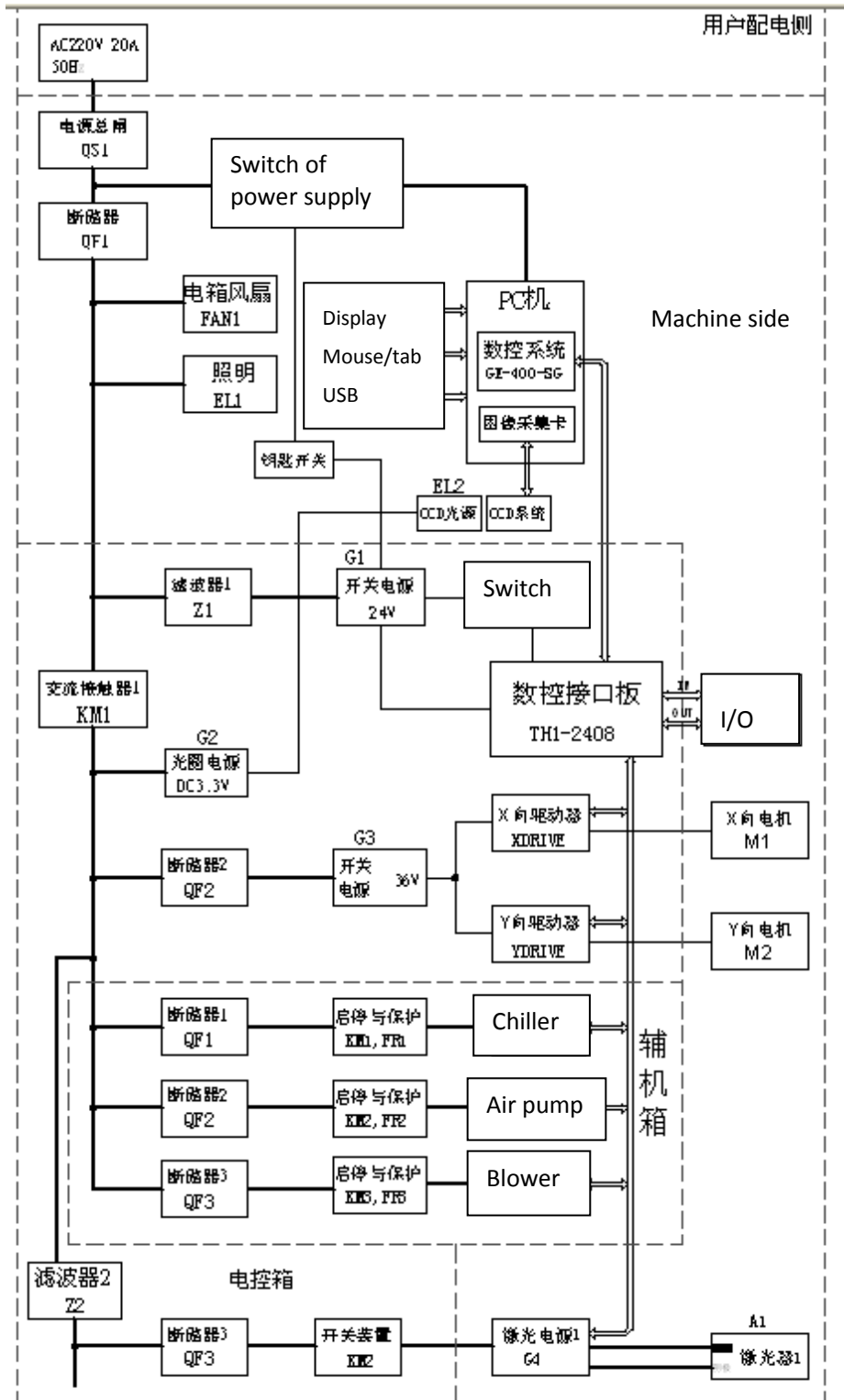

Appendix 2 The control elements figure of main power supply

AC220V 20A 50/60Hz

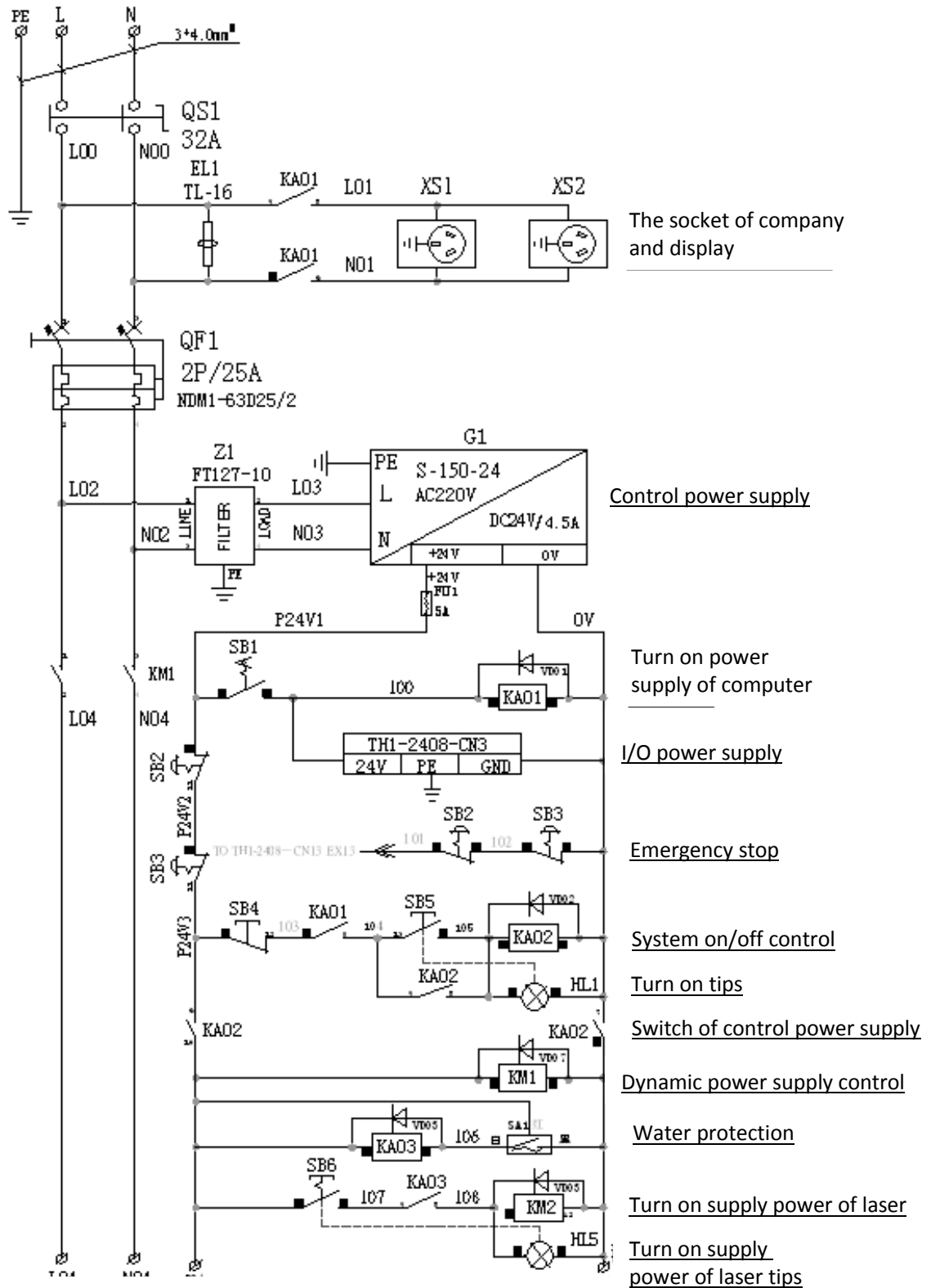

Post

All final right of interpretation of this manual belongs to our company; we will do our utmost efforts to ensure the accuracy of the contents of this manual. We do not assume any responsibility caused by misspellings and typing errors. Your comments will be highly appreciated.

All rights reserved! Reprinting or copy without permission is prohibited. We reserve the right of lawing.



0 7 0 2 0 1 0 0 3 4 4

CNY: 50.00