

---

**A new generation of intelligent Pattern  
machine control system  
Operation Instruct**







## Objective

Welcome to use the company's special sewing machine control system. Please read this manual carefully to ensure the correct operation, use of special sewing machines, please follow the instructions in this manual, otherwise, such as the damage caused by the violation of the company does not assume responsibility. In addition, please keep this user's manual in a safe place for inspection at any time. In case of failure, the error shall be repaired by the technicians or professionals which designated by the Company.









## Security Considerations

















### 1. Signs and meanings of safe operation



The use of the instructions and products used in the safety logo is to enable you to properly and safely use the product to prevent you and other people from being harmed. The logo and its meaning are as follows:

 危险	If you ignore this tag and do the wrong operation, you can cause serious injury or death.
 注意	If you ignore this tag and do the wrong things, you can cause injuries and damage to your equipment.
	The symbol denotes "considerations". The pattern in the triangle indicates what must be noted. (for example, the pattern on the left says: "Beware of injury")
	The symbol indicates "Prohibit".
	The symbol means "must." The pattern in the circle indicates what must be done. (for example, the pattern on the left says "must be grounded")

### 2. Safety precautions

 危险	
	When opening the control box, turn off the power switch and unplug the power plug from the socket, wait for at least 5 minutes before opening the control box cover. Touching areas with high voltages can cause injuries.
 注意	
<b>Use environment</b>	
	The use of this sewing machine should be avoided in the vicinity of strong electrical interference sources such as high-frequency welder. A strong electrical interference source may affect the normal operation of the sewing machine.
	The fluctuation of the power supply voltage should be used under the condition of $\pm 20\%$ of the rated voltage. Large voltage fluctuations will affect the normal operation of sewing machines, need to be equipped with a voltage regulator.
	The ambient temperature should be used within the 5 °C ~35 °C range. Low temperature or high temperature will affect the normal operation of the sewing machine.
	The relative humidity should be in the range of 45%~85%, and the equipment will not be used in the condensation environment. The drying, damp or dew environment affects the proper operation of the sewing machine.
	Compressed air supply should be greater than the total consumption required by sewing machines. Insufficient air supply will cause the sewing machine to be abnormal.
	In the event of a thunderstorm, turn off the power switch and unplug the power plug from the socket. Lightning may affect the proper operation of the sewing

	machine.
<b>Installation</b>	
	Please have trained technicians to install the sewing machine.
	Do not connect the power supply until the installation is complete. If the start switch is mistakenly pressed, the sewing machine action can cause injury.
	When the head of the sewing machine falls or stands up, use your hands. Don't press the sewing machine hard. If the sewing machine loses its balance, the sewing machine slips to the ground causing injury or damage to the machine.
	Must be grounded. The connection ground wire is not firm, is causes the electric shock or the false action.
	All cables should be fixed at least 25mm away from the active part. In addition, do not bend excessively or fasten tightly with the clamp. Can cause a fire or an electric shock.
	Please install a safety cover on the nose.
<b>Sewing</b>	
	This sewing machine is limited to those who have been trained in safe operation.
	This sewing machine cannot be used for any purpose other than sewing.
	You must wear protective glasses when you use a sewing machine. If you do not wear protective glasses, break the needle break part of the needle may be able to bounce into the eyes caused damage.
	Turn off the power supply immediately if the following conditions occur. Otherwise, when the start switch is mistakenly pressed, it can cause injury. 1. Needle Threading 2. When the needle is replaced 3. When the sewing machine is not used or when the person leaves the sewing machine
	During the sewing process, do not touch any moving parts or lean the objects on the moving parts, as this can cause injury to the person or damage to the sewing machine.
	If the sewing machine operation in the wrong action, or hear abnormal noise or smell abnormal smell, should immediately cut off the power. Then please contact the Purchasing shop or trained technician.
	If the sewing machine fails, contact the purchase shop or trained technician.
<b>Maintenance and inspection</b>	
	Only trained technicians can carry out repair, maintenance and inspection of sewing machines.
	Related to electrical maintenance, maintenance and inspection, please contact with the professionals of the electronic control manufacturers in time.
	Turn off the power supply and unplug the power plug when the following conditions occur. Otherwise, when the start switch is mistakenly pressed, it can

	cause injury.1.Inspection, adjustment and maintenance 2.Replacement of wearing parts such as bent needle, cutter, etc.
	Before checking, adjusting and repairing any use of pneumatic equipment, please disconnect the gas source and drop the pressure gauge pointer down to "0".
	When you must connect the power switch and the source switch to adjust, be sure to observe all safety precautions carefully.
	The damage to the sewing machine caused by the unauthorized modification of the sewing machine is not covered by the warranty.

## 1 Summary description

### 1.1 Overview

This series of industrial sewing machine computer control system, spindle motor with the world's advanced level of AC servo control technology driven by a large torque, high efficiency, speed stability and low noise characteristics. Operation Panel design diversified to meet the requirements of different customers, the system adopts German structure design, convenient installation and maintenance, system control software can be upgraded through long-distance communication, user-friendly continuous improvement of product performance.

### 1.2 Technical parameter Table

	机 型 项 目	Sewing machine with lockstitch sewing pattern (with large rotary hook)
1	Trace form	Single Needle Flat seam
2	Max Sewing Speed	2,800rpm
3	Sewing size (X×Y)	GSM-1310G Max: 130×100mm;GSM-2210G Max: 220×100mm
4	Feed the cloth to drive the way	Intermittent delivery cloth (pulse motor drive)
5	Needle distance	0.05-12.7mm
6	Number of needles	Memory 500,000 stitch (※)
7	Maximum number of needles	20,000 stitch (1 pattern)
8	Storing data that might be sewn	Memory: 999 (※) .USB: Unlimited
9	Lifting Foot Drive mode	Electromagnetic specification: Pulse motor Drive, Air pressure specification: air pressure type
10	Presser Foot Rise	Electromagnetic specification: Max 25mm, air pressure specification: Max 30mm
11	2-Step Press foot	Electromagnetic Specifications: Left and right one pressure foot, air pressure specifications: Left-right split-type presser foot
12	Intermittent presser foot rise amount	22mm
13	Intermittent Presser Foot Stroke	2-4.5mm、4.5-10mm/0 (Factory setting: 3mm)
14	Use of the Rotary Shuttle	Half turn 2- times hook (standard hooks are option)
15	Buckle Line Device	Standard
16	Tangent device	Standard
17	How data is stored	Memory (Fast erase memory), CF card

		(32,64,128,256MB)[Option]3.5 Disk 2HD/1.44MB.2DD
18	Number of user programs	50
19	Number of loop programs	9
20	Motor	AC servomotor 550W
21	Weigh	Head: about 88kg, Operating panel: about 0.6kg Control box: 14.2-16.2kg ( according to different countries )
22	Power	Single phase 100V/220V、3-phase 200V/220V/380V/400V 400VA
23	Air pressure	0.5Mpa 1.81/min

▶ **Maximum sewing speed Please reduce speed according to sewing condition.**

## 1.3 Precautions for safe use

### ● Working Environment

This control device should not be used in the following environment:

- ◆ Power supply voltage
- ◆ voltage changes will exceed the fixed voltage of more than 10% places.
- Power supply capacity cannot be ensured at the specified capacity of the sit
  - ◆ Radio interference
- Nearby is a place with radio transmitters and high-frequency machines that emit strong radio and magnetic fields.
- Temperature and humidity
  - ◆ A place at room temperature between 0°C~50°C.
  - ◆ Outdoor or daylight will be directly exposed to the site.
  - ◆ The place beside the radiator (electric heater).
- Relative humidity in the place between 5%~95% (no condensation).
- Air
  - ◆ A corrosive or dusty place.
  - ◆ A place where gas explosions or oil explosions are likely to occur.
  - ◆ Vibration
- The place where the sewing machine is placed is prone to excessive vibration, place the control box elsewhere.

### ● Installation

- Control box
  - ◆ Please follow the instructions correctly.
  - ◆ Annex
  - ◆ To install additional accessories, please turn off the power and unplug the power.



- Power cable
  - ◆ Please do not use gravity to press the power cord or excessive twisted power cord.
  - ◆ Please do not close the power cord to the rotating part, at least more than 25mm away.
- Control box to access the power before, please check to see if the power supply voltage and the control box on the same voltage and determine the location of the power supply. If you have to use the power transformer, the same need to check before you can supply power. The button-type power switch on the sewing machine must be put on [off].
  - ◆ Grounding
  - ◆ In order to prevent the noise and leakage of electric shock events, the power line grounding wire must do a good grounding.
  - ◆ Accessory device
  - ◆ If you want to receive electrical accessories, please follow the directions.
  - ◆ Disassemble
  - ◆ To remove the control box, you must first turn off the power and unplug the power.
  - ◆ When pulling off the power plug can not only pull the power cord, must be holding the power plug to pull out.
  - ◆ There is a dangerous high-voltage in the control box, so to open the lid of the control box, you need to turn off the power supply and wait more than 5 minutes before you can open the lid of the control box.

## ● Maintenance, inspection and repair

- Repair and maintenance of the work, to be trained technicians to carry out.
- When replacing the machine needles and the shuttle, be sure to turn off the power.
- Please use the parts of the factory.

### ■ Other safety measures

- Do not touch the parts of the sewing machine that will rotate and move (especially the machine pin and belt accessories), and note that the hairs should not be near them to avoid danger.
- Control device must not fall to the ground, and not to the gap between the other items.
- Please do not operate in the case of removing the cover.
- If the control device is damaged or not functioning properly, it is necessary to ask experienced technicians to adjust, or check the repair, before the failure has not ruled out please do not run it.
- Please do not modify or change the control device.

● **Warning signals and danger signals**

- The wrong behavior can be dangerous, as described in the following indication of the difference.

 <b>警告</b>	错误的行动可能会发生重伤或死亡。	 <b>注意</b>	错误的行动可能会发生伤害或房屋或财产的损害。
---	------------------	---	------------------------

- The indication of the symbol is as follows.

	请遵照指示内容作业。		注意高压电 (电击) 的危险。
	注意高温。		务必接上接地线。
	绝对不要执行。		



● **Waste disposal**

- Please take the general industrial waste disposal.

**1.4 Precautions to use**

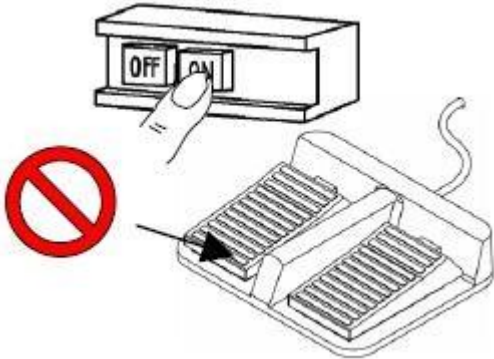
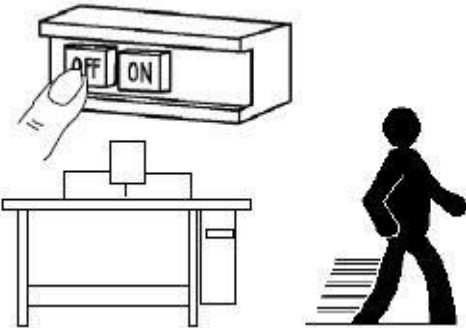

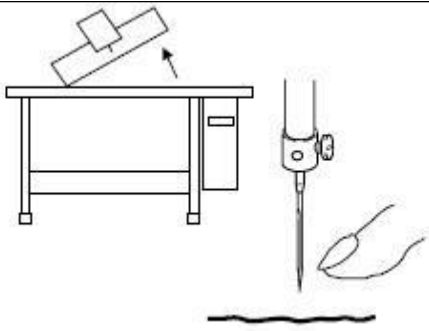
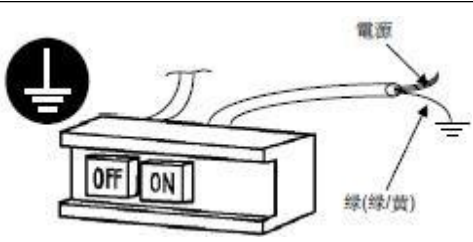
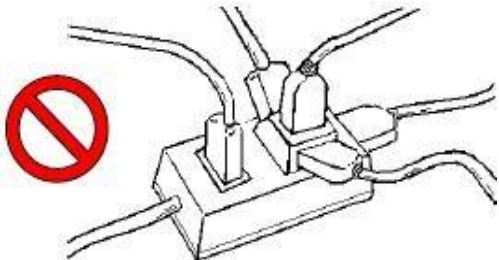
<p>1、 When the hand presses the switch [on], the foot is set to leave the pedal.</p> 	<p>2、 Be sure to turn off the power when you want to leave the job.</p> 
<p>3、 Be sure to turn off the power when you want to cross the head or replace the PIN or the face line.</p>	<p>4、 Grounding wire should be well grounded.</p>

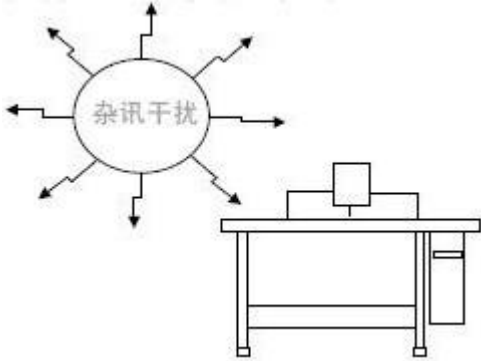
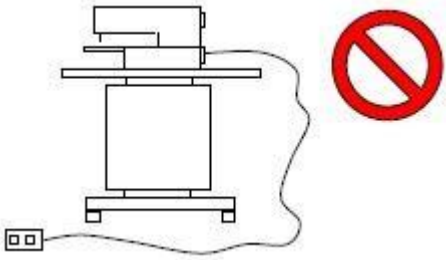
	
<p>5、 Do not use the home with multiple jac k extension cord.</p> 	<p>6、 There is a dangerous high-voltage po wer inside the control box, so wait 5 mi nutes after turning off the power supply to open the lid of the control box.</p> 
<p>7、 After the replacement of the motor, it is important to refer to this information to set the angle of the spindle motor installation.</p>	
<p>8、 Keep away from machines that produc e high-frequency noise.</p> 	<p>9、 If the use of external signal sockets t o connect the application of accessories, the length of its connector can be as s hort as possible, the long line may lead to false action, cable cable, please use isolation.</p> 
<p>10、 If the fuse is burnt, please first remove the reason and change the same capaci ty of the fuse.</p>	



## 1.5 Standardization

The function key uses the industry recognized graphic identification, the graph is the internationalization language, the national user can recognize.

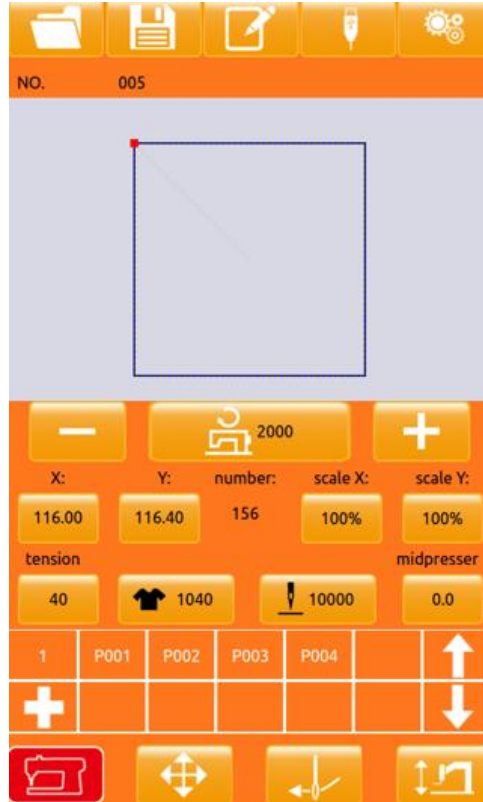

## 1.6 Mode of operation

This System touch screen operation panel uses the industry advanced touch Operation Technology, the friendly interface and the convenient control all brings the innovation change to the user's daily use. Users can use their fingers or other objects to touch the screen to complete the operation.

Users should be careful to avoid the use of sharp objects touch the screen, so as to avoid permanent damage to the touch screen. function keys include preparing keys, information keys, mode keys, and communication keys. The specific method of action refers to the instructions in the following sections.



Users should be careful to avoid the use of sharp objects touch the screen, so as to avoid permanent damage to the touch screen.

## 2 Operation Instructions

### 2.1 Universal Keys

The key buttons for general operation in this system are as follows:

NO.	Icon	Function
1		Confirmation key → input interface to enter the sewing interface/sewing interface to exit to the input interface
2		Information key → View version information and threading diagram
3		Communication key → u disk and panel communication, the pattern or parameters of the mutual copy
4		Set key → Enter function interface
5		Pattern Selection key → open pattern file
6		Registration key → registration pattern file number
7		Name key → Enter pattern name
8		Adjust key → Adjust starting seam point
9		Threading key → Threading
10		Cancel key → Cancel current setting/exit Current interface
11		Confirm key → Save current set value
12		Test seam key → Enter one step seam interface
13		Winding key → into winding state

## 2.2 Basic operations

### ① Turn on the power switch

When the power is turned on, the data entry interface is displayed.



### ② Select the pattern you want to sew.

The selected pattern no is displayed under the current interface, Press the pattern select key  Enter the sub-menu to select the pattern No..

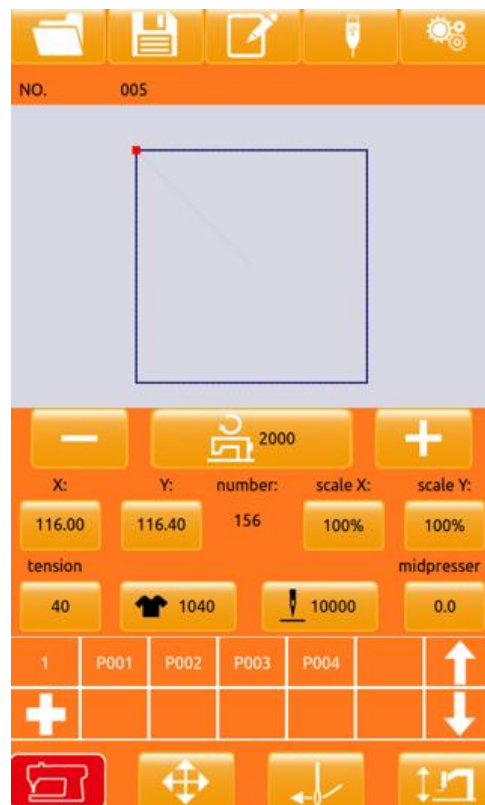
For the operation of pattern selection, see "2.8 Pattern Selection" section.



### ③ Set to a state that can be sewn

After pressing the  , when the color turn to  To enter a pattern to confirm the interface, at this time the state can be sewn.

### ④ Start Sewing

Put the sewing products to the pressure feet, pedal down the foot, the sewing machine started, sewing started.

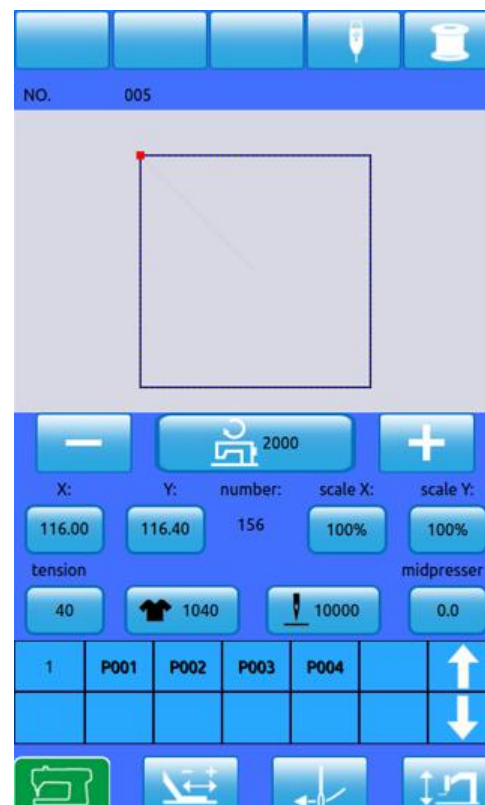

## 2.3 Ordinary pattern operation

### (1) Sewing Data Entry interface

The data entry interface is shown in the image on the right, please see the Function key Description table for detailed function description.

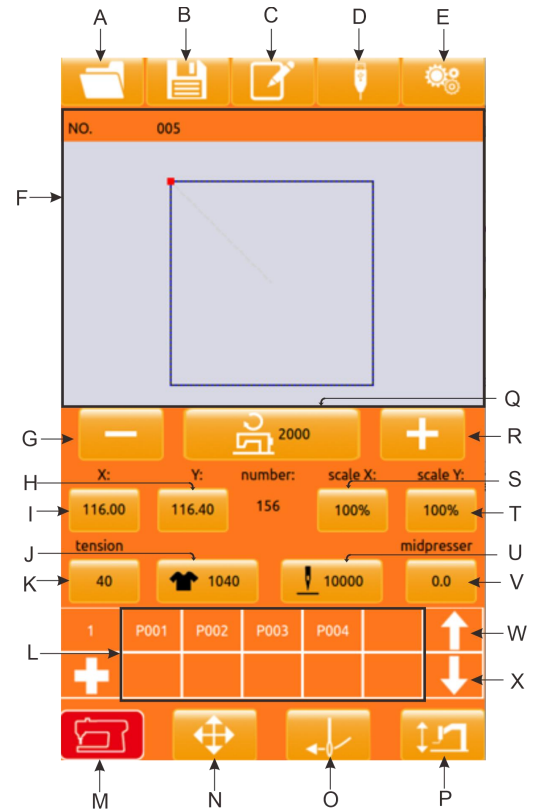

### Function Description:

NO.	Function
A	Pattern Selection Key
B	Pattern Registration key
C	Pattern naming key
D	USB flash disk key
E	Set key
F	Pattern Graphic Display Area
G	Speed decrease key
H	Y zoom key
I	X Zoom rate Key
J	Counter key
K	Tension keys
L	P Pattern Shortcut key area
M	Pattern confirmation button
N	Adjust the seam point key
O	Information query key
P	Threading key
Q	Speed keys
R	Speed increase button



<b>NO.</b>	<b>Function</b>
S	X zoom key Counter Mode key
T	Y Zoom rate Key Count Key
U	Needle counter key
V	Pattern naming key
W	P Pattern Page Up key
X	P Pattern Page Down key

**(2) Sewing interface**

Press  enter the sewing interface as shown in the picture on the right. See the Function Key Description table for detailed function instructions.

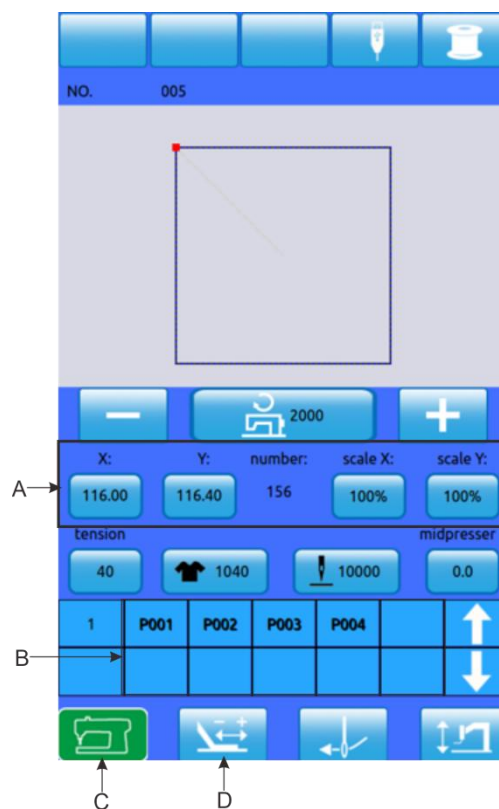

**Function Description:**

NO.	Function
A	Zoom button area (not operable)
B	P pattern area (uncomfortable)
C	Exit pattern confirm button
D	Test Seam Key
---	Other keys with input interface function

## 2.4 Pattern Registration

You can register up to 999 ordinary tricks.

Press  into the Pattern registration interface (as shown in the right image):

### ① Enter pattern number

Through the number of keys can choose to enter the pattern number, pattern number range must be 201~999, if the input of other numbers will show out of the range of numbers.

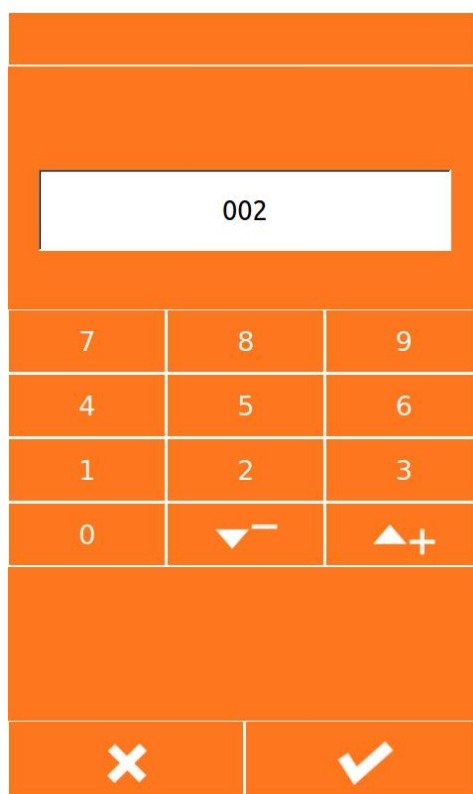

### ② Registration new pattern

Confirm the pattern number and press , Before the display of pattern data will be copied to the New registration pattern, the operation is returned to the new registration pattern data entry interface.

If the entry number has been registered the number will prompt to overwrite the saved pattern.

After pressing  Exits the registration interface.

## 2.5 Pattern naming

Press  Go to the Pattern naming interface (as shown in the picture on the right).

A	Delete	Delete input characters individually
B	Move right	Move the cursor to the right
C	Move left	Move the cursor to the left
D	Empty	Empty all characters that are currently entered

Select the character you want to enter,

press  ends the pattern naming operation.

The position of the character can be determined by moving the cursor, and the DELETE key eliminates the location character.

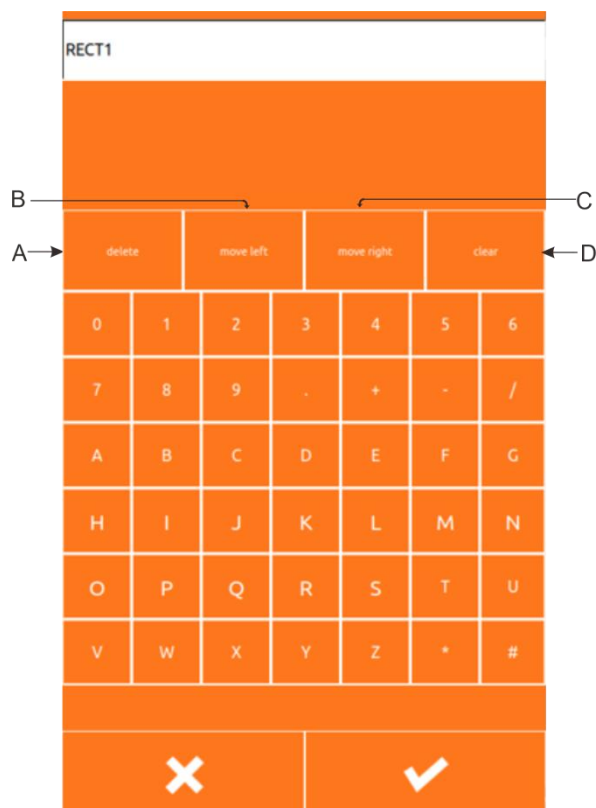

## 2.6 Winding

### ① Install Bobbin

Insert the spindle into the winding shaft.  
As shown in the picture on the right.

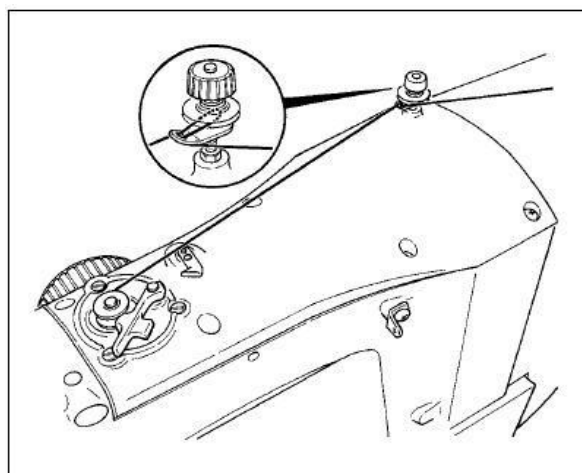

### ② Show Bottom Line Winding interface

In the sewing interface, after pressing  the winding button, the winding interface is displayed (as shown in the image on the right).

### ③ Start winding

After treading the left pedal and pressing the foot, the pedal starts winding.

### ④ Stop sewing machine

After the wound is started, the pedal starts again and the winding stops spinning, and the foot of the left pedal is lifted back to the sewing mode after winding stop.

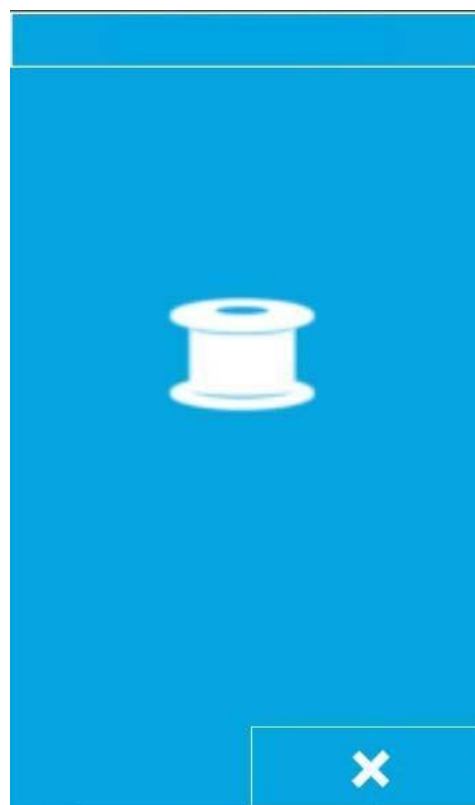

## 2.7 Threading

### ① Into the threading state

In the input interface or the Sewing interface  , the screen changes as shown in this state, the machine can not perform other operations.





### ② Exit Threading Mode

After the thread is over, press the exit button again to return to the input interface or sew.

### 2.8 Pattern Options

#### ① Into the pattern selection interface

Data entry interface (shown in Figure 1 on the right), click on the Select button A to enter the Pattern selection interface (Figure 2). Figure 2 The following information:

A	Pattern name
B	Pattern size Information
C	Pattern Graphic Display
D	Registered pattern number
	Flip on the pattern
	Turn the page in a pattern
	Pattern deletion

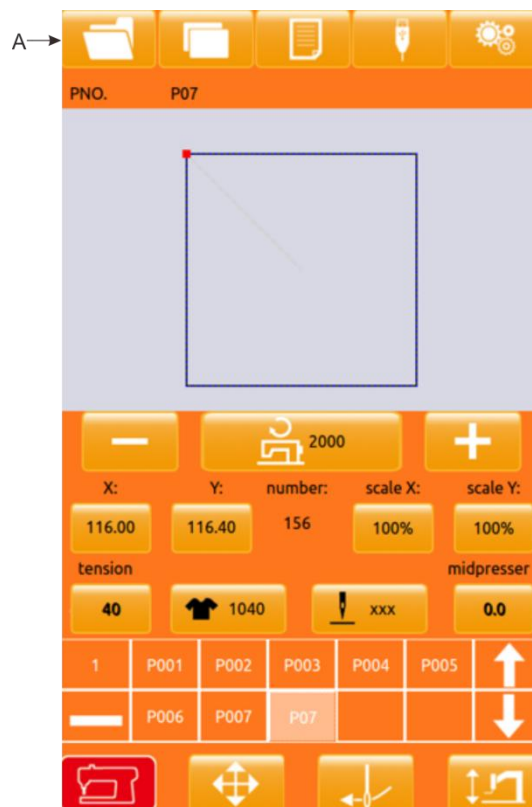

#### ② Select pattern

Pattern Number Area D each page can display 25 pattern numbers, select a pattern number button, the current pattern graphics and information displayed above. The pattern information contains the pattern number, the x direction length, the y direction height, the pattern named string (the unnamed pattern does not display the string).

Press  Complete the pattern selection operation.

#### ③ Pattern Deletion

Select a pattern Number button, press the key

 will remove the pattern.

**Note:** The pattern is divided into basic patterns and common patterns:

the basic pattern for the factory pattern, the ordinary pattern for the user to play version, copy or U disk import patterns, patterns can be deleted and modified, but remove the pattern will not be retrieved, please proceed with caution.

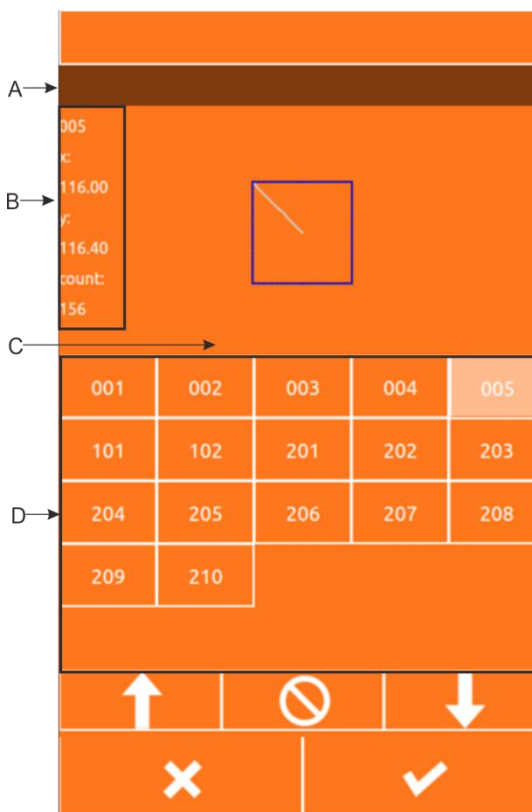

## 2.9 Sewing data Setting

### ① Enter the sewing data setting interface

Under the data input interface, press A, B and C to enter the zoom setting and the speed Limit setting interface respectively.

	Item	Input range	Initial value
A	Sewing speed	400~2800rpm( The upper limit is set in the Super settings parameter)	2000rpm
B	Y-direction enlargement and reduction ratio	1.0~400.0%	100.0%
C	X-direction enlargement and reduction ratio	1.0~400.0%	100.0%
D	Tension	0~120	40
E	Middle Pressure Foot height	0.0~7.0mm	2.0mm

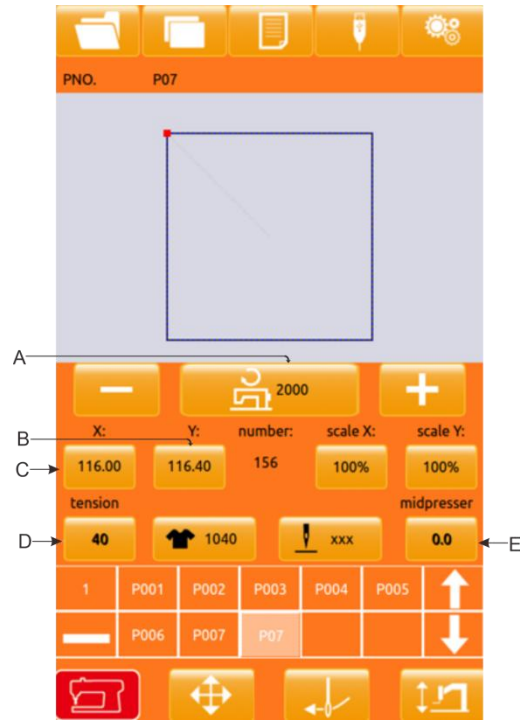

Note: Maximum speed limit is limited in "super setting → parameter setting → 3: Maximum sewing speed".



② Zoom rate Setting

The right image is the magnification setting interface, with the X orientation above the interface and the Y direction setting below.

A	X direction Zoom Rate Display
B	X direction actual Length value display
C	Y-Direction Zoom rate Display
D	Y-direction actual height value display

Through the numeric keypad or +,-key to enter the desired value, the input number inserted into the display number first, the previous input of the number of a progressive, press the

OK  key to complete the operation to return to the data entry interface.

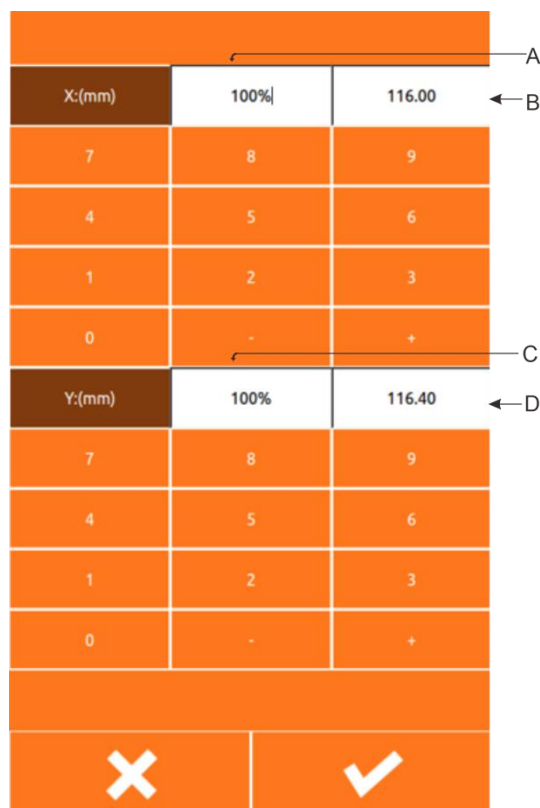

③ Speed Setting

Operation Ditto

④ Middle pressure foot height value setting

Operation Ditto

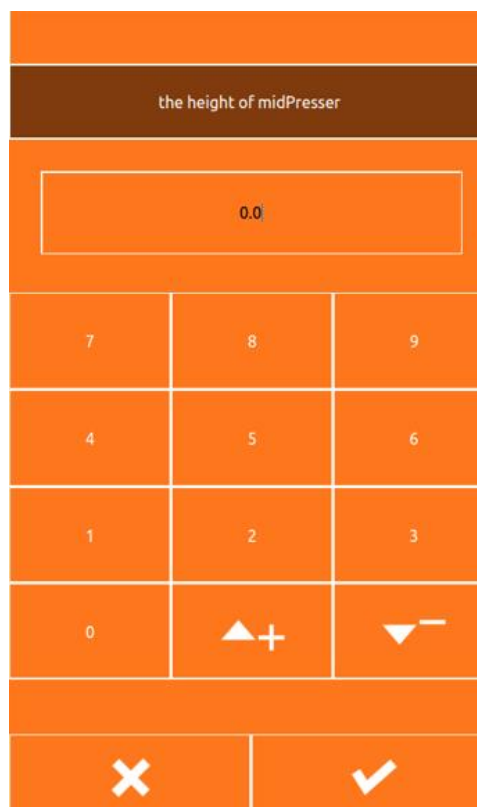





## 2.10 P Pattern Registration

### ① Enter P Pattern Registration interface



Under the data input interface to display the normal pattern of the case press  into the P pattern registration interface, such as the right image.

### ② Enter P pattern number

Through the  ~  Ten-character keyboard or ,  key enter the number you want to register, and if you enter a pattern number that is already registered, you will be prompted to use the number, which requires the user to re-enter the number you want to register.

### ③ Select folder Number

The P pattern number can be registered in 26 folders, with a maximum of 10 p patterns per folder.

A is the current folder, press, key ,  to switch folders.

### ④ Determine the pattern number

After pressing the OK key  Completes the P pattern registration operation, returns to the P pattern data data input interface, as shown in the figure.

### ⑤ Delete P pattern

Select the p pattern number, press the delete  key, you can delete the current p pattern number.

### ⑥ View Registered P pattern

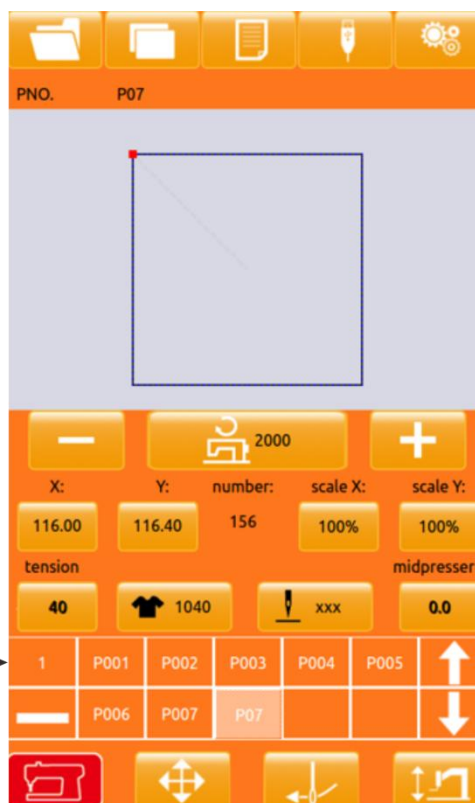
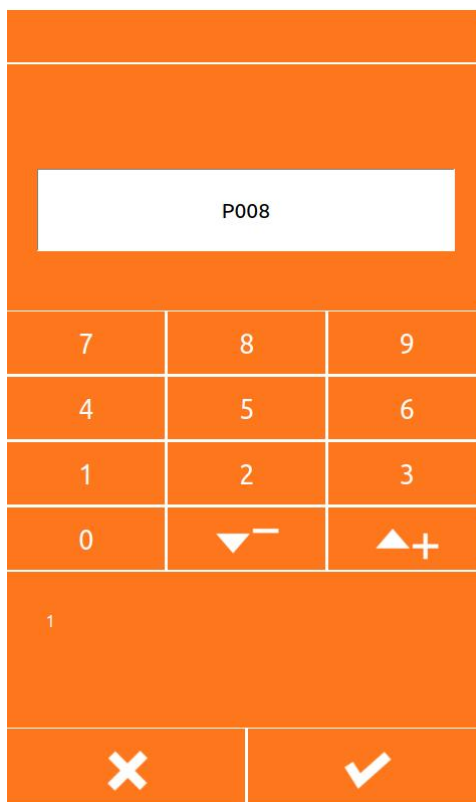

Press the following two buttons to see how many p patterns are registered. Users can register up to 255 p patterns.



: P pattern UP





: P pattern DOWN











## 2.11 Test seam operation

### ① Display Sewing Interface

In the data entry interface, after pressing the preparation key  , prepare the key into a  state, indicating the entry into the sewing interface.



### ② Display Test Seam interface

Under the sewing interface, press the key  to enter the test seam interface (as shown in the picture on the right):

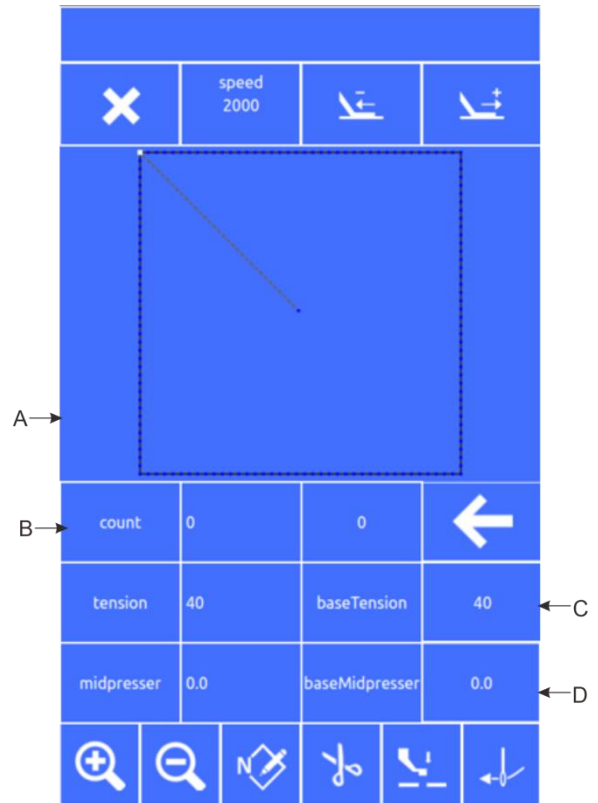
A	Pattern Display Area
B	Pattern Information Display Area
C	Tension Datum Set key
D	Medium pressure foot datum setting key
	Single-pin Back key
	Single-pin forward key
	N-pin Move key
	Cutting line key
	Threading key
	Graphic Display Zoom key
	Graphic Display Zoom out key



### ③ begins to test the seam

into the test seam interface after the foot drop, with the press foot Back button  and press the foot forward key  to determine the shape. or apply N-pin forward button  to move directly to Nth stitch.

### ④ test Seam Interface Start sewing

at the test seam interface can be in any position to trample the starting pedal directly, the machine will start sewing from the current position and return to the sewing interface.

### ⑤ ends the test seam.

After pressing the cancel key  to exit the test seam interface, return to the sewing interface, and return to the pattern starting position.

## 2.12 Counter action

### ① Display Counter Interface

In the input interface or sewing interface, positions a and B as shown in the figure are the display positions of the counter. The user can directly click buttons a and B to enter the counter setting interface.

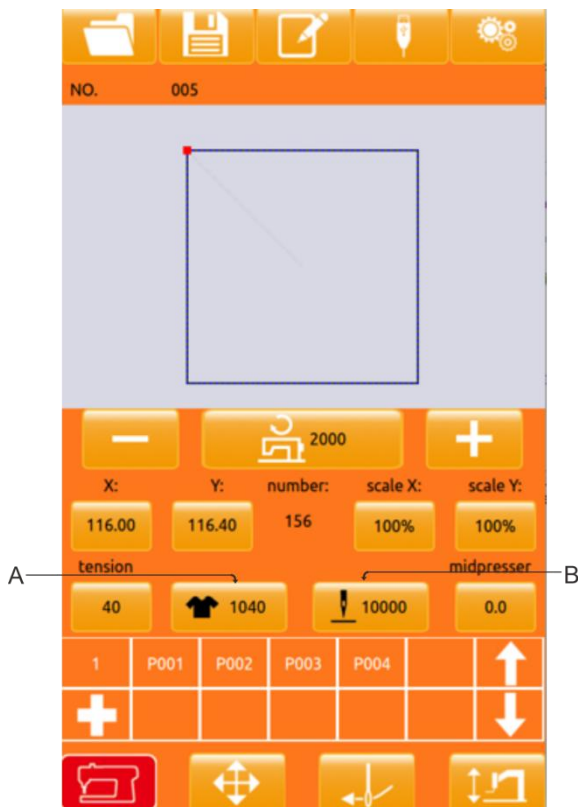

### ② Counter Clear 0 operation

The counter setting interface is shown in the figure. You can set the counter mode, current value and maximum value..

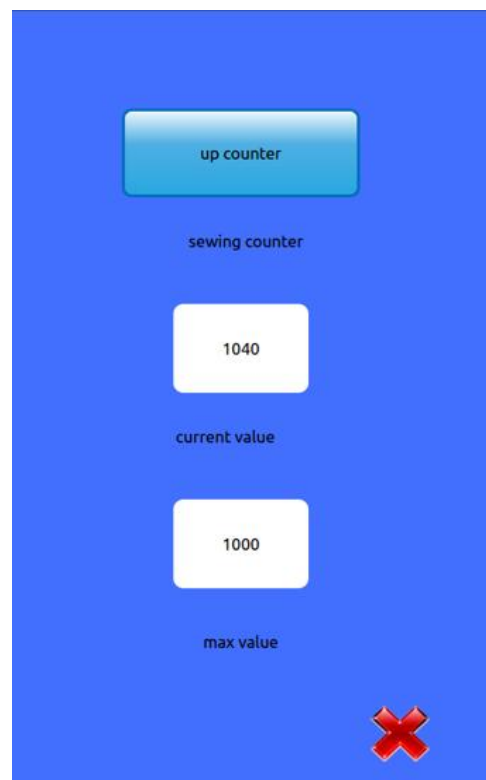

③ Set up counter actions

Click the D button in the Setup interface to enter the counter setup interface

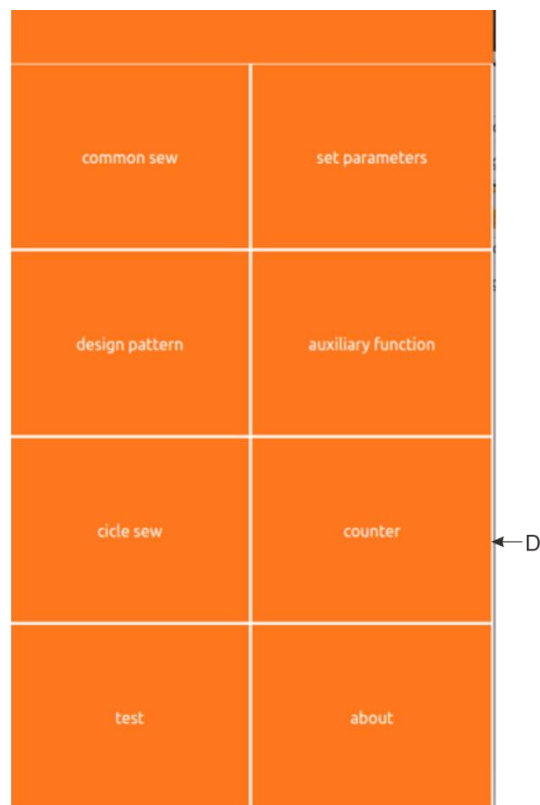

E	Sewing Counter Mode
F	Piecework Current count value
G	Sewing Counter Max
H	Needle Count counter Mode
I	Pin Count Current value
J	Needle Count counter Max

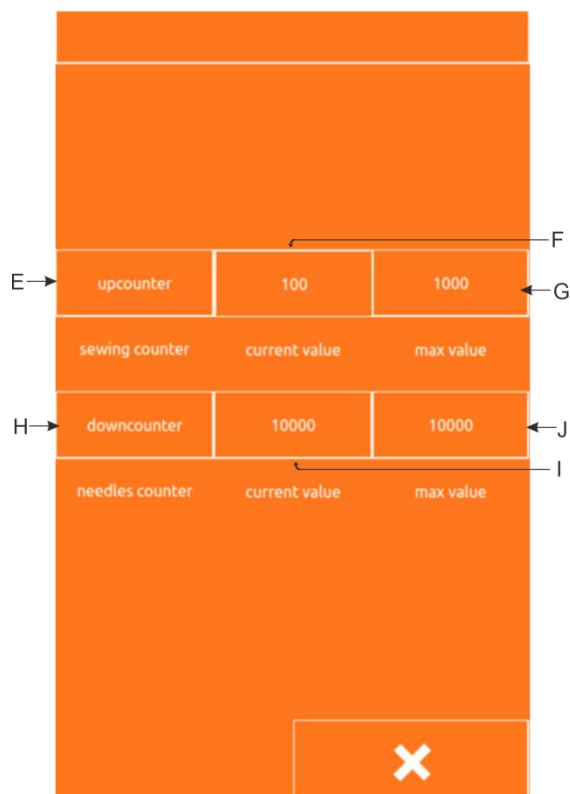

### 1. Set Counter type

Click the E or H key to enter the counter mode Setup interface, You can set the mode to "Add counter/Subtract counter/Do not use counter", after the mode setting is complete, press the key  to return to the previous interface.

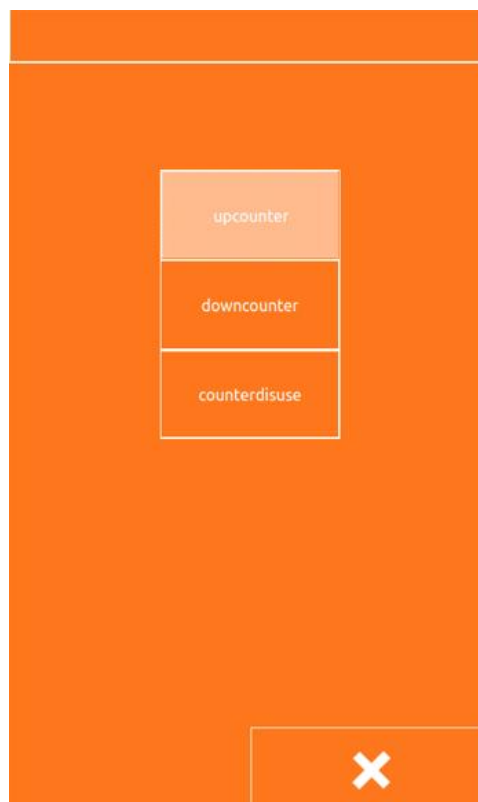

### 2. Set Count value

Click F/j or g/i, you can set the current count and maximum count values,

through the  ~  ten-letter

keyboard or ,  key input values.

**Note: The maximum number of sewing counter is 9,999, and the maximum needle count counter is 65000 stitches.**





## 2.13 Adjust the seam point operation

### ① Enter the adjusting seam point interface

In the data input interface, after adjusting the seam point button , enter the adjustment of the seam point interface. As shown on the right.

A	Analog Seam back key
B	Analog Seam forward key
C	Current number of Pins
D	Move the number of pins at a time select key
E	Adjustment data Display
F	Show Graphics Area
G	Adjust the seam point to move the keyboard
H	Lift down the press foot button

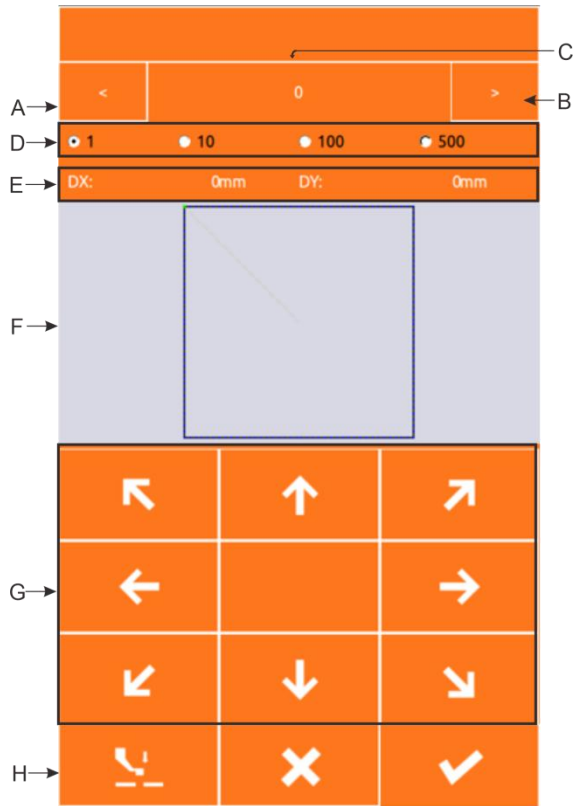

### ② Start adjusting the seam point

Move the seam point according to the mobile keyboard of the G area, so that the machine is aimed at the starting seam point of the quasi template.

After the beginning of the seam point, you can press A, B button "Analog Walk button", check whether the alignment. Analog go default one move 1 stitches, you can click the D Area radio button, select one move 10, 100 or 500 pins.

**Note: The starting point has been aligned to the standard is: machine needle and pattern sewing trajectory is not biased, if there are deviations in the description still need to**

**continue to adjust, confirm the adjustment after the key  to confirm to save the offset.**

### ③ End Test Seam

After pressing the cancel key  to exit the adjustment interface, return to the input interface.

## 2.14 Urgent stop

The emergency stop switch is pressed, press the confirmation key to enter is the sewing interface, can through the test sewing interface for needle number forward, back or cut line operation, operation steps refer to "2.11 Test sewing operation"

### 3 Quick (P) pattern operation

#### 3.1 P Pattern Data input

The quick pattern is called P pattern, which consists of a common pattern and the related pattern sewing parameters (x scaling rate, y scaling rate, speed limit, etc.). P pattern selection does not need to set the relevant parameters each time.

The P pattern data input interface is shown in the right image.

You can register up to 255 P tricks.

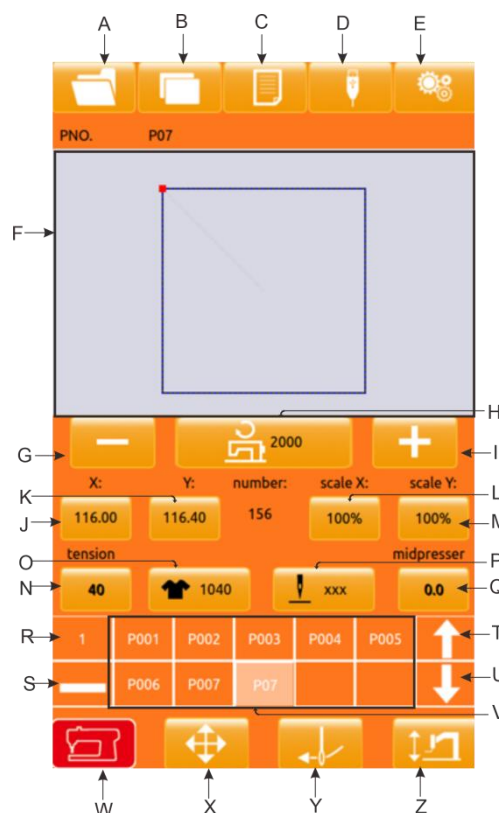

#### Function Description:

NO.	Function	Description
A	General Pattern Selection Key	Click the button to select a registered common pattern
B	P Pattern Copy button	Can copy current P-pattern content to an empty pattern number
C	P pattern editing key	Press to enter the P pattern editing interface
D	USB communication key	Press to enter the U disk communication interface
E	Set key	Press to enter the setting interface.
F	P Pattern Information Display	Display the sewing information for the current P pattern.
G	Speed down button	Reduce the sewing speed of the pattern.

H	Speed key	Set the sewing speed of the pattern.
I	Speed plus key	Increase the sewing speed of the pattern.
J	X length	Press to enter the zoom setting interface.
K	Y length	Press to enter the zoom setting interface.
L	X zoom rate	Press to enter the zoom setting interface.
M	Y zoom rate	Press to enter the zoom setting interface.
N	Tension	Show current pattern tension
O	Piece counter	Press to enter the piece counter setting interface.
P	Stitch counter	Press to enter the stitch counter setting interface.
Q	Middle presser key	Set the height of the middle presser foot.
R	P Pattern Pages	Displays the number of pages in the current p pattern, and the key switches the P pattern page numbers sequentially.
S	P Pattern Delete key	Click the button to remove the selected p pattern.
T	P pattern page UP	Click the button p to flip the page
U	P pattern page DOWN	Click the button p to flip the page
V	Registered P pattern	Press the key to switch the P pattern quickly.
W	Pattern confirmation button	Press to enter the pattern confirmation interface.
X	Move start point key	This key is invalid here.
Y	Information key	Press to enter the information query interface。
Z	Threading	Press to enter the threading state, no other operations can be performed.

### 3.2 P Pattern Editor

#### ① Enter the P-Pattern editing interface

Press the button  to enter the P-Pattern editing interface (shown on the right)

#### ② Edit Item Data Changes

Select the item you want to change, and set the value.

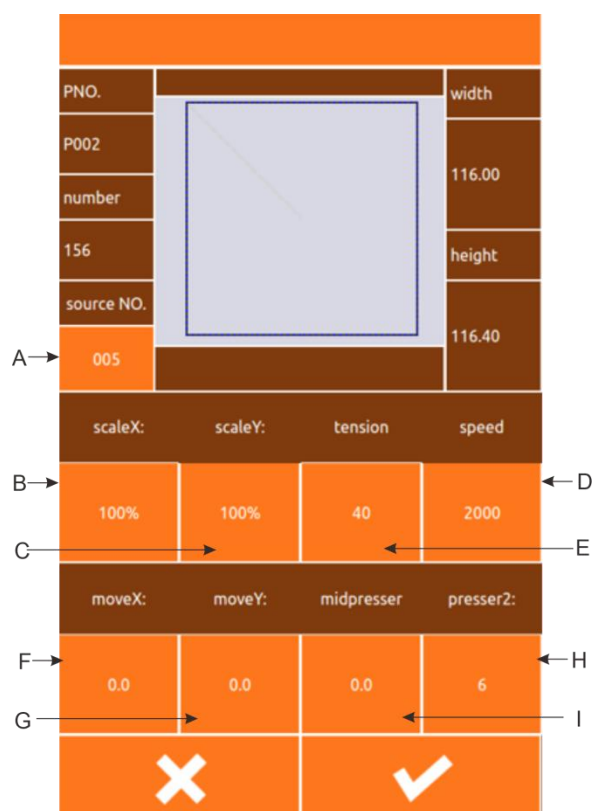

	Item	Input range	Initial value
A	Pattern original number	---	---
B	Scaling in x direction	1%~400%	100.0%
C	Scaling in Y direction	1%~400%	100.0%
D	Sewing tension	0~120	40
E	Sewing speed	400~2800rpm	2000rpm
F	X offset	-99.9~99.9	0.0mm
G	Y offset	-99.9~99.9	0.0mm
H	Medium Pressure Foot height	0.0~7.0mm	2.0mm
I	Secondary presser Foot	0~10	6mm



### ③ Determining data changes

To set the X-direction offset as an

example, pass the  ~

 ten-digit keyboard or ,

 key to input value, Press the

OK  key to complete the operation.

 : Represents positive and negative values;



### ④ Exit Edit

Press the exit key  to close the P pattern editing interface and return to the data entry interface.

## 3.3 P pattern copy



### ① Choose to be copied pattern

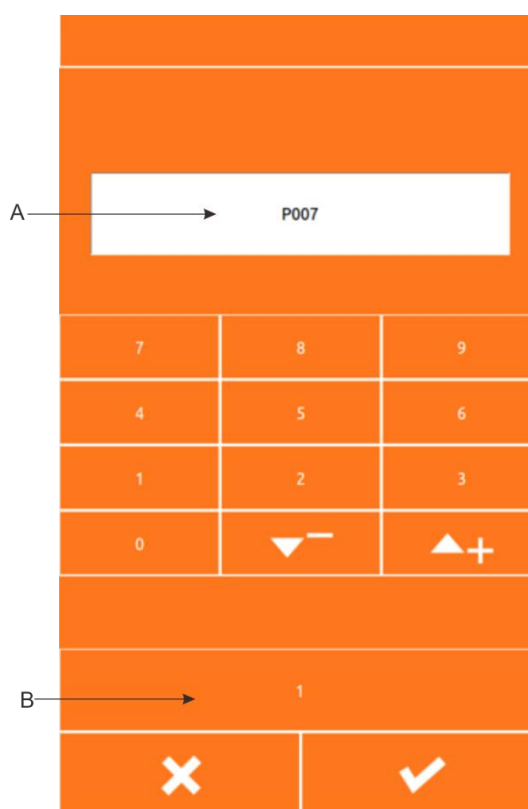

Press  Enter the P pattern copy interface (shown on the right).



② Enter new registration pattern number

A for the system automatically selected empty numbers, B is the number of pages, The user can copy the current p

pattern  to the number directly; can also through the  ~  ten-word keyboard

or   the key to enter the desired copy of the number, has been registered pattern number can not be repeated registration, the system will prompt errors.

B Key can change the number of pages, press the key  to confirm the copy, and return the P pattern input interface.

### 3.4 P Pattern Sewing

Under the P pattern data input

interface, press  to enter the sewing interface.

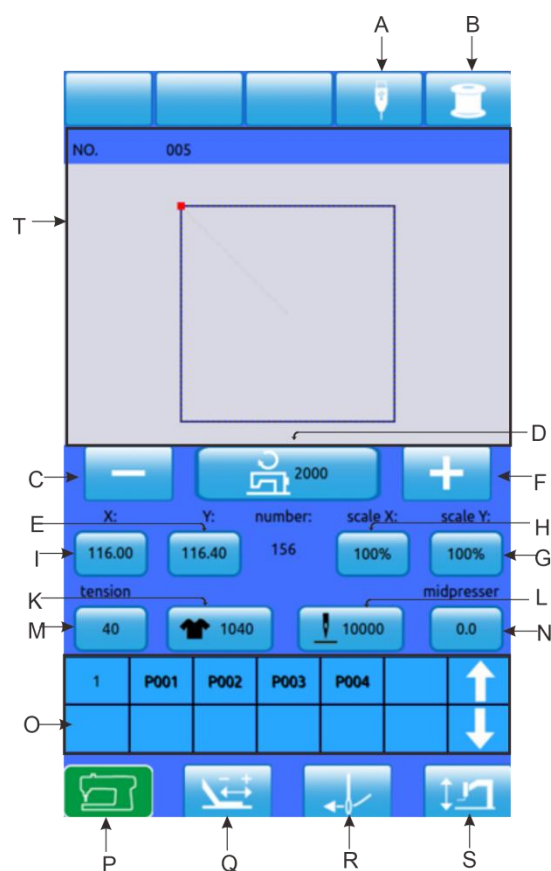

**Function Description:**

NO.	Function	Description
A	USB communication key	Press to enter the U disk communication interface
B	Winding button	Press to enter the winding interface.
C	Speed down button	Reduce the sewing speed of the pattern.
D	Speed key	Set the sewing speed of the pattern.
E	X length	Press to enter the zoom setting interface.
F	Speed plus key	Increase the sewing speed of the pattern.
G	Y zoom rate	Press to enter the zoom setting interface.
H	X zoom rate	Press to enter the zoom setting interface.
I	Y length	Press to enter the zoom setting interface.
K	Piece counter	Press to enter the piece counter setting interface.
L	Stitch counter	Press to enter the stitch counter setting interface.
M	Tension button	Press to enter the tension setting interface, you can set the sewing tension value.
N	Middle presser key	Set the height of the middle presser foot.
O	Non-operation Keys	The current state is not operational.
P	Pattern Confirmation Key	Toggle "pattern input status/sewing status".
Q	Try to sew the button	Press the button to enter the Test sewing interface to confirm the pattern stitch.
R	Information key	Press to enter the information query interface.
S	Threading Buttons	Press the button to  , Enter thread state, no other operation at this time.
T	Pattern Information Display	Displays the parameter values for the current pattern.

## 4 Combination (C) pattern operation

### 4.1 C Pattern Data Entry

Combination of the pattern for short C pattern, composed of a group of P patterns, each group C pattern can be entered up to 6 children pattern. You can register up to 50 sets of C tricks altogether.

As shown in the picture on the right.

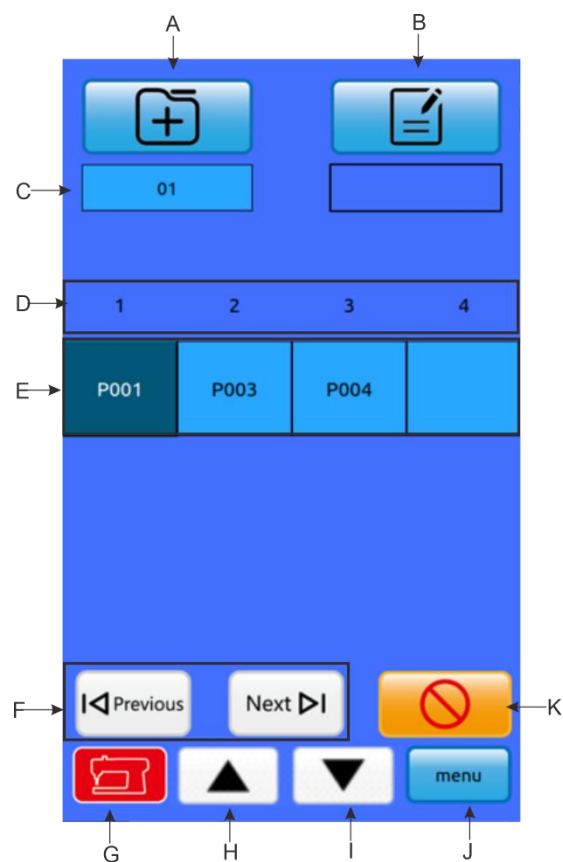



**Function description:**

<b>NO.</b>	<b>Function</b>	<b>Description</b>
A	C Pattern Registration	Register a new combination pattern.
B	Pattern naming	Enter the string you want to name
C	C Pattern Number Selection	button on the display of the current selection of the pattern number, press to enter the C pattern selection interface.
D	Sewing Order Display	Displays the sewing order of the current selection pattern,the dark color is displayed as the initial sewing pattern
E	P pattern selection	Press to enter the C pattern editing interface, where you can select and input a p pattern.
F	Current p pattern key	The dark key is the current p pattern. Press the previous and next keys to move the current p pattern.
G	Confirm Key	into the sewing state
H	Page up key	Display the P pattern of the previous page.
I	Page down key	Show next page P pattern
J	Exit key	Exit the circular sewing interface
K	Delete key	Delete the selected P pattern

## 4.2 C Pattern Editor

### ① Enter the C pattern editing interface

In the C pattern data input interface, press A to enter the C pattern editing interface. In the initial state, the P pattern was not registered as a sewing pattern, so the first pattern was displayed in a blank state.

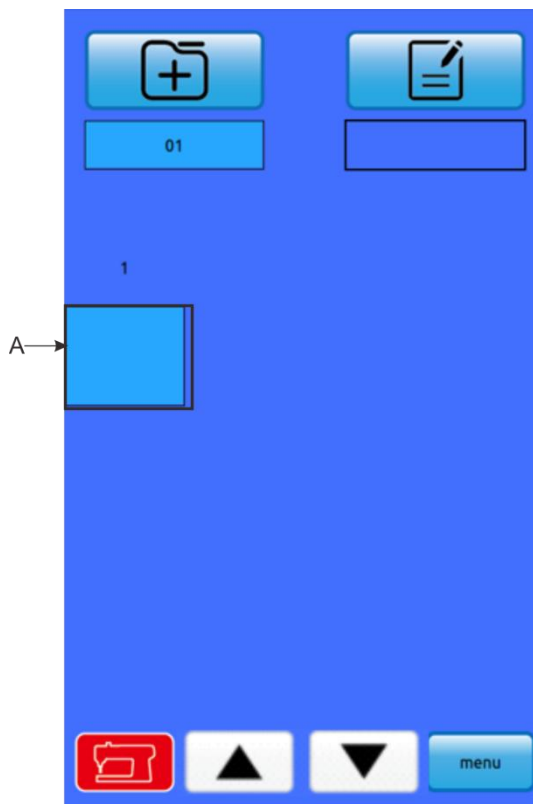

### ② Select pattern

The right picture is a C pattern editing interface, select the p pattern pattern of the B area you want to register, press the OK key  to finish the selection.

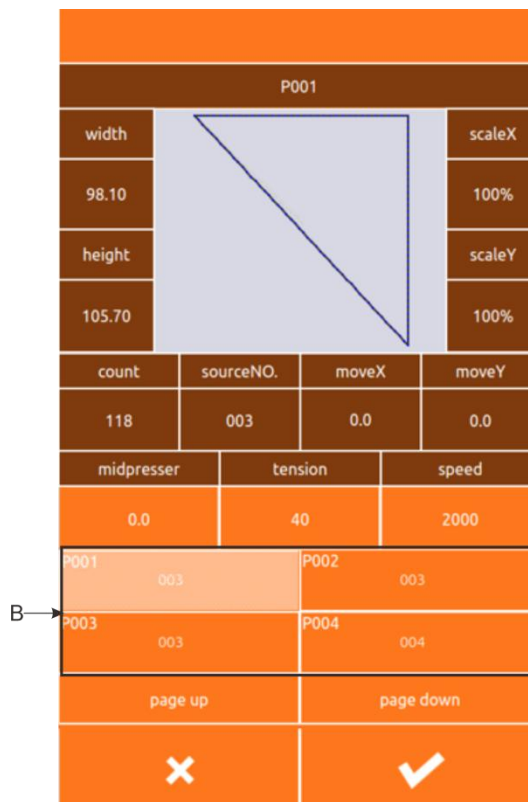

③ Repeatedly register the remaining patterns

After a pattern registration is confirmed, the next pattern selection key C is shown as above, the operation ibid, you can repeatedly register other remaining patterns.

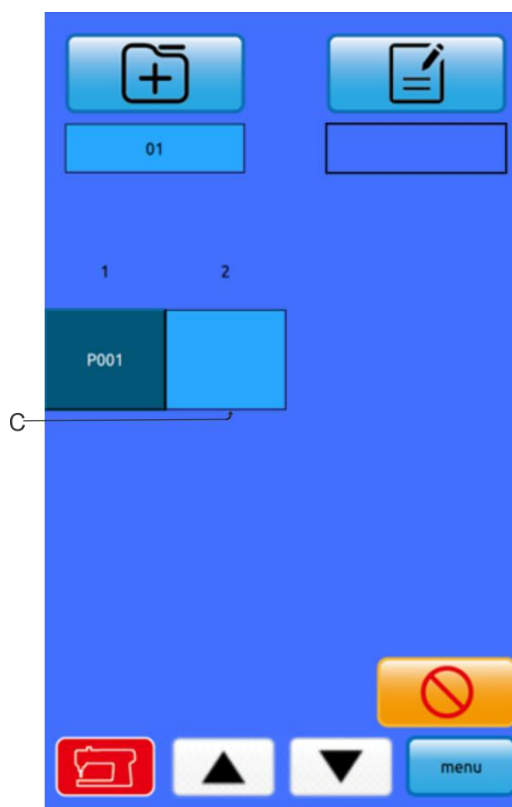

### 4.3 C Pattern Selection

① Enter the C Pattern selection interface

As shown on the right, press the icon A, you can enter the C pattern selection interface.

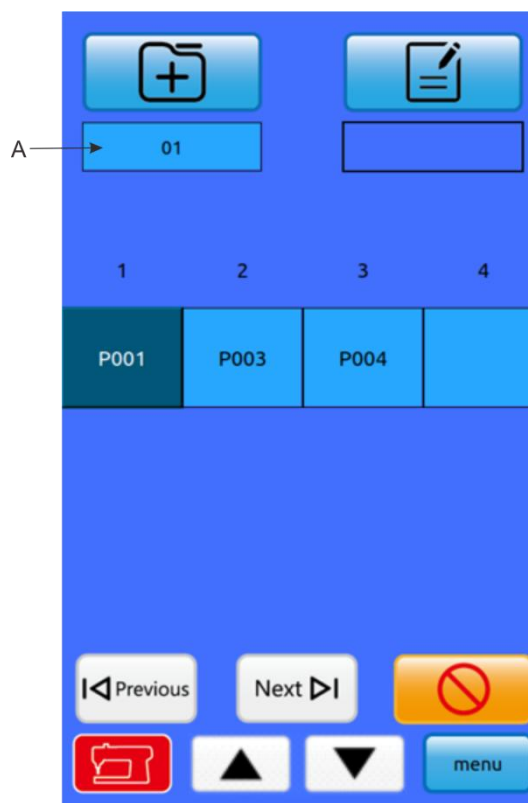

② Choose c pattern Number

The right image is a C pattern selection interface, press the B key, you can change the current C pattern of the input of the P-pattern data information. Make sure you want to select the C pattern number key C, press the OK key  to end the selection.

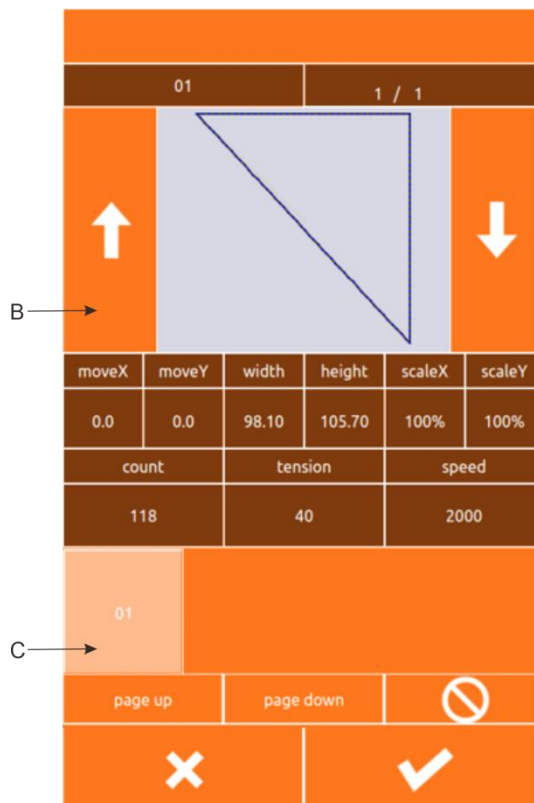

4.4 C Pattern Sewing

In the C-Pattern data entry interface, press  to enter the sewing interface (as shown in the picture on the right).

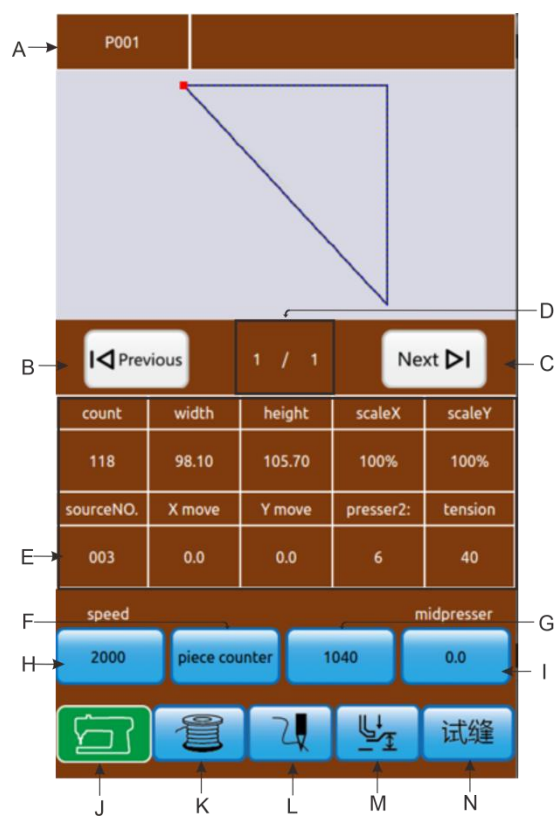

**Function Description:**

<b>NO.</b>	<b>Function</b>	<b>Description</b>
A	Sewing Shape Number Display	Displays the child pattern number registered under the current C pattern.
B	Sewing pattern Toggle Key	Switch to the previous pattern of the current sequence by pressing the sewing pattern.
C	Sewing pattern Toggle Key	Press the sewing pattern to switch to the next pattern in the current sequence.
D	Sewing Order Display	Shows the sewing sequence number in the current sewing pattern
E	Pattern Information Display	Displays parameter information for the current child pattern in the current sewing sequence.
F	Counter Mode key	Set the current count mode, "sewing count/Count of stitches".
G	Pattern Count Display	According to the setting of I, the corresponding count "number of pieces/pins" is displayed.
H	Sewing Speed Keys	Sets the sewing speed of the current sub pattern in the current sewing sequence.
I	Middle presser foot height button	Set the height of the middle presser foot of the current sub-pattern in the current sewing sequence.
J	Pattern Confirmation Key	Switch c pattern Input interface state and sewing interface state.
K	Winding button	Press to enter the winding interface.
L	Threading Buttons	After pressing it, it enters the threading state, and no other operations can be performed at this time.
M	Middle pressure foot lift down button	Can control the lifting of the foot.
N	Try to sew the button	Press to enter the Test sewing interface to confirm the current sewing sequence of the current child pattern of the needle track trend.

## 5 Pattern editing

### 5.1 Go into pattern editing mode

Press the normal sewing can switch the data input interface and mode selection interface (as shown in the right image), in this interface can be a number of detailed settings and editing operations.



Press the pattern to hit version key into the pattern editing interface.

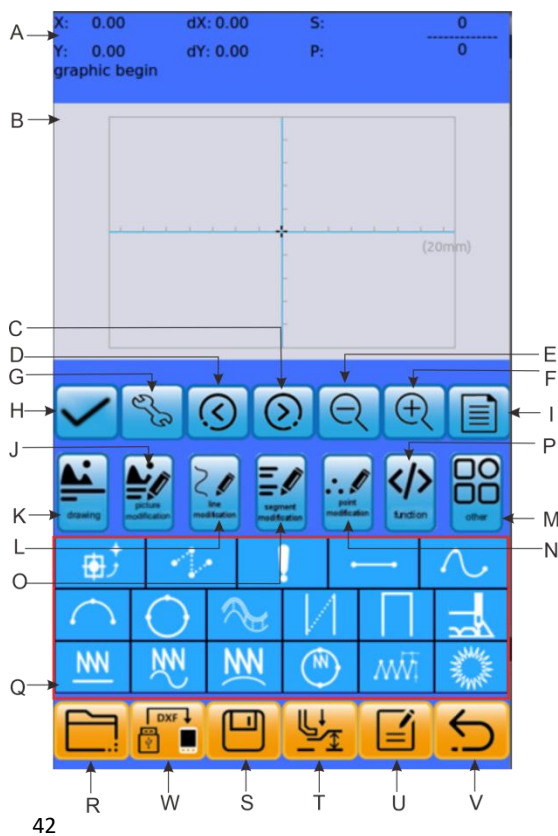

**Function Description:**

<b>No.</b>	<b>Function</b>	<b>Description</b>
A	Current PIN position status information display area	Displays the position information of the current PIN
B	Pattern Display Area	Show pattern patterns
C	Forward delivery cloth	Move the current pin position forward
D	Back to send cloth	Move the current pin position backward
E	Zoom Out	Narrow the pattern to show
F	Enlarge display	Enlarge the pattern pattern to show
G	property settings	Can set properties such as Back stitch
H	Touch the confirm button after selecting the point	The point on the pattern can be selected by touching and pressing it to confirm.
I	Feature List	Display a list of features in a print version
J	Whole map Modification	The red frame Q area shows the whole picture modification related buttons
K	Drawing	The red frame Q area shows the whole picture modification related buttons
L	Whole Line Modification	The red frame Q area shows the whole picture modification related buttons
M	function code	The red frame Q area shows the whole picture modification related buttons
N	Point modification	The red frame Q area shows the whole picture modification related buttons
O	Paragraph modification	The red frame Q area shows the whole picture modification related buttons
P	Other	The red frame Q area shows the whole picture modification related buttons
Q	Dynamic button Display Area	The red frame area is the dynamic button area
R	Open it	Open a pattern file
S	Save	Save the current display pattern as a pattern file
T	Medium Pressure Foot lift	To lift or fall in a pressed foot
U	Named	Name the pattern.
V	Exit	Exit the play version
W		

No.	Function	Description
	Secondary origin	Move the secondary origin
	Air delivery	Draw a null send
	Point seam	Draw Point Seam
	Straight seam	Draw a line
	Curved seam	Drawing curves
	Arc seam	Draw Arcs
	Circular seam	Draw a Circle
	Multiple seam	Draw multiple seams
	Double seam	Draw the same double seam
	Reverse double seam	Draw Reverse Double seam
	Straight Zigzag seam	Draw a straight zigzag seam
	Curved zigzag Seam	Draw curved Zigzag seam
	Circular zigzag seam	Draw an arc zigzag seam
	Round zigzag seam	Draw round zigzag seam
	Straight Zigzag Seam 2	Draw straight Zigzag seam 2 (multiple points per paragraph can be set)
	Jump seam	Draw Jump Seam
	template	Chrysanthemum eye and other templates



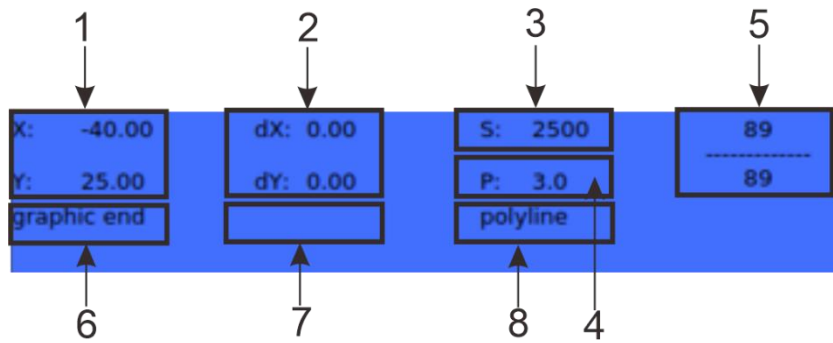

NO.	Item	Description
1	Absolute coordinates	Represents the absolute coordinates of the origin from the current position of the machine pin.
2	Relative coordinates	Represents the relative coordinates of the current position of the machine pin.
3	Speed	Represents the sewing speed or air delivery speed of the current point.
4	Interval	Represents the current factor sewing stitch length.
5	Number of needles	The numerator represents the current number of needles, and the denominator represents the total number of needles.
6	Drop needle type	Indicates the type of drop pin position.
		The beginning of a pattern means the starting position of the design.
		The middle point of a line, which means that it is a halfway point (that is, not the vertex or the segment terminal).
		A vertex that represents the vertex of a polyline.
		A segment terminal that represents the terminal position of a line.
		A pattern terminal that represents the final position of a pattern.
7、8	Type of line or function code	When sewing data, show the line type (air delivery, line seam, curved seam, etc.). function code, display the type of the function code (tangent, etc.).

### 5.2 Pattern Editors

Using the pattern editing function, enter the following pattern patterns.

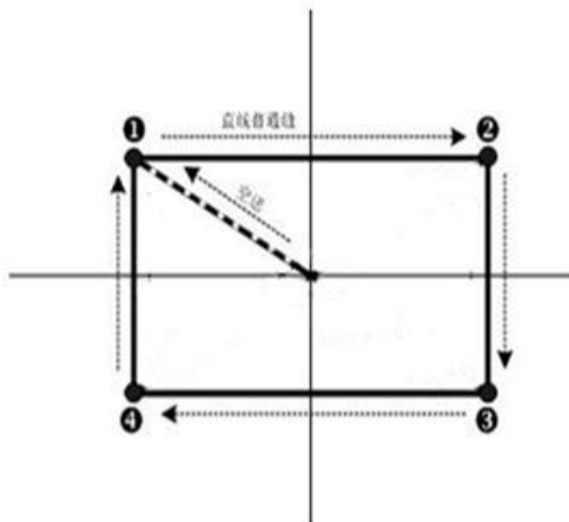

Input point:

	X (mm)	Y (mm)
1	-40.00	25.00
2	40.00	25.00
3	40.00	-25.00
4	-40.00	-25.00

Enter order: As shown in the dashed arrow in the left figure.

#### ① Air send input

In the pattern editing standard interface, press the



Air send button, Displays a null-setting interface (as shown in the image on the right).

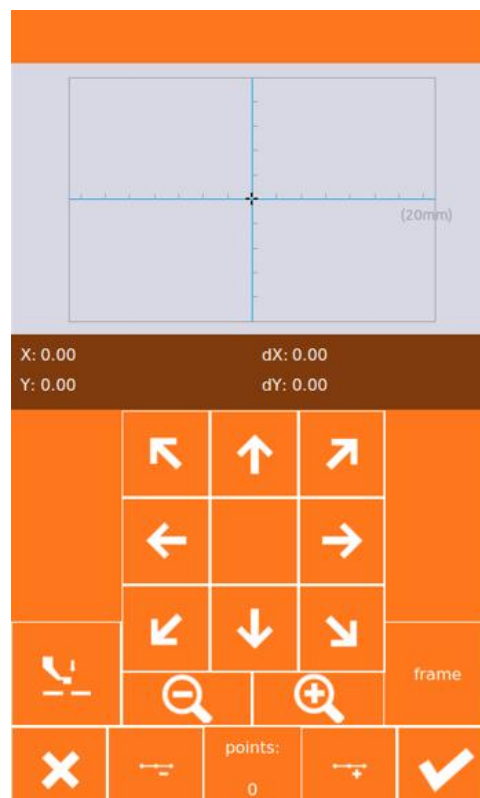

Specify the interface at the null delivery location, using the move key, moving the cursor

(pin position) to (-40,25), Press  key When you are sure, return to the pattern editing standard interface and display an empty send stitch (as shown in the right image).

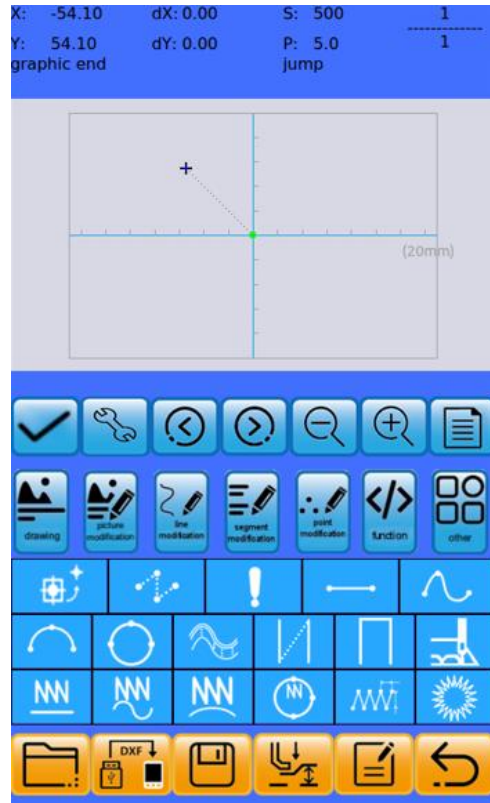

**②Input of straight line common seam**

In the pattern editing standard interface Press the straight seam key , enter the straight line common seam needle distance to set the interface, as shown in the right picture. In turn, press 3, 0 digit key, the seam trace change to "3.0", press the confirmation key to sa return to Straight line common seam setup interf

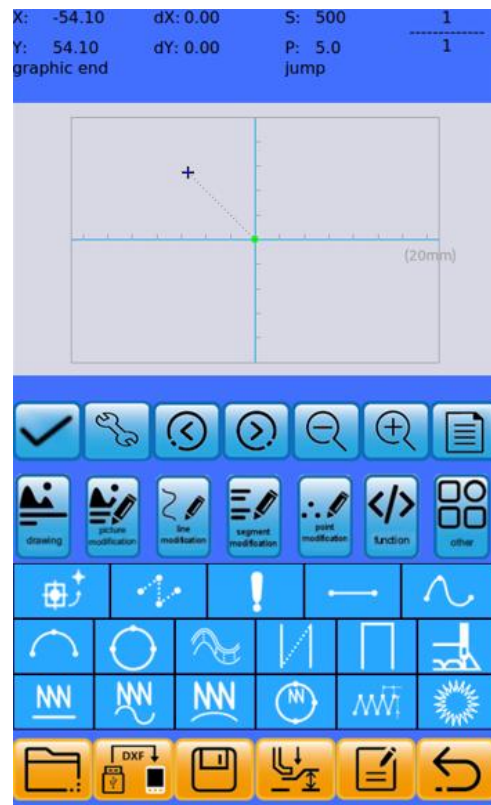

Confirm the needle distance display value is "3.0mm", press the confirmation key , enter the straight line common seam position setting interface.

Under this interface, press the move key to move the cursor (pin position) from 1 to 2, and then press the insertion point button ,

Repeat the above move, moving the cursor in the order of 1→2→3→4, as shown in the picture on the right.

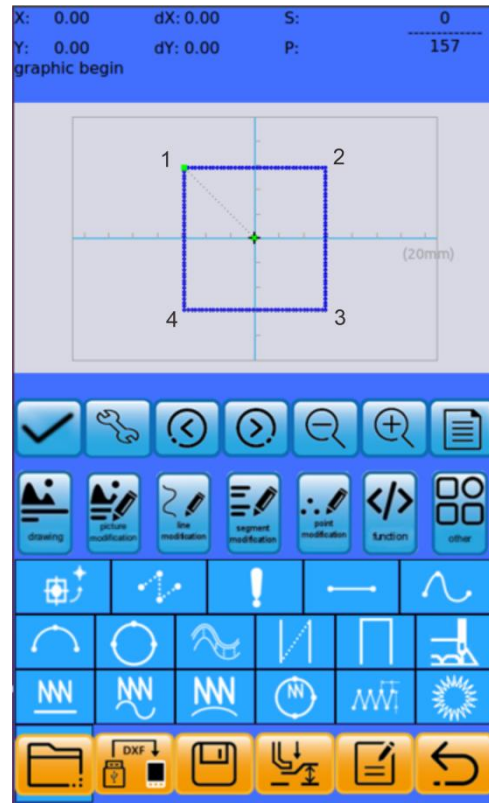

After confirming the pattern, press the  key to generate the pattern data and return to the pattern Edit standard interface, show pattern patterns.

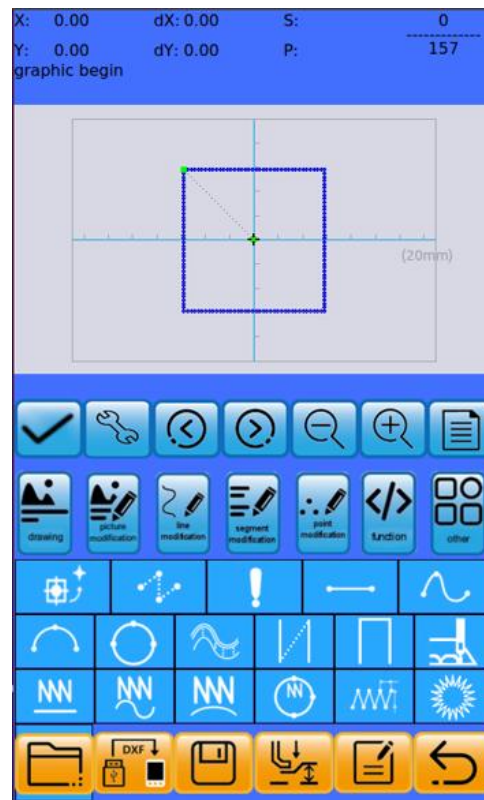

### ③ Save the pattern

Press  key, Enter the pattern to save the screen, save the edited pattern, as shown in the right picture.

The system automatically sets the sample number, and the user can enter the desired value through the numeric keypad. Press the key

 to save the pattern.

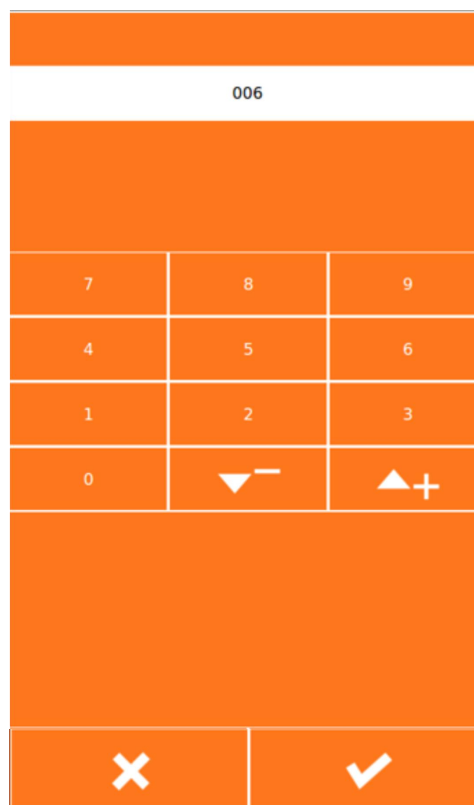

### 5.3 Change of pattern

#### 1: Drawing

- (A): Move the secondary origin
- (B): Draw a null send
- (C): Draw dotted seams
- (D): Draw a straight line
- (E): Draw a curve
- (F): Draw arc
- (G): Draw a circle
- (H): Draw multiple seams
- (I): Draw double seams in the same direction
- (J): Draw reverse double seams
- (K): Draw jump seams
- (L): Draw straight zigzag seams
- (M): Draw curved zigzag seams
- (N): Draw arc zigzag seams
- (O): Draw circle zigzag seam
- (P) : Draw straight zigzag seam 2 (each segment can set multiple points)
- (Q): Draw chrysanthemum eyes and other templates

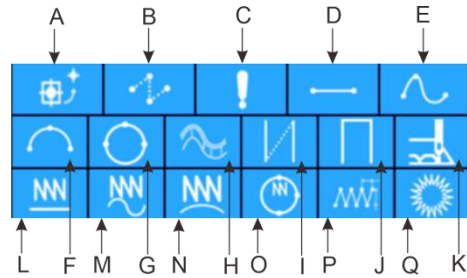

#### 2: Whole diagram Modification: Change the button dynamic button display area to display the following function button according to the whole diagram:

- (A): Move the sewing start point button
- (B): Modify the stitch length of the entire graph
- (C): Delete the entire graph
- (D): Copy the entire graph
- (E): Origin mirror
- (F):X-axis mirror image
- (G): Y-axis mirror image
- (H): Keep the original image for rotation
- (I): Delete the original image and rotate it
- (J): Keep the secondary origin, and the stitches are connected by an idle feed
- (K): The thread between the sewing threads is connected by an empty feed

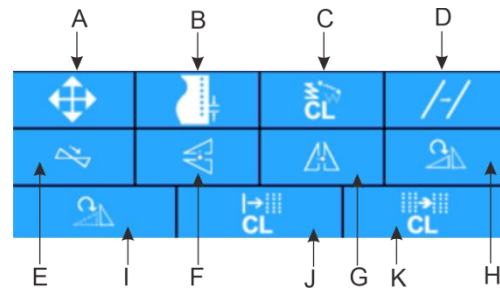

**3: Whole Line Modification button: Press the whole line to modify the button Dynamic button display area to display the following function button:**

- (A): Modify the stitch length of the current thread
- (B): Move the current line
- (C): Move multiple lines
- (D): Copy the current line
- (E): Delete the current line
- (F): Move the current line and all following lines
- (G): X-axis mirroring
- (H): Y-axis mirror image
- (I): Origin mirror
- (J): Rotate
- (K): Keep the original line for rotation
- (L): flip

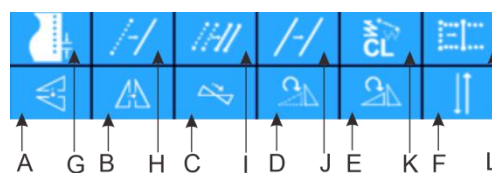

**4: Paragraph modification button: Press the button to change the dynamic button display area to display the following function button:**

- (A):Sector move
- (B):Section modification
- (C):Section deletion

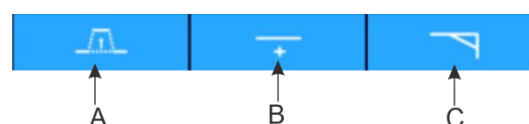

**5: Click to modify the button: Click the button to change the dynamic button display area to display the following function button:**

- (A) Move point
- (B) Add point
- (C) Delete point
- (D)

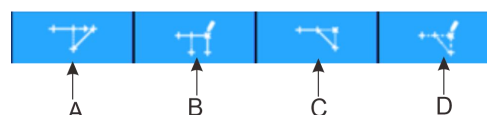

**6: Function Code button: Press the Function Code button Dynamic button display area to display the following function button:**

- (A):Cut Line
- (B): Stop Halfway
- (C):Line Tension Reference value
- (D):Base value of medium pressure foot height
- (E): Line tension
- (F):Medium Pressure Foot height
- (G):Remove feature Code
- (H): Sewing speed
- (I):Air feed speed
- (J): External input
- (K):External output
- (L):Edit function code
- (M): Side slip, flip and other dedicated extension equipment.
- (N)Pause

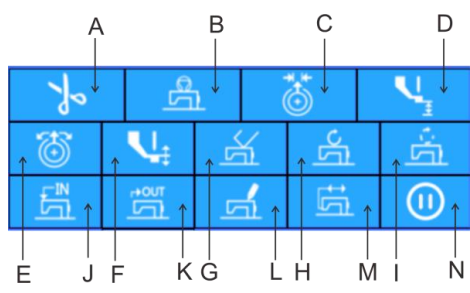

**7: Others: Press the other button the Dynamic button display area displays the following function button:**

- (A)Move to a specified pin
- (B)Replace template feature
- (C)Move empty Send
- (D)
- (E)

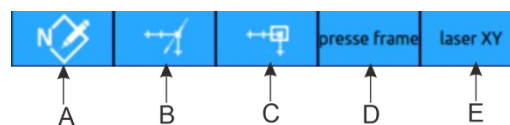



### 5.4 Exit pattern editing mode

In the pattern editing standard

interface, press  enter mode to select the interface, as

shown in the right image.



## 6 Information function

### 6.1 View version Information

#### 1 Display Information interface

In the data entry interface, the information interface is displayed after the information

button (A) as shown in the right image.



#### 2 Displays the version interface.

Press the version of the information interface and the version interface is displayed. On the version interface, you can view version information.

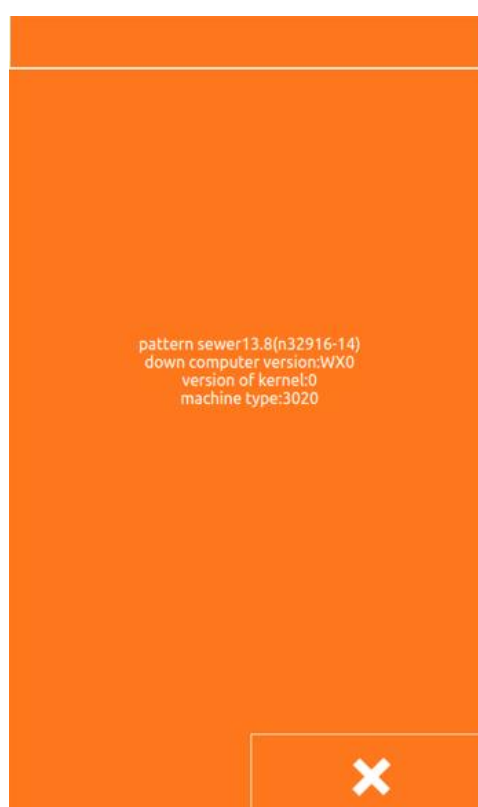
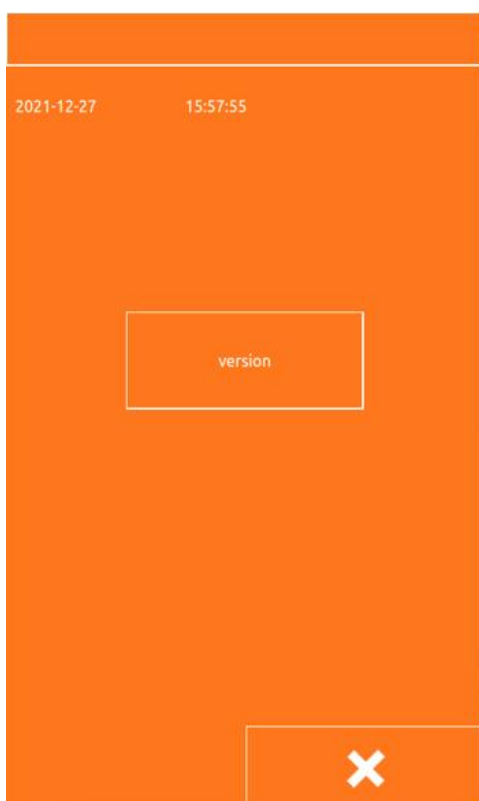



## 7 Communication function

The communication function completes the following functions:

- The sewing data compiled by other sewing machines or the software produced by the printed version will be copied to the Operation panel via U disk.
- Copy the sewing data from the operation panel to the U disk.

### 7.1 About data that can be processed

The sewing data that can be processed are as follows:

Data type	Standard format
VDT	VD00[0-9][0-9][1-9].VDT
sew	ISMS0[0-9][0-9][1-9].sew

### 7.2 Pattern transmission



#### 1. Copy the pattern file from U disk to the operation disk

In the data entry interface, press the

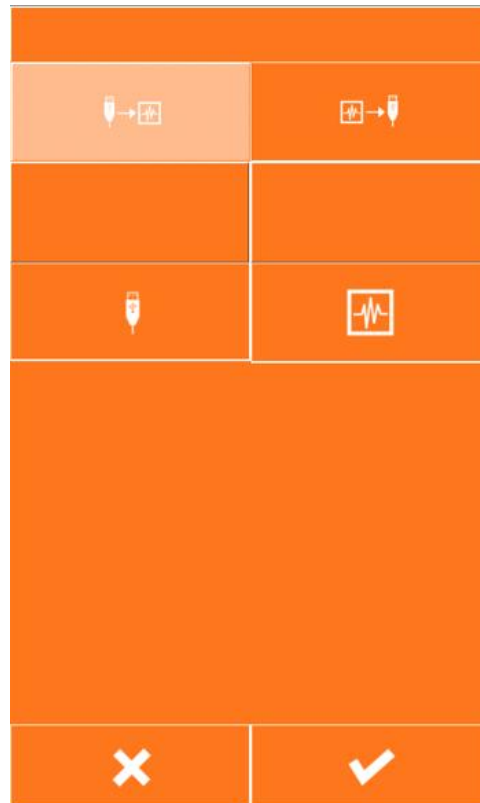

communication key , display the communication interface, as shown in the right image.

1) Select the button , this button means to copy the pattern file from U disk to the operation disk;

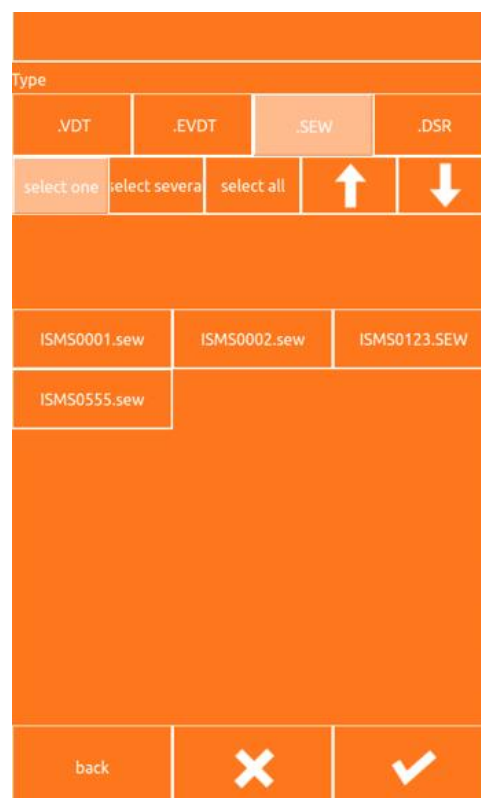

2) Press the U disk button  to display the choice of u disk file interface, as shown in the right image. Locate the file you want to copy press the OK button .



3) Press the Operation Disk button , display the input file number interface, as shown in the right image, this file number is copied to the operating disk after the file number, enter the file number later press the OK button .

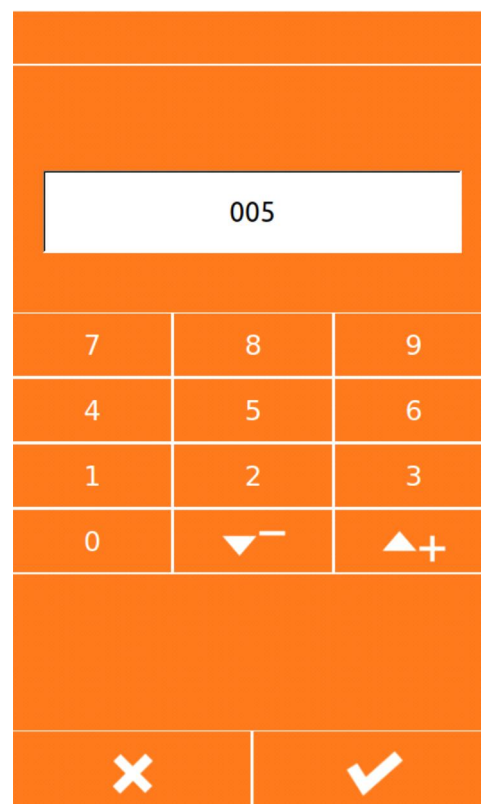

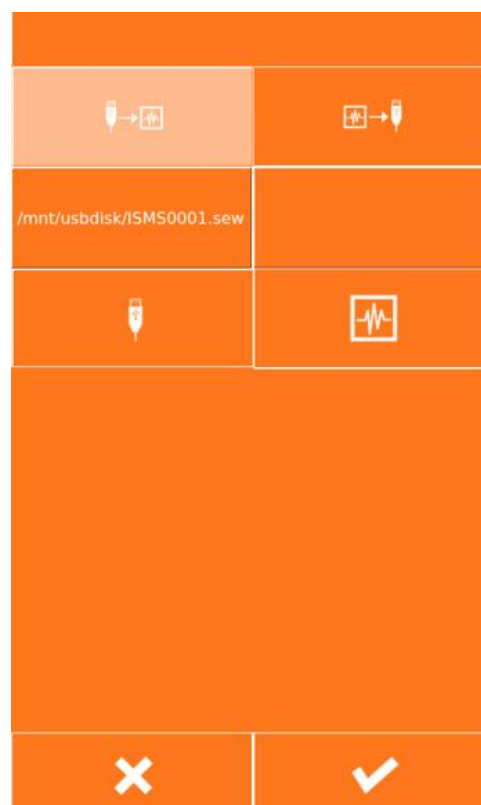

4) Select a good file from the U disk and enter the operation disk file number, as shown in the right picture, press the OK button  , so you can copy the file on the U disk to the operating disk.



**2.Save the copy file from the operation disk to the U disk**



In the data entry interface, press the

communication key  , display the communication interface, as shown in the right image.



1) Select  button, this button means copy the pattern file from the operation disk to the U disk;



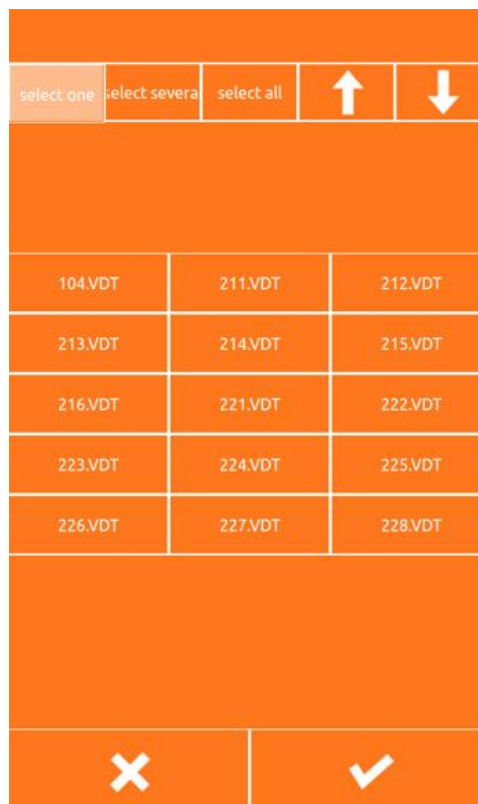

2) According to the Operation Disk

button  , display the Select operation Disk file interface, as shown in the right image. Locate the file you want to copy and press the OK button .

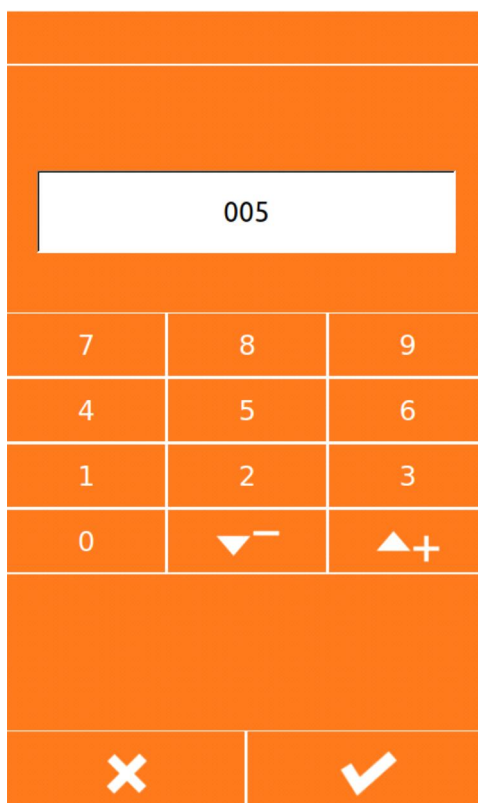

3) Press the U disk button  to display the input file number interface, as shown in the image on the right. This file number is copied to the file number after the U disk, enter the file number later press the OK button .



4) Select a good file from the operating disc and enter the file number after the U disk, as shown on the right, press the OK button , so you can copy the operation of the file to the disk.

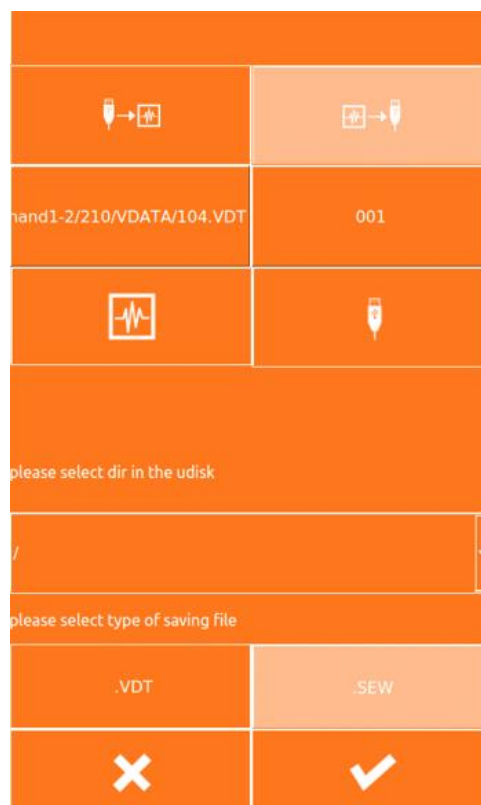



## 8 Mode and parameter settings

### 8.1 Mode switching

The ordinary sewing interface is pressed  to enter the Setup interface (as shown in the right image), where mode switching and setting can be done.

Three modes: Common seam mode, pattern playing version mode, circulation seam mode.

#### Common seam mode

Press the common seam key to enter the ordinary sewing interface, switch to the common seam mode.

#### Pattern playing version mode

According to the pattern hit version of the screen to enter the version of the interface, switch to play version mode, in the pattern of the interface can draw their own drawings, editing patterns, modify patterns and so on.

#### circulation seam mode

Press the circulation seam key to enter the circulation sewing interface, switch to the circulation mode.



## 8.2 Test

Press the test key to enter the test interface as shown in the right image.

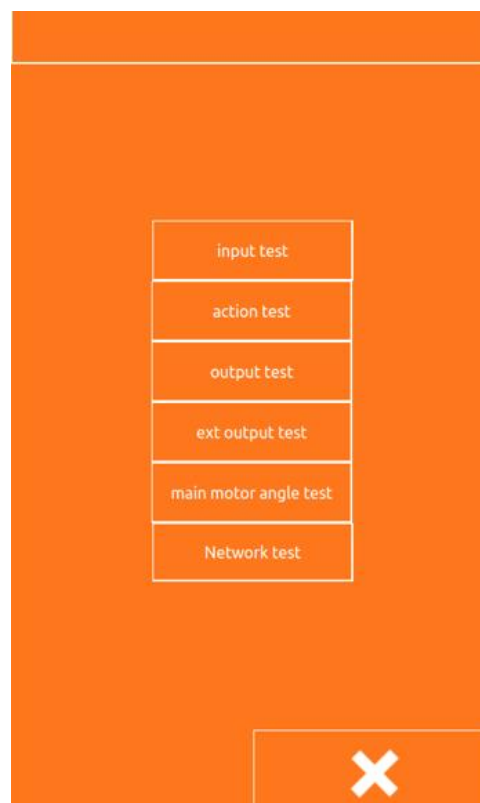

### 8.2.1 Input test

Press the input test key to enter the input test interface, as shown in the right image, you can view the X origin, Y origin, pedal switch, emergency stop switch, disconnection detection status.

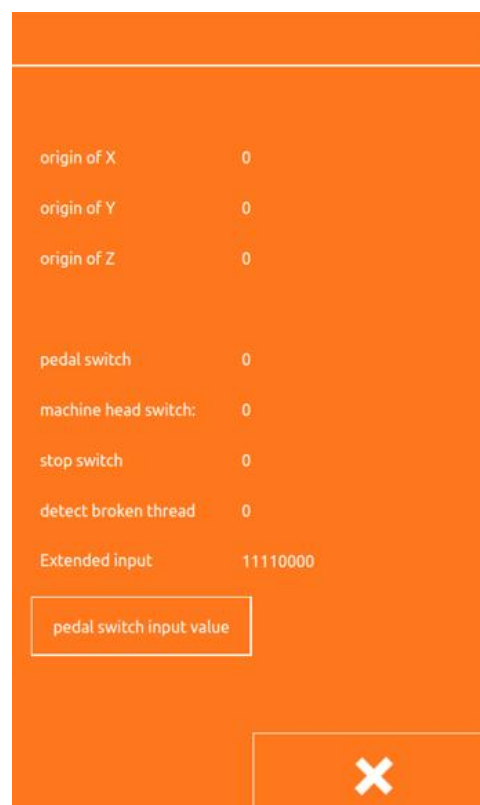

### 8.2.2 Action Test

Press the action Test key to enter the action test interface, as shown in the right image. You can test x-axis movement, y-axis movement, shear line action, medium-pressure foot action, threading action.

 : X-axis Move key

 : Y-axis Move key

 : Shear Line Key

 : Middle Press foot Key

 : Threading key

 :

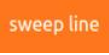
 :sweep thread key

Select the action key you want to test, then click the Plus key, minus key, if the corresponding machine parts have action to show that this action can be performed

properly, the key  to close the test.

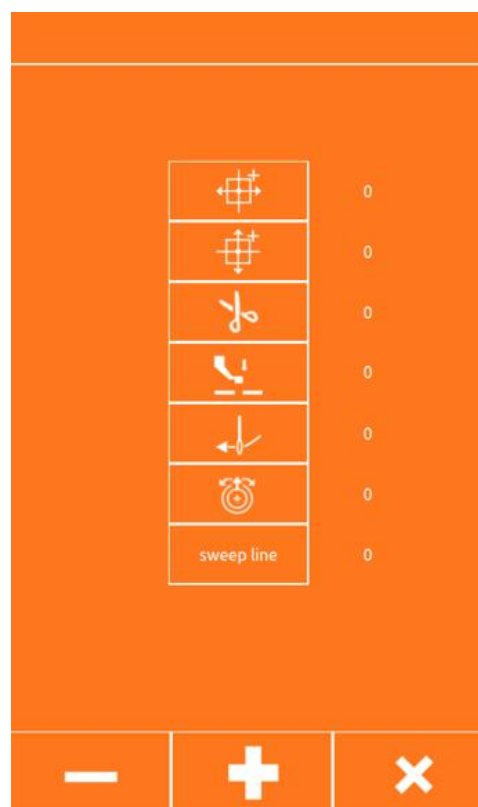

### 8.2.3 Output test

Press the output test button to enter the output test interface, as shown in the figure, press the button behind the output port, if the valve corresponding to the output port has an action, it means that the output port can work normally. After the test is completed, press the

button  to close the test.

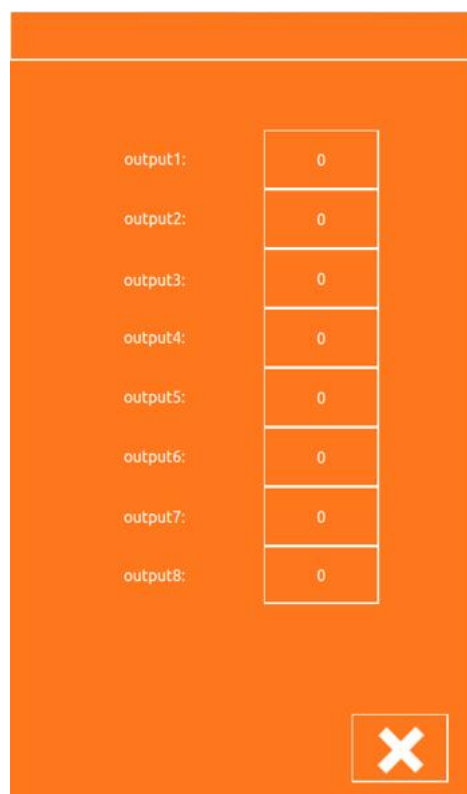

### 8.2.4 External output test

According to the external output test key into the external output test interface, as shown in the picture, the selection of external export, press Plus, minus key, if the expansion board of the corresponding external export valve has action, indicating that the external export can work, the test is completed after the

key  to close the test.

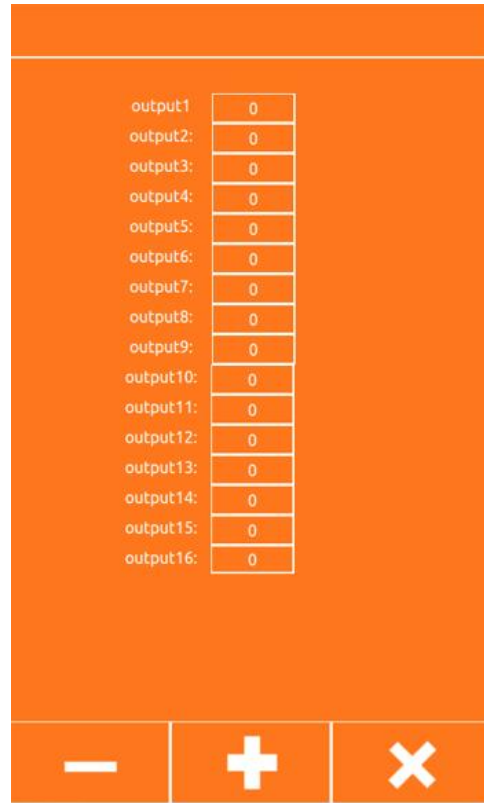

### 8.2.5 Spindle angle Test

According to the spindle angle test key into the spindle angle test interface, as shown in the following figure, you can view the current spindle angle, rotating the machine spindle, the spindle angle will change with the rotation.



### 8.2.6 Analog pedal calibration

Press the input test key to enter the input test interface, as shown in the right figure, and click key a to enter the analog pedal calibration interface.

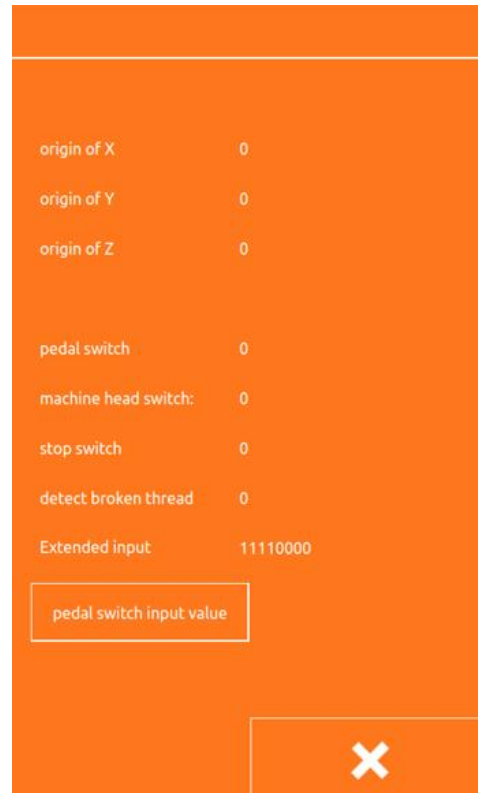

The analog pedal calibration interface is shown in the right figure

B: Current pedal depression

C: Maximum pedal depression

D: Release the balance position of the pedal

E: Maximum amount of pedal back stepping

Pedal calibration method:

1. Press button C to make it in the pressed state, step on the pedal to the maximum amount, press "✓" and save the current pedal input value;

2. Press button d to keep the key pressed, release the pedal to keep the pedal balanced, press "✓" again to save the current pedal input value;

3. Press button e to keep the key pressed, and press "✓" again to save the current pedal input value.

4. After saving the three pedal input values, the pedal calibration is completed, and press the "X" key to exit the current interface.

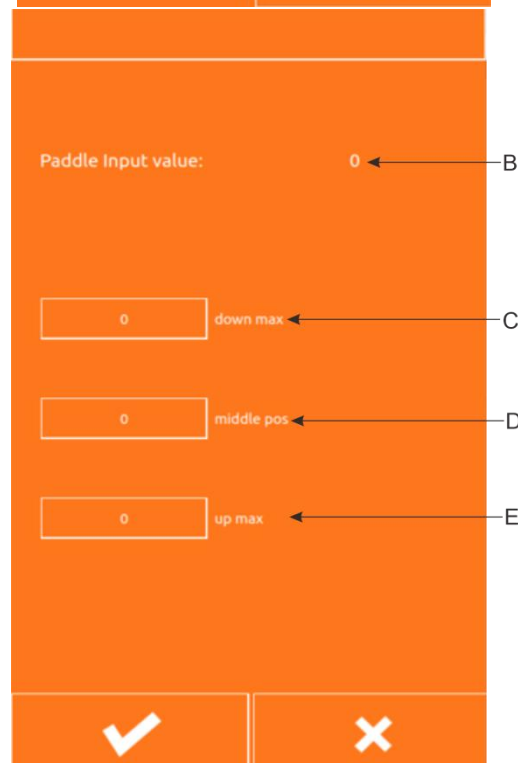

### 8.3 Parameter settings







Click on the Parameter Settings button to enter the parameter setting interface, as shown in the following figure. The main function of parameter setting is the setup of some machine parameters and the setting of some options. One of the basic settings 1 is some of the more commonly used settings related to the control Board, the basic settings in the 2 settings generally have nothing to do with the dashboard, only related to the panel, advanced settings are some of the more important settings, require the user with advanced permissions by entering a password to be set, Super settings are typically available only to factory technicians with super privileges.

The image shows a screenshot of a parameter settings interface with an orange background. It contains four main sections, each with a label and an input field:

- base set 1:** A single input field followed by an "enter" button.
- base set 2:** A single input field followed by an "enter" button.
- high set:** A "password:" label followed by an input field and an "enter" button.
- super set:** A "password:" label followed by an input field and an "enter" button.

At the bottom right of the interface, there is a large white "X" button on an orange background.

### 8.3.1 Basic Setup 1

Click on the Access button in the basic Setup 1 and go to the common basic parameter setup interface, as shown in the following figure,through  、  key to Page back and forth, select the parameter buttons you want to change, by  key, You can query the details of the selected parameters,then by  、  key, You can adjust the value of the parameter and after setting the parameter value, press  key, make sure that the changes take effect,press  key to exits the common basic parameter setup interface.



The basic setup 1 parameters are illustrated in the following table:

NO.	Set Range	Initial value	Set Unit	Set content
1	OFF/1/2	1	-	Pressure box rise time: After sewing finished, the pressure frame rises time Off: Do not automatically rise 1: In the position of the last stitch rises 2: Move to the beginning of sewing to rise
54	0~2	0	1	Drop time of intermittent presser foot: 0: Through the press foot switch linkage drop, but in the position of the drop cloth avoidance does not fall 1: Through the press foot switch linkage drop 2: The PIN switch does not linkage, sewing began to fall



2	0~8	0	1	<p>Left and right presser foot lowering action:                      0: at the same time                      1: Left --&gt; right                      2: Right --&gt; left                      3-7: reserved                      8: Grabbing --&gt; delay --&gt; pressing plate</p>
50	0~12	0	1	<p>Presser foot operating mode                      0: standard mode                      1-4: reserved                      5: Left and right presser foot → 2-stage presser foot of intermediate presser foot; When pressing the foot switch, when stepping into the first gear, it is the left and right pressers, and when stepping into the second gear, it is the sequence of the middle presser foot falling (rising at the same time)                      6-7: reserved                      8: One section electric pedal                      9-11: reserved                      12: One touch start                      Note: when it is set to one click start, if 25 items (self start) in advanced settings are turned on, And 002 (left and right presser foot lowering action) in basic setting 1 is set to 8 (plate grasping --&gt; delay --&gt; pressing plate), then it can be started automatically</p>
54	0~2	0	1	<p>Lowering time of intermittent presser foot:                      0: it descends through the linkage of presser foot switch, but it does not descend at the cloth feeding retreat position                      1: Linkage lowering through presser foot switch                      2: The presser foot switch is not linked, and it drops at the beginning of sewing</p>

70	1~2	1	1	Pedal controller Switch used 1: Pedal Controller switch (Single step) 2: Double-link pedal controller switch (optional)
71	1~2	2	1	1: The secondary presser foot is invalid 2: The secondary presser foot is effective
150	ON / OFF	OFF	-	Reverse Stitch lift Up On: The motor reverses when the upper axis stops and the needle rod returns to the top position <b>Attention] Lift the inverted stitch, because the pick rod will stop at a lower than normal position, so start sewing, pick the pole to rise.</b> Therefore, the individual sewing conditions will appear to take off the needle. OFF: Invalid
151	200~2800 (sti/min)	400	100	Sewing begins with the speed of the 1st stitch
152	200~2800 (sti/min)	800	100	Sewing begins with the speed of the 2nd stitch
153	200~2800 (sti/min)	1200	100	Sewing begins with the speed of the 3rd stitch
154	200~2800 (sti/min)	1500	100	Sewing begins with the speed of the 4th stitch
155	200~2800 (sti/min)	2000	100	Sewing begins with the speed of the 5th stitch
156	400~2800 (sti/min)	2800	100	The speed of the 5 stitches before sewing ends
157	400~2800 (sti/min)	2800	100	The speed of the 4 stitches before sewing ends
158	400~2800 (sti/min)	2800	100	The speed of the 3 stitches before sewing ends
159	400~2800 (sti/min)	2400	100	The speed of the 2 stitches before sewing ends
164	ON / OFF	OFF	-	No cutting line action On: All shear lines are not valid OFF: The sewing data, the cutting line
254	0~2	0	1	The movement route from the machine origin to the starting position 0: According to the sequence of Y axis forward → X axis center, the starting

				point moves from the XY axis at the same time 1: According to the order of Y axis forward → X axis center, the starting point moves in the order of X axis starting point → Y axis starting point 2: According to the order of X axis right end → Y axis forward, the starting point moves in the order of X axis right end → Y axis starting point → X axis starting point
462	0~2	0	1	Scaling down datum points 0: Center of Sewing border (origin) 1: Sewing Start point 2: Pattern Center Point
472	1~17	6	1	Two-stage pressure pin setting: Set the height of the two-level presser foot, the unit is mm.
552	-10~1	0	1	Thread loosening synchronization during thread trimming [8 degrees per step] -10~1 -10: Advance ← 0: Standard → 1: Delay
564	0~1	1	1	Tensioner automatic closing time 0: The tensioner is not closed 1: The tensioner is closed about 1 minute after opening
962	ON/OFF	OFF	-	Broken wire detection ON: effective OFF: invalid
963	0~1	0	1	0: Manual tensioner 1: Electronic tensioner
964	ON/OFF	OFF	-	Run automatically ON: effective OFF: invalid
965	ON/OFF	OFF	-	Manual thread clamp starts to open ON: effective OFF: invalid
966	0~2	2	1	Dialing method: 0: invalid 1: Electronic 2: Pneumatic.
992	0~1	0	1	Moving frame 0: Move to the starting point after sewing 1: Move to the specified point after sewing
996	OFF/ON	OFF	-	OFF: Electric presser foot ON: Pneumatic presser foot

1000	0~1	0	1	Special Equipment 0: invalid 1: Effective
1001	0~2	0	1	Choice of separation mode 0: Continuous separation (the separation pattern number button is invalid) 1: Continuous separation (the separation pattern number button is effective) 2: Separate separately
1002	0~1	0	1	Grab mode 0: normal mode 1: Grab does not open mode
1003	0~3	0	1	Tensioner closing time after seam initiation Range: 0-3 stitches
1004	200~500	400	100	Cutting speed Range: 200-500(sti/min) Accuracy: 100
1005	-5~20	0	1	Adjust the angle of take-up electromagnet

### 8.3.2 Basic Setup 2

#### 1. Basic Setup 2 Interface

Click on the Enter button in Basic Setup 2 to enter the basic Setup 2 interface, as shown in the figure. 2.

#### Basic Setup 2 Feature description

1) Restore Super Set password If you forget to set up your own super password, you can use the restore Super Set password as the default password.

Using this feature requires a password from us to obtain recovery privileges.

2) Time and date settings

Sets the current date and time.

3) The parameter setting of the upper computer According to the upper machine parameters to set the key to enter the host computer parameter settings interface, as shown in the following figure.

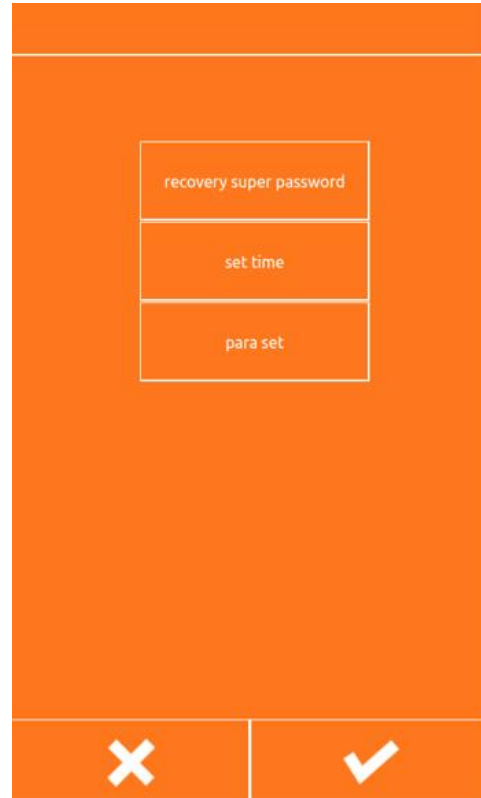

(1) Prompt tone: on: use prompt tone, off: turn off prompt tone.

(2) The prompt tone uses the default tone: on: the prompt tone uses the unified default tone, and off: the prompt tone does not use the unified default tone.

(3) Prompt tone type: select the default prompt tone type.

(4) Stitch display: on: stitch points are displayed in all States during printing; off: stitch points are displayed only during operation on stitch points during printing.

(5) Volume: adjust the prompt sound volume

(6) Stitch color on startup interface: adjust stitch color display

(7) Laser: this option needs to be turned on for machines using laser

(8) Laser range display: the laser range will be displayed in printing.

(9) Default value of delay time: function code delay time

(10) Punching: this option needs to be turned on for the punching machine

(11) Fault query: when this option is opened, the fault query button will be displayed.

(12) Sewing speed limit: turning on this option will limit the modification of sewing speed.

(13) Lock screen: when this option is turned on, the lock screen button will be displayed on the sewing interface

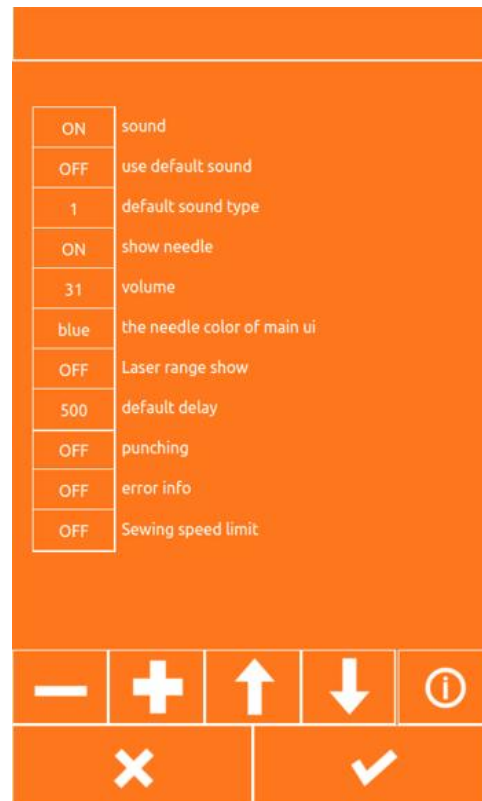

(14) Special machine: special machine needs to be selected through this option

### 8.3.3 Advanced Settings

#### 8.3.3.1 Advanced Settings Interface

Click on the blank in the back of the password to enter the password, enter the password, click the Enter button to enter the Advanced settings interface, as shown in the following figure, where the Password Settings button can change the password to enter the advanced settings, parameter settings can set some advanced parameters, PC Upgrade button can be upgraded to the panel program, Lower machine upgrade button can be upgraded to the control Board program, restore the Factory settings button can be some of the parameters of the program back to the factory settings, the original point adjustment button can be adjusted to the origin position.

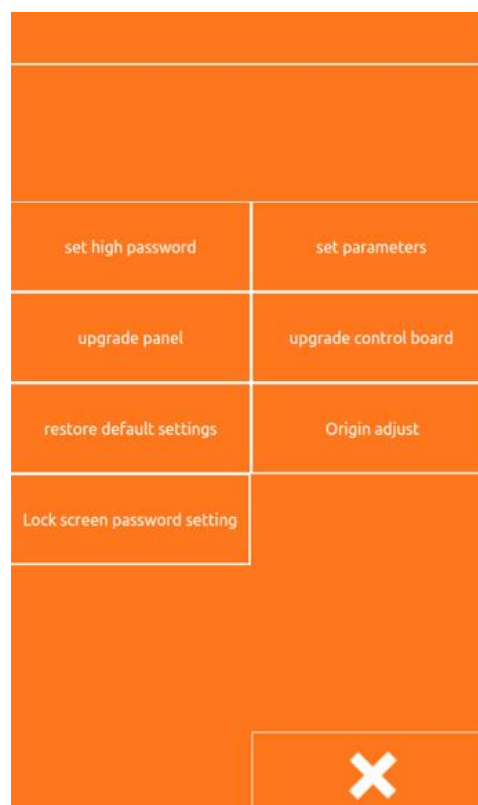

### 8.3.3.2 Advanced Settings Parameters

Click on the Parameter Settings button, you can go to the Advanced Parameters settings interface, as shown in the picture.

(002)Language choice: set in English and Chinese.

(003)Template machine status: off: Do not use the template automatic induction function; On: use template Auto sensing.

(004)Template detection: Default set to OFF, if set to on, the template to leave the template sensor machine will be an error.

(008)Template position sensor: The default setting is off, if set to on, the template left the template sensor machine does not work.

(010)Shear Line angle adjustment: Negative value in advance, positive is the delay (-60 to 30).

(011)Delivery time adjustment: Negative forward, positive is the delay (-60 to 30).

(012) relative origin X coordinate: the X coordinate of laser, cutter and other equipment relative to the origin.

(013) y coordinate relative to origin: Y coordinate of laser, cutter and other equipment relative to origin.

(016) brush speed: adjust the speed of brush, laser and other equipment.

(020) number of broken wire detection needles: set the sensitivity of the number of broken wire detection needles

(021) air feeding speed: set the air feeding speed level (1-10). The larger the value, the faster.

(023) needle stop angle adjustment: set the spindle stop angle.

(024) power on automatic online: turn this option on, and the power on automatic online will enter the pattern confirmation state.

(025) self start: this option needs to be turned on when the template is placed for automatic start

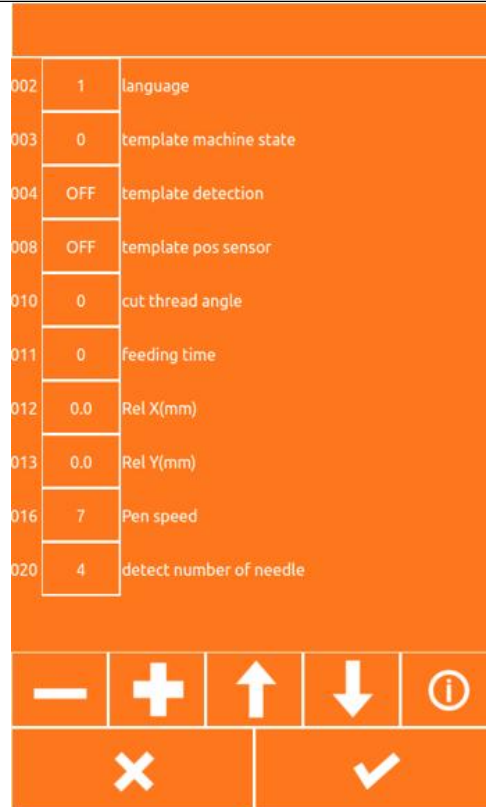

### 8.3.3.3 Upper Computer Upgrade

This procedure can through the USB disk to the host computer (panel) to upgrade, before upgrading, you need to copy the new version of the program panel file and the QM folder to the main directory of U disk, and then insert the U disk into the panel, and then through the parameters set---the Advanced settings---> host computer upgrade to the Panel program to upgrade, after the successful upgrade will appear "Successful, please reboot" prompt, reboot can be.



### 8.3.3.4 Lower computer upgrade

This program can upgrade the lower computer (control board) through USB flash disk. Before upgrading, you need to copy the nc.bin file of the new version of the program to the main directory of USB flash disk, then insert the USB flash disk into the panel, and then upgrade the control board program through parameter settings -- > advanced settings -- > computer box upgrade. After the upgrade is successful, a prompt of "success, please restart" will appear, and restart.

### 8.3.3.5 Restore factory settings

This program can restore the parameters in basic setting 1 to the default value by restoring the factory setting function.

### 8.3.3.6 Origin adjustment

Click the origin adjustment button to enter the origin adjustment interface, as shown in the figure.



### 1. Motor zero point adjustment

Press key a to enter the motor origin adjustment interface, as shown in the figure, press 1 / 2 / 3 button (keep the key pressed),

and press "   "

The key can adjust the origin position of the

X/Y/Z motor. After adjusting, click "  "

(the button is changed to the lifting state), save the current adjustment value, and click

"  " button to exit.

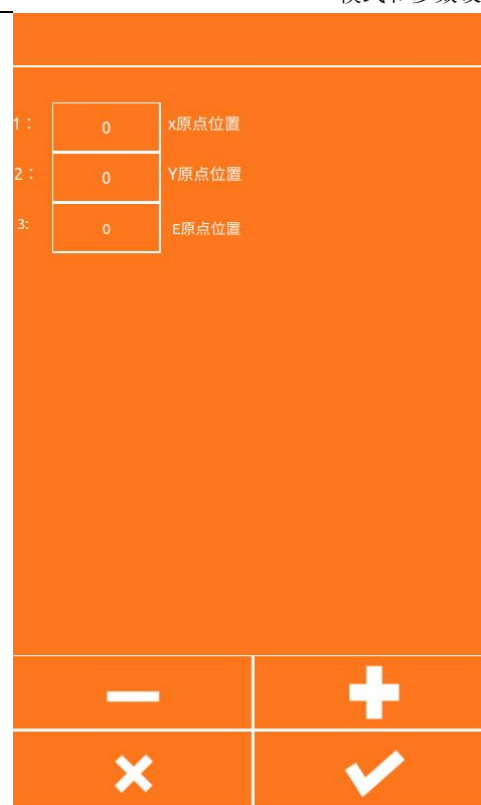

### 8.3.4 Super settings

#### 8.3.4.1 Super Settings interface

The Super settings interface, as shown in the picture, is set by the manufacturer and cannot be changed by the user. Typically, you need to set the parameters in the super settings before leaving the factory.



#### 8.3.4.2 Super Set parameters

Click the parameter setting button to enter the parameter setting interface of super parameters, as shown in the figure.

- (1) Display style: generally select the default style.
- (2) Sewing speed limit: set the maximum sewing speed. After setting, the sewing speed will not exceed this value.
- (3) X motor coefficient: pay attention to tune up before leaving factory, do not change easily after leaving factory, otherwise X direction will be inaccurate.
- (3) Y motor coefficient: pay attention to tune up before leaving factory, do not change easily after leaving factory, otherwise Y direction will be inaccurate.



### 8.3.4.3 Installment Setup

Press the installment key to enter the installment interface. To enter the installment interface, you need to enter a password to set the next step. To obtain this password, please contact the manufacturer. After entering the password, you can set the encryption. After setting the encryption, the machine cannot sew at the specified time. You need to enter the installment password to sew. Please contact the manufacturer to obtain the installment password.

## 8.4 Accessibility

Press the accessibility key to enter the accessibility interface, as shown in the figure.

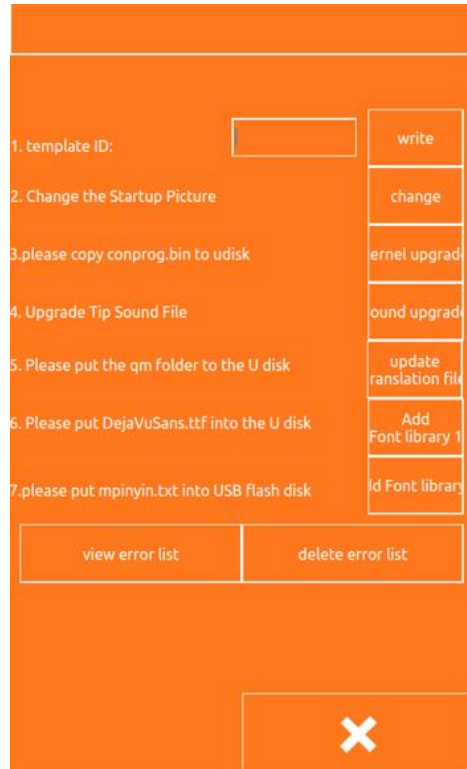

### 8.4.1. Template ID

This feature is used to define templates, and the template has a wireless identification card. Each card has an ID number, which corresponds to the P pattern number in the panel. When a new wireless identification card template is made or the template ID is changed, place the wireless identification card on the template sensor, then enter the template ID number in the Template ID edit box of the accessibility interface, and then click the "Write" button when the input is completed, and the template ID number can be written to the wireless card, and the write completion will prompt for success.

### 8.4.2. Change start-up picture

If you want to change the picture displayed when the panel is started, send us the picture you want to display. Then we will change the picture to the specified format of the file sent to you, you will be the revised picture file into a U disk, the U disk inserted into the panel, you can click the "Change" button to change the start of the picture, the completion of the change will prompt success.

### 8.4.3. Kernel upgrades

When you need to upgrade the kernel, we will provide conprog.bin files to you, you will put

this file into the U disk, the U disk inserted into the Panel, the panel to identify the USB disk after the completion, you can click the "Kernel Upgrade" button to upgrade, after the upgrade will be prompted to upgrade successfully.

### 8.4.4. Beep Upgrade

When you need to upgrade the key tone, we will provide Wxaudio folder to you, you will put this folder into the U disk, the U disk inserted into the Panel, the panel to identify the USB disk after the completion, you can click the "Beep Upgrade" button to upgrade, after the upgrade will be prompted to upgrade successfully

### 8.4.5. Beep Upgrade

When you need to upgrade the key tone, we will provide Wxaudio folder to you, you will put this folder into the U disk, the U disk inserted into the Panel, the panel to identify the USB disk after the completion, you can click the "Beep Upgrade" button to upgrade, after the upgrade will be prompted to upgrade successfully.

## 8.5 Counter

Press the Counter key to enter the counter interface, as shown in the picture on the right. You can set the mode of sewing counter and needle count counter to set the current and maximum counter values.

upcounter	100	1000
sewing counter	current value	max value
downcounter	10000	10000
needles counter	current value	max value

## 8.6 About

Click on the key to enter the copyright Information query interface, enter a password to view the copyright information.。

## 9 Appendix 1 Error Code table

In the event of a machine failure, the operator panel displays an error code.

Please follow the instructions in the following table to troubleshoot the problem.

Error Code	Description
10	Pressed the emergency stop switch. Press reset button to eliminate errors.
11	Press the pause switch. Press reset button to eliminate errors. Press the key to move the foot, you can continue sewing.
12	Press the pause switch. Press reset key to eliminate errors, the foot pedal to the 2nd gear, the original point of inspection.
15	The emergency stop switch was pressed when the power was plugged in, but the emergency stop switch was bad. Disconnect the power and confirm the plug P9 the motherboard socket.
16	Emergency stop switch Contact is bad when power is connected. Disconnect the power and confirm the plug P9 the motherboard socket.
25	When the power is plugged in, the foot pedal switch is placed on the 2nd gear. (2 pedal switch, is the start switch) cut off the power, confirm pedal switch.
35	The pedal switch is placed on the 1th gear when the power is plugged in. (2 pedal switch, is the squeeze switch) cut off the power, confirm pedal switch.
50	The head of the sewing machine was dumped when the power was plugged in. Cut off the power and lift the head of the sewing machine. Confirm the plug on the motherboard socket P14.
51	The sewing Machine Head was found to be dumped during start-up. Disconnect the power and confirm the plug P14 the motherboard socket.
55	When the power is plugged in, the head of the sewing machine is dumped. Cut off the power and lift the head of the sewing machine. Disconnect the power and confirm the plug P14 the motherboard socket.
65	When the power is connected, the key of the Operation panel is the state of press, or the contact of the key is bad. Disconnect the power and confirm the operator panel key.
100	If the "Greaseup" notification appears, do not add grease (no cleanup work is done). Add run, and then perform the cleanup work operation.
111	The parking position is not correct---cut off the power supply, confirm the shear line device or sewing machine motor is abnormal phenomenon.
121	The shear line cannot be completed. Cut off the power supply, confirm the fixed knife, moving knife blade parts whether there is scratches or damage.
130	Main Motor fault---spindle motor failure, or spindle motor controller failure.
131	The Sync monitor is poorly contacted. Cut off the power and confirm that the P11 plug is in good condition.
132	found that the main motor of the sewing machine is not normal rotation cut off the power supply, to confirm the motor motherboard plug P11 plug condition is good.
133	The sewing main motor stops in a bad position. Cut off the power and confirm that the P11 plug is in good condition.

150	The main motor of the sewing machine is abnormally heated or the temperature sensor is running poorly. Cut off the power and confirm the condition of the sewing machine. If the sewing data sewing (short cycle) of the needle number (15 stitches) is repeated, the shaft motor overheating, there is the possibility of [E150] failure. )
200	No origin found in x direction---x motor failure, or Y origin sensor failure
201	The X-pulse motor stops abnormally. Cut off the power supply to confirm that the X delivery direction is abnormal.
203	X-Motor overcurrent---x-motor failure, or X-Motor Control Panel failure
204	During the sewing process, the X-pulse motor stops abnormally. Cut off the power supply to confirm that the X delivery direction is abnormal.
205	The X-pulse motor stops abnormally during movement to the beginning of the sewing position. Cut off the power supply to confirm that the X delivery direction is abnormal.
206	The X-pulse motor stops abnormally during transmission. Cut off the power supply to confirm that the X delivery direction is abnormal.
207	Unable to detect X motor Motion---y motor failure, or X-Motor encoder failure, or X-Motor Control Panel failure
208	X-Motor out of control---x-Motor encoder failure, or X-Motor panel failure
210	Y-Direction cannot find the origin---y motor fault, or Y origin sensor failure
211	The Y-pulse motor stops abnormally. Cut off the power supply and confirm that the direction of y delivery is abnormal.
213	Y motor overcurrent---y motor failure, or Y motor Control Panel failure
214	During the sewing process, the Y-pulse motor stops abnormally. Cut off the power supply and confirm that the direction of y delivery is abnormal.
215	The Y-pulse motor stops abnormally during movement to the start position of the sewing. Cut off the power supply and confirm that the direction of y delivery is abnormal.
216	The Y-pulse motor stops abnormally during transmission. Cut off the power supply and confirm that the direction of y delivery is abnormal.
217	Unable to detect Y motor motion---y motor fault, or Y motor encoder failure, or Y motor Control Panel failure
218	Y motor out of control---y motor encoder failure, or Y motor Control Board failure
300	Shear Line motor can not find the original point---shear line motor fault, or shear line motor encoder failure
301	Unable to detect the rise and fall of the presser foot/button clamp. Cut off the power supply to confirm the pressure Foot/button folder up and down direction whether there is abnormal phenomenon.
303	Shear line motor over current---shear line motor failure, or shear line motor Control Board failure
307	Can not detect the shear line motor electrical movement---shear line motor failure, or shear line motor encoder failure, or shear line motor Control Board failure
308	Shear line motor out of control---shear line motor encoder failure, or shear line motor Control Board failure
320	The scratch motor cannot find the origin---the fault of the grasping line motor, or the

	encoder fault of the grasping line motor
321	Wire-catching motor over current---catch-line motor fault, or catch-line motor control Board failure
323	Unable to detect the scratch Line motor electrical movement---catch line motor fault, or catch line motor encoder failure, or catch the motor control Board failure
324	Scratch-line motor out of control---catch-line motor encoder fault, or catch-line motor control Board failure
400	When the power is plugged in, the connection communication error between the motherboard and the motherboard is detected. Cut off the power, confirm the electrical board motherboard socket P1 and the electrical motherboard socket P3 plug condition is good.
401	When the power is plugged in, the connection communication error between the motherboard and the motor motherboard is detected. Cut off the power supply to confirm that the motherboard socket P5 and the electrical motherboard socket P2 plug condition is good.
410	Detected communication errors between the motherboard and the motherboard of the control board. Cut off the power and plug it in again.
411	A communication error has been detected between the motherboard and the motor motherboard. Cut off the power and plug it in again.
420	The storage tool is not inserted. Press reset key to exclude errors.
421	Because the data content is incorrect, cannot be used, or there is no data. Press reset key to exclude errors. Verify that the data in the storage tool is stored in the model ordinal.
422	An error occurred while reading the storage tool information. Press reset key to exclude errors. Confirm the data in the storage tool.
424	There is not enough space in the storage tool. Press reset key to exclude errors. Use other storage tools.
425	An error occurred while writing the storage tool. Press reset key to exclude errors. Please use the specified storage tool. Verify that the write is blocked, or that there is room.
427	The design that is registered in the loop program is deleted. Press reset key to exclude errors. Re-register the loop program and add a style.
428	The style set in the program is deleted. Press reset key to exclude errors. Reset the program to add a pattern.
430	Data cannot be backed up to the motherboard. Cut off the power and reconnect to the power supply.
440	Motherboard data store exception. Cut off the power and reconnect to the power supply.
450	Unable to read the machine type selection information from the header storage device. Cut off the power supply and confirm that the plug of the power supply motor motherboard is in good condition P16.
451	Data cannot be stored in the header memory. Cut off the power and reconnect to the power supply.
452	Unable to connect to the header storage device. Cut off the power and confirm that the



	plug in the motherboard is in good condition P16.
480	Template Position Sensor exception
500	After making the expansion, the sewing data exceeds the area that can be sewn. Press reset key to exclude errors. Set the magnification or sewing area again.
502	After the enlarged setting, the data pitch exceeds the maximum pitch 12.7mm. Press reset key to exclude errors. Set the magnification again.
510	The program data has an exception. Press reset key to exclude errors. Re-read the program data from the storage tool, or the data from the program.
511	The completion code could not be entered into the program data. Press reset key to exclude errors. Redo the program data that entered the completion code, or change the sequence number of the reader.
512	exceeds the number of pins that can be used. Press reset key to exclude errors. Change the sequence number of the reader.
581	The storage Switch folder could not be read correctly. The machine is not properly copied before and after copying. (438F of data has the possibility of reading to 430F) press reset key to eliminate errors. Please read data from the same machine.
582	The version of the storage switch is inconsistent. Press reset key to exclude errors. Please read the same version of the data.
583	The version of the parameter is inconsistent. Press reset key to exclude errors. Please read the same version of the data.
600	A surface line fracture occurs. Press reset key to exclude errors. Press the Key_step_back key to move the foot, you can continue sewing.
690	The middle voltage foot motor cannot find the origin---medium voltage foot motor fault, or medium voltage foot motor Encoder fault
691	The line clamp motor stops abnormally. Confirm that the surface line allowance is too long. Cut off the power and clear the bottom of the needle board of the fly Velvet. Verify that the socket P20, P4 plugs are in good condition on the motherboard base board.
693	Medium-voltage foot motor over current---The fault of the motor, or the control panel of the middle voltage foot motor
697	Unable to detect the medium voltage foot motor electric movement---the press foot motor fault, or the medium presses the foot Motor encoder malfunction, or the medium presses the Foot motor Control Board breakdown
698	Medium Voltage foot motor out of control---medium voltage foot motor encoder fault, or medium voltage foot motor control Board failure
700	The power supply voltage rises abnormally. Cut off the power and confirm the input voltage.
701	The main motor drive voltage of the sewing machine is abnormally rising. Cut off the power and confirm the voltage
705	The power supply voltage drops abnormally. Cut off the power and confirm the input voltage.
710	The main sewing motor detected abnormal current. Disconnect the power supply and confirm that the sewing machine is abnormal.
711	The abnormal current is detected by the Pulse motor. Cut off the power supply to

	confirm the operation of the presser foot/button clamp is abnormal.
720	The nose can't drop.
721	The nose can't rise.
820	Pattern Queue Empty
821	Pattern No end code
822	Pattern No parking code
830	Pattern Data Overflow
850	CAN Bus answer Error
901	X Motor Pulse error (internal error)
902	Y Motor Pulse error (internal error)
903	Cut line motor pulse error (internal error)
904	Pulse error (internal error) of medium voltage foot motor
905	Impulse error (internal error) of the scratching line motor
906	Internal Error
911	Internal Error
912	Internal Error
913	Internal Error
914	Internal Error