

1. 机壳分组件/Machine frame&miscellaneous cover components

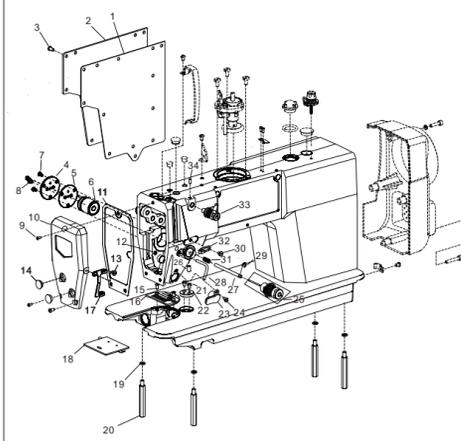

序号 Ref.No.	物料号 Part.No.	名称	Description	数量 Qty	备注 Remark
1	29.07.005	后窗板垫	Side plate gasket	1	
2	29.07.003	后窗板	Side plate	1	
3	02.09.033	螺钉	Screw	10	
4	XXXXXX	电磁铁固定板	Fixed Plate	1	
5	XXXXXX	电磁铁固定板垫	Fixed Plate gasket	1	
6	XXXXXX	松线电磁铁部件	Electromagnets	1	
7	XXXXXX	螺钉	Screw	3	
8	XXXXXX	螺钉	Screw	1	
9	02.09.013	螺钉	Screw	3	
10	29.07.064	面板	Face plate	1	
11	29.07.004	面板垫	Face plate gasket	1	
12	29.01.204-1	六角螺母	Nut	1	
13	02.09.010	螺钉	Screw	1	
14	02.05.016	面板塞	Rubber plug	2	
15	02.09.026	螺钉	Screw	2	
16	29.01.114	针板	Needle plate	1	
17	05.01.028	针板	Needle plate	1	H
18	29.07.011	左线钩	Arm thread guide left	1	
19	02.06.001	推板部件	Side plate ASM.	1	
20	23.302	弹簧垫圈	Washer	4	
21	01.01.001	底板支柱	Bed screw stud	4	
22	02.09.035	螺钉	Screw	2	
23	29.07.056H	卷边器	Ruler plate	1	
24	11.05.099	螺钉	Screw	1	
25	02.02.021BZ	夹线器部件	Thread take-up device	1	
26	02.02.012BZ	夹线器部件	Thread take-up device	1	H
27	02.09.035	螺钉	Screw	1	
28	29.01.204	侧板钩	Side plate gasket	1	
29	23.300	开口挡圈	Snap ring	1	
30	02.09.010	螺钉	Screw	1	
31	29.01.199	松线辅助弹簧	Spring	1	
32	02.07.012	右线钩	Arm thread guide right	1	
33	29.01.053BZ	上夹线器	Thread take-up device	1	
34	29.02.108	螺钉	Screw	1	

1. 机壳分组件/Machine frame&miscellaneous cover components

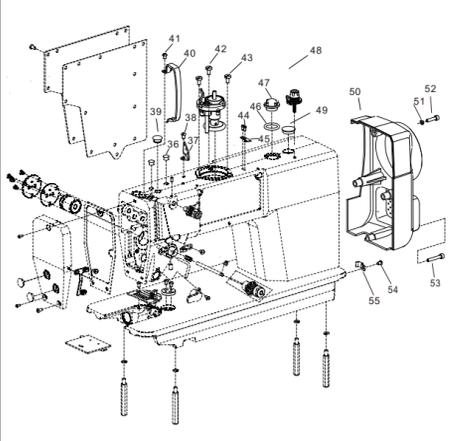

序号 Ref.No.	物料号 Part.No.	名称	Description	数量 Qty	备注 Remark
35	02.05.017	橡胶塞	Rubber plug	1	
36	02.01.179	三股过线板	Thread tension guide	1	
37	29.07.063	螺钉	Screw	1	
38	02.09.067	螺钉	Screw	1	
39	02.05.013	橡胶塞	Rubber plug	1	
40	29.07.084	挑线杆护套	Thread take-up lever cover	1	
41	02.09.007	螺钉	Screw	1	
42	29.02.005	螺钉	Screw	3	
43	29.07.082	挑线器部件	Bobbin wider ASM.	1	
44	29.02.096	螺钉	Screw	2	
45	29.01.017	挑线杆	Thread cutter	1	
46	02.05.005	O形圈	O-ring	1	
47	02.05.006	油窗	Oil window	1	
48	29.01.053BZ	挑线夹线器部件	Thread take-up device	1	
49	29.01.109	橡胶塞	Rubber plug	1	
50	30.01.096	电机罩壳	Cover Piece	1	
51	0000	垫圈	Washer	3	
52	29.02.097	螺钉	Screw	3	
53	0000	螺钉	Screw	1	
54	02.09.007	推板部件	Side plate ASM.	1	
55	05.05.016	电线夹	Cable clip	1	

2. 上轴、挑线分组件/Main shaft&thread take-up components

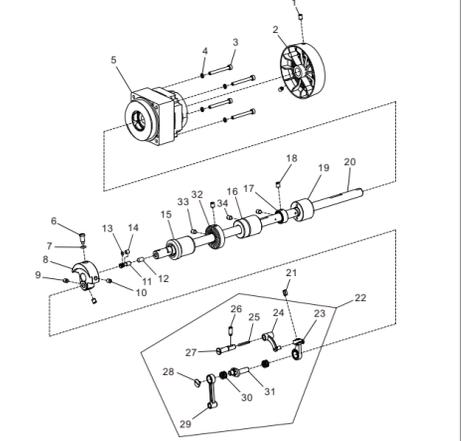

序号 Ref.No.	物料号 Part.No.	名称	Description	数量 Qty	备注 Remark
1	29.02.103	螺钉	Screw	2	
2	29.07.083	上轮	Head wheel	2	
3	29.07.067	螺钉	Screw	1	
4	23.303	弹簧垫圈	washer	4	
5	30.01.094	上轴电机	Motor	1	
6	02.09.004	螺钉	Screw	1	
7	01.03.012	O形圈	O-ring	1	
8	29.01.151	针杆曲柄	Counter weight	1	
9	01.04.011	针杆	Needle bar	1	
10	02.09.003	螺钉	Screw	1	
11	02.07.013	曲柄油窗 销	Adjusting pin	1	
12	23.81	曲柄油窗限制毡	Felt	1	
13	02.05.018	O形圈	O-ring	1	
14	02.07.014	曲柄油窗量 销套	Sleeve of adjusting pin	1	
15	29.07.076	上轴前轴套	Bearing support	1	
16	29.01.029	上轴中轴套	Bearing support	1	
17	29.07.019	上轴轴套	Thrust collar	1	
18	01.10.039	螺钉	Screw	2	
19	29.04.040	上轴后轴套	Bearing support	1	
20	29.07.051	上轴	Main shaft	1	
21	02.07.029	挑线杆防油套	Oil resistant cover	4	
22	02.04.015	挑线杆部件	Thread take-up lever Asm.	1	
23	02.04.015H	挑线杆部件	Thread take-up lever Asm.	1	H
24	02.04.019	挑线杆	Thread take-up lever	1	H
25	02.04.018	挑线杆	Thread take-up bar	1	
26	23.76	油线	Oil thread	1	
27	02.09.005	螺钉	Screw	1	
28	02.04.020	挑线杆轴套	Thread take-up crank shaft	1	
29	02.04.021	螺钉	Screw	1	
30	01.04.030	滚针轴承	Bearing	2	
31	02.04.016	挑线曲柄	Needle bar crank	1	
32	02.04.016H	挑线曲柄	Needle bar crank	1	H
33	29.04.014	主动轮	Wheel	1	
34	29.02.039	螺	Screw	2	
35	01.10.040	螺	Screw	2	

3. 针杆、勾线分组件/Needle bar&Hook of driving shaft components

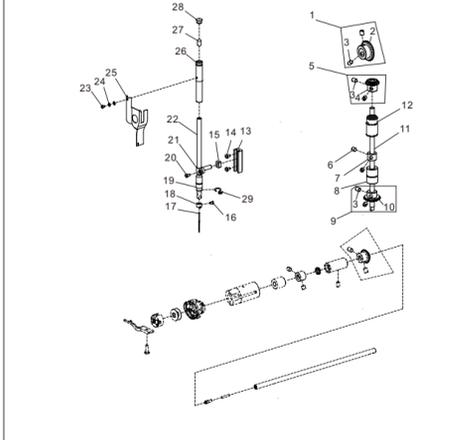

序号 Ref.No.	物料号 Part.No.	名称	Description	数量 Qty	备注 Remark
1	29.01.190	上轴伞齿轮部件	Gear	1	
2	29.01.190-1	上轴伞齿轮	Gear	1	
3	29.01.190-2	螺钉	Screw	8	
4	29.01.189-1	变速箱上伞齿轮部件	Gear	1	
5	29.01.189	变速箱上伞齿轮	Gear	1	
6	01.10.039	螺钉	Screw	2	
7	29.07.020	挡圈	Thrust collar	1	
8	29.01.034	变速箱下轴套	Bearing support	1	
9	29.01.191	变速箱下伞齿轮部件	Gear	1	
10	29.01.191-1	变速箱下伞齿轮	Gear	1	
11	02.03.002	变速箱	Upright shaft	1	
12	29.01.038	变速箱上轴套	Bearing support	1	
13	02.04.014	滑块槽	Slide rail	1	
14	02.09.034	螺钉	Screw	2	
15	02.04.004	针杆连接柱滑块	Slider	1	
16	01.10.006	螺钉	Screw	1	
17	01.04.029	DBx1.14#机针	Needle DBx1.14#	1	
18	29.01.200	DPx5.18#机针	Needle DPx5.18#	1	H
19	02.04.011	针杆线钩	Needle bar thread guide	1	
20	02.01.011	针杆下轴套	Bearing support	1	
21	02.01.020	针杆下轴套	Bearing support	1	H
22	02.04.017-2	螺钉	Screw	1	
23	02.04.017	针杆连接柱	Needle bar holder	1	
24	02.04.008	针杆	Needle bar	1	
25	02.04.008H	针杆	Needle bar	1	H
26	02.09.037	螺钉	Screw	1	
27	23.309	垫圈	Washer	2	
28	02.05.020	面部防油板	Oil stopper	1	
29	02.04.012	面部上轴套	Bearing support	1	
30	0000	毛毡	Wool felt	1	
31	02.05.014	橡胶塞	Rubber plug	1	
32	02.04.007	针杆下轴套线钩	Needle bar thread guide	1	

3. 针杆、勾线分组件/Needle bar&Hook of driving shaft components

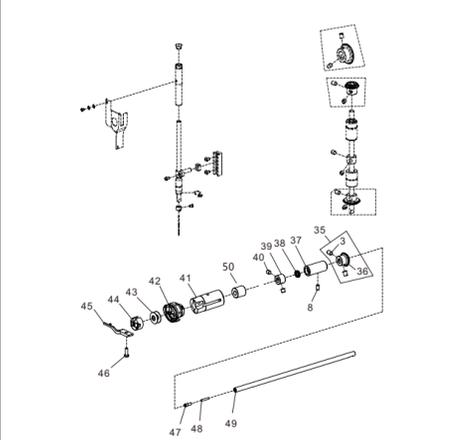

序号 Ref.No.	物料号 Part.No.	名称	Description	数量 Qty	备注 Remark
35	29.01.192	下轴伞齿轮部件	Gear	1	
36	29.01.192-1	下轴伞齿轮	Gear	1	
37	29.07.024	下轴伞轴套	Bearing support	1	
38	29.05.102	油封	Oil seal	1	
39	29.07.020	挡圈	Thrust collar	1	
40	01.10.039	螺钉	Screw	2	
41	29.01.034	变速箱下轴套	Bearing support	1	
42	29.01.070	7.94BTR旋梭	Hook 7.94BTR	1	
43	29.01.101	7.94ATR旋梭	Hook 7.94ATR	1	H
44	01.07.003	梭芯	Bobbin	1	
45	29.01.002	梭壳	Bobbin case	1	
46	29.01.138	旋梭定位销	Positioning finger	1	
47	01.10.010	螺钉	Screw	1	
48	02.09.021	下轴脚踏油窗	Oil window	1	
49	29.01.085	下轴	Hook driving shaft	1	
50	29.01.033	下轴中套	Bearing support	1	

4. 压脚分组件/Hang Lifter Components

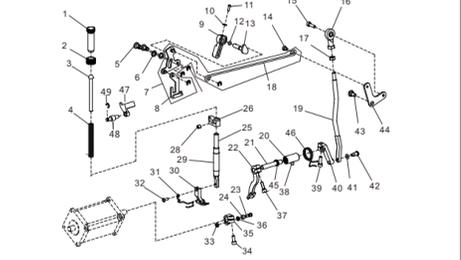

序号 Ref.No.	物料号 Part.No.	名称	Description	数量 Qty	备注 Remark
1	29.01.021	调压螺钉	Screw	1	
2	29.01.021A	调压螺母	Nut	1	
3	02.04.003	调压导杆	Presser guide bar	1	
4	29.01.078	调压簧	Spring	1	
5	02.09.014	螺紋套	Holder	2	
6	29.01.117	密封垫圈	Washer	2	
7	29.07.072	抬压脚踏杆部件	Lifting lever link	1	
8	XXXXX	压脚升降板	Plate	1	
9	02.02.010BZ	压脚扳手	Hand lifter	1	
10	02.02.003	垫圈	Washer	1	
11	02.09.012	螺钉	Screw	1	
12	02.02.018	O形圈	O-ring	1	
13	29.01.177	压脚扳手凸轮部件	Hand lifter CAM ASM.	1	
14	02.09.013	螺钉	Screw	1	
15	27.08.012	螺钉	Screw	1	
16	29.07.045	鱼眼接头	Fish eye joint	1	
17	29.07.091	六角螺母	Nut	1	
18	29.07.072-2	抬压脚踏杆	Lifting lever connecting rod	1	
19	29.07.072	抬压脚踏杆	Lifting lever connecting rod	1	
20	29.07.021	抬压脚踏套	Bearing support	1	
21	29.07.060	抬压脚踏	Shaft	1	
22	29.07.028	抬压脚踏曲柄	Crank	1	
23	29.07.049-2	螺钉	Screw	1	
24	29.07.049-3	滚珠	Screw	1	
25	29.01.112	压杆	Screw	1	
26	02.09.013	压杆导架	Presser guide bar bracket	1	
27	23.311	开口挡圈	Snap ring	1	
28	02.07.018	螺钉	Screw	1	
29	29.07.079	压杆轴套	Bearing support	1	
30	01.04.015	抬压脚踏部件	Presser foot ASM.	1	
31	01.04.015H	抬压脚踏部件	Presser foot ASM.	1	H
32	02.05.022	护脚架	Protect shell	1	
33	01.10.033	螺钉	Screw	1	
34	29.07.049-4	六角螺母	Nut	1	
35	29.02.134	螺钉	Screw	1	
36	29.07.049-5	垫圈	Washer	1	
37	29.02.134	螺钉	Screw	1	
38	02.09.008	螺钉	Screw	1	
39	29.02.134	螺钉	Screw	1	
40	29.07.031	抬压脚踏后曲柄	Crank	1	
41	01.03.012	O形圈	O-ring	1	
42	29.07.046	螺钉	Screw	1	
43	29.07.066	螺钉	Screw	1	
44	29.07.013	抬压脚踏后杆	Lifting lever link	1	
45	29.07.008	油封	Oil seal	1	
46	0000	弹簧	Spring	1	
47	XXXX	电磁铁抬压曲柄	Crank	1	
48	XXXX	铜子	Dowel	1	
49	XXXX	开口挡圈	Snap ring	1	

5. 剪 分组件/Thread Trimmer Components

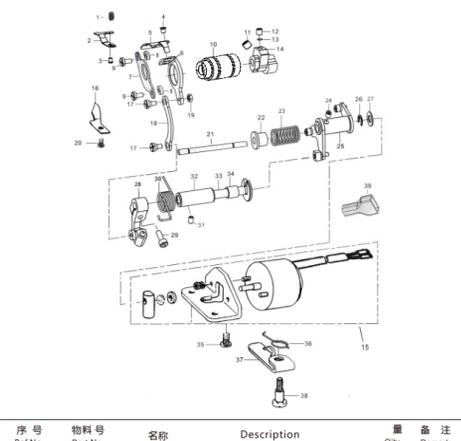

序号 Ref.No.	物料号 Part.No.	名称	Description	数量 Qty	备注 Remark
1	XXXX	固定刀	Fixed knife	1	
2	XXXX	固定刀螺钉	Screw SM9/64*40 L=9	1	
3	XXXX	固定刀螺钉	Screw SM9/64*40 L=4	1	
4	XXXX	固定刀螺钉	Screw SM11/64*40 L=4	2	
5	29.01.017	剪刀	Moterial knife	1	
6	29.01.044	刀架	Knife bracket	1	
7	29.01.042	刀架压板	Knife bracket presser	1	
8	XXXX	刀架压板垫圈	Washer	1	
9	29.01.007	压板紧固螺钉	Screw SM11/64*40 L=8	2	
10	29.01.211	下轴前轴套	Bearing support	1	
11	XXXX	剪线凸轮固定螺钉	Screw 1/4*40 L=10	1	
12	XXXX	剪线凸轮固定螺钉	Screw 1/4*40 L=6	1	
13	XXXX	剪线凸轮垫片	Washer	1	
14	29.01.047	切线凸轮	Thread cutter cam	1	
15	XXXX	剪线电磁铁组件	Mthread trimmer solenoid asm	1	
16	29.06.017	分线器	Hneedle guard patch	2	H
17	XXXX	刀轴连杆螺钉	Screw SM11/64*40	2	
18	29.01.029	刀轴连杆	Connecting rod	1	
19	XXXX	刀轴连杆螺母	Nut SM11/64*40	1	
20	02.09.034	分线器固定螺钉	Screw SM9/64*40 L=6	1	
21	29.01.048	刀轴驱动轴	Thread cutter driving shaft	1	
22	XXXX	扭簧盖	Spring cover	1	
23	XXXX	切线凸轮复位簧	Spring	1	
24	XXXX	剪线凸轮固定螺钉	Screw SM1/4*40 L=6	1	
25	29.01.046	剪线凸轮凸轮大组件	Thread trimmer cam crank asm	1	</