

PF-HB / PF-RB 組合圖 THE COMBINATION OF PF-HB / PF-RB

請依編號順序組合
Please assemble the device according to the indicated numbers.

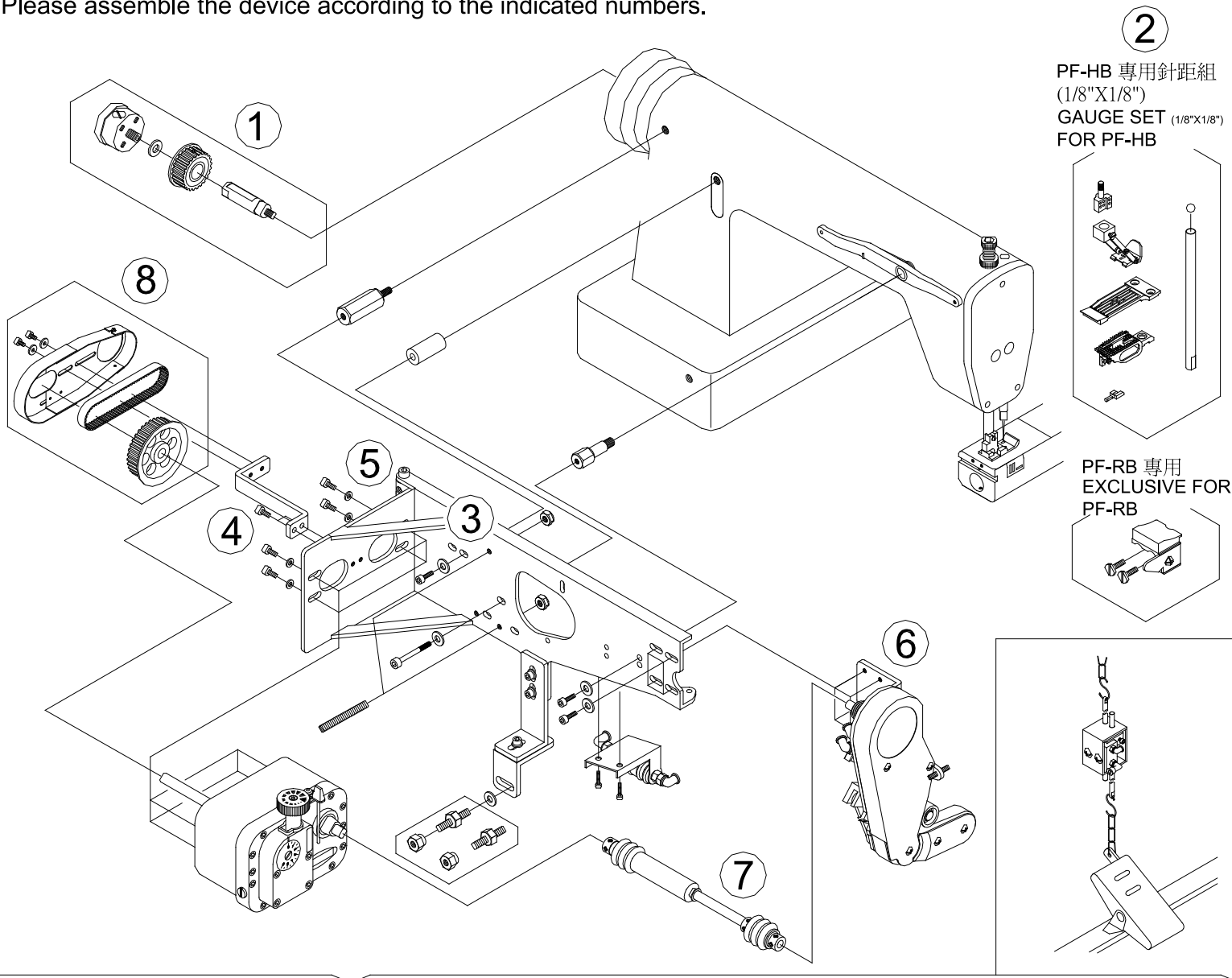

1 皮帶輪螺柱
STUDS FOR PULLEYS

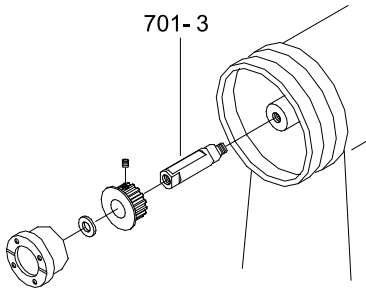

PF-HB 專用 EXCLUSIVE FOR PF-HB

2 更換PF-HB專用針距組 (1/8"x1/8")
CHANGE TO GAUGE SET (1/8"x1/8") FOR PF-HB

1.準備工作
FORE-WORK

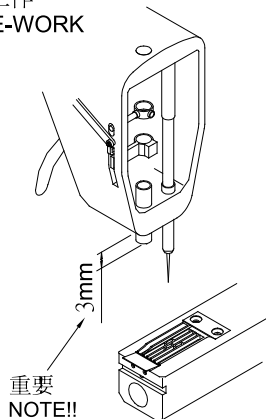

2.完成圖
INSTALLATION COMPLETED

PF-HB 專用針距組
(1/8"X1/8")
GAUGE SET (1/8"X1/8")
FOR PF-HB

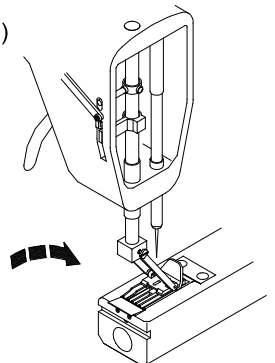
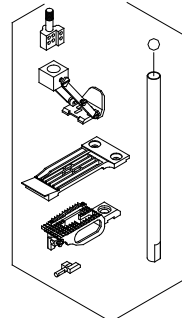

3 固定變速機架 FIXING TRANSMISSION BRACKET

請優先安裝 (A) 螺絲後,再依下列機型編號固定其他螺絲
Please install the screw (A) at first, then fix other screws according the below model numbers.

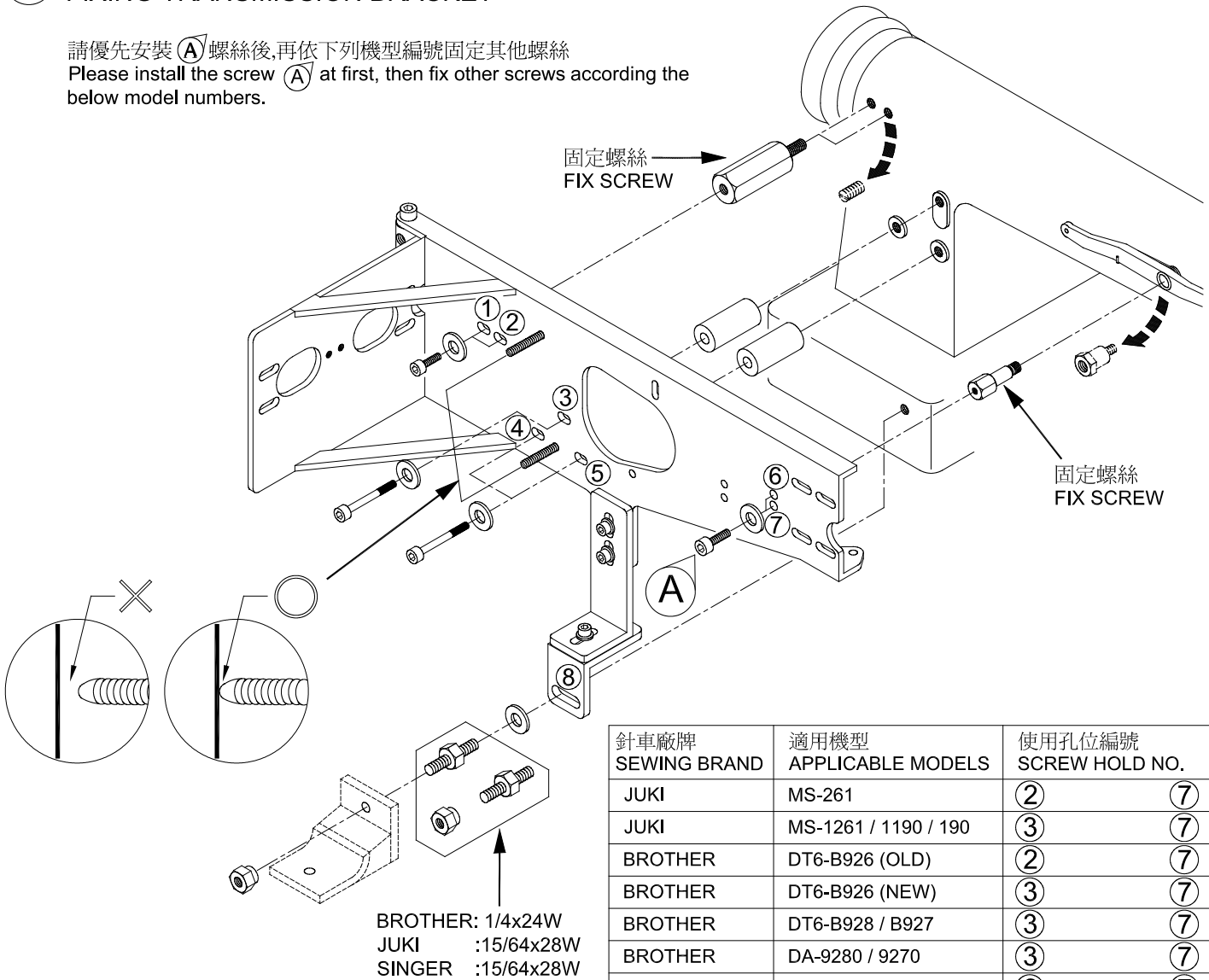

BROTHER: 1/4x24W
JUKI :15/64x28W
SINGER :15/64x28W

針車廠牌 SEWING BRAND	適用機型 APPLICABLE MODELS	使用孔位編號 SCREW HOLD NO.				
JUKI	MS-261	②	⑦	⑧		
JUKI	MS-1261 / 1190 / 190	③	⑦	⑧		
BROTHER	DT6-B926 (OLD)	②	⑦	⑧		
BROTHER	DT6-B926 (NEW)	③	⑦	⑧		
BROTHER	DT6-B928 / B927	③	⑦	⑧		
BROTHER	DA-9280 / 9270	③	⑦	⑧		
JEAN LIAN	926	②	⑦	⑧		
TONY	928	③	⑦	⑧		
SEIKO	LDA-T26-1	①	④	⑤	⑥	⑧
SINGER	261U	①	④	⑤	⑥	⑧

4 安裝變速機 INSTALLING TRANSMISSION

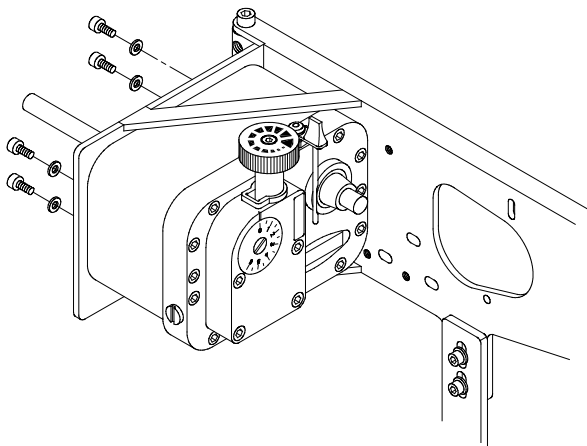

5 基座固定 FIXING BRACKET

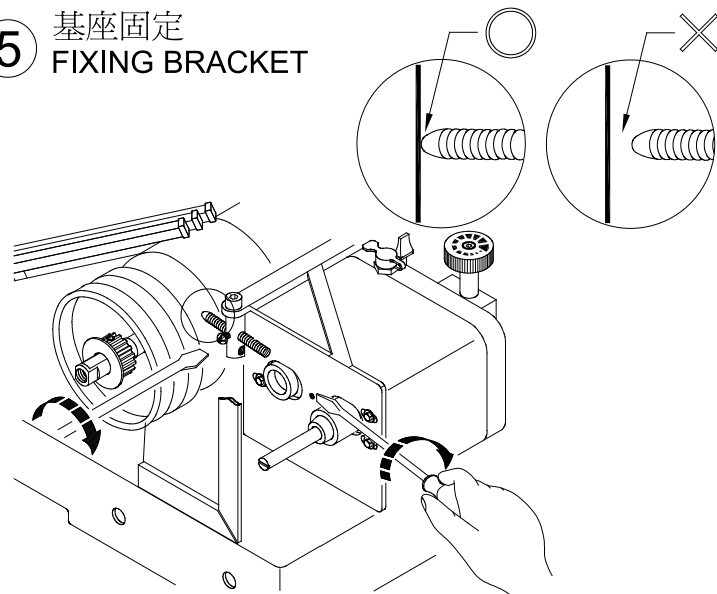

6 拉布皮帶各方向位置調整
PULLING BELT IS ADJUSTABLE FOR EVERY DIRECTION

左右與水平調整螺
SCREW FOR ADJUSTING
RIGHT AND LEFT SIDES
AND HORIZONTAL

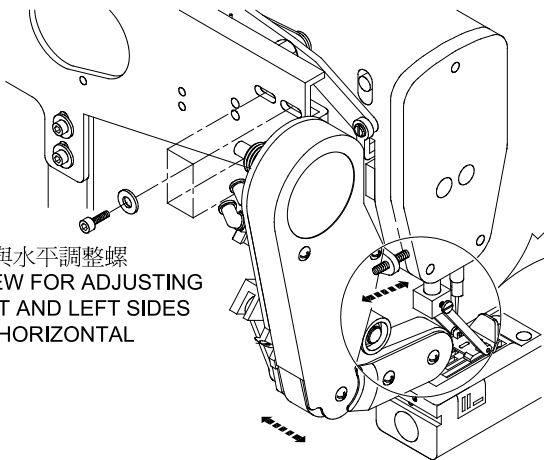

針下時,皮帶要與針板面吻合,否則空環出線困難
When needle down, belt must touch the needle plate properly,
otherwise the non-sewn chain stitches will come out difficulty.

前後調整螺
SCREW FOR ADJUSTING
FORWARD AND BACKWARD

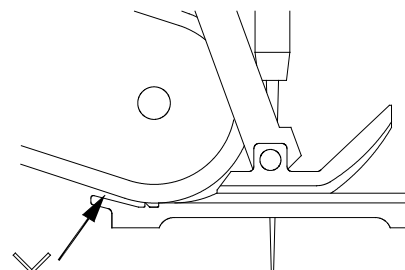
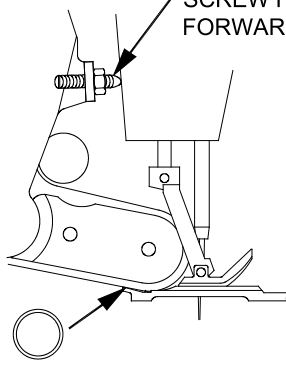

重 要:皮帶與針板間不能有間隙
NOTE:No space between belt
and needle plate

7 安裝萬向接頭
FIXING UNIVERSAL JOINT

重要!
按裝萬向接頭時兩頭螺絲須成一條直
線否則快慢不均
NOTE ! Keep the screws of all
universal joints in perfect alignment to
eliminate uneven motion.

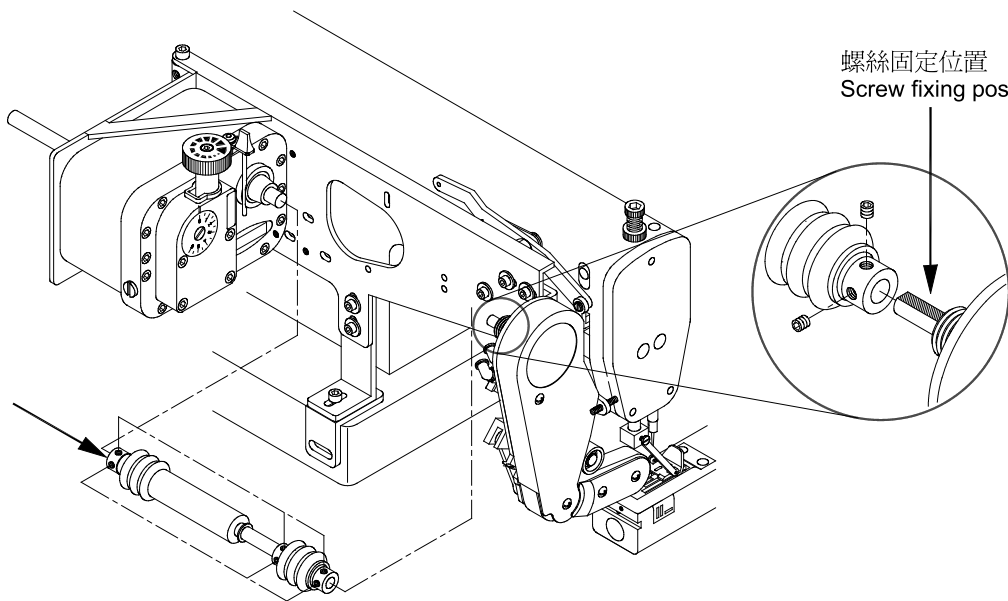

螺絲固定位置
Screw fixing position

8 -1 固定皮帶輪
FIXING CONNECTING STUD.

掛上皮帶
Put belt on

暫勿上緊螺絲直到第 8-3 步驟
Do not tighten the screw until NO. 8-3

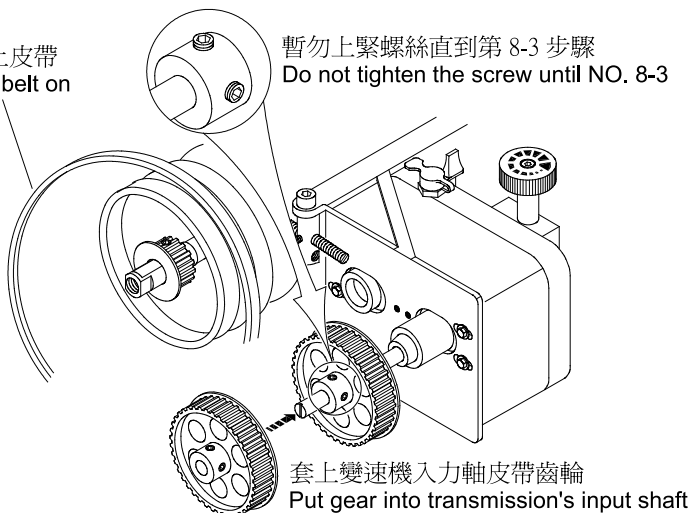

套上變速機入力軸皮帶齒輪
Put gear into transmission's input shaft

8 -2 安裝皮帶
INSTALLING TIMING BELT

時規齒輪要成平行
Timing gears must be
parallel

調整時規皮帶鬆緊度
Adjust tension of timing belt

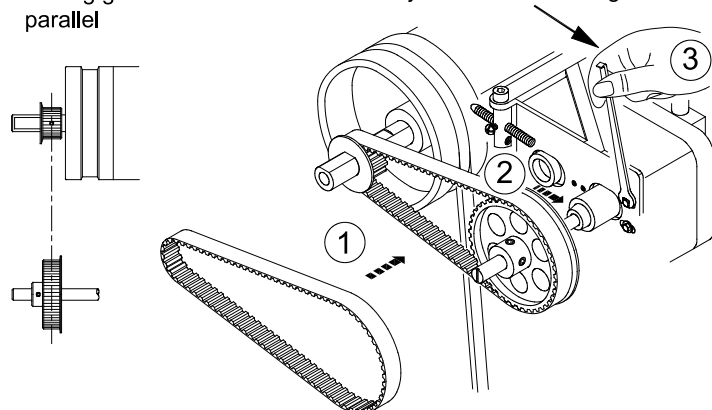

8 -3 變速機入力軸定位
ADJUST TRANSMISSION'S INPUT SHAFT POSITION

變速機的紅線對齊入力軸紅線後,上緊時規齒輪螺絲
 Meet the both red line on transmission input shaft, tighten the timing gear screw.

車針提升至最高點
 Needle to the toppest position

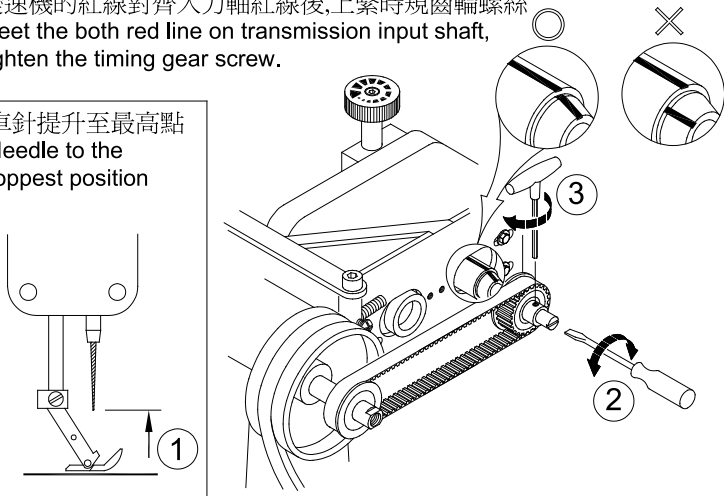

8 -4 安裝皮帶護蓋
INSTALLING BELT COVER

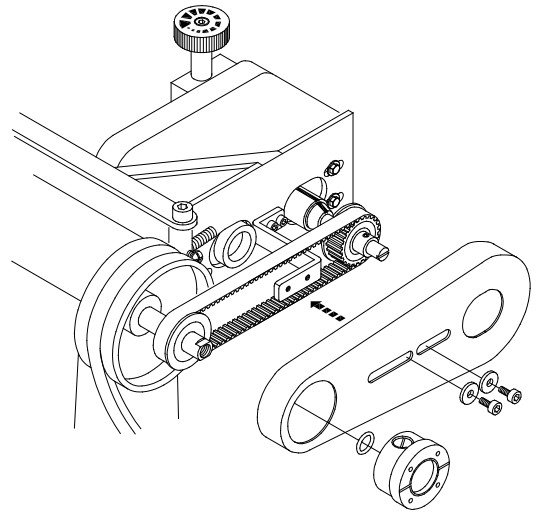

調整 ADJUSTMENT

拉布皮帶的動作量應比送齒稍大,但差率太多時拉布皮帶則易磨損

The pulling belt's feeding amount should be properly larger than feed dog's to procure even effect on sewn material. But if it is overmuch, pulling belt will be torn easily.

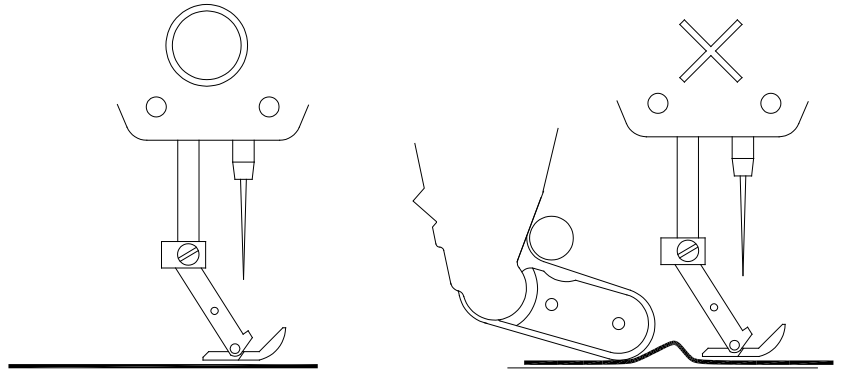
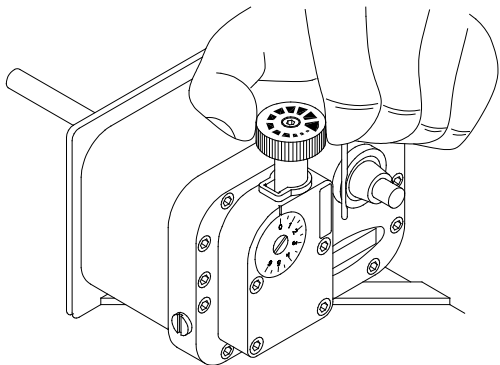

厚薄布料調整 (PF-RB專用)
ADJUSTMENT FOR THICK AND THIN MATERIAL (EXCLUSIVE FOR PF-RB)

薄物
 Thin material

厚物
 Thick material

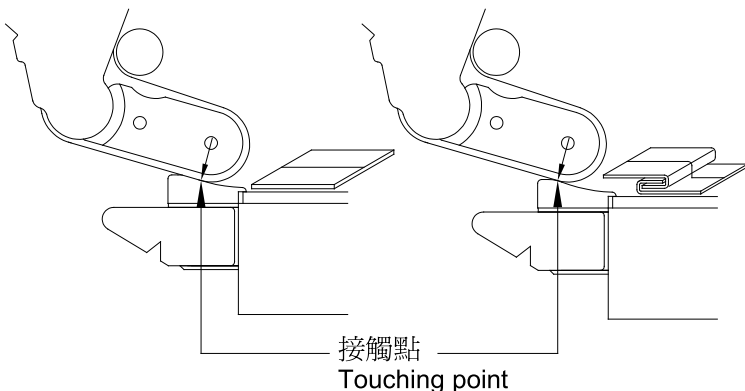

拉布皮帶角速度圖
PULLING BELT SPEED

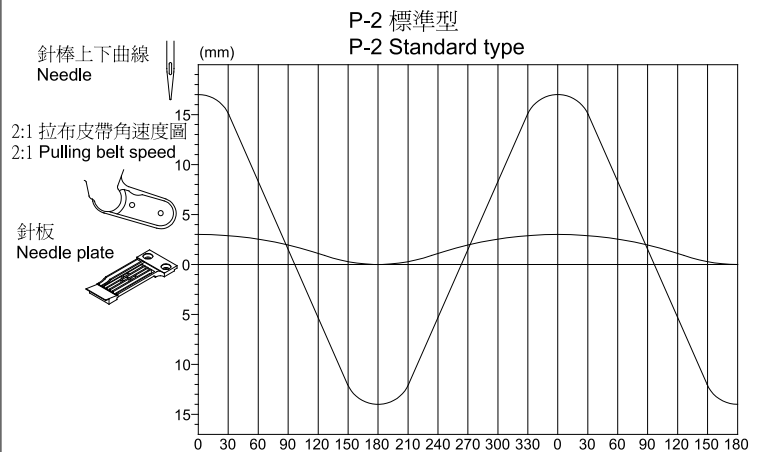

PF-HB / PF-RB 管路圖

AIR HOUSE PLUG DIAGRAM FOR PF-HB / PF-RB

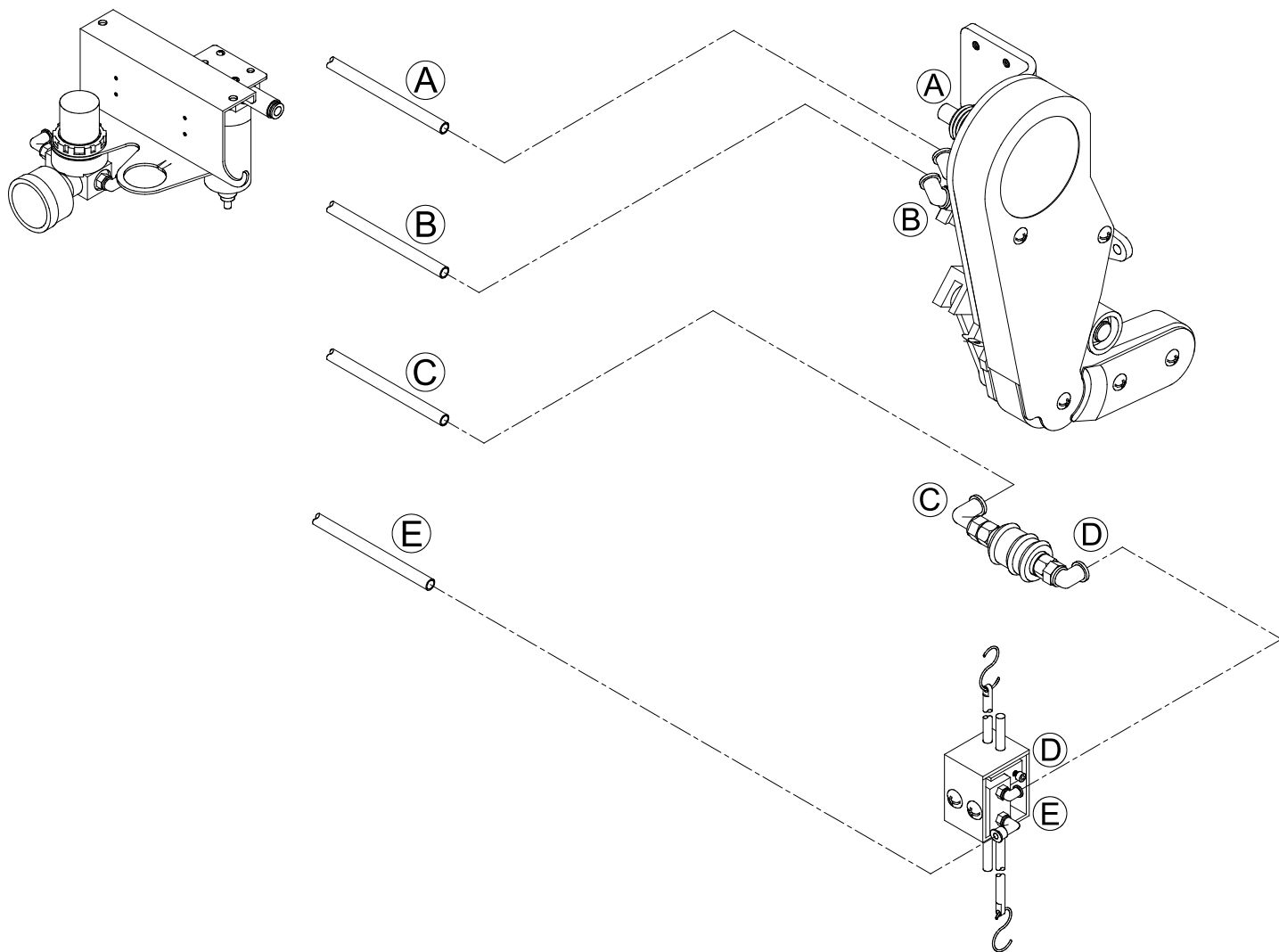

PF-HB / PF-RB 零件圖

PARTS LIST FOR PF-HB / PF-RB

記號說明

Mark description

- ? 選擇性配件,請告知針車廠牌機型
- Please indicate sewing machine model No. for optional parts.

選擇性配件

Optional parts

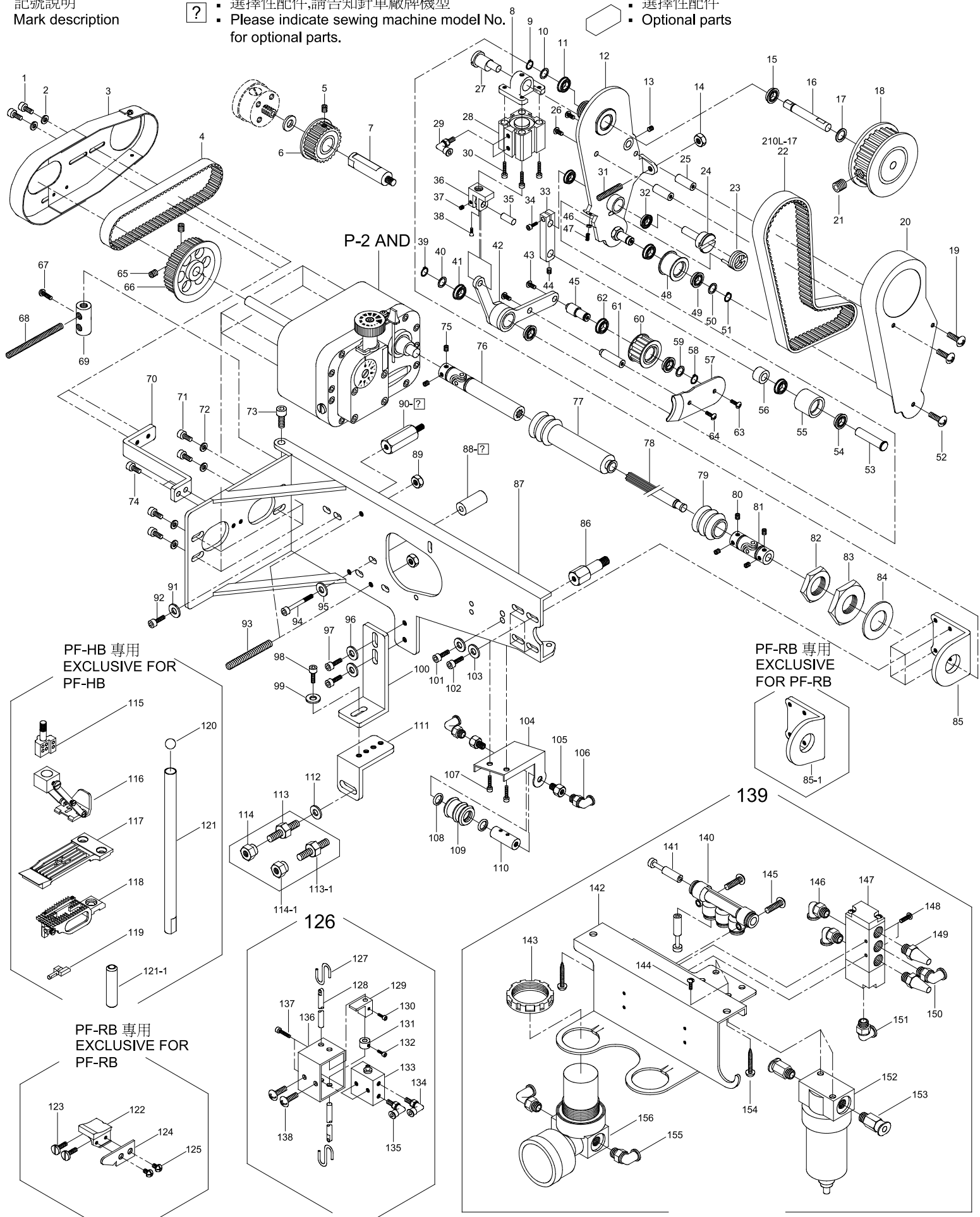

ECV 自動切線 組合圖 (選擇性配件)

THE COMBINATION OF ECV CHAIN CUTTER (OPTIONAL PARTS)

安裝固定片
INSTALL FIXER

PF-HB

例一
EXAMPLE 1

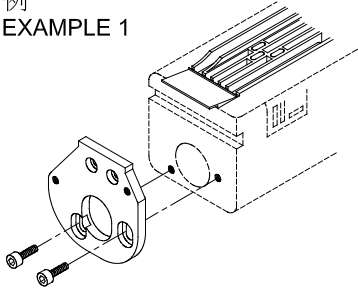

例二
EXAMPLE 2

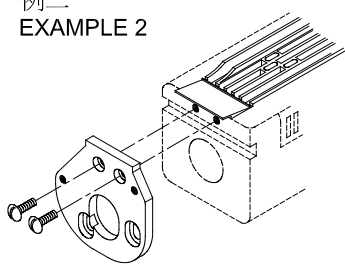

PF-RB

例一
EXAMPLE 1

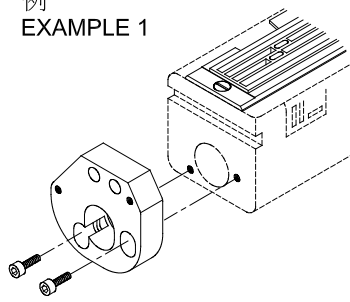

例二
EXAMPLE 2

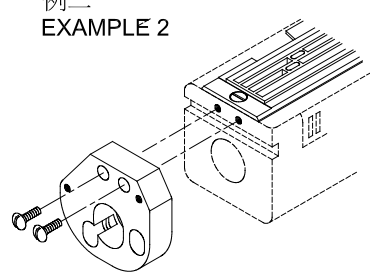

固定切刀
FIX CHAIN CUTTER

PF-HB

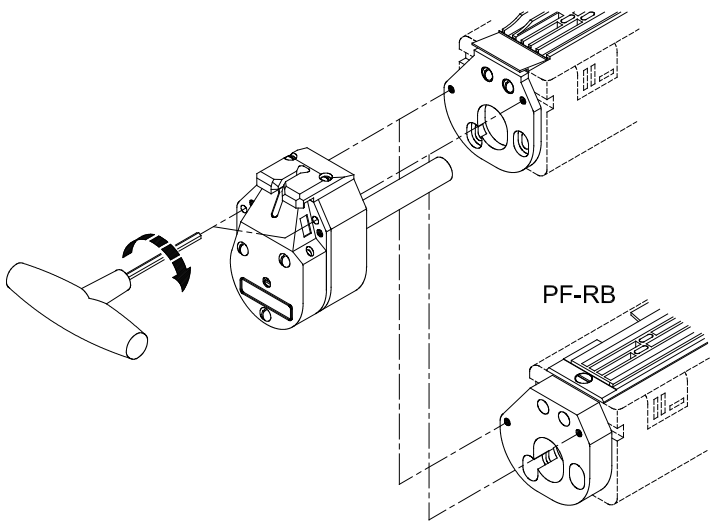

PF-RB

腳踏開關
PEDAL SWITCH

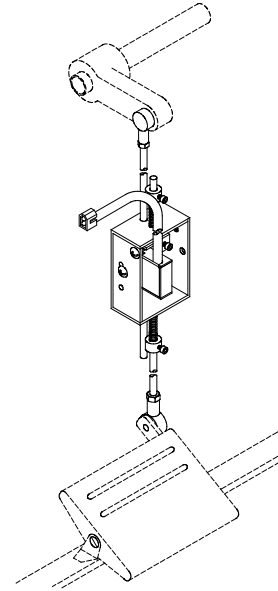

集屑袋
CHAN & WASTE COLLECTION BAG

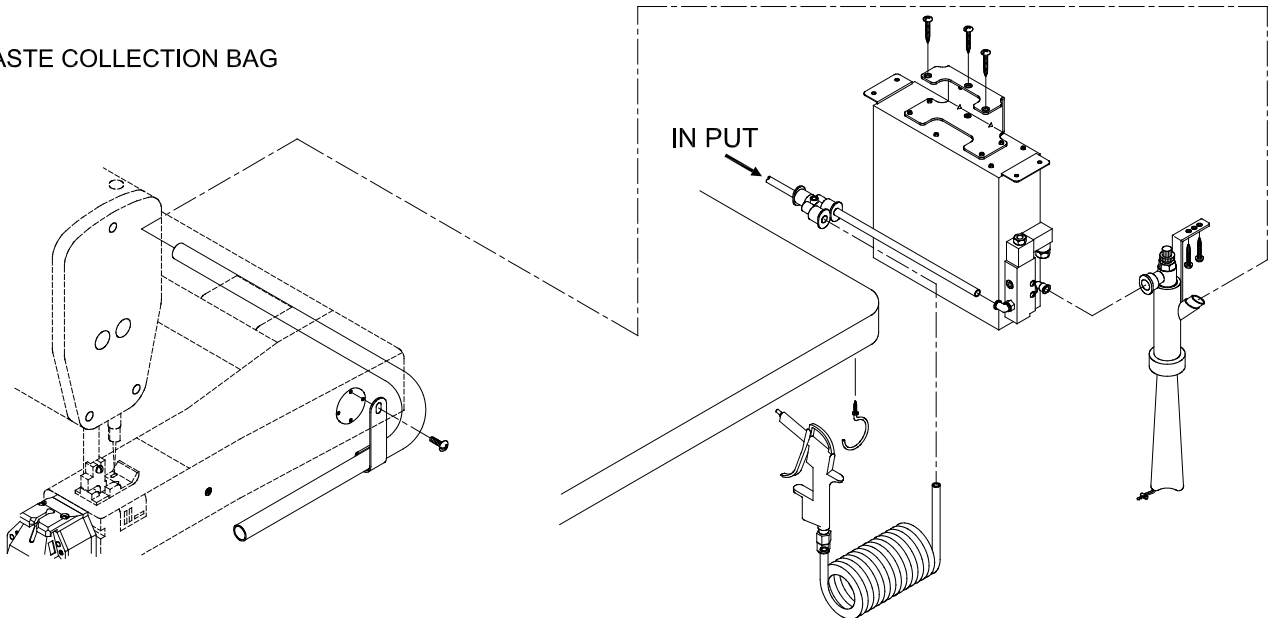

PF-HB / ECV 管路圖 (選擇性配件)

AIR HOUSE PLUG DIAGRAM FOR PF-HB / ECV (OPTIONAL PARTS)

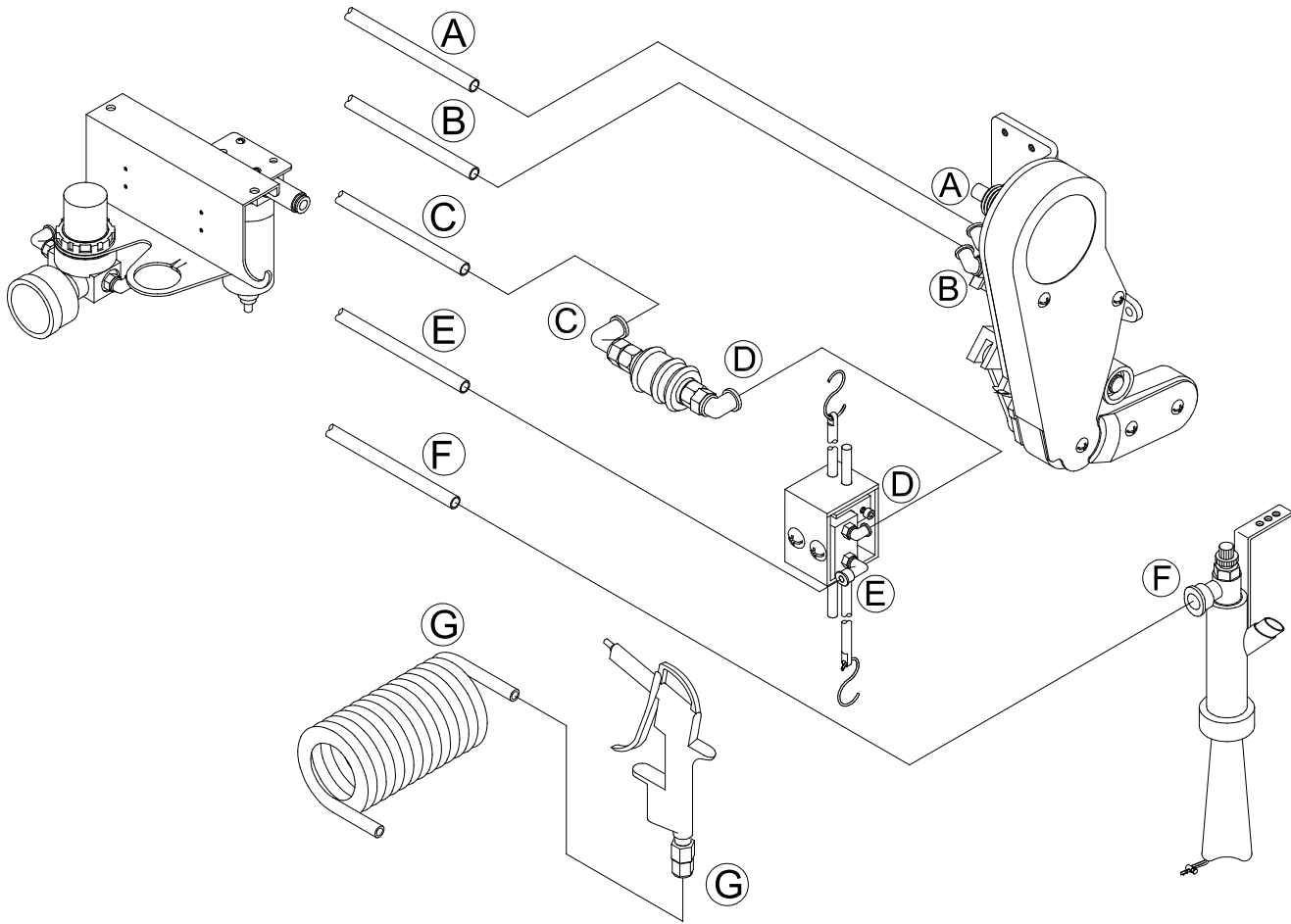

ECV 自動切線 接線圖 (選擇性配件)

WIRING DIAGRAM FOR ECV CHAIN CUTTER (OPTIONAL PARTS)

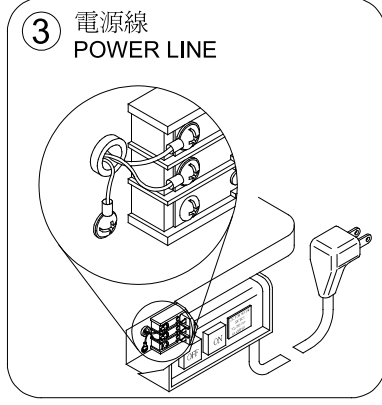
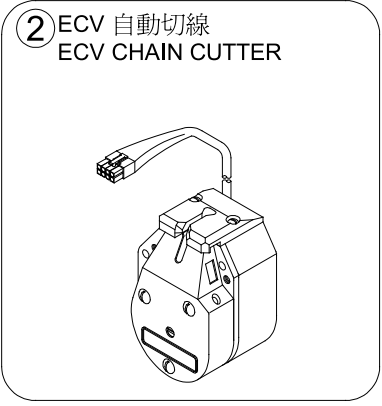
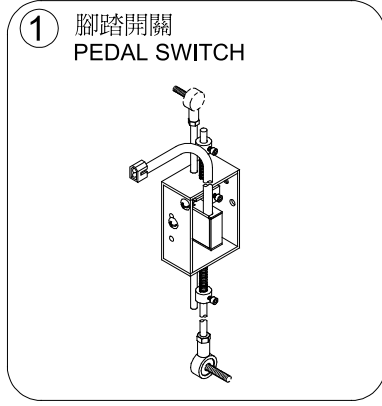
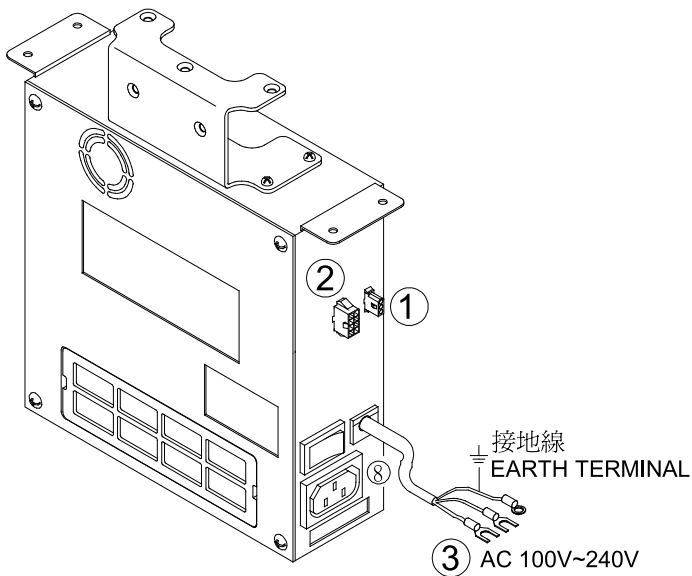

ECV自動切線 零件圖 (選擇性配件)

PARTS LIST FOR ECV CHAIN CUTTER (OPTIONAL PARTS)

記號說明
Mark description

? 選擇性配件,請告知針車廠牌機型
Please indicate sewing machine model No. for optional parts.

選擇性配件
Optional parts

157

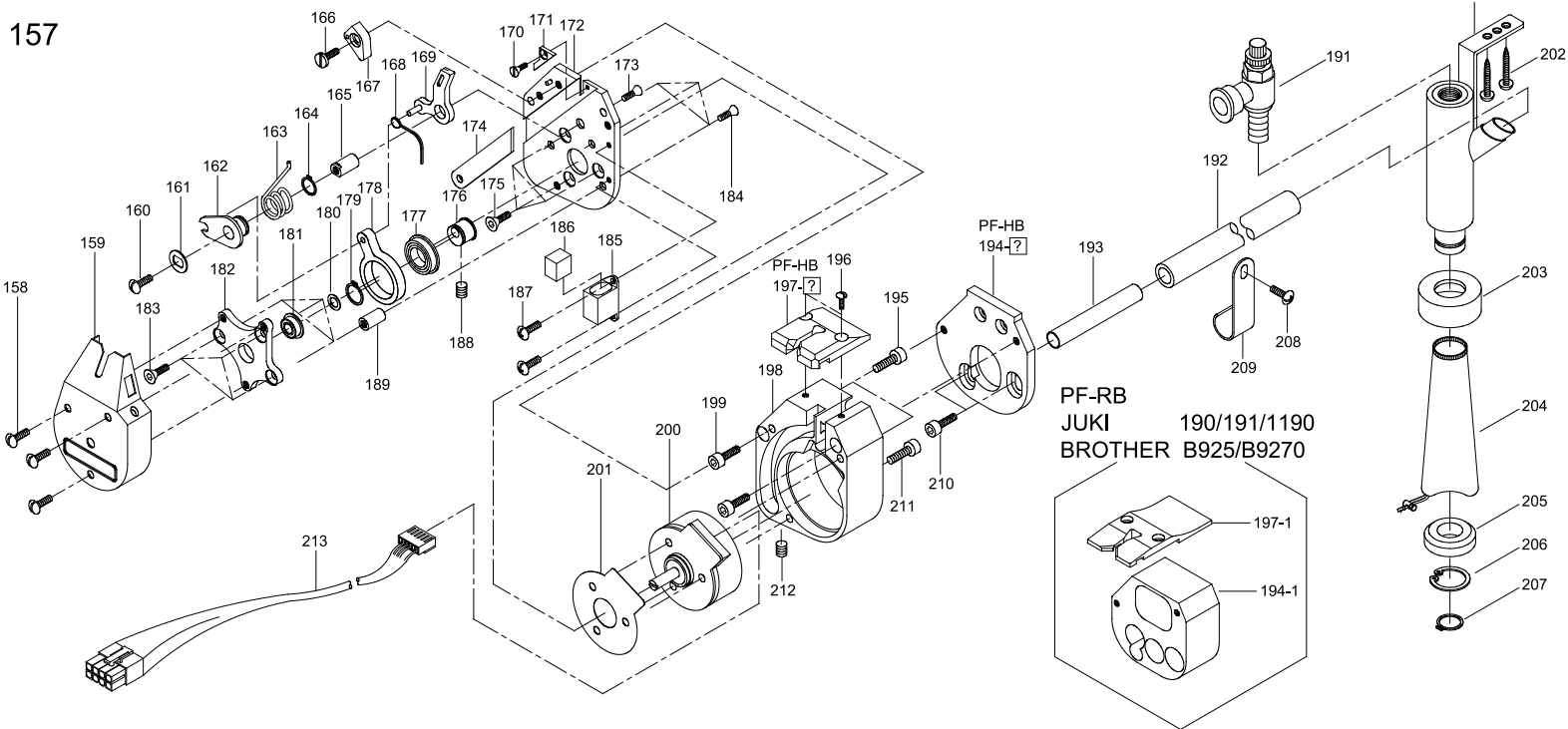

214

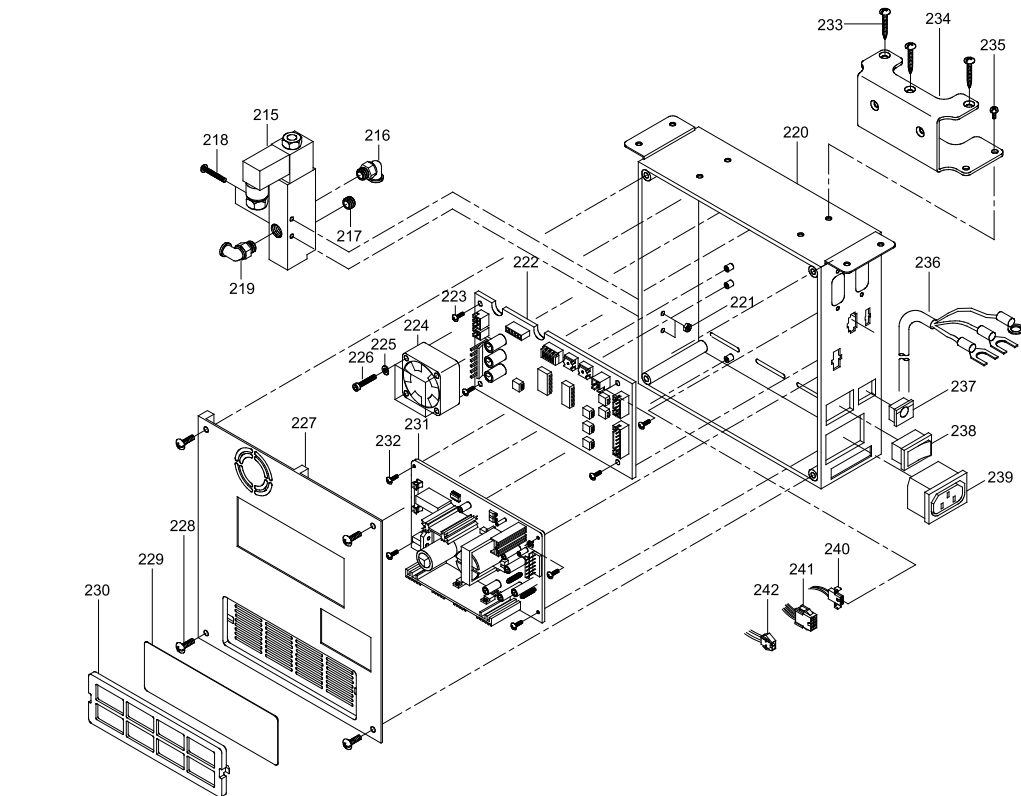

243

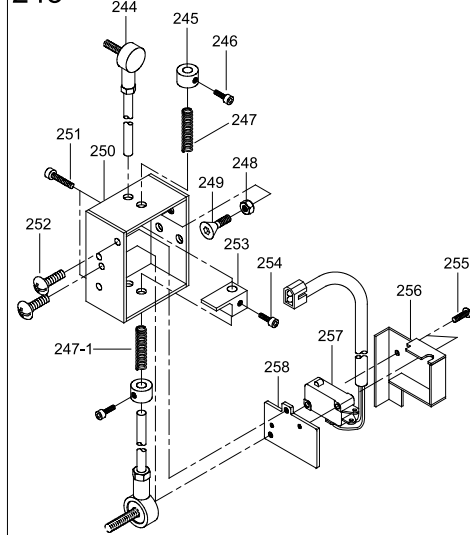

259

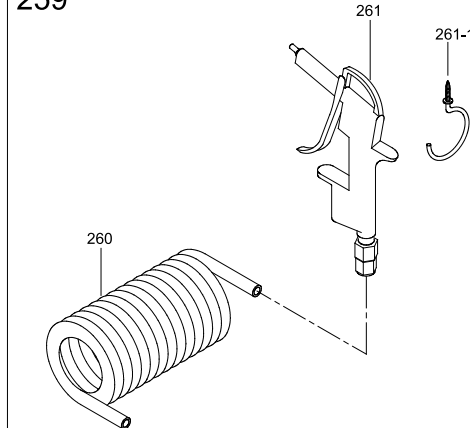

AF 壓腳提升組合圖 (選擇性配件)

THE COMBINATION OF AIRCONTROL FOOT (OPTIONAL PARTS)

準備工作
FORE-WORK

① 拆下壓腳棒與上套筒
Take off presser foot bar and upper bush

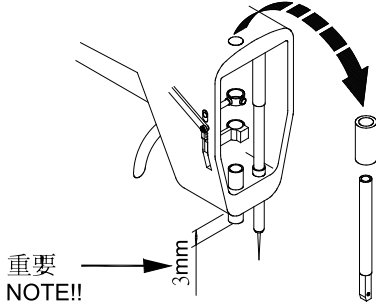

② 安裝壓腳桿限位座
Install stopper for presser foot link

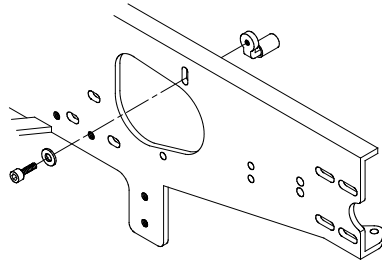

③ 更換壓腳提升板
Change presser foot lifting plate

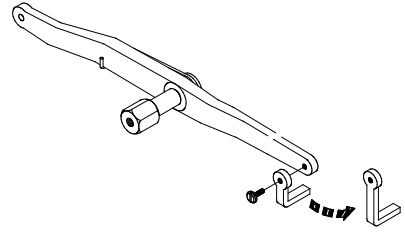

請依編號順序組合
Please assemble the device according to the indicated numbers.

完成圖
INSTALLATION COMPLETED

腳踏開關
PEDAL SWITCH

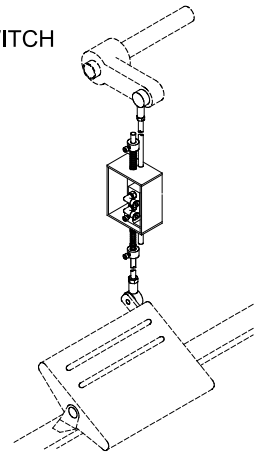
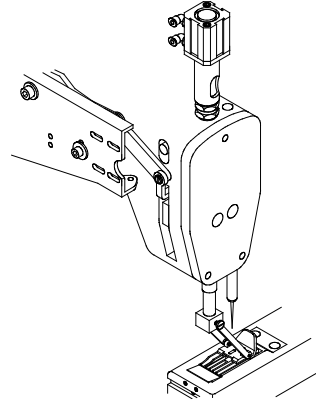
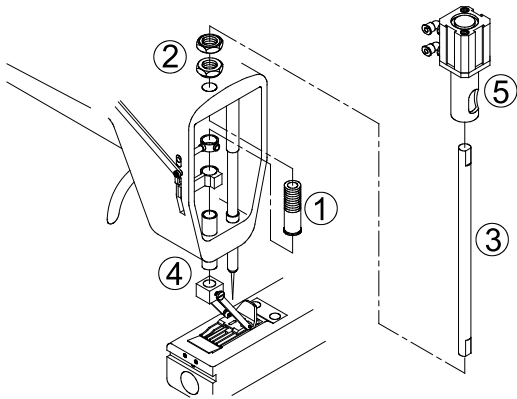

PF-HB / AF 管路圖

AIR HOUSE PLUG DIAGRAM FOR PF-HB / AF

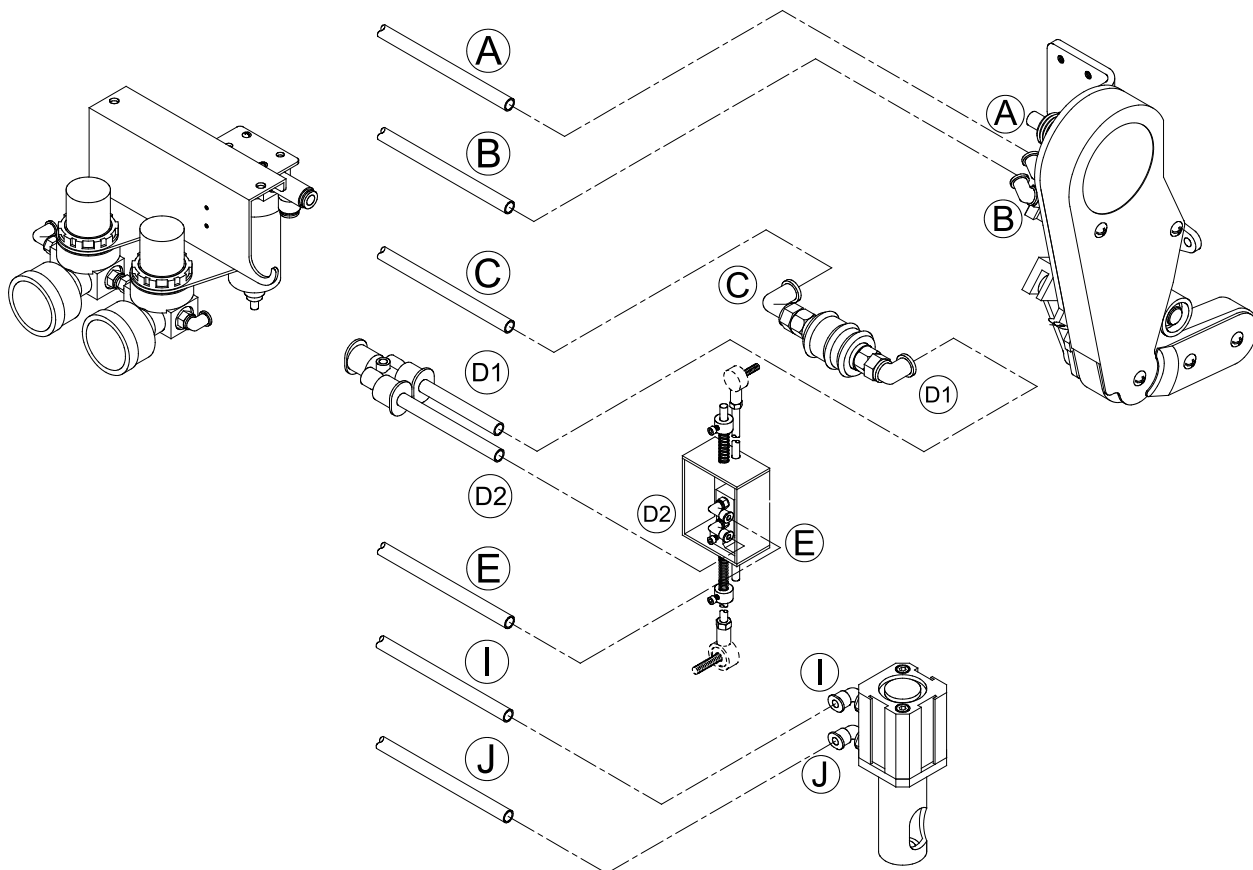

AF壓腳提升 零件圖 (選擇性配件)

PARTS LIST FOR AIRCONTROL FOOT (OPTIONAL PARTS)

記號說明
Mark description

 選擇性配件,請告知針車廠牌機型
Optional parts, Please indicate sewing machine model No. for optional parts.

 選擇性配件
Optional parts

262

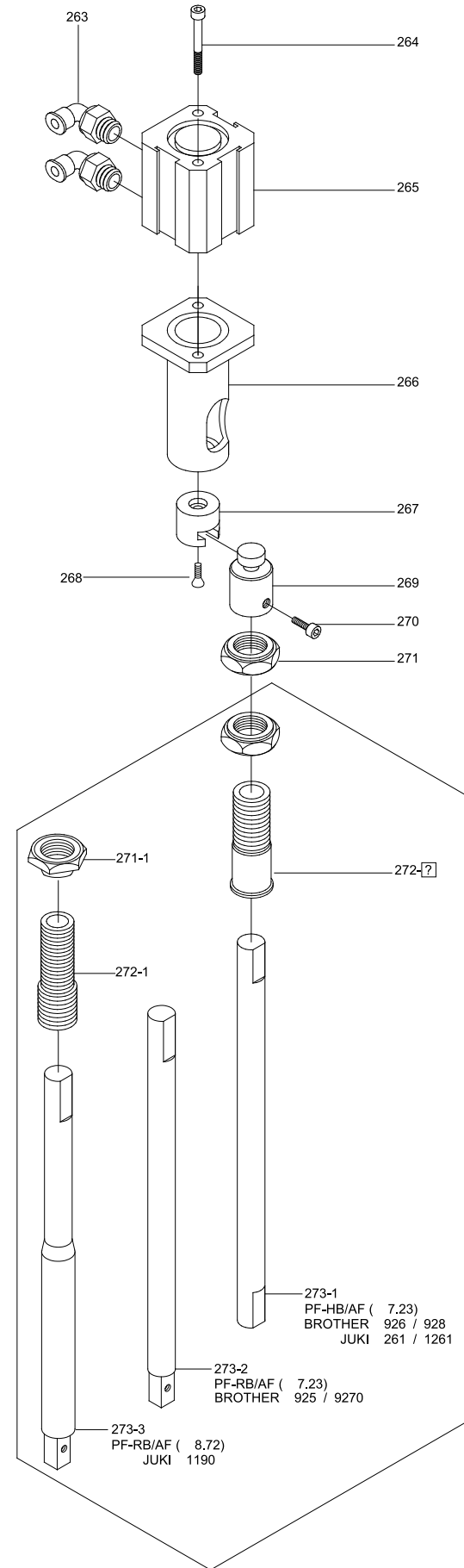

274

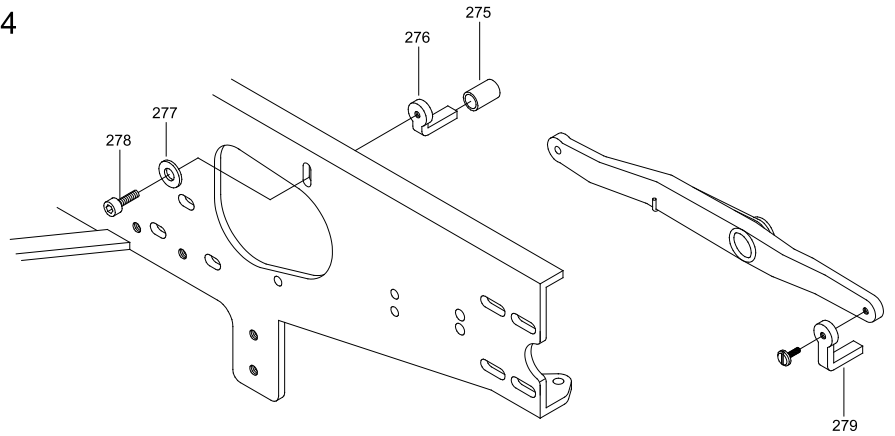

280

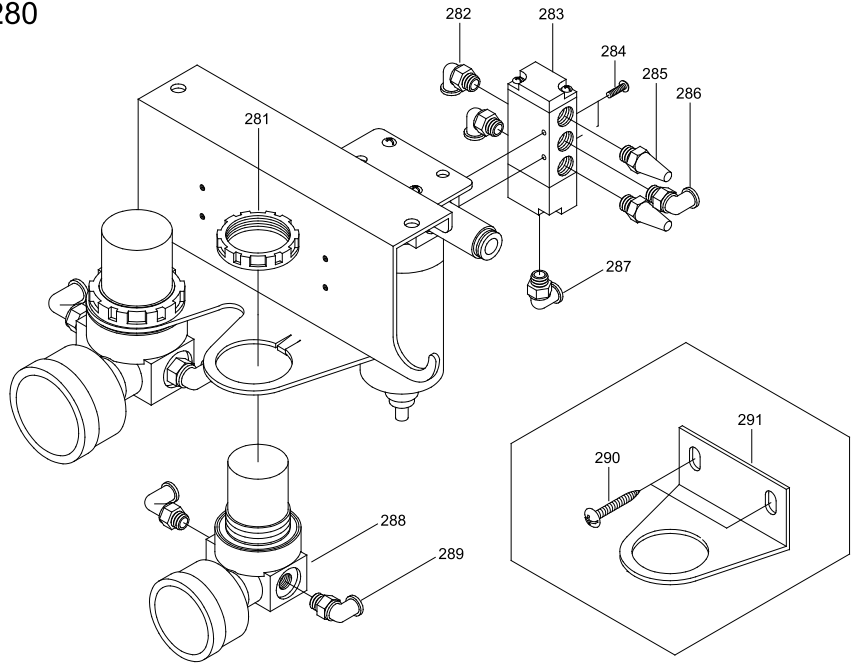

292

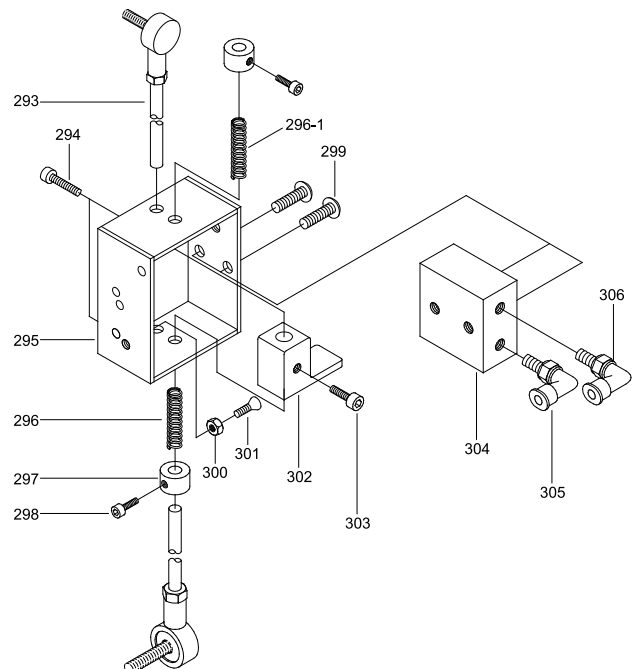

PF-HB / ECV / AF 管路圖

AIR HOUSE PLUG DIAGRAM FOR PF-HB / ECV / AF

