

# 目錄

## CONTENTS

	頁數 Page
PF-UB 組合圖 ----- THE COMBINATION OF PF-UB	2
安裝步驟 ----- INSTALLATION GUIDE	3-4
PF-UB 調整 / 管路圖 / PF-UB / EFV / AF 管路圖 ----- SETTING / AIR HOSE PLUG DIAGRAM FOR PF-UB / AIR HOSE PLUG DIAGRAM FOR PF-UB / EFV / AF	5
AF 氣動壓腳提升裝置安裝說明、管路圖 (選擇性配件) ----- INSTALLATION GUIDE FOR AF (OPTIONAL PARTS) / AIR HOSE PLUG DIAGRAM (OPTIONAL PARTS)	6
EFV 組合圖 (選擇性配件) ----- THE COMBINATION OF EFV (OPTIONAL PARTS)	7
EFV 管路圖、自動切線 接線圖 (選擇性配件) / 保養 ----- AIR HOSE PLUG DIAGRAM FOR EFV (OPTIONAL PARTS) / WIRING DIAGRAM FOR EFV CHAIN CUTTER (OPTIONAL PARTS) / MAINTENANCE	8
PF-UB 零件圖 ----- PARTS LIST FOR PF-UB	9
EFV自動切線零件圖 (選擇性配件) ----- PARTS LIST FOR EFV CHAIN CUTTER (OPTIONAL PARTS)	10
AF壓腳提升零件圖 (選擇性配件) ----- PARTS LIST FOR PNEUMATIC PRESS FOOT LIFTER (OPTIONAL PARTS)	11
<p>保固期限：壹年，日期如無法查證時以出廠日期起18個月為準 (不含時規皮帶與其他消耗品)</p> <p>Warranty : One year or 18 months after manufactured data. ( Except the Timing and other consumables parts )</p>	

# PF-UB 組合圖 THE COMBINATION OF PF-UB

請依編號順序組合

Please assemble the device according to the indicated numbers.

 標準配件，選擇使用  
Standard parts, choose the suitable one

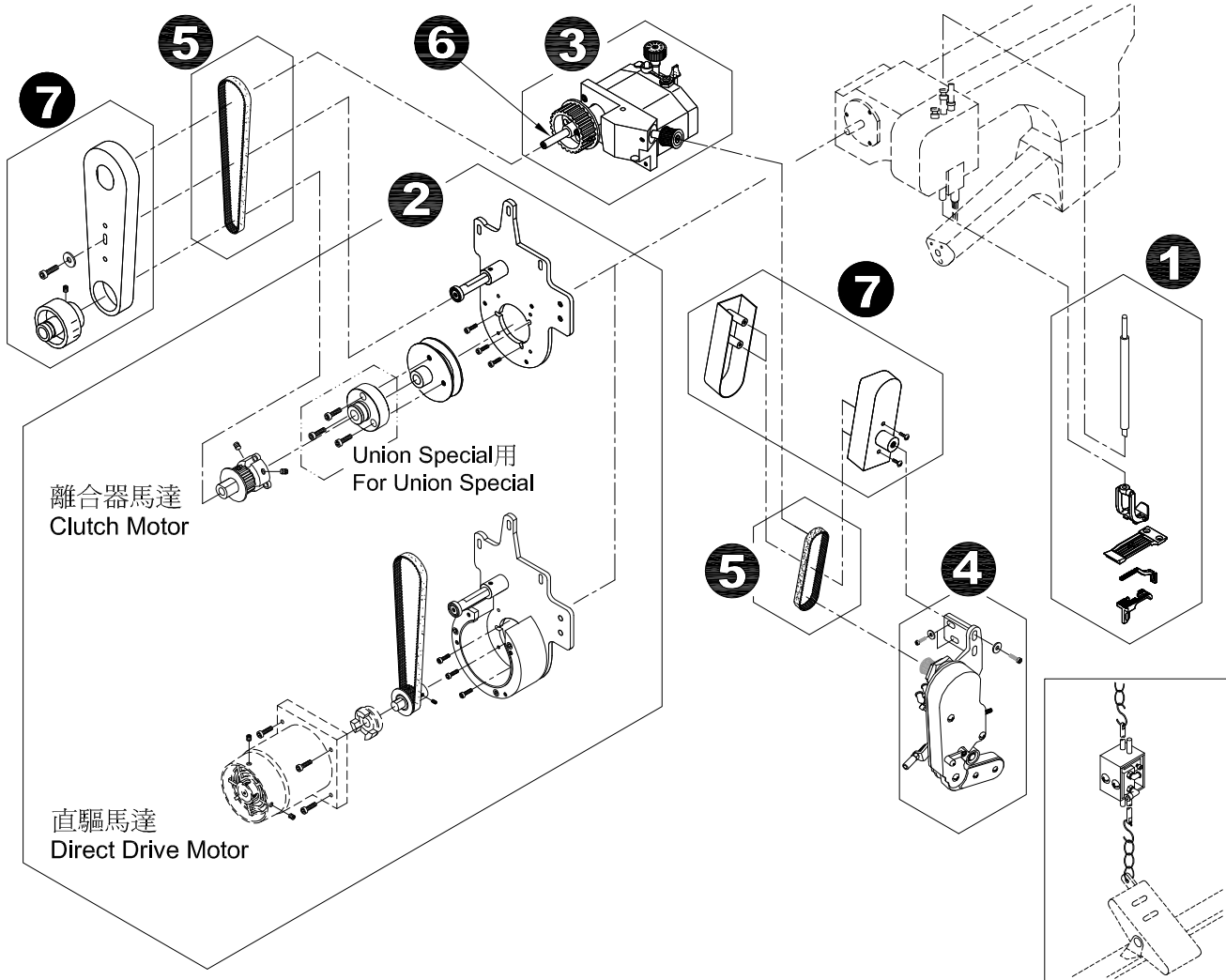

## 準備工作 ADVANCE WORK

拆下零件  
Dismantle parts

 記號為拆下待用品  
The parts in mark are dismantled for standby

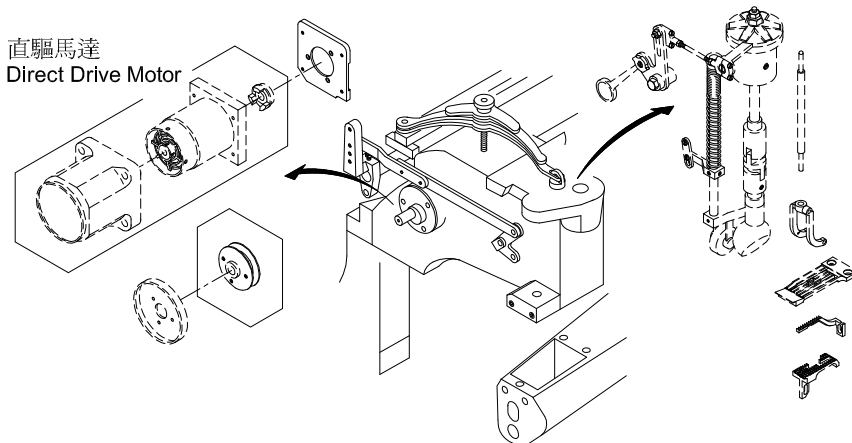

AF 壓腳提升 (選擇性配件)  
For Pneumatic presser foot lifter (optional parts)

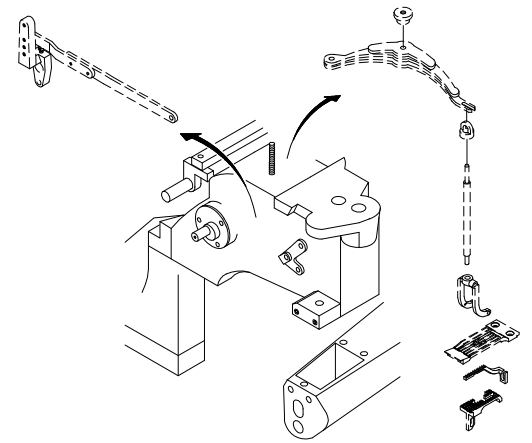

# 安裝步驟 INSTALLATION GUIDE

## 1 安裝壓腳.針距組 Install presser foot & gauge set

○ : 記號為拆下待用品  
The parts in mark are dismantled for standby

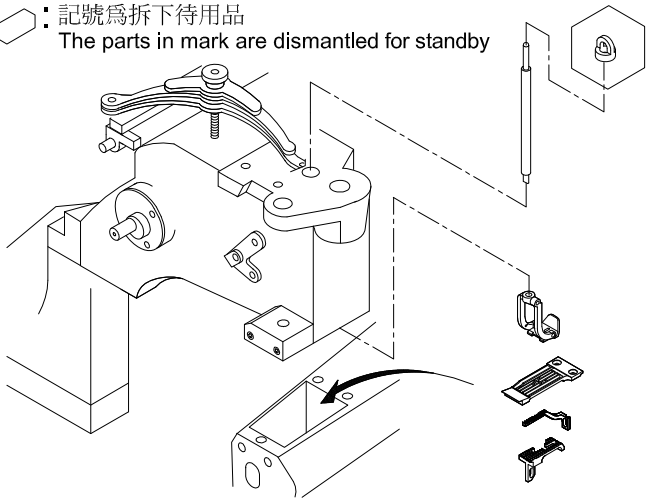

## AF 壓腳提升 (選擇性配件) Pneumatic presser foot lifter (optional parts)

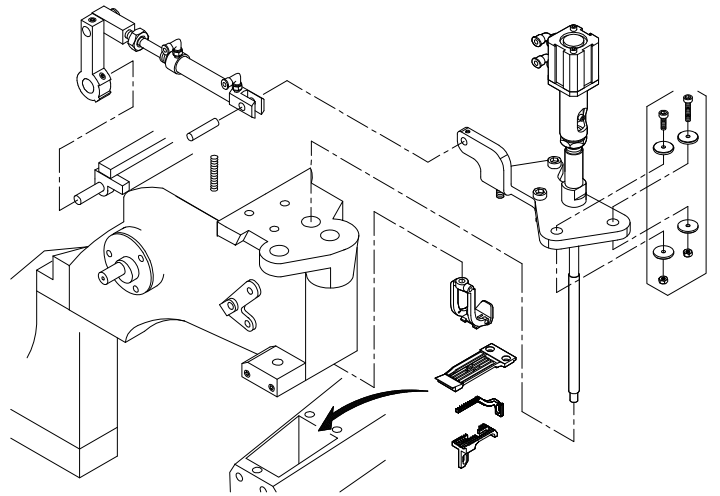

## 2 安裝變速機座 Install transmission bracket

離合器馬達  
Clutch Motor

Union Special 用  
For Union Special

直驅馬達  
Direct Drive Motor

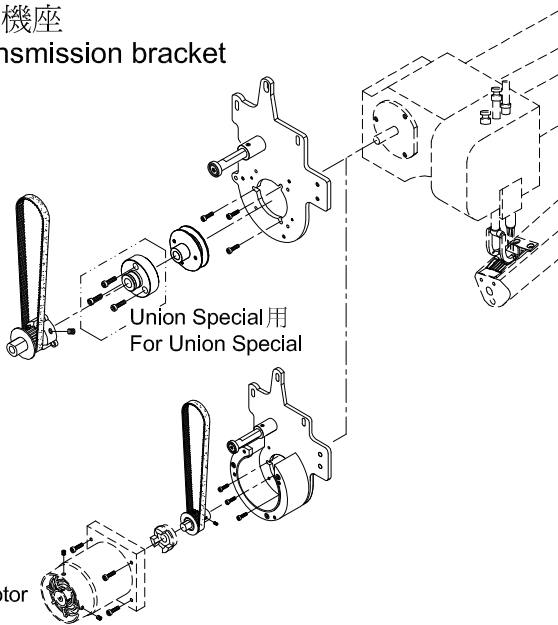

## 3 安裝變速機 Install Transmission

暫勿上緊螺絲直到第 5 - 3 步驟

Do not tighten the screw until step 5 - 3

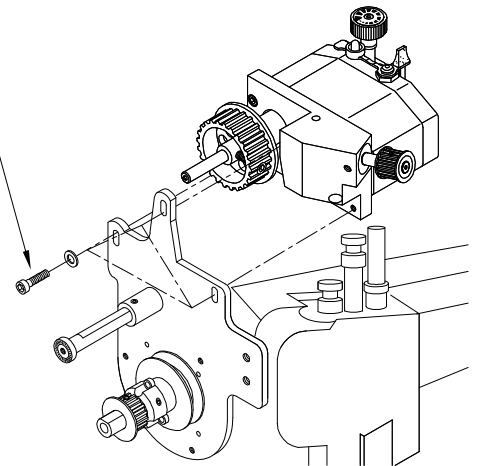

## 4 安裝皮帶拖輪組 Install belt puller

皮帶式拖輪與針孔成一直線  
Puller belt must be aligned to needle hole

3 固定  
Fixing

前後調整螺  
Screw for adjusting forward and backward

重要：皮帶與針板的接觸點是在針板的齒狀上  
Important: The touching position of belt should meet the teeth of needle plate

接觸點偏後  
Touching position is over backward

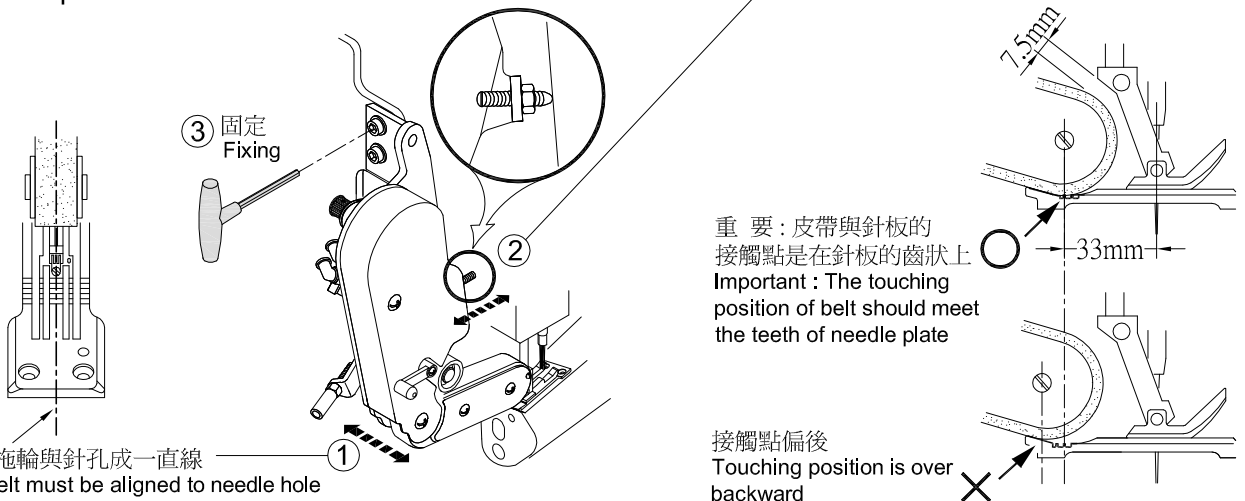

# 安裝步驟 INSTALLATION GUIDE

## 5 安裝皮帶 Install belt

① 安裝皮帶  
Install belt

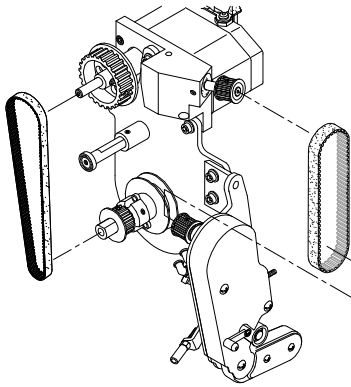

③ 上緊變速機架螺絲  
Tighten the screw of  
transmission bracket

② 調整時規皮帶鬆緊度  
Adjust tension of timing belt

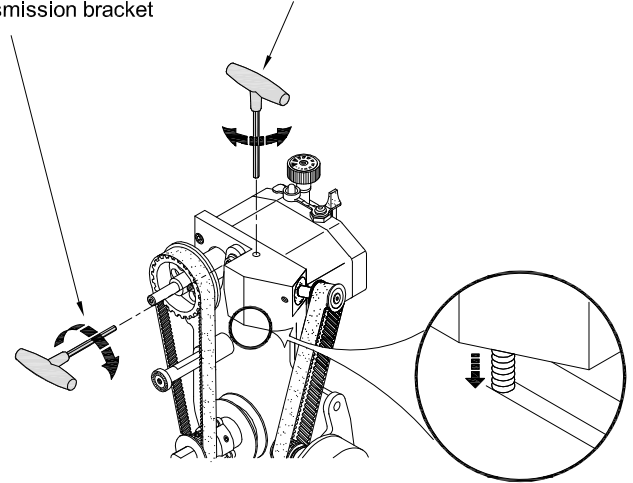

時規齒輪要成平行  
Timing gears must be parallel

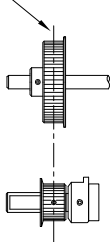

皮帶鬆緊度參考圖  
Reference for belt tension

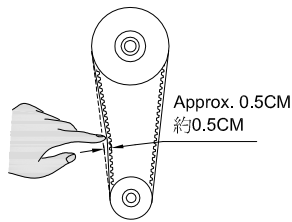

## 6 入力軸定位 Adjust input shaft position

變速機的紅線對齊入力軸紅線 ②後,上緊時規齒輪螺絲 ③  
Meet the both red line on transmission input shaft ②,  
tighten the timing gear screw ③.

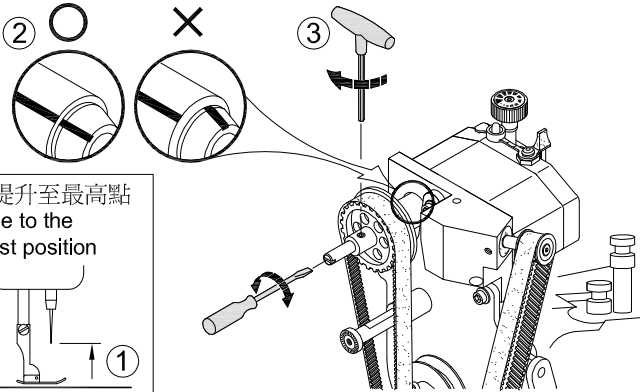

車針提升至最高點  
Needle to the  
toppest position

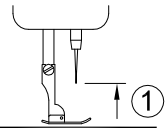

## 7 安裝皮帶護蓋 Install belt cover

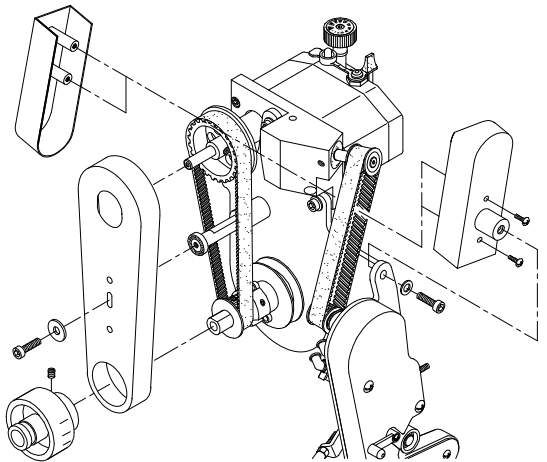

拖輪進,出操作  
Operation for inward and outward of belt puller

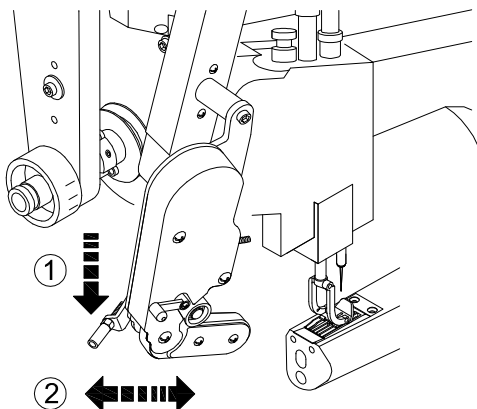

# 調整 SETTING

## 壓腳壓力調整:

安裝本皮帶式拖輪,需將壓腳壓力調輕減半(約6公斤)會使車縫更順暢,尤其是布料褲襠接縫的重疊處

Adjustment for presser foot pressure: When install the belt type puller, please adjust the presser foot pressure to be lesser to 50% (around 6 KGS) to easily sew over the lap seam in the crotch of trousers.

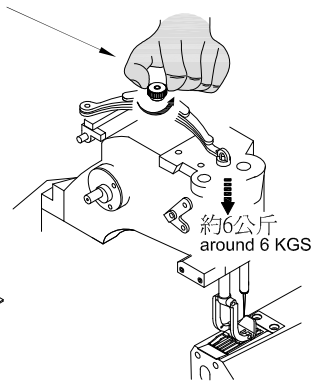
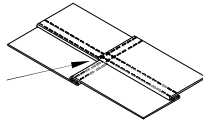

拉布皮帶的動作量應比送齒稍大,但差率太多時拉布皮帶則易磨損

The puller's feeding amount should be properly larger than feed dog's to procure even effect on sewn material. But if it is overmuch, either sewn material or pulling belt will be worn easily.

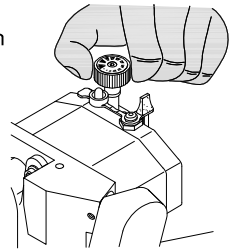
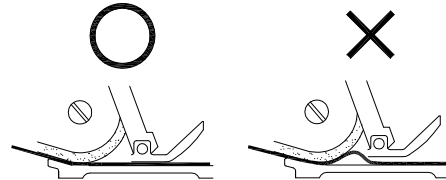

## PF-UB 管路圖 AIR HOSE PLUG DIAGRAM FOR PF-UB

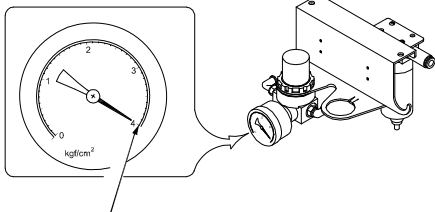

適當的空氣壓力最高是4公斤  
The maximum proper air pressure is 4 Kgf/cm<sup>2</sup>

空氣壓力調整愈高,拉布的力量就愈大,縫製就愈順暢,產能也會愈高,而皮帶受力愈大,就愈容易磨損

The higher air pressure, the stronger pulling power and higher production efficiency, but the belt will suffer more strength to be worn easily.

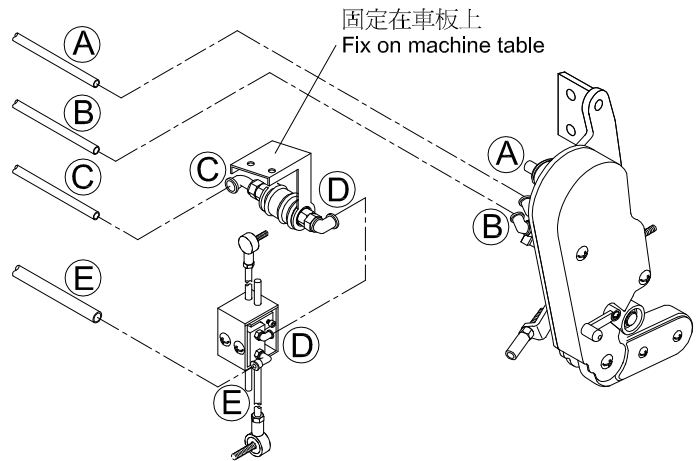

## PF-UB / EFV / AF 管路圖 AIR HOSE PLUG DIAGRAM FOR PF-UB / EFV / AF

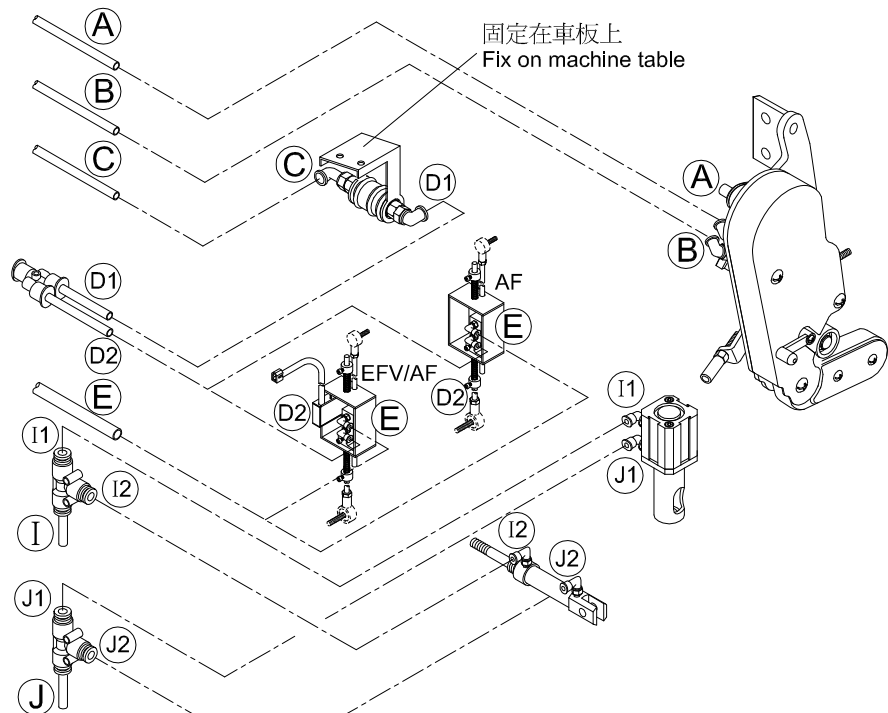
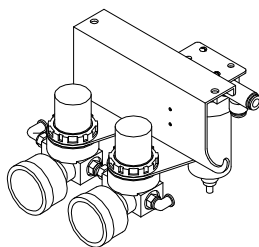

# AF 氣動壓腳提升裝置按裝說明 (選擇性配件) INSTALLATION GUIDE FOR AF (OPTIONAL PARTS)

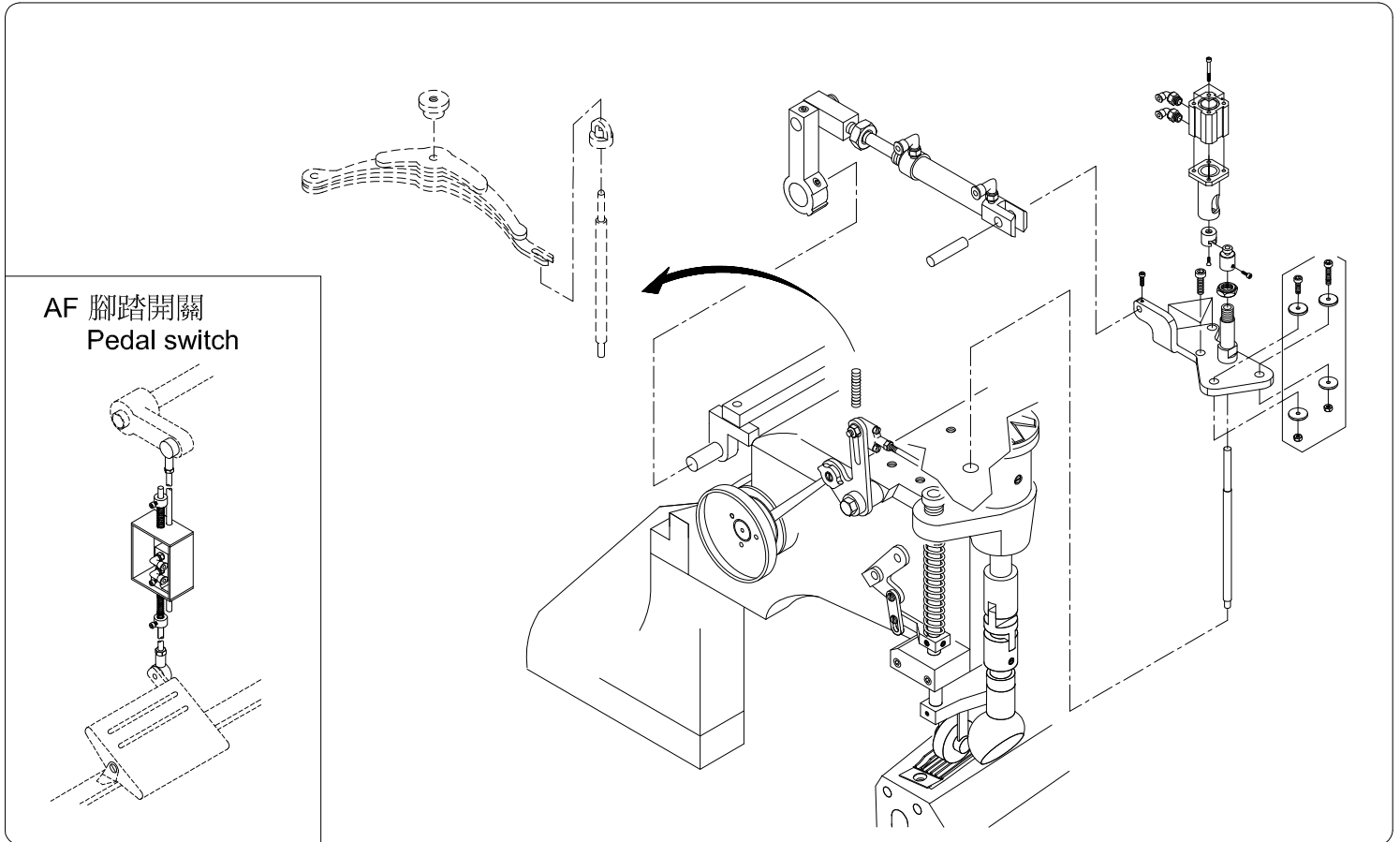

# AF 管路圖 (選擇性配件) AIR HOSE PLUG DIAGRAM FOR AF (OPTIONAL PARTS)

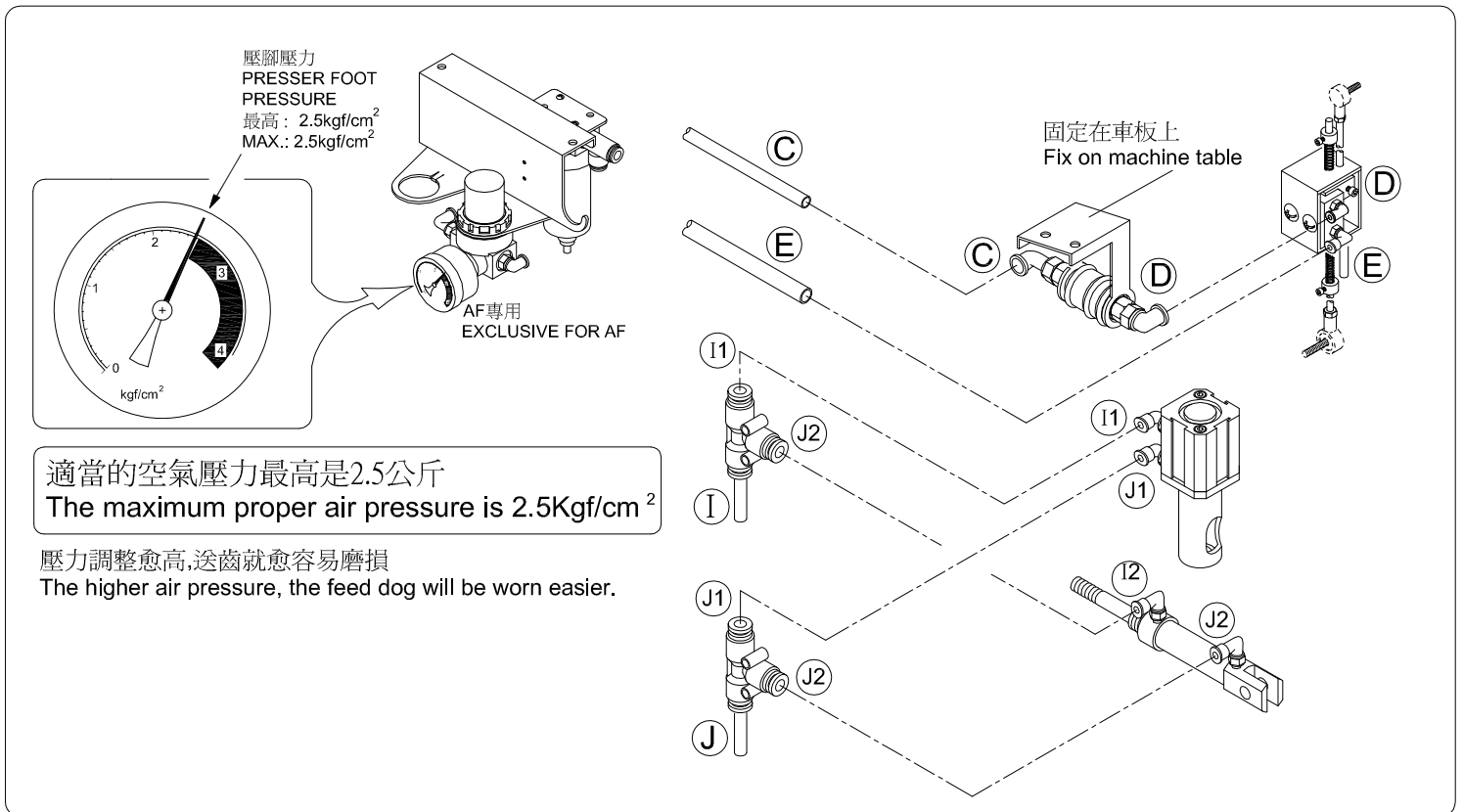

EFV 組合圖 (選擇性配件) THE COMBINATION OF EFV (OPTIONAL PARTS)

安裝EFV  
Install EFV

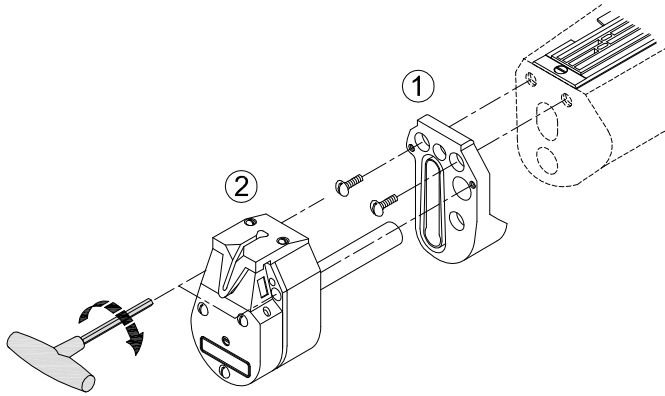

腳踏開關  
Pedal switch

EFV

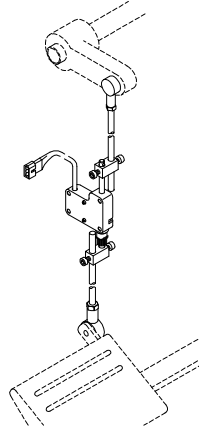

EFV/AF

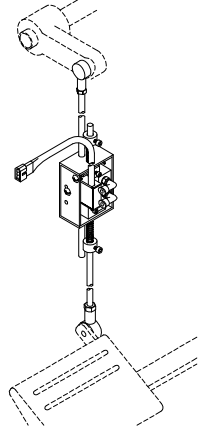

集屑袋  
Chain collection bag

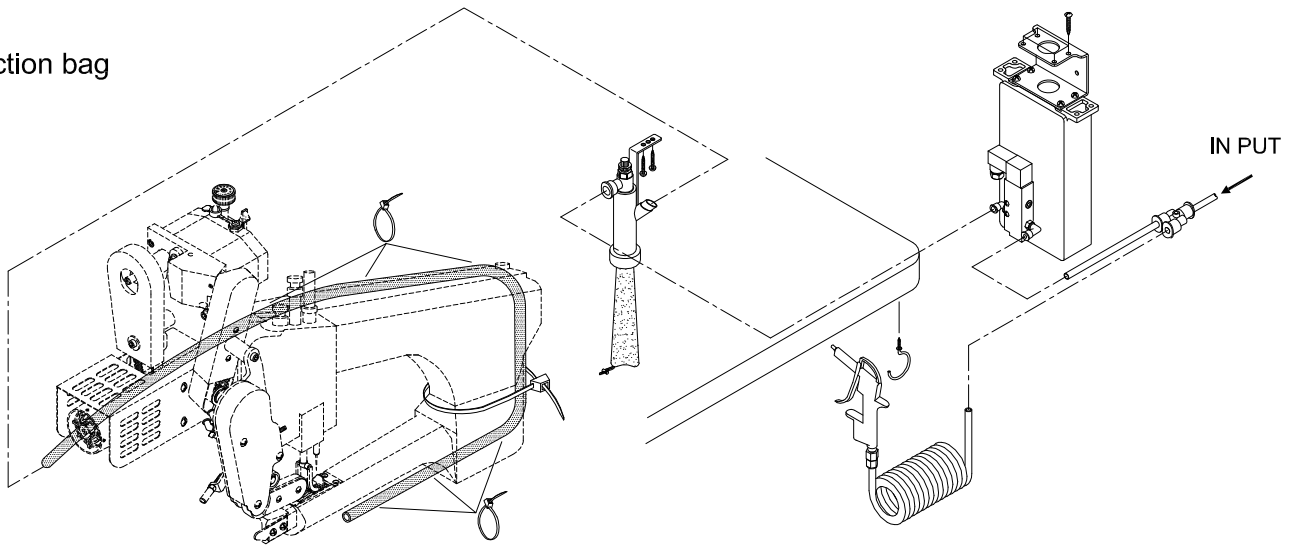

## EFV 管路圖 (選擇性配件) AIR HOSE PLUG DIAGRAM FOR EFV (OPTIONAL PARTS)

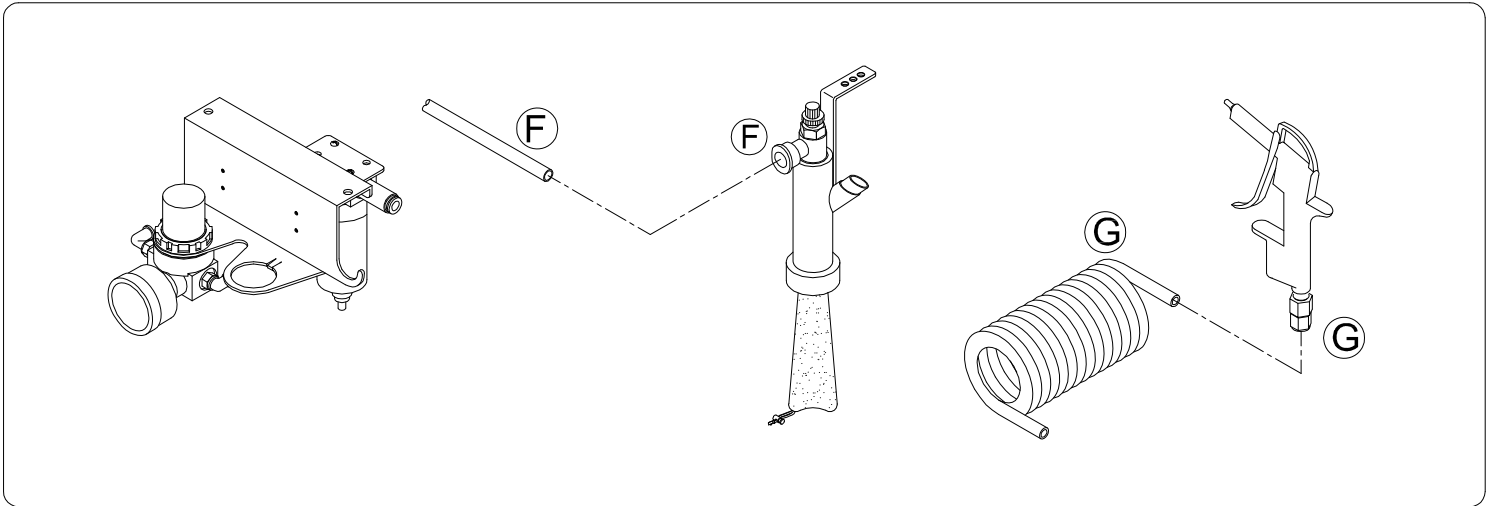

## EFV 自動切線接線圖 (選擇性配件) WIRING DIAGRAM FOR EFV CHAIN CUTTER (OPTIONAL PARTS)

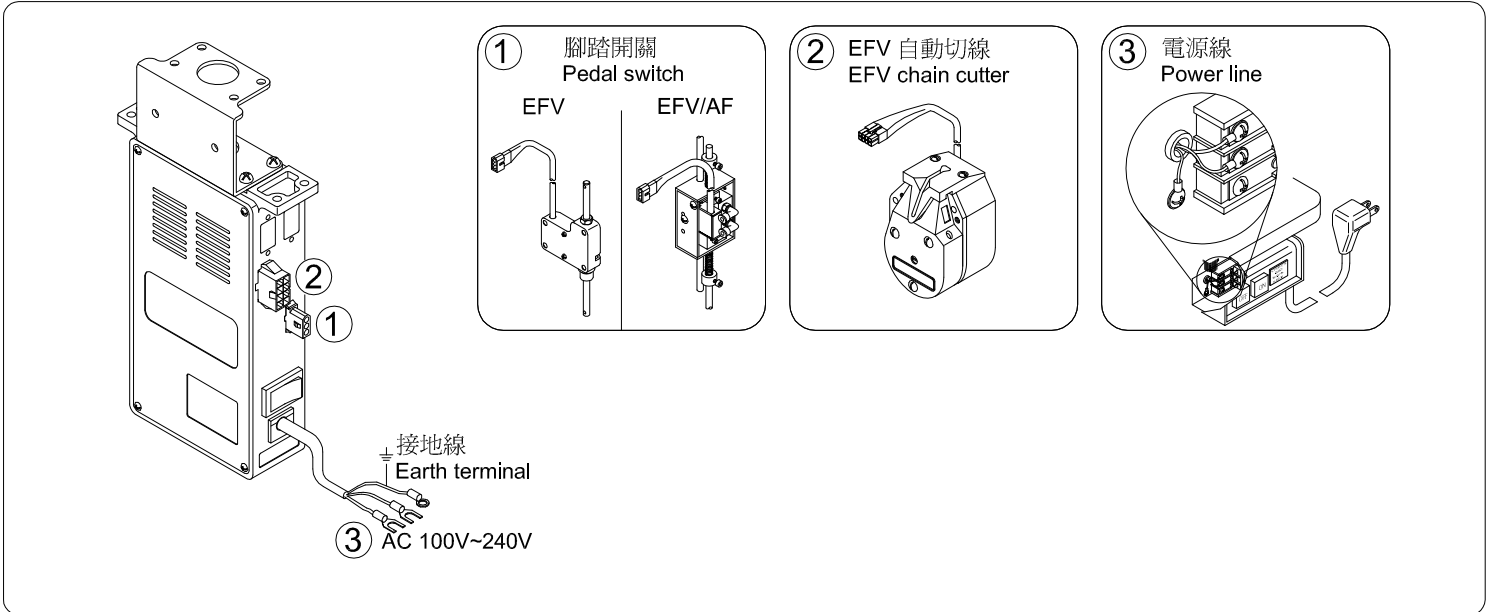

## 保養 MAINTENANCE

至少每週加油一次  
Please oil per week at least.

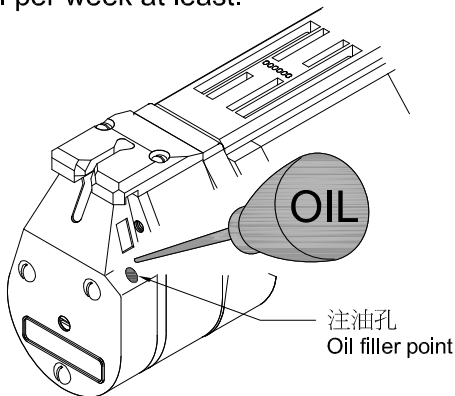

應每日及管道阻塞時吹氣清除保持管道暢通  
Please blow the pipe to clear obstructions  
everyday and when pipe is stuck.

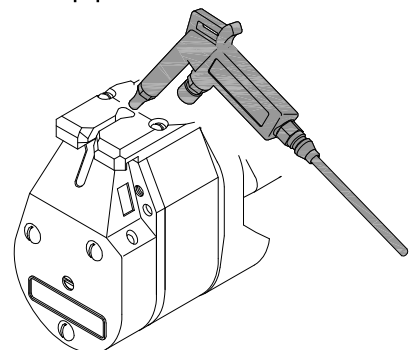



# PF-UB 零件圖 PARTS LIST FOR PF-UB

記號說明  
Mark description

- ❓ 選擇性配件,請告知直驅馬達廠牌機型
- Please indicate direct drive motor model No. for optional parts.

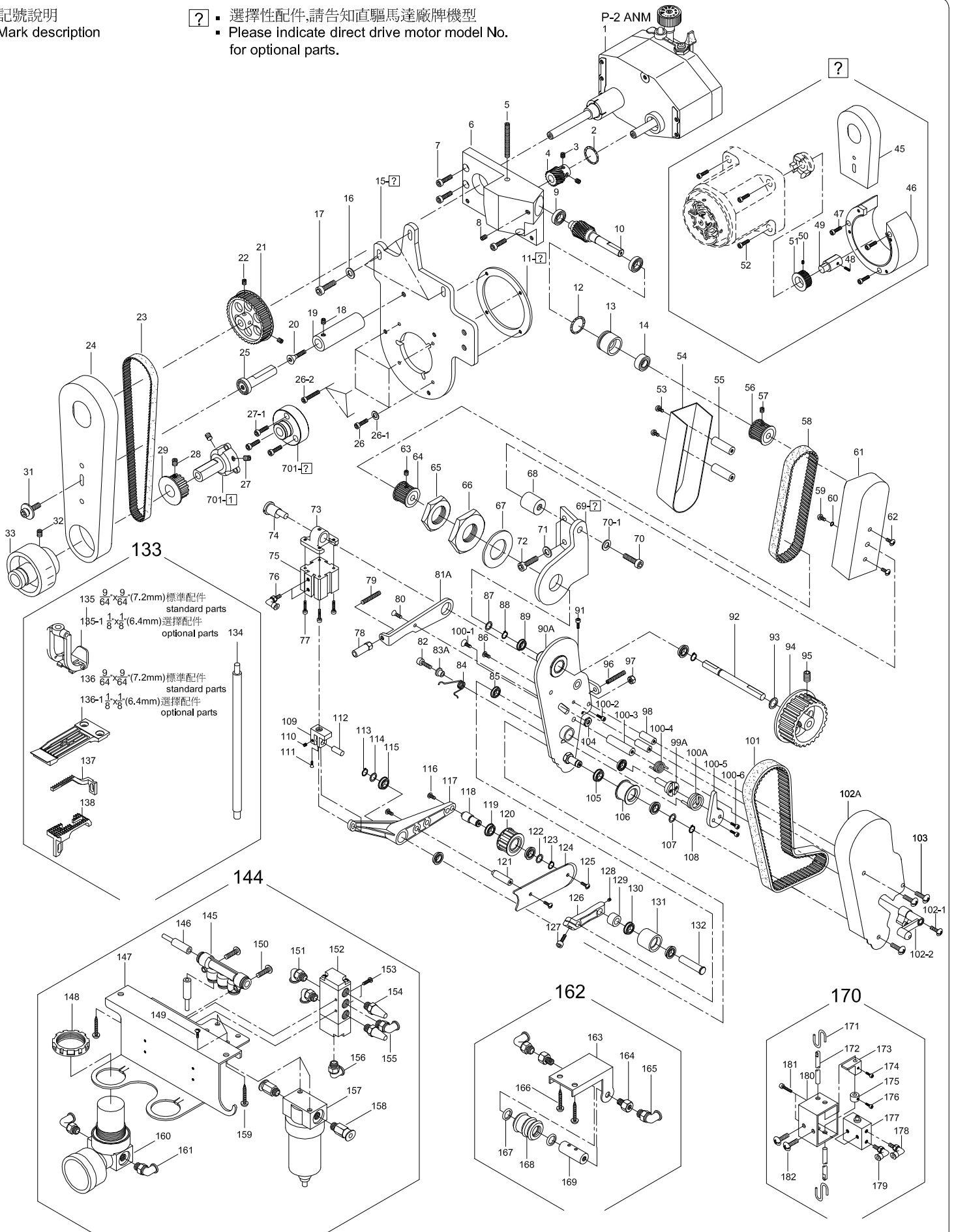

# EFV自動切線零件圖 (選擇性配件) PARTS LIST FOR EFV CHAIN CUTTER (OPTIONAL PARTS)

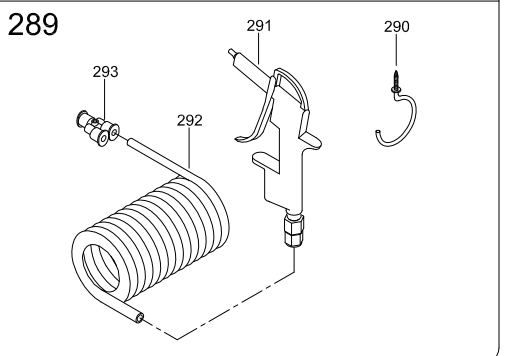
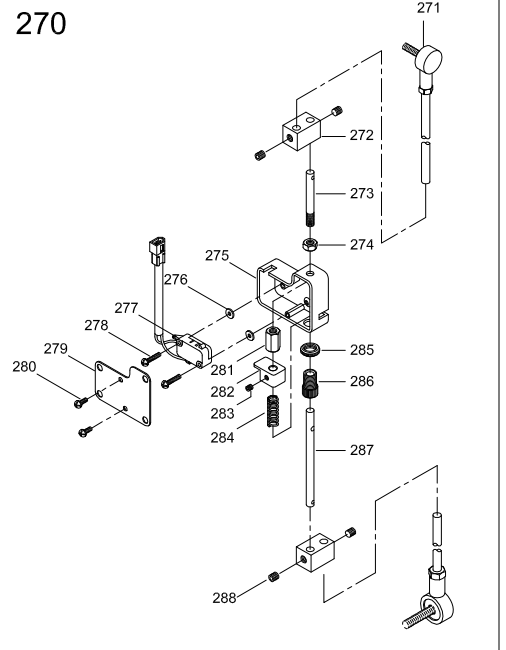
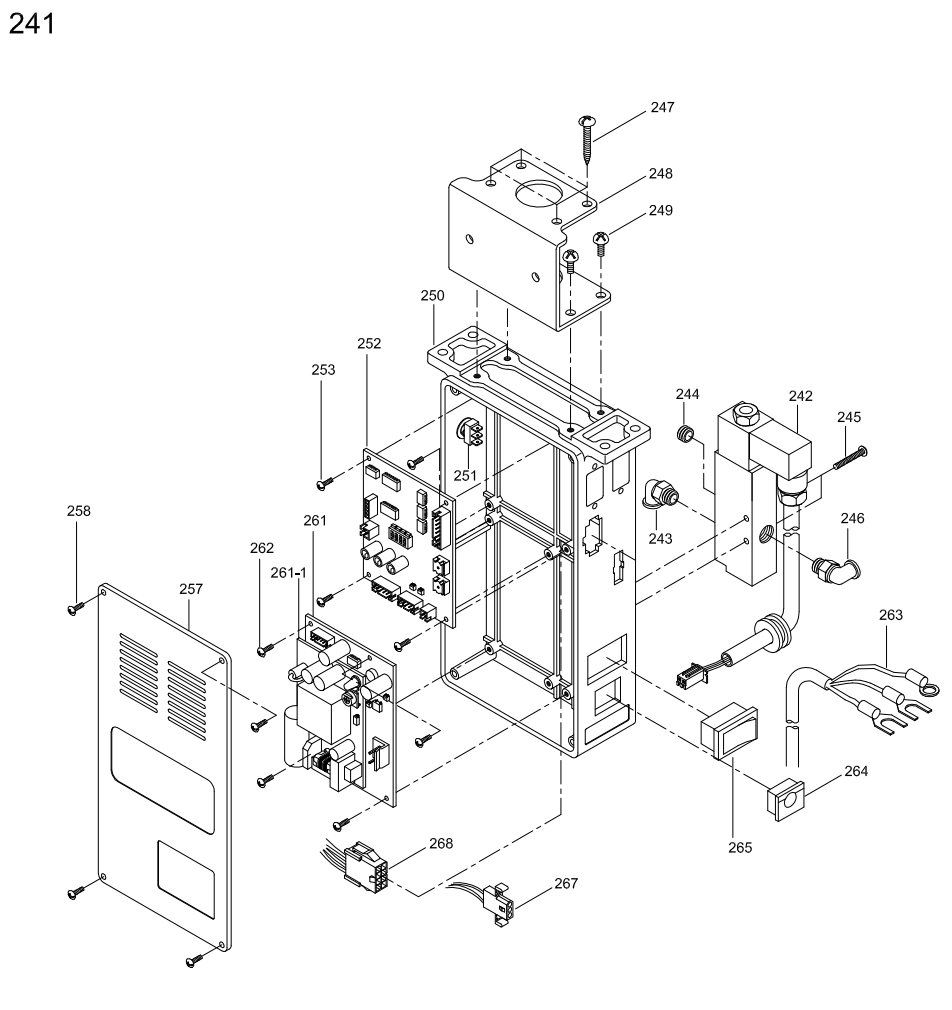
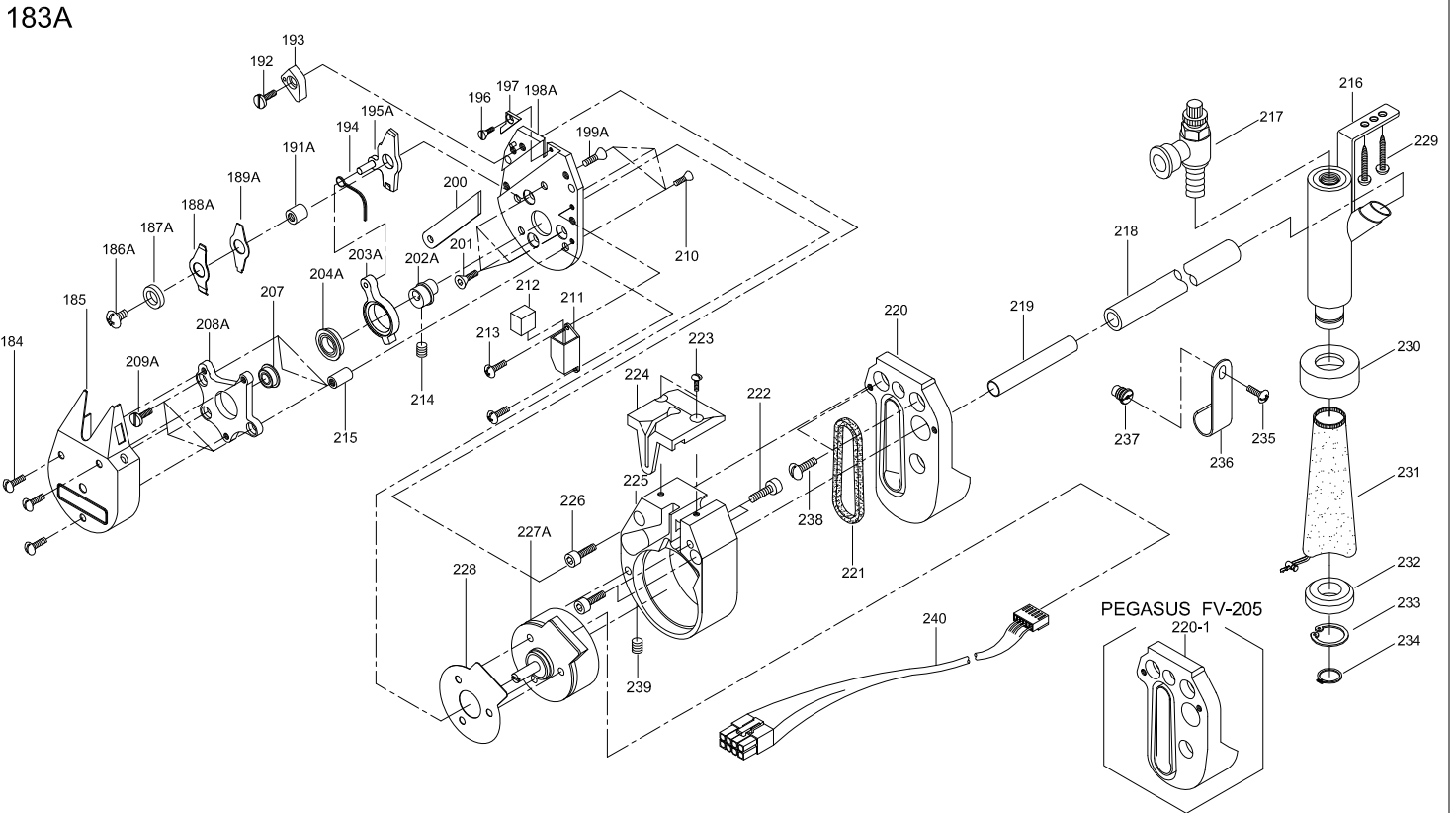

# AF壓腳提升零件圖 (選擇性配件)

# PARTS LIST FOR PNEUMATIC PRESS FOOT LIFTER(OPTIONAL PARTS)

記號說明  
Mark description

■ 選擇性配件  
■ Optional parts

294

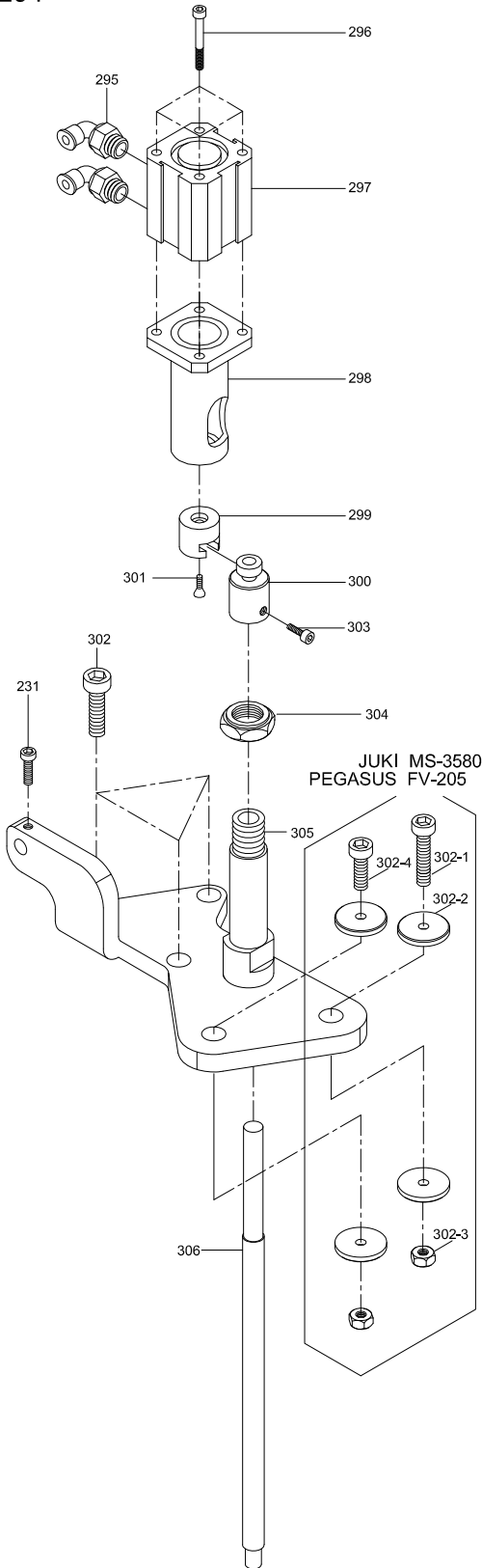

307

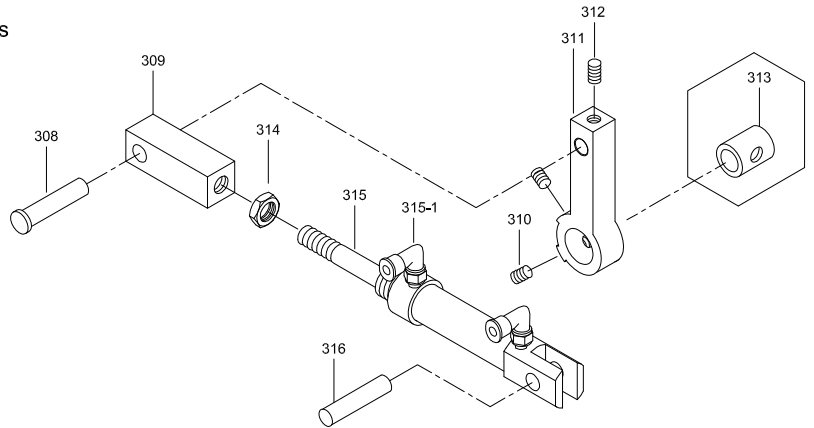

317

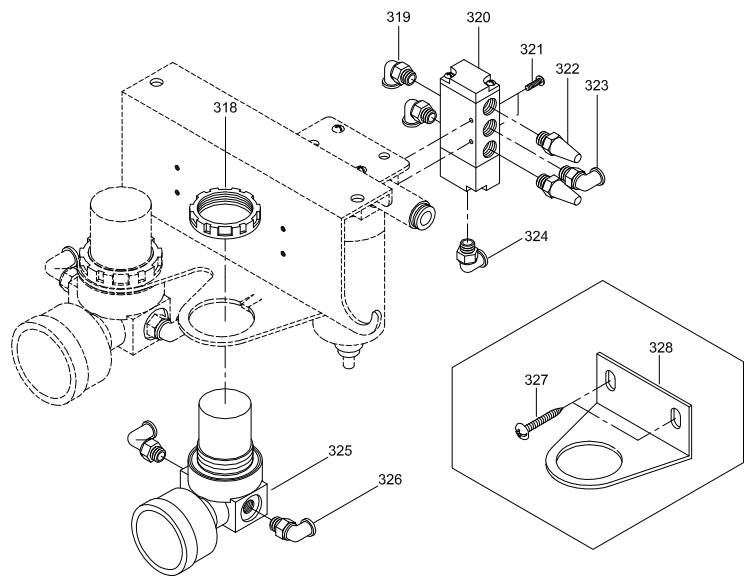

329

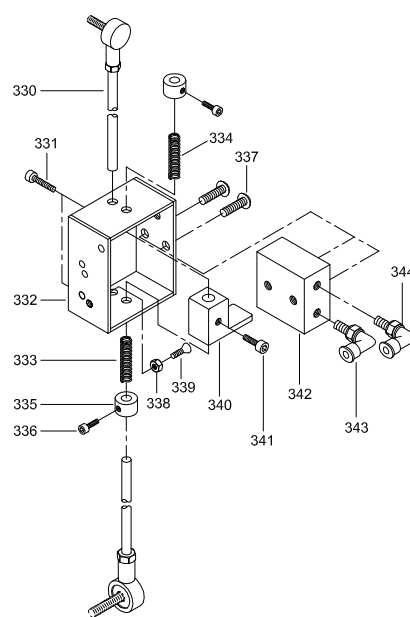

345 EFV/AF 專用  
EXCLUSIVE FOR EFV/AF

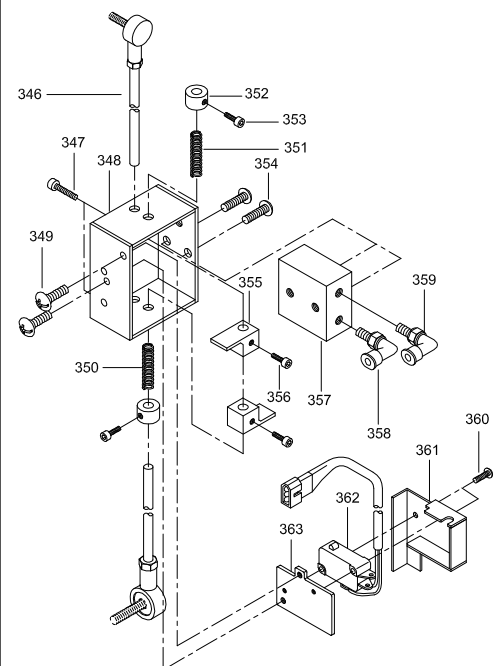

# PF-UB/EFV/AF



## 皮帶式拖輪安裝手冊

## THE INSTALLATION GUIDE BOOK

Unison Special 35800  
JUKI MS3580  
Pegasus FV205  
Kansai Sepcial SX6803

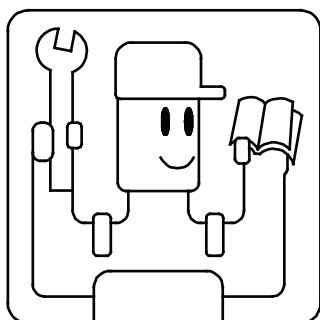
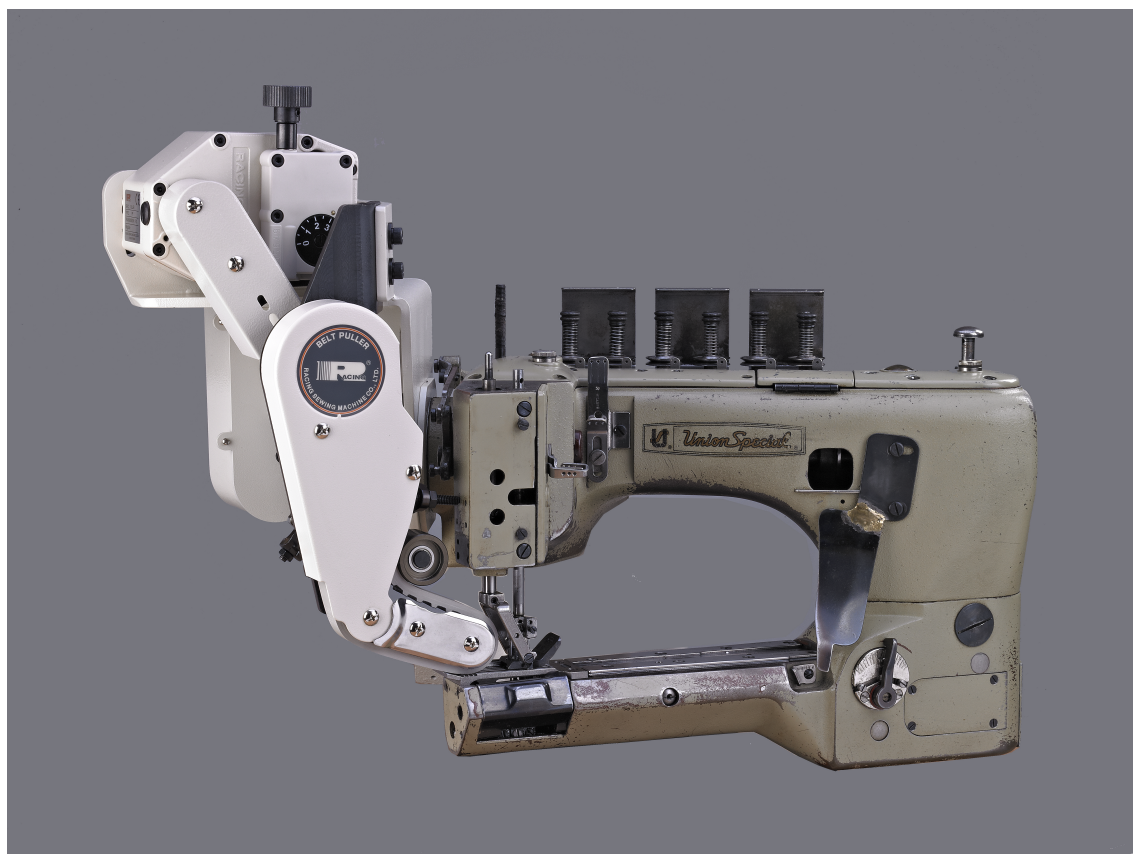

- 安裝前，請詳細閱讀安裝說明書
- PLEASE READ INSTRUCTIONS & ASSOCIATED DRAWINGS BEFORE INSTALLATION