

TCM.TCA-L25 / M45 / H50 組合圖  
THE COMBINATION OF TCM.TCA-L25 / M45 / H50

請依編號順序組合  
Please assemble the device according to the indicated numbers.

平床車  
Flatbed machine

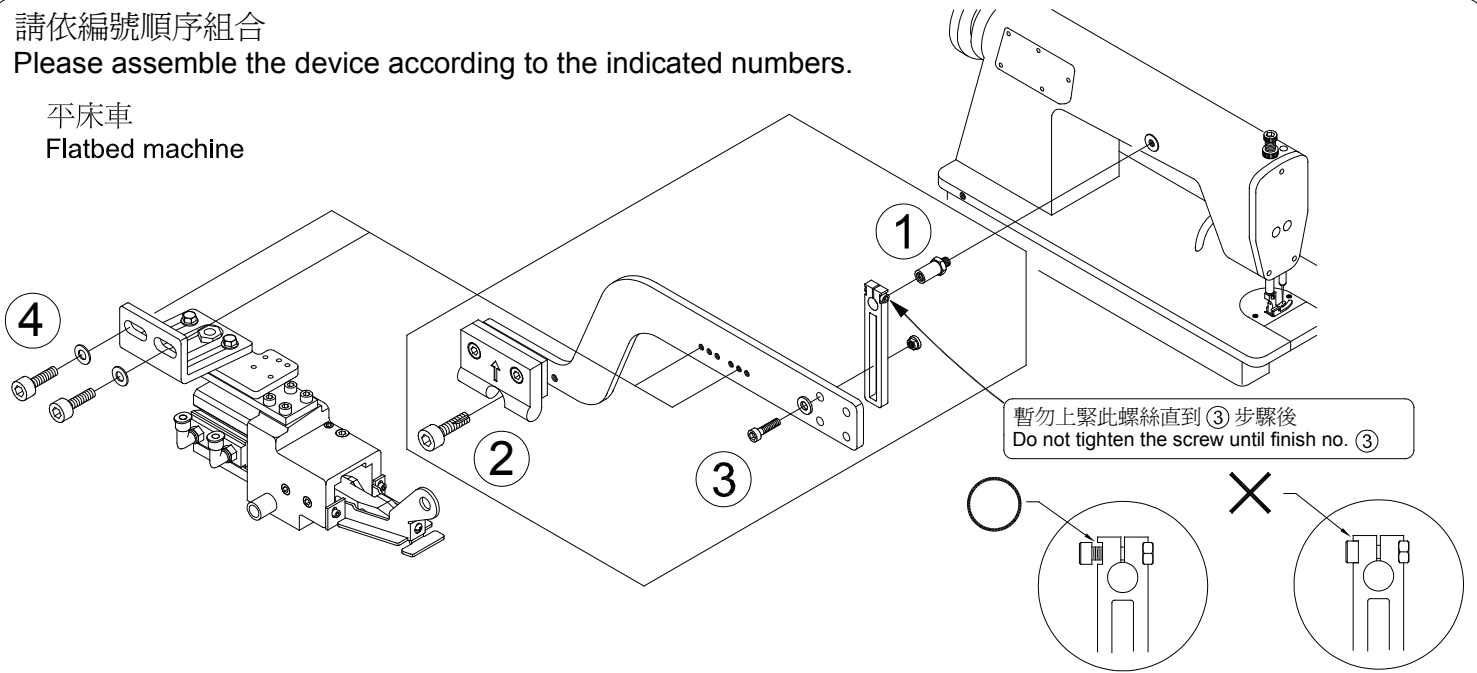

飾縫車  
Coverstitch machine

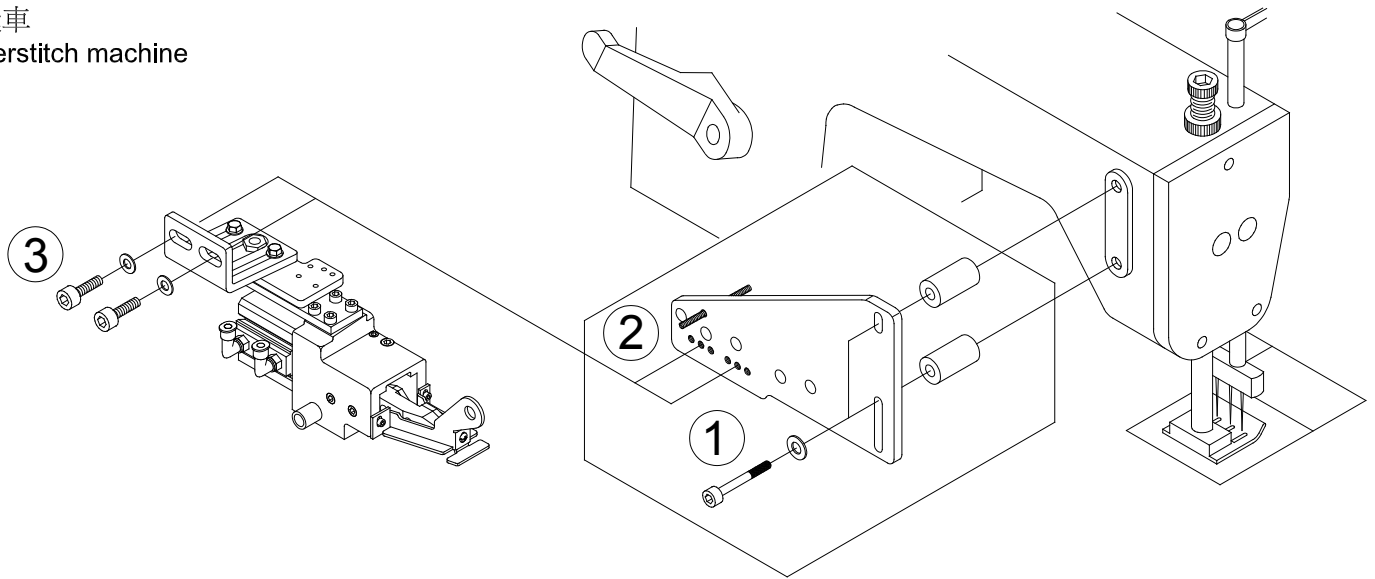

控制組  
CONTROL BOX

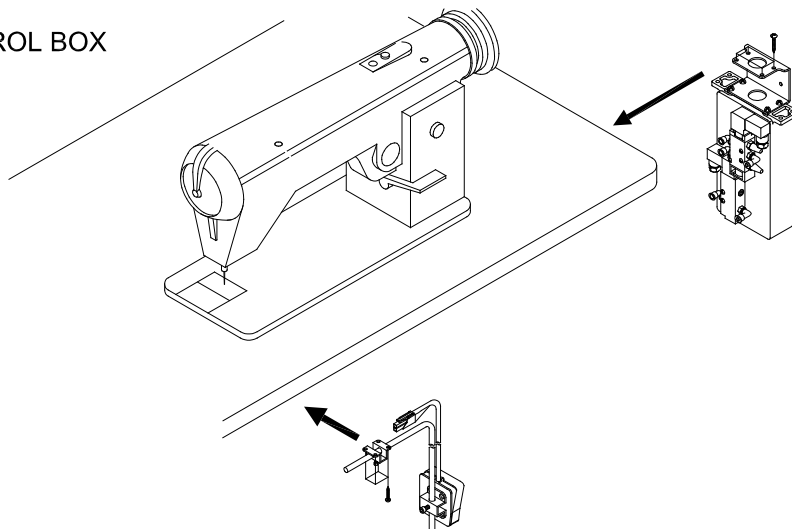

E6-2腳踏開關  
PEDAL SWITCH

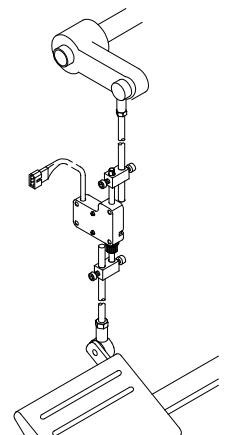

安裝前注意:

此切刀裝置的安裝位置或螺絲孔位置若與拉布裝置或其他裝置產生重疊或干涉時,不能同時使用,請自行設法加工固定

Please note before installation:

When install the TC device, Please relocate if device's location or the screw hole interferes or coincide with Puller or other devices. Otherwise please stop using TC device

基座可以上下前後及左右調整  
The base is allowed to move up, down, rear, front, right and left.

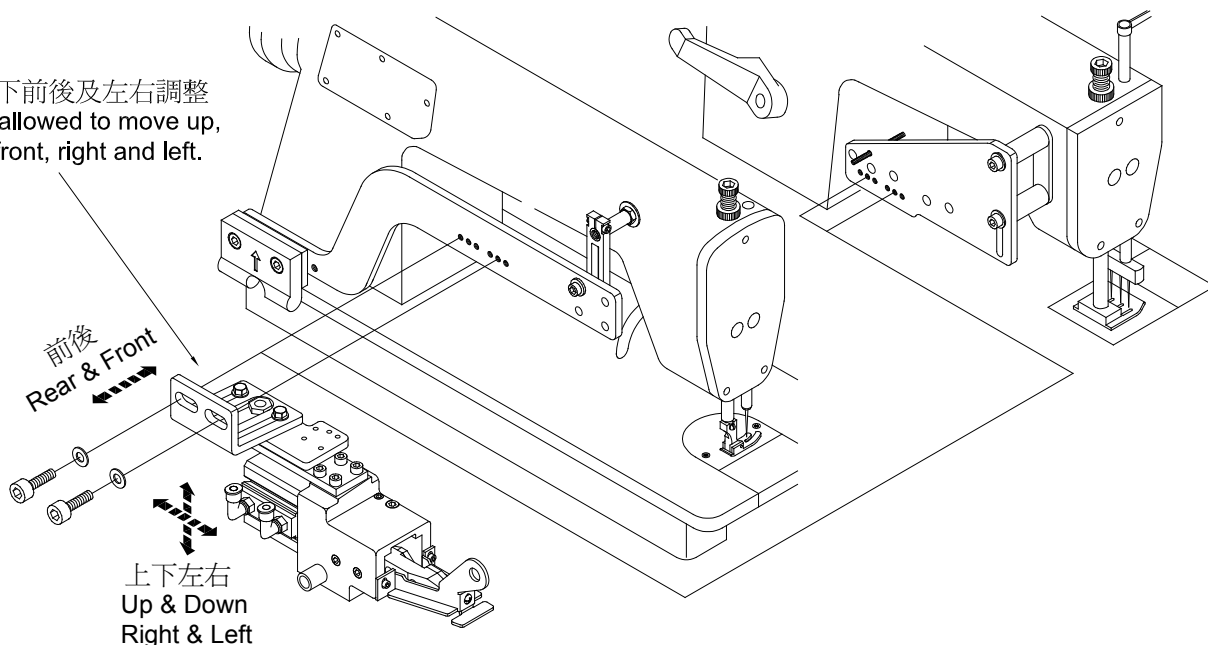

吹氣調整:

吹氣桿的位置及吹氣方向不對或風量太小時,布料會阻塞於壓布腳與切刀之間隙間

Air Jet Bar adjustment:

The material may be jammed at the gap between presser foot and cutter due to the improper location and angle of Air Jet or the weak air flow rate.

吹氣桿可以上下前後及左右調整  
The Air Jet Bar is allowed to move up, down, rear, front, right and left.

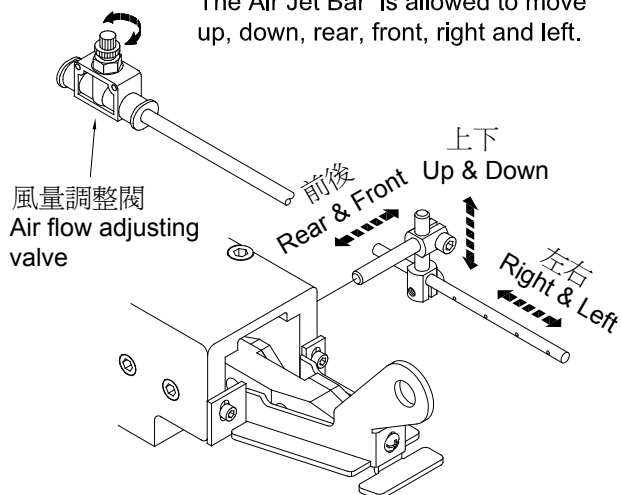

吹氣桿的位置 ① 應靠近壓布腳的後面略低於前端保護蓋  
吹氣口的方向約70°~80° ② 吹氣往上或下均不利送布的順暢

Location of Air Jet Bar ① should be just behind the presser foot and also lower than the safety cover of cutter.

The Angle of Air Jet should be about 70~80 degree ②. If the angle is too high or low, the sewing material may be jammed easily.

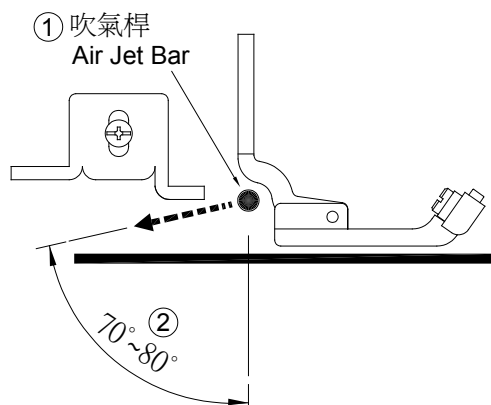

TCM / TCA 控制箱管路圖

AIR HOUSE PLUG DIAGRAM FOR TCM / TCA CONTROL BOX

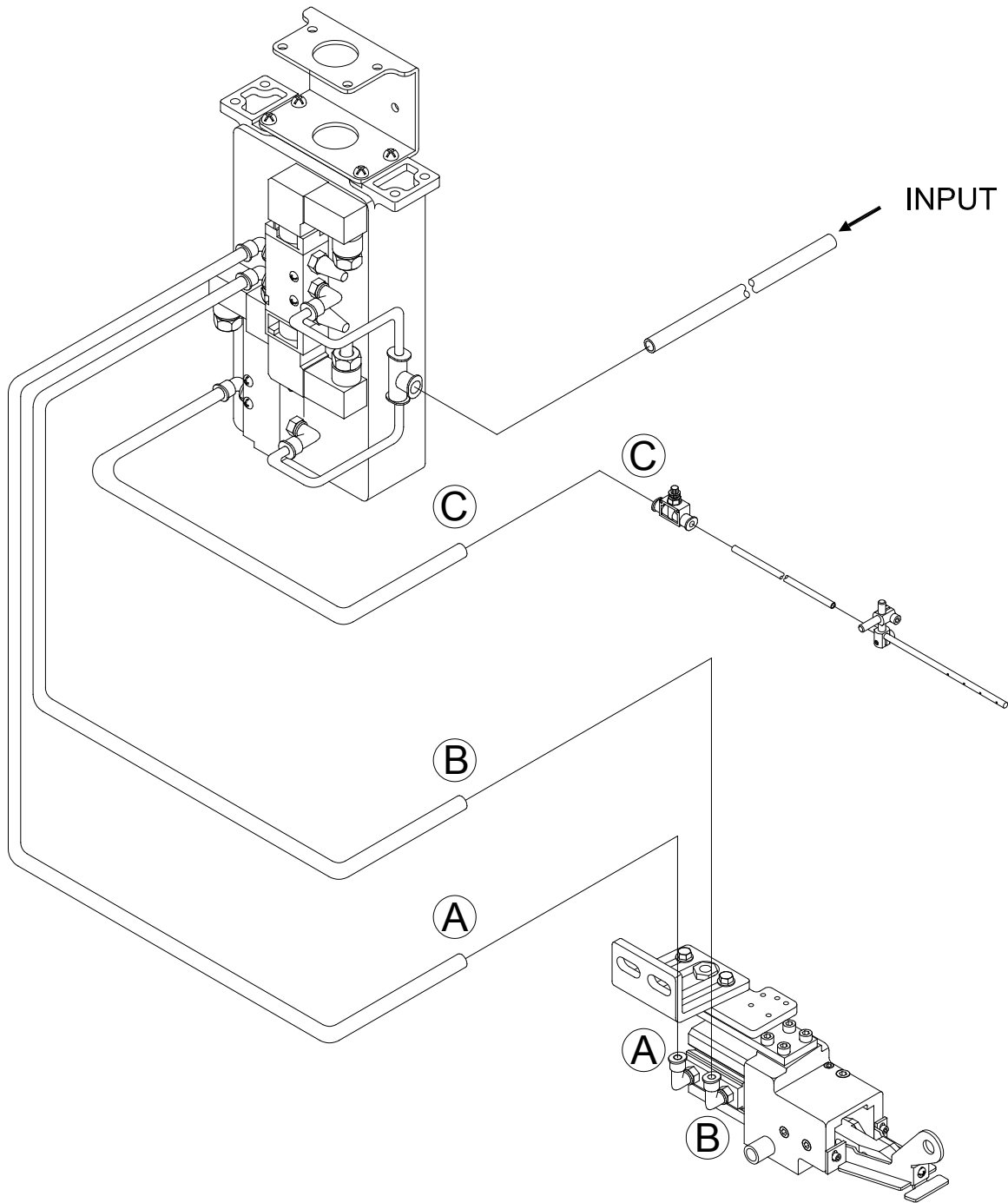

TCM 控制箱接線圖  
WIRING DIAGRAM FOR TCM CONTROL BOX

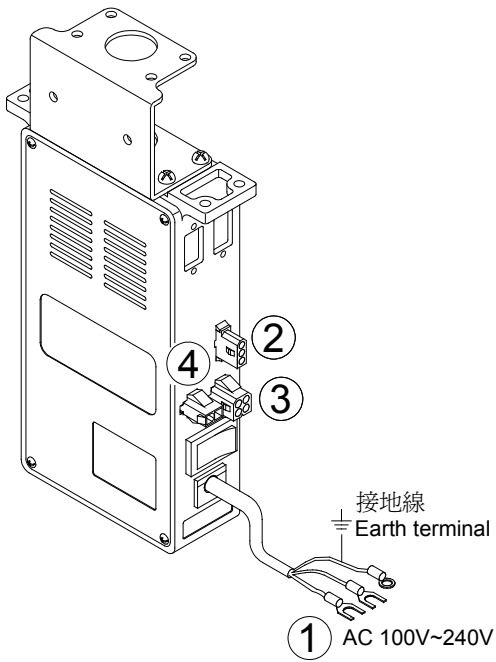

① 電源線  
Power line

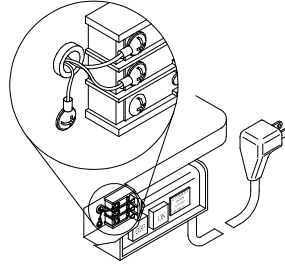

② E6-2腳踏開關  
Pedal switch

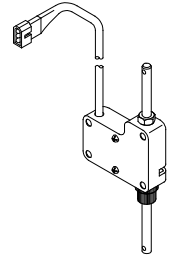

③ 電磁閥  
Valve

TCM.TCA-H50

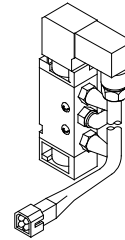

TCM.TCA-L25  
TCM.TCA-M45

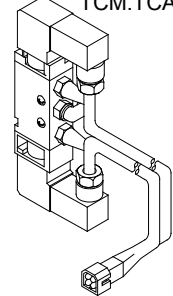

④ 膝動開關  
Knee switch

左手觸動開關  
Left manual switch  
(選擇性配件)  
(Optional parts)

右手觸動開關  
Right manual switch  
(選擇性配件)  
(Optional parts)

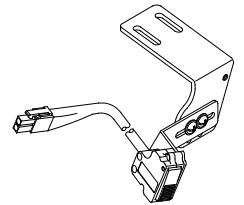
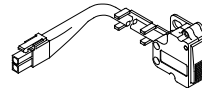
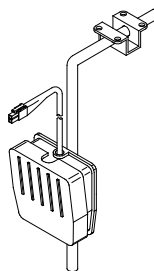

TCM.TCA-L25 / M45 / H50 零件圖  
PARTS LIST FOR TCM.TCA-L25 / M45 / H50

平床車專用  
Exclusive for flatbed machine

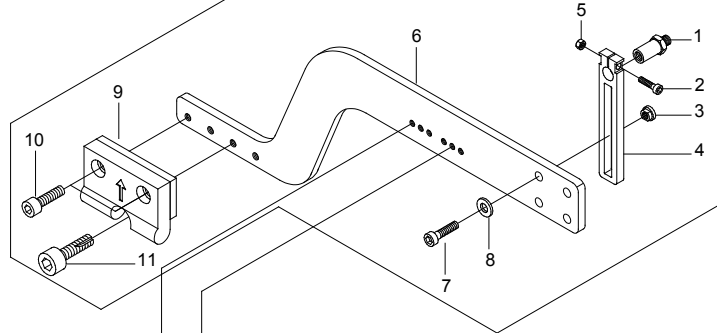

飾縫車專用  
Exclusive for coverstitch machine

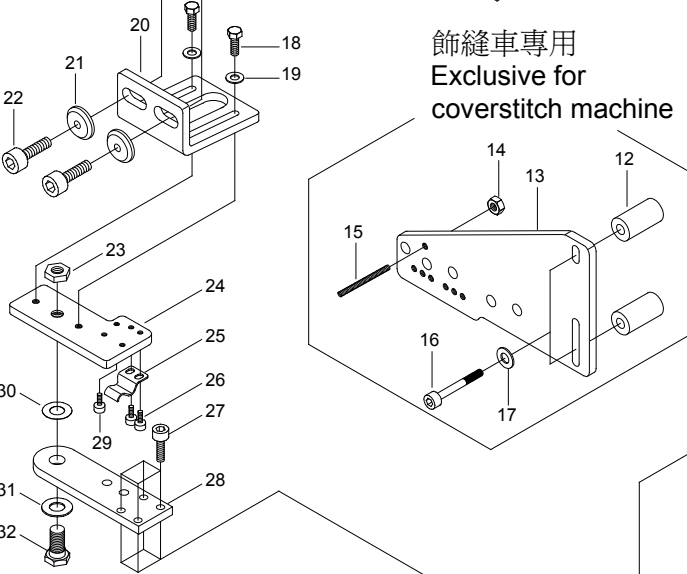

TCM.TCA-M45  
85

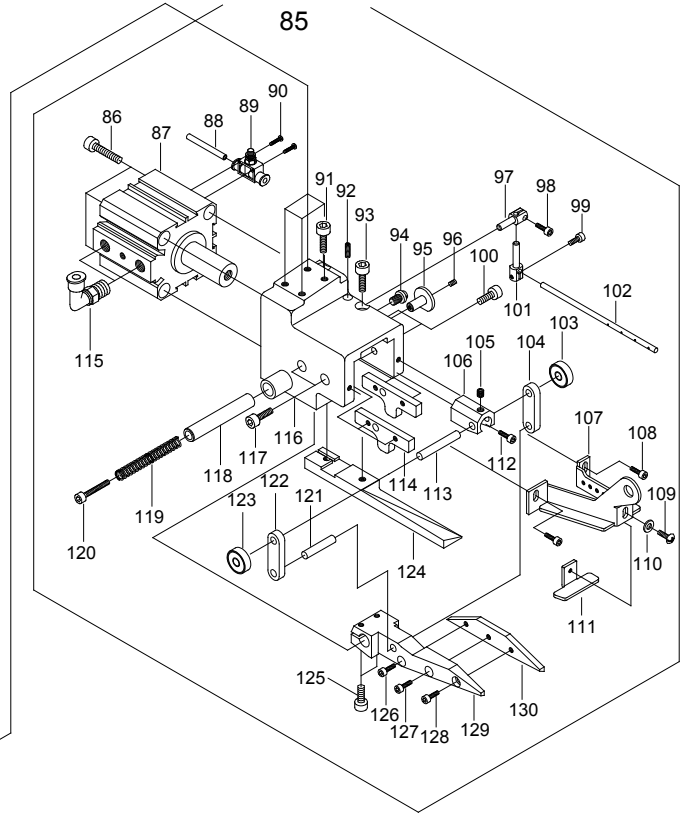

TCM.TCA-L25  
33

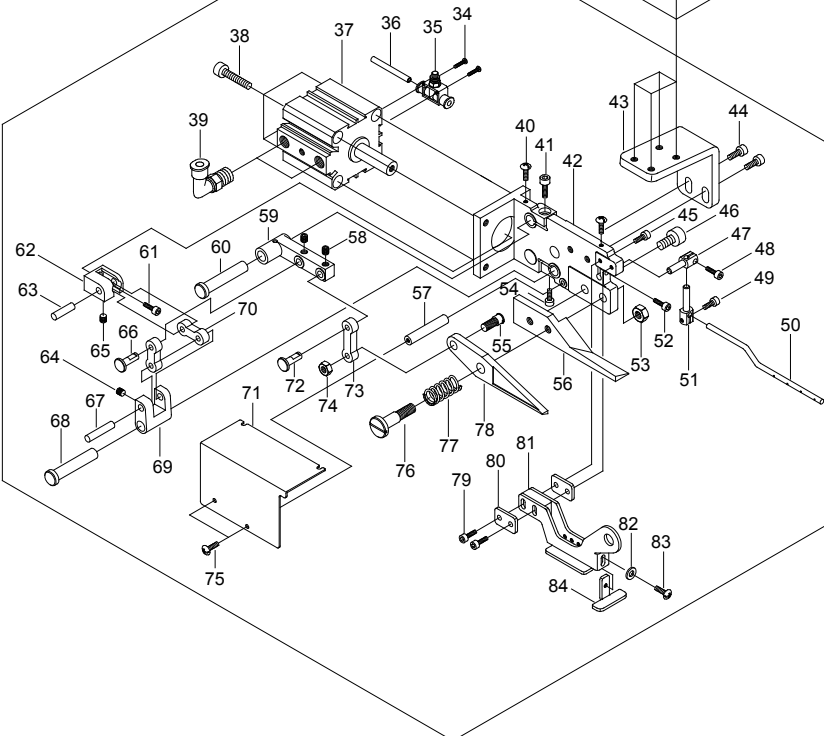

TCM.TCA-H50  
131

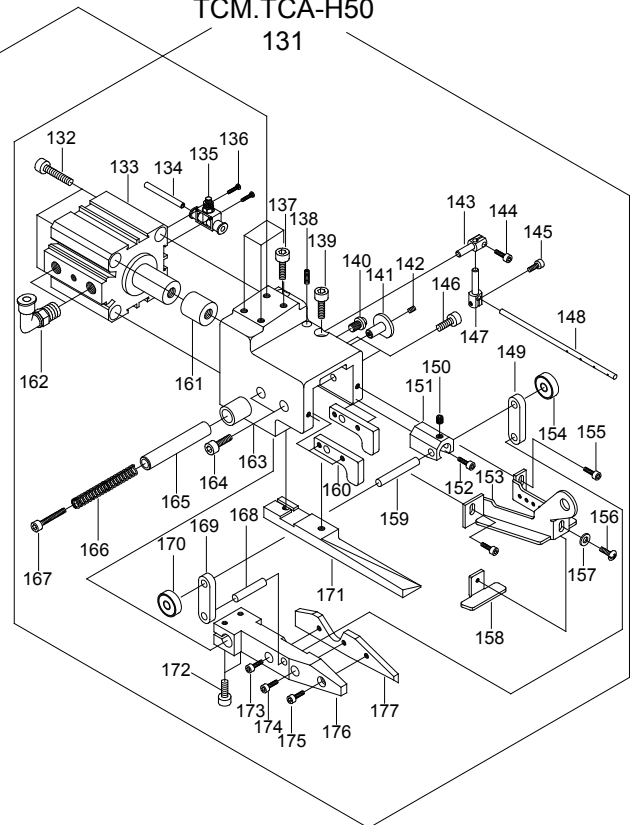

TCM-L25 / M45 / H50 零件圖  
PARTS LIST FOR TCM-L25 / M45 / H50

178

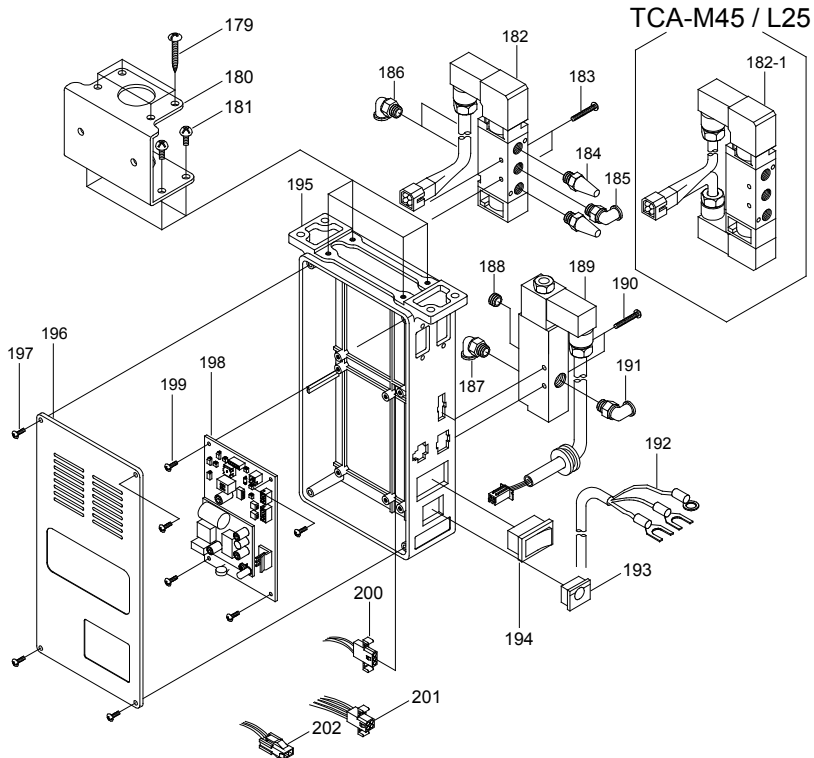

203

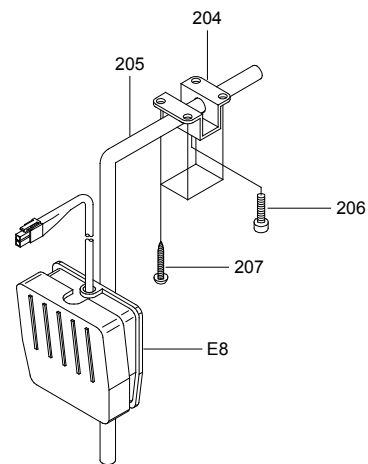

208

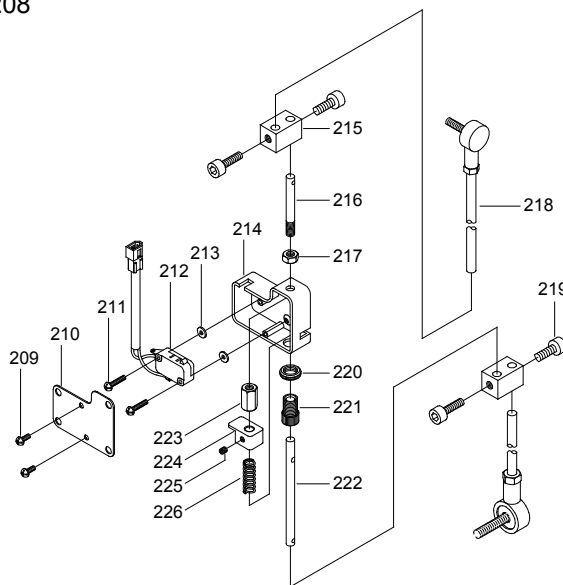

選擇性配件  
OPTIONAL PARTS

左手觸動開關  
Left manual switch  
227

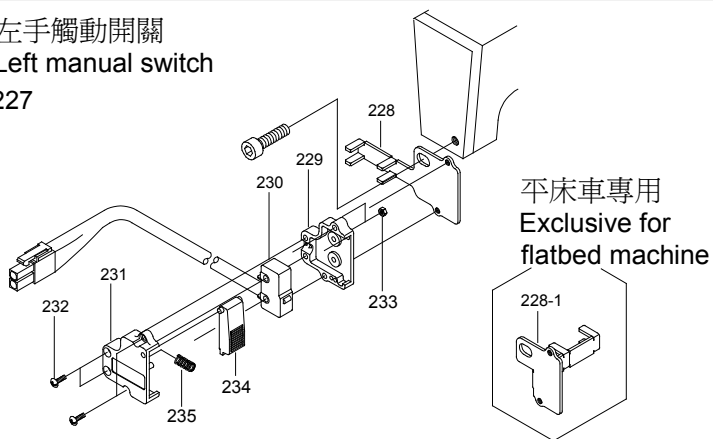

右手觸動開關  
Right manual switch  
236

