

M

UAS-H901

Electronic Lockstitch belt loop bar tacker

UAS-H902

Electronic Lockstitch eyelet button hole
end bar tacker

UAS-H903

Electronic Lockstitch pattern tacker

UAS-H906

Electronic Lockstitch eyelet bar tacker

UAS-H908

Electronic Lockstitch button sewer

UAS-H900D SERIES

Electronic Lockstitch bar tacker

OPERATION MANUAL

Unicorn®

Foreword





Thank you for using our Computerized Control System for Special Sewing Machine.

It is appreciated that you do read this manual carefully in order to operate the machine correctly and effectively. If the user operates the machine contrary to regulations herein, thus cause loss to user or third party, we will not take responsibility. Besides, you should keep this manual for future use. For any fault or problem of machine, please ask the professionals or the technicians authorized by us for repair service.







Safety Matters for Attention









1. Signs & Definitions of Safety Marks





This User's Manual and the Safety Marks printed on the products are to enable you to use this product correctly so as to be away from personal injury. The signs and definitions of Marks are shown in below:









 Danger	The incorrect operation due to negligence will cause the serious personal injury or even death.
 Caution	The incorrect operation due to negligence will cause the personal injury and the damage of mechanism.
	This kind of marks is "Matters for Attention", and the figure inside the triangle is the content for attention. (Exp. The left figure is "Watch Your Hand!")
	This kind of mark is "Forbidden".
	This kind of mark means "Must". The figure in the circle is the contents that have to be done. (Exp. The left figure is "Ground!")

2. Safety Matters for Attention

 Danger	
	For opening the control box, please turn off the power and take away the plug from socket firstly, and then wait for at least 5 minutes before opening the control box. Touching the part with high voltage will cause the person injury.
 Caution	
Usage Environment	
	Try not to use this sewing machine near the sources of strong disturbance like high-frequency welding machine. The source of strong disturbance will affect the normal operation of the sewing machine.
	The voltage fluctuation shall be within 20% of the rated voltage. The large fluctuation of voltage will affect the normal operations of sewing machine, Therefore a voltage regulator is needed in that situation.
	Working temperature: 5°C~35°C. The operation of the sewing machine will be affected by environment with

	temperature beyond the above range.
	Relative Humidity: 45%~85%(No dew inside the machine), or the operation of sewing machine will be affected.
	The supply of compressed gas shall be over the consumption required by the sewing machine. The insufficient supply of compressed gas will lead to the abnormal action of sewing machine.
	In case of thunder, lightning or storm, please turn off the power and pull plug out the socket. Because these will have influence on the operation of sewing machine.
Installation	
	Please ask the trained technicians to install the sewing machine.
	Don't connect machine to power supply until the installation is finished. Otherwise the action of sewing machine may cause personal injury once the start switch is pressed at that situation by mistake.
	When you tilt or erect the head of sewing machine, please use both of your hand in that operation. And never press the sewing machine with strength. If the sewing machine loses its balance, it will fall into floor thus causes the personal injury or mechanical damage.
	Grounding is a must. If the grounding cable is not fixed, it may cause the electric-shock and mis-operation of machine
	The entire cables shall be fixed with a distance at 25mm away from the moving component at least. By the way, don't excessively bend or tightly fixed the cable with nails or clamps, or it may cause the fire or electric shock.
	Please add security cover on the machine head.

Sewing	
	This sewing machine can only be used by the trained staff.
	This sewing machine has no other usages but the sewing.
	When operating the sewing machine, please remember to put on the glasses. Otherwise, the broken needle will cause the personal injury in case the needle is broken.
	At following circumstances, please cut off the power at once so as to avoid the personal injury caused by the mis-operation of start switch: 1.Threading on needles; 2. Replacement of needles; 3. The sewing machine is left unused or beyond supervision

	At working, don't touch or lean anything on the moving components, because both of the above behaviors will cause the personal injury or the damage of the sewing machine.
	During working, if the mis-operation happens or the abnormal noise or smell is found at the sewing machine, user shall cut off the power at once, and then contact the trained technicians or the supplier of that machine for solution.
	For any trouble, please contact the trained technicians or the supplier of that machine.
Maintenance & Inspection	
	Only can the trained technicians perform the repair, maintenance and inspection of this sewing machine.
	For the repair, maintenance and inspection of the electrical component, please contact the professionals at the manufacturer of control system in time.
	At following circumstances, please cut off the power and pull off the plug at once so as to avoid the personal injury caused by the mis-operation of start switch: 1.Repair, adjustment and inspection ; 2.Replacement of the component like curve needle, knife and so on
	Before the inspection, adjustment or repair of any gas-driven devices, user shall cut off the gas supply till the pressure indicator falls to 0.
	When adjusting the devices needing the power supply and gas supply, users can't be too careful to follow the entire Safety Matters for Attention.
	If the sewing machine damages due to the unauthorized modification, our company will not be responsible for it.

Contents

1. General Instruction	1
1.1 Specifications of UAS-H900D _{SERIES}	1
1.2 Corresponding Machine Type	2
1.3 Input Mode	2
1.4 Display Method.....	2
1.5 Arrangement of the Panel.....	2
1.6 Standardization.....	2
1.7 Operation Mode	2
2. Operation Instruction	3
2.1 Instructions of the Panel.....	3
2.2 Installing the Main Motor	4
2.3 Test Mode.....	6
2.3.1 CP-1 (Input Signal Check)	8
2.3.2 CP-2 (Origin Retrieval).....	10
2.3.3 CP-3 (Continuous Operation).....	10
2.3.4 CP-4 (Revolution Movement).....	11
2.3.5 CP-6 (Presser and Trimming Motor / Origin Sensor Check)	12
2.3.6 CP-7 (Thread Clamp Motor / Origin Sensor Check).....	13
2.4 Operation of the Sewing Machine (Basic)	14
2.4.1 Item Data Setting.....	14
2.4.2 Checking the Contour of a Sewing Pattern	16
2.4.3 Sewing.....	17
2.4.4 Change to Other Sewing Pattern	18
2.4.5 Winding a Bobbin.....	18
2.4.6 Thread Clamp Device.....	19
2.4.7 Bobbin Thread Counter	21
2.4.8 Temporary Stop	21
2.4.9 Setting the Pattern Thread Tension.....	22
2.4.10 Table of the Standard Patterns	22
2.5 Operations of P Pattern and C Pattern.....	24
2.5.1 Perform Sewing Using the Pattern Key ()	24
2.5.2 Perform Sewing Using the Combination Function	28
2.6 How to Use the Memory Switch (User Class)	31
2.6.1 Start and Change of the Memory Switch	31
2.6.2 Example of the Memory Switch Setting	32
2.6.3 Table of Functions of the User Class Memory Switch.....	36
3. Memory Switch (Service Class)	40
3.1 Start and Change of the Memory Switch (Service Class)	40
3.2 Table of Functions of the Service Class Memory Switch	40
3.3 Restore Default Setting	41

4. Lockstitch Button Sewing Function	45
4.1 Lockstitch Button Sewing Function Setting.....	45
4.2 Table of the Lockstitch Button Sewing Patterns	46
5. Update the Pattern Data by USB Flash.....	48
5.1 Pattern Data Update	48
6 Appendix 1	52
6.1 Error List	52
7 Appendix 2	55
7.1 Installation Size of Control Box.....	55
7.2 Installation Size of Operation Box	56
7.3 Diagram of Connection of the External Cable and Control Box.....	57
7.4 UAS-H900D _{SERIES} Control System Diagram	58

1. General Instruction

1.1 Specifications of UAS-H900D_{SERIES}

No.	TYPE ITEM	UAS-H900D _{SERIES}
1	Purpose	Bartacking / Button Lockstitch
2	Sewing Area	X(lateral) direction 40mm × Y(longitudinal) direction 30mm
3	MAX. Sewing Speed	3000rpm (when sewing pitches are less than 4.5mm in X-direction and 3.5mm Y-direction)
4	Stitch Length	0.1mm – 10.0mm (adjustable in 0.1mm step)
5	Feed Motion of Work Clamp Foot	Intermittent Feed(2-draft drive by stepping motor)
6	Needle Bar Stroke	41.2mm
7	Needle	DP×5, DP×17
8	Type of driving Work Clamp Foot	Driven by pulse stepping motor
9	Lift of Work Clamp Foot	13mm (Standard), Max. 17mm
10	Total Number of Standard Patterns	50
11	Wiper Type	To work together with Work Clamp Foot driven by Stepping Motor
12	Thread Clamp	Standard : 0
13	Needle Thread Tension	Electrical Thread Tension Release
14	Shuttle	Standard Semi-rotary Hook (oil wick lubrication)
15	Lubricating Method	Rotary Part: Lubricate with minimum amount
16	Lubricating Oil (Liquid)	Ordinary Sewing Machine Lubricating Oil (Liquid)
17	Grease	Ordinary Sewing Machine Grease
18	Data Recording	Flash Memory
19	Enlarging/Reducing Facility	20%~200%(1% step) in X direction and Y direction respectively
20	Enlarging/Reducing Method	By increasing/decreasing the stitch length
21	Max. Sewing Speed Limitation	400-3000rpm (100rpm step)
22	Pattern Selection	Specifying Pattern No. Type(1-200)
23	Bobbin Thread Counter	Up/Down Type (0 – 9999)
24	Sewing Machine Motor	500W Compact AC Servomotor (Direct Drive)

25	Dimensions	263mm×153mm×212mm
26	Weight	10 Kg
27	Power Consumption	600W
28	Operation Temperature Range	5°C - 40°C
29	Operation Humidity Range	35% - 85% (No Dew Condensation)
30	Line Voltage	Single Phrase AC 220V ± 10%; 50-60Hz

※ Reduce the MAX. Sewing Speed in accordance with the sewing conditions.

1.2 Corresponding Machine Type

UAS-H900D_{SERIES} Bartacking Machine

1.3 Input Mode

Use keys to input.

1.4 Display Method

Use 8-bit segment LED Display Module and LEDs to display all the information.

1.5 Arrangement of the Panel

The quadrate Panel can be divided into two parts, the display part and the operation part. There are 5 8-bit segment LED Display Module and 9 LEDs on the display part, and 11 keys on the operation part. For details, refer to 【2.1 Instructions of the Panel】.

1.6 Standardization

The function keys use standard icons recognized by the globe. Image is an international language that can be understood by any nation.

1.7 Operation Mode

Function keys include READY key, RESET key, MODE key, SELECTION key, etc. See operation instruction for detailed operating methods.

2. Operation Instruction

2.1 Instructions of the Panel

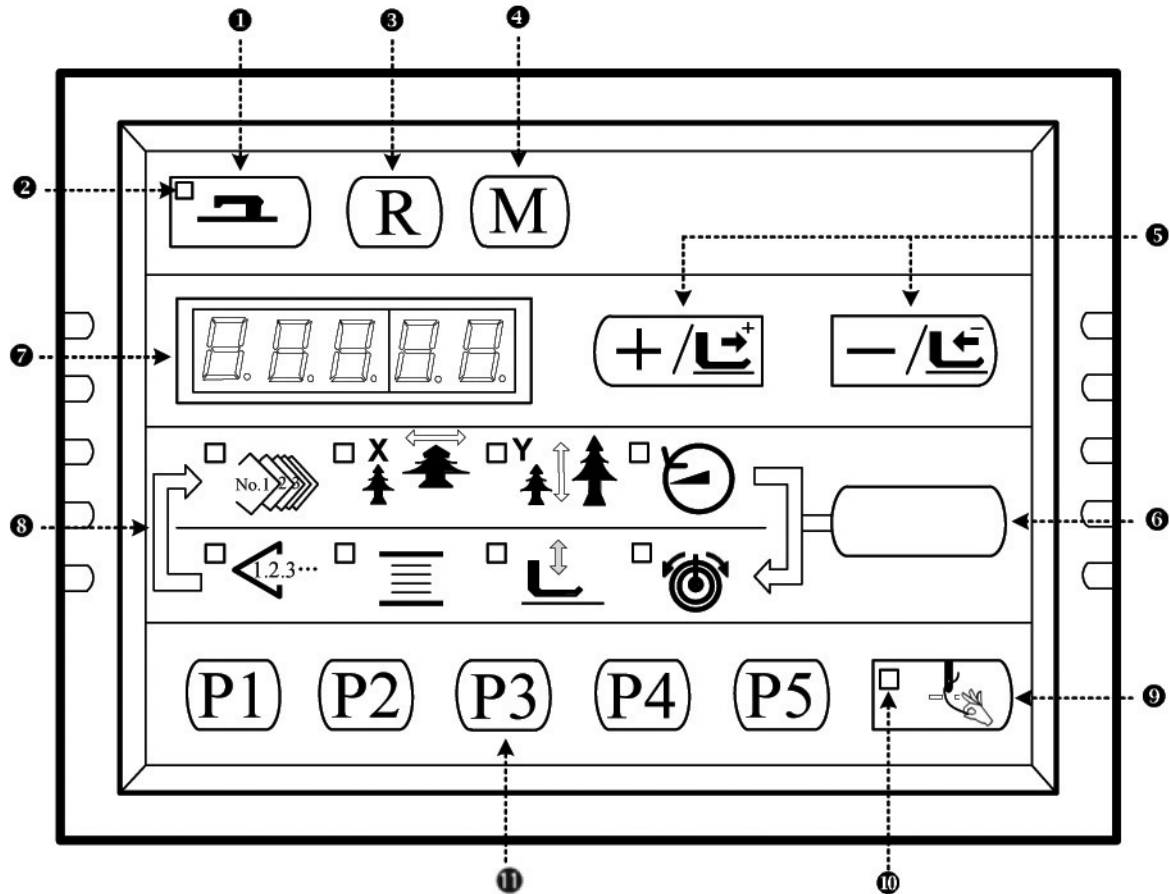

❶ “Ready” key

This key changes over the setting state from the panel to the sewing state where the sewing machine actually operates.

❷ “Sewing LED”

This LED goes off at the time of setting state and lights up at the time of sewing state. Change over can be performed with “Ready” key.

❸ “Reset” key

This key is used for canceling error or returning the set value to the initial value.

❹ “Mode” key

This key makes the setting mode of the memory switch.

❺ “+/Feed forward” key and “-/Feed backward” key

This key is used for changing pattern NO. and X/Y scale, and feed forward / feed backward.

❻ “Selection” key

This key selects the item to be set. Item selection LED of the selected item and the set value are displayed.

❼ Data indication LED

This LED indicates the set values of the selected items such as pattern NO., X/Y scale, etc.

⑧ Item selection LED

LEDs of the selected items light up.



Pattern NO.



X Scale



Y Scale



Max, Speed
Limitation

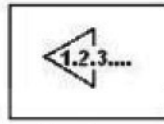

Sewing
Counter

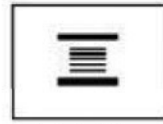

Bobbin
Winder

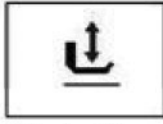

Work Clamp
Foot Lowering

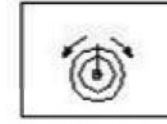

Thread
Tension

⑨ Needle thread clamp ON/OFF key

This key selects effective / ineffective of needle thread clamp. When it is effective, needle thread clamp display LED lights up.

⑩ Needle thread clamp display LED

When this LED lights up, needle thread clamp operates.

⑪ Needle thread clamp display LED

This key registers the pattern. When this key is pressed, the pattern registered here can sew immediately.

2.2 Installing the Main Motor

Assemble the main motor to the main shaft **①** through the coupling **②**. And you need 4 screws to fix the coupling to the main shaft and the main motor. Fix the coupling with No.1 Screw **⑥** and make sure that it is vertical towards the Flat Section, and then screw No.2 screw **③**. Fix the coupling to the main motor with No.3 screw **⑤**, and make sure it is vertical to the flat section of the main motor. Then screw the No.4 screw **④** to finish the assembling task. The following diagram shows you the details:

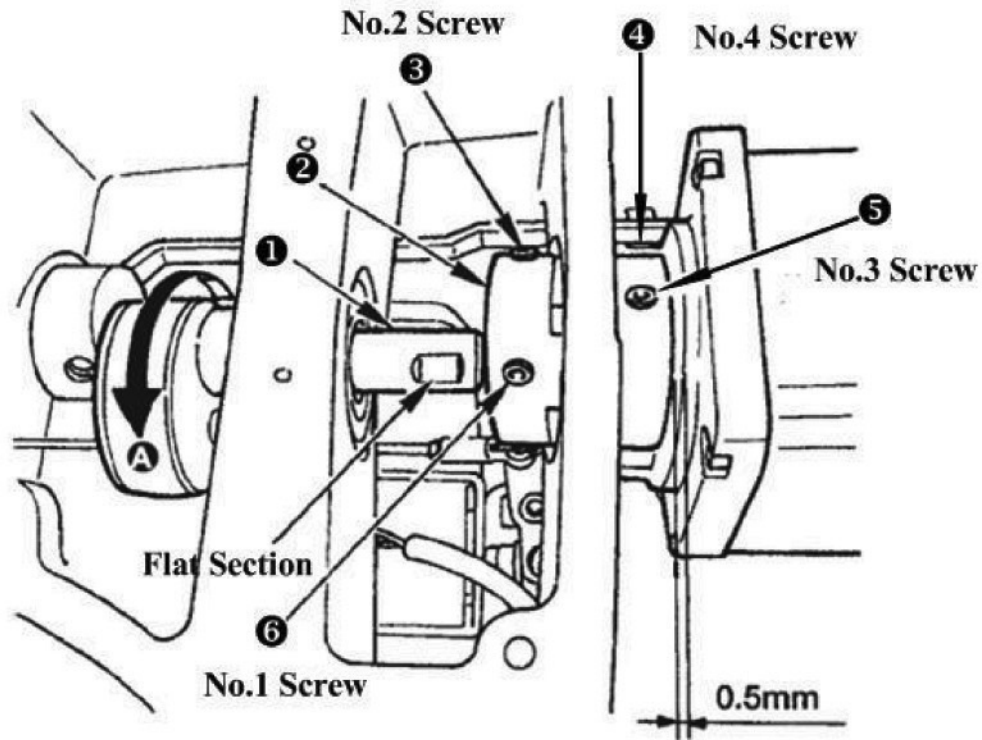

This following diagram shows you the position of the main motor (look from back, and the line is on your left-hand side):

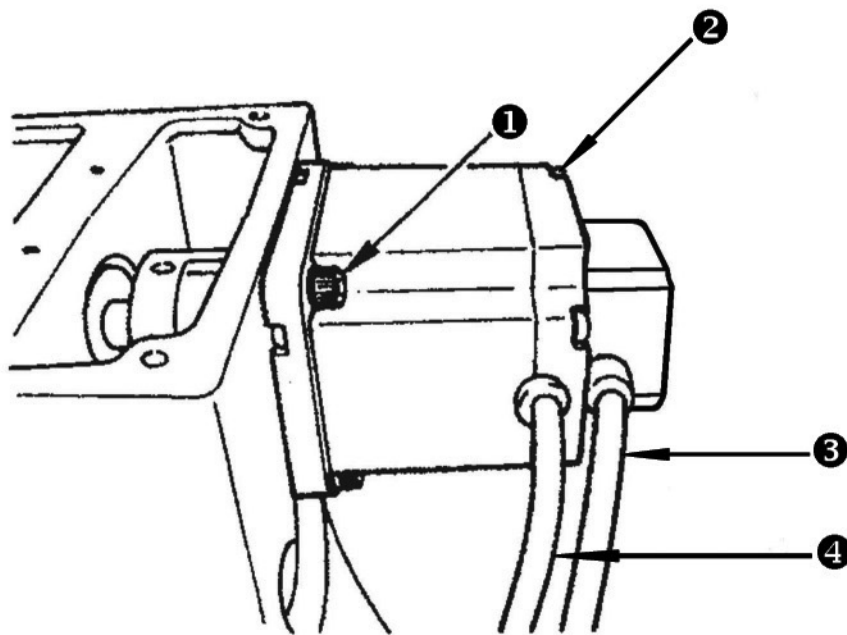





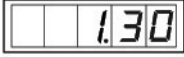

① Screws for fixing the main motor, totally 4; ② Screws for fixing the back of the motor, totally 4; ③ Sensor Cable; ④ Power cord.

2.3 Test Mode

This mode is set to facilitate the electrical check for maintenance work.

- 1) Press  key, while the Sewing LED is not illuminated, and then the Panel display

. Press    simultaneously, you would hear the ring of the buzzer, and then you are able to enter the test mode.

Note: If you failed to press    simultaneously, then you cannot enter the test mode.

- 2) Press  key to enter the test mode, and the screen displays “CP---”, as shown following:

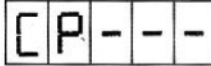

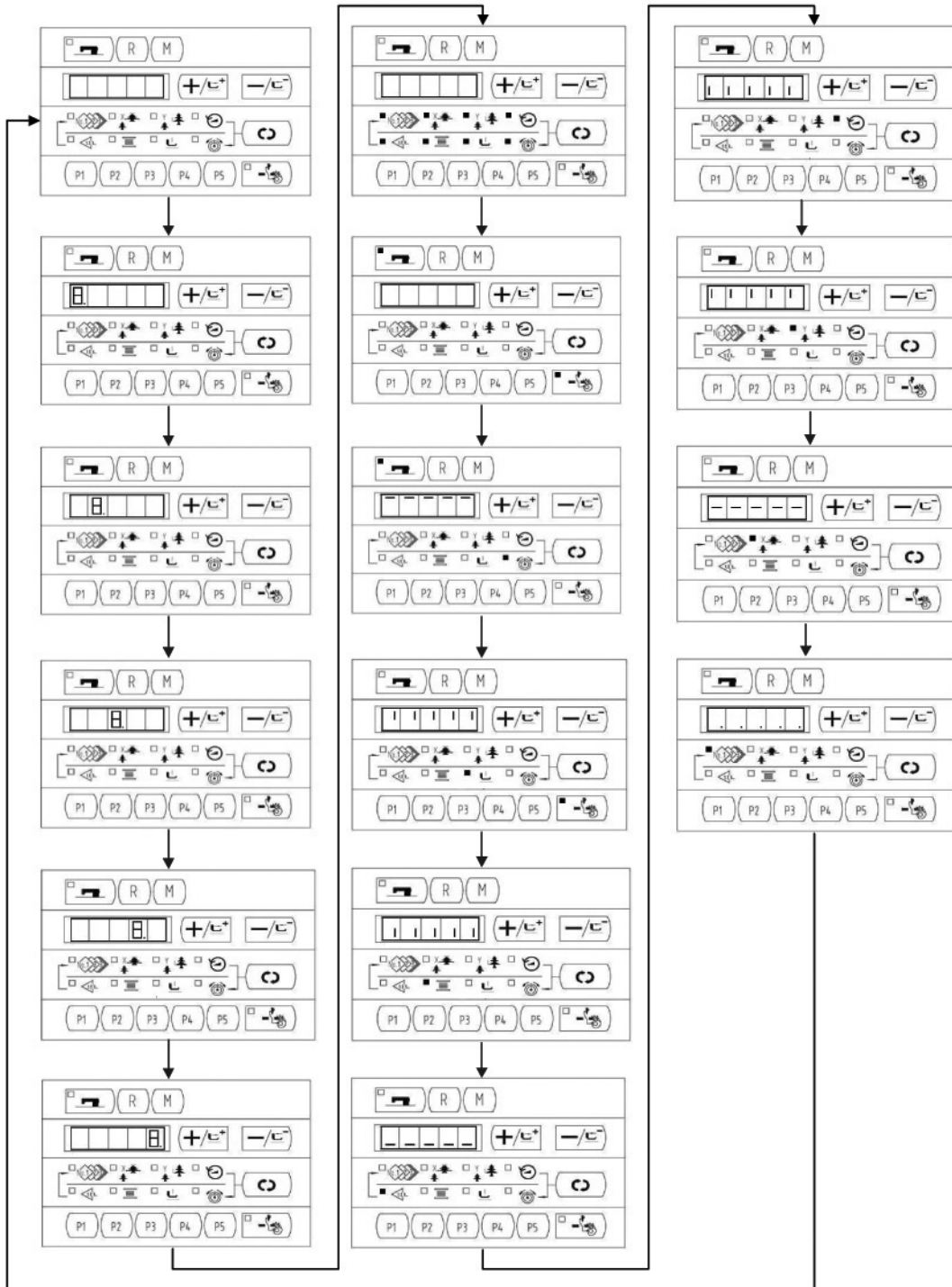

- 3) Press  key to start the Display Test. It automatically examine every 8-bit segment LED Display Module and the LED light illuminated or not, in a cycle process. The process is shown following:



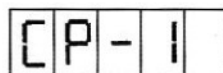

4) Press  key again to end the Display Mode and the screen displays “CP-1”, as shown following:

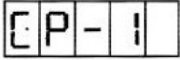
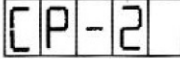
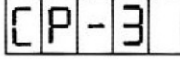
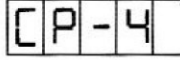
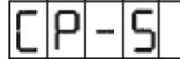
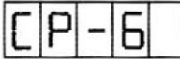
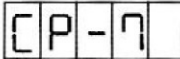
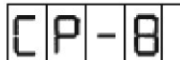

Note: You are not allowed to conduct other tests before the Display Mode Test.

5) Press 、 key to change the Indication NO. For details, please refer to the list below:

Indication No.	Item	Description
	Input signal check	State of the switch and the sensor will be indicated by 9 LEDs.
	X/Y motor and Original Retrieval check	To indicate the X/Y motor step motion and original adjustment.
	Continuous operation	Initial setting of the operation conditions will be performed, and the mode will move to the continuous aging mode.
	Number of revolutions of main shaft check	Output of the specified number of revolutions will be made and the actual number of revolutions will be indicated.
	_____	_____
	Presser and Trimming Original Retrieval check	Indicate the presser/trimming motor to move step by step; indicate original retrieval and the state of presser/trimming sensor.
	Thread Clamp and Original check	Indicate the thread clamp motor to move step by step; indicate original retrieval and the state of thread clamp/origin sensor.
	_____	_____

6) Press  key to check the items.

7) Press  to end up the test and return back to Step 5), however, if “CP-3” is selected, it is impossible to return to other test modes. Turn Off the power and turn On the power again in accordance with the starting way of the test mode.

2.3.1 CP-1 (Input Signal Check)

Status of input of switches and sensors is indicated on the 8 LEDs.

The table below is the list of LED indication, and you can understand to which LED each switch or each sensor is assigned. When “CP-1” is indicated on the screen, press  key to enter into the mode and then number “1” is indicated.

Indicated No.
Press P1 and P2 simultaneously and the No. will automatically add by 1

Indicate the status of item selection by LED ON/OFF. Refer to the table list.

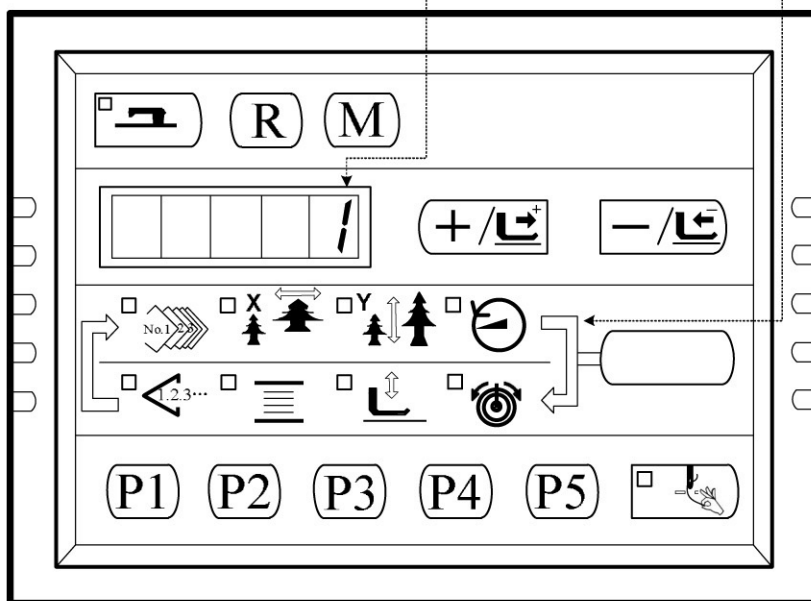



Indication of No.

Input No.	Pattern NO. LED	X Scale Rate LED	Y Scale Rate LED	Max. Speed LED	Sewing Counter LED	Bobbin Winder LED	Work Clamp foot lowering LED	Thread Tension LED
1	/	/						
2	/	/						
3	/	/	/	/	/	/	/	/
4	0 step of pedal	1 step of pedal	2 step of pedal	/	/	/	/	/
5	Presser solenoid sensor	Y origin sensor	X origin sensor	Thread Clamp origin sensor	Trimming sensor	Thread Clamp Sensor	/	/
6	Main shaft angle indication							
7	Z phrase of Main motor	/	/	/	/	/	/	/
8	/	/	/	/	/	Safety Switch	/	/

2.3.2 CP-2 (Origin Retrieval)

For origin adjustment, sensor adjustment of X/Y motor. The state of origin sensor and X/Y motor sensor will be indicated.

1) Prepare

Press  key to enter CP-2, "1" is displayed, and then press  to start origin retrieval. Meanwhile, the presser goes down, and the Sewing LED is illuminated. (The operation of pressing  is not necessary, you could skip it to continue Step2 operation)

2) Operation

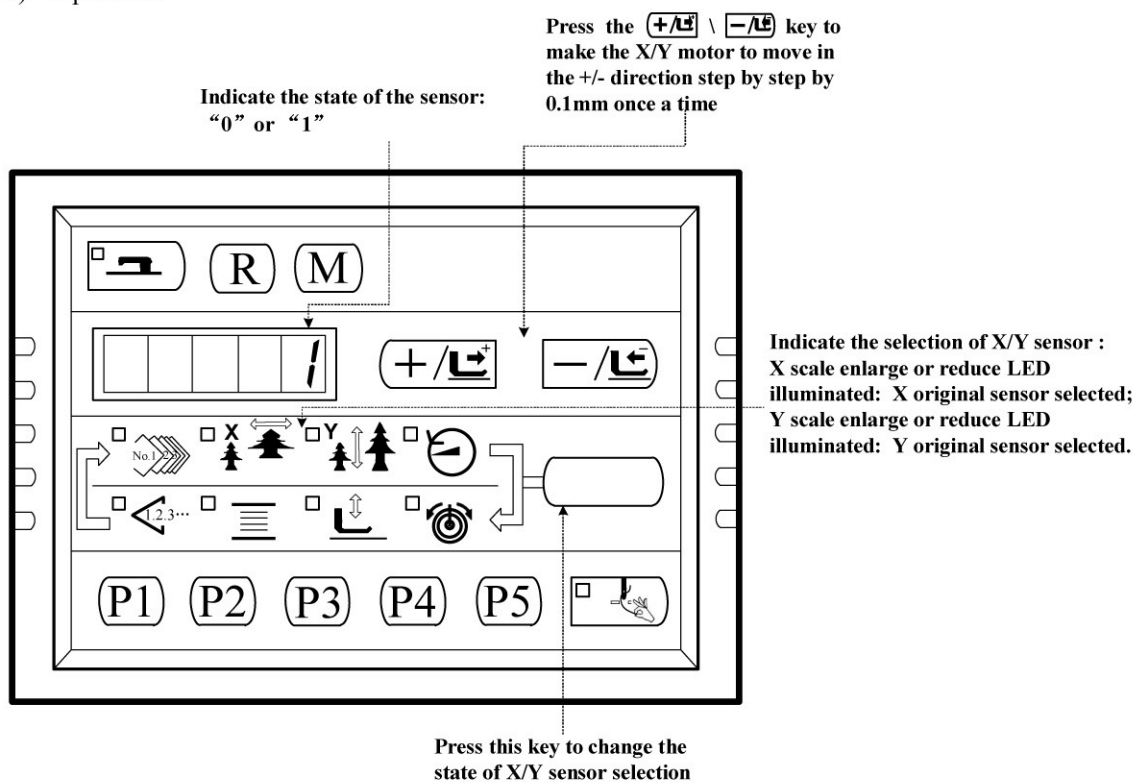

2.3.3 CP-3 (Continuous Operation)

When "CP-3" is indicated on the screen, press  key to enter the continuous operation mode. Perform the initial setting of the operation conditions, and move to the continuous operation mode.

1) Pause time setting



Press the  ,  key to set the time of pause.

Setting range: 1800 ms to 9999 ms (in a unit of 100 ms) (the default value is 2000ms)

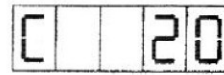
Update the time of pause by pressing down the  key, and the setting moves to the automatic origin retrieval setting.





2) Origin retrieval setting

Press the 、 key to set.

A0: Ineffective ;

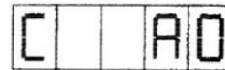
A1: Every time .



Press the  key to finish setting and move to Pattern No. setting.



3) Continuous Operation

In the Ordinary Sewing Mode, you can change the Pattern No., X./Y scale Enlarge/Reduce setting, the Max speed and so on. The continuous operation can be stopped at the time of pause by depressing the  key.

2.3.4 CP-4 (Revolution Movement)

Output of the specified number of revolution is made and the actual number of revolutions is indicated.

1) Prepare

Press  key to enter CP-4, and "S400" is displayed. Press the  key for origin retrieval and the Sewing LED lights up.

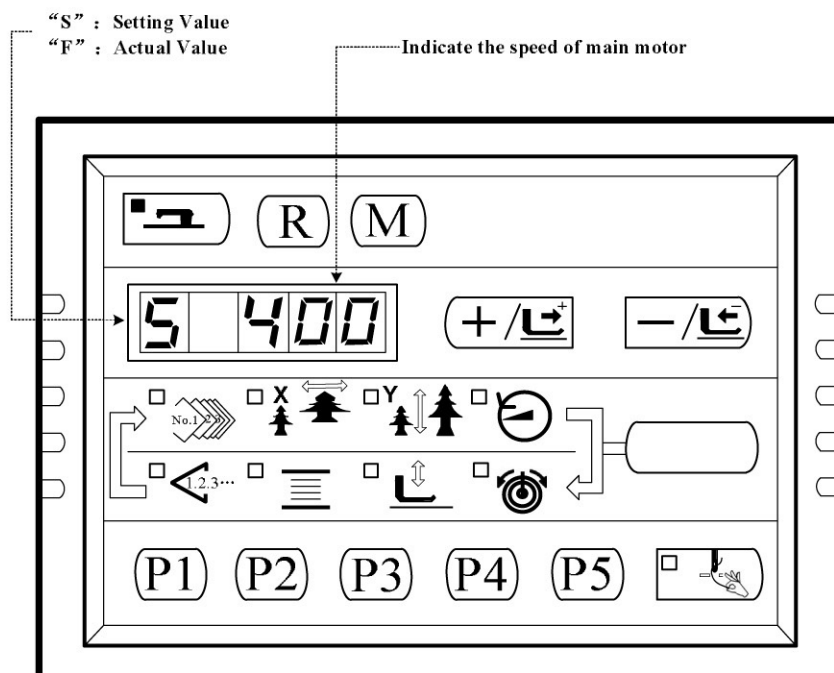

2) Operation

Press the  key to start the movement at the setting revolution; depress it again if you want to change the value of the revolution

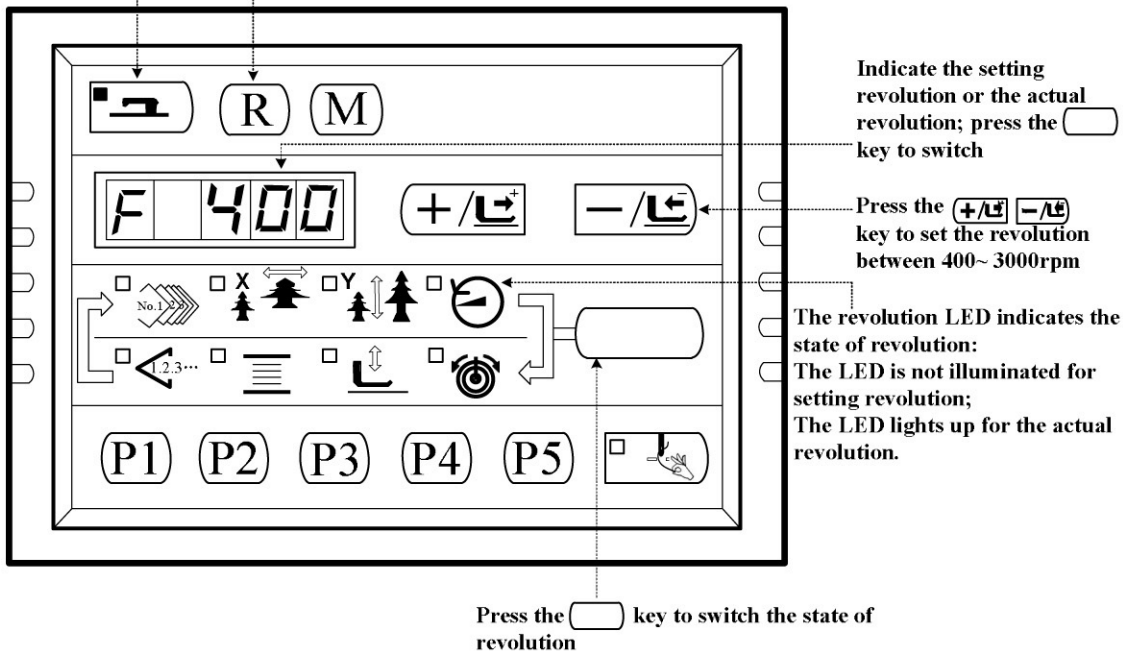

Press the  key to stop the movement.



2.3.5 CP-6 (Presser and Trimming Motor / Origin Sensor Check)

Indicate the presser and trimming motor to move step by step, origin retrieval and the state of origin sensor and thread trimming sensor.

1) Prepare

Press  key to enter CP-4, and then press  key for origin retrieval and the Sewing LED lights up.

2) Operation

Press  for 6 to 8 times, if the screen indication changes from "01" to "10", the trimming sensor works well; if not, please make proper adjustment.

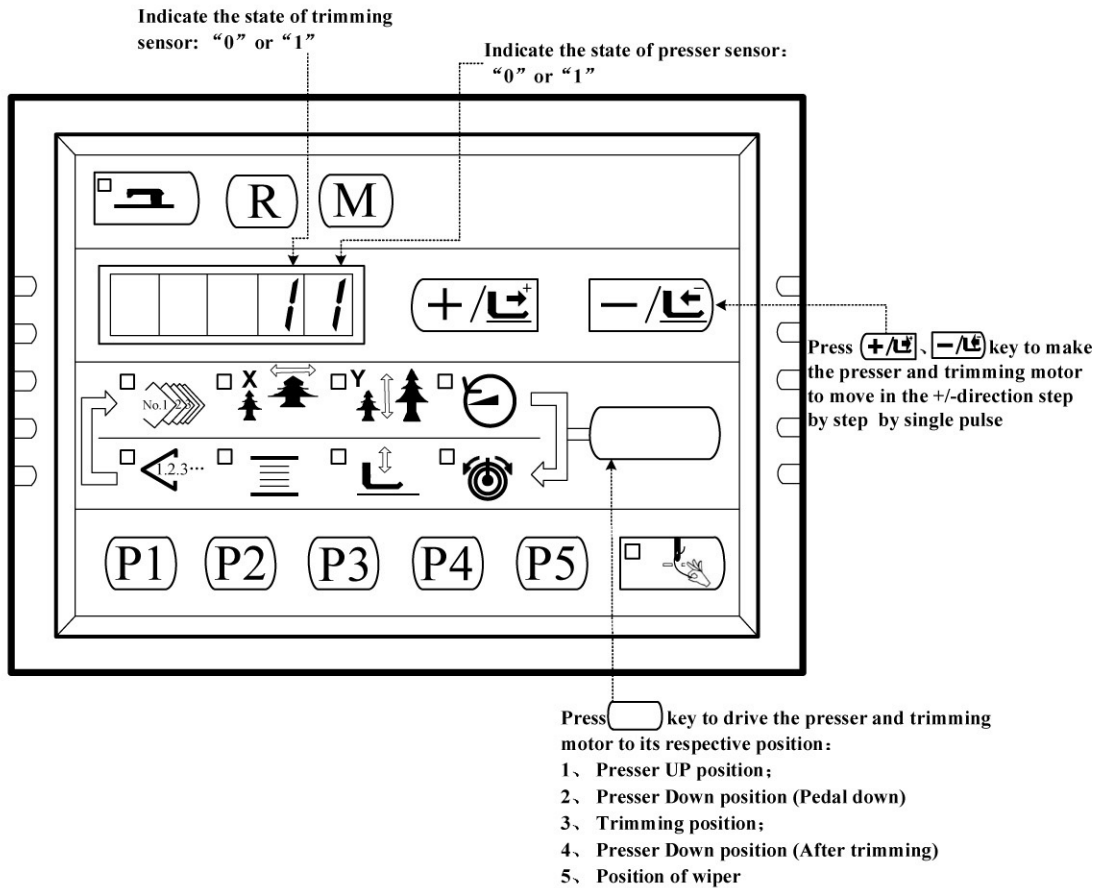

Press **[]** key to perform the functions above in a cycle. And press **M** key to exit this mode.

2.3.6 CP-7 (Thread Clamp Motor / Origin Sensor Check)

Indicate the thread clamp motor to move step by step, origin retrieval and the state of origin sensor and thread clamp sensor.

1) Prepare

Press **[]** key to enter CP-7, then press **[]** key for origin retrieval and the Sewing LED lights up. Press the pedal switch to perform the origin retrieval and "10" is indicated on the screen.

2) Operation

Press **+/⏪**, **-/⏩** key to make the thread clamp motor move step by step by single pulse.

Press **+/⏪** key to move the thread clamp backward; press **-/⏩** key to move the thread clamp forward.

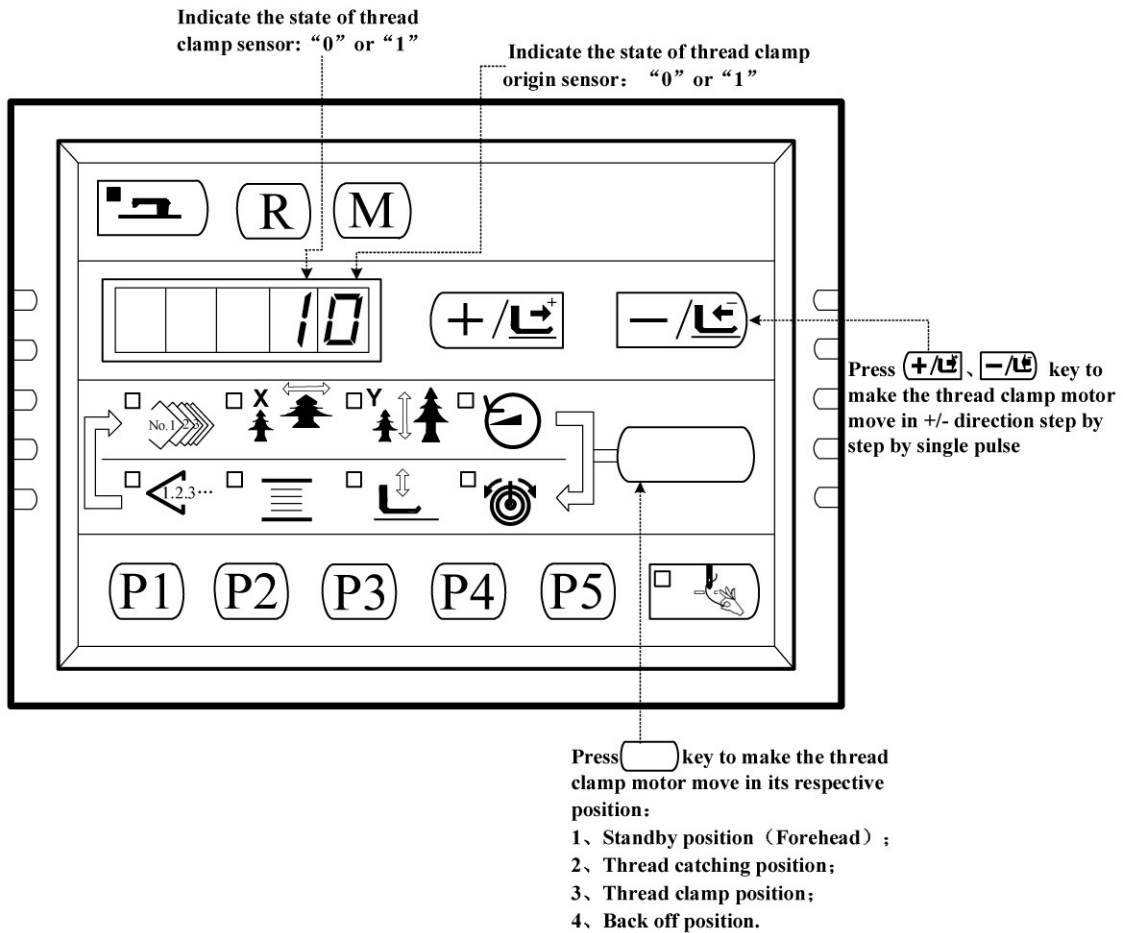

Press **()** key to perform the functions above in a cycle. And press **(M)** key to exit this mode.

2.4 Operation of the Sewing Machine (Basic)

2.4.1 Item Data Setting

Set each item following the procedure described below.

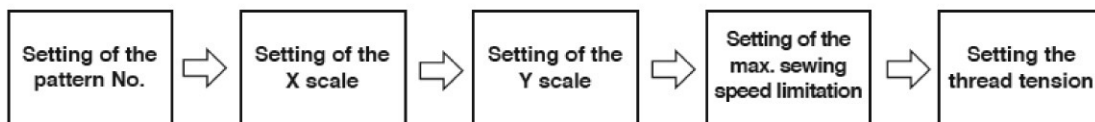

2. Turn ON the Power Switch
 Pattern No. of the item selection light up, and the pattern No. is indicated on the data display.
3. Setting of the Pattern No.

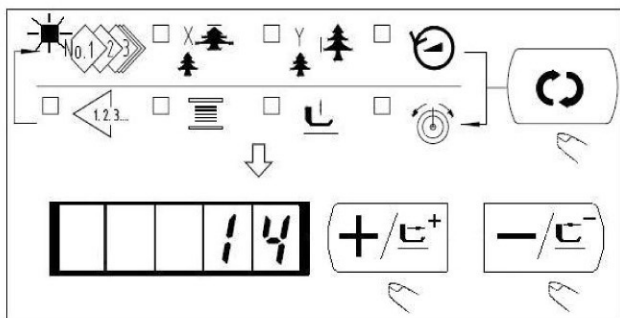

4. Setting of the X Scale

- (1) Press the key to indicate the item “Pattern No.” .
 - (2) Press the or key to indicate “14” on the display. (Pattern No. is set to 14.)
- Caution: Refer the pattern No. to the separate table**

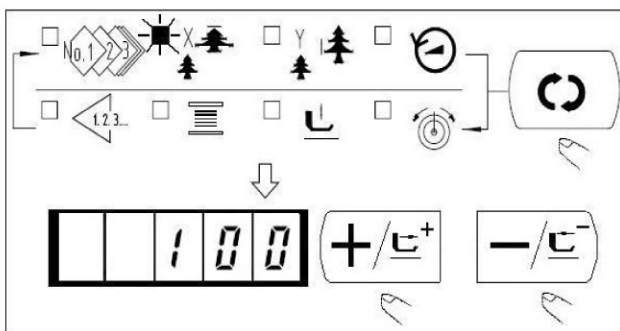

5. Setting of the Y Scale

- (1) Press the key to indicate the item “X scale” .
 - (2) Press the or to indicate “100”. (Set X scale to 100%)
- Caution:**
The setting exceeding 100% is dangerous since the needle and the cloth presser interferes with each other and needle breakage or the like will occur.

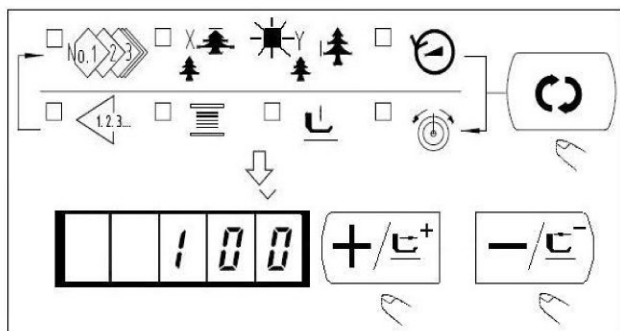

6. Setting of the Max. Sewing Speed Limitation



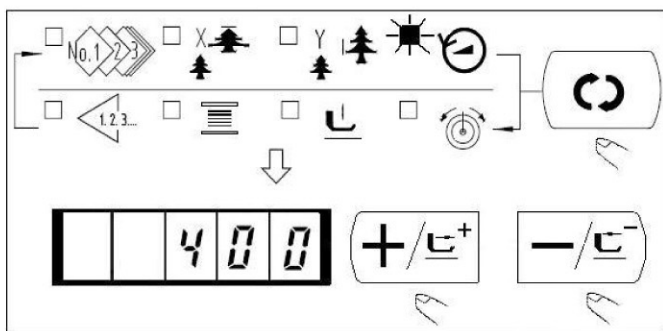

- (1) Press the key to indicate the item “Y Scale” .
 - (2) Press the or key to indicate “100”. (Set X scale to 100%).
- Caution:**
The setting exceeding 100% is dangerous since the needle and the cloth presser interferes with each other and needle breakage or the like will occur.

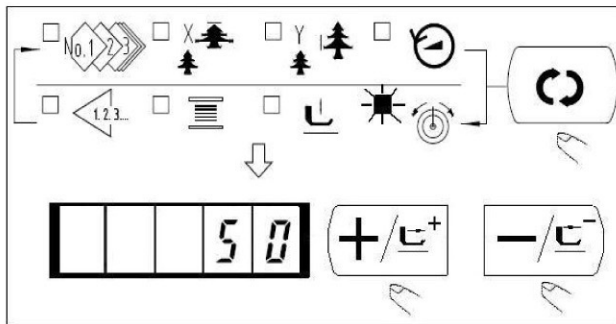

- (1) Press the key to indicate the item “Speed” .
- (2) Press the or key to indicate “400” (Setting of 400rpm)
- (3) Press R key to set the system default value, the Max. speed.

7. Setting the Thread Tension



- (1) Press the  key to indicate the “Thread Tension” .
- (2) Press the  or  key to indicate “50” (0 to 200 can be set.)



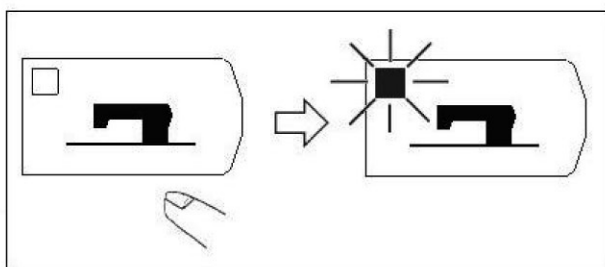

8. Finish of Setting



- (1) Press the  key.
- (2) After the work clamp feet have moved and gone up, the sewing LED lights up, and the sewing is ready.

Caution:

When the presser is raised, be careful that fingers are not caught in the presser since the presser moves after having lowered.

- ★ When  key is pressed, the set value of pattern No., X/Y scale, etc, are memorized.
- ★ If  key is pressed, you can make sure of the respective setting items again. However, the items can not be changed in the state that the Sewing LED is lit up.
- ★ When  key is pressed, the Ready LED goes off. Set values of the respective items can be changed.
- ★ Use the machine after confirming the pattern No. When  key is pressed while the pattern No. is indicated "0"(state at the time of delivery), error display E-10 appears. At this time, re-set the Pattern No.
- ★ When turning OFF the power without pressing  key, the set values of pattern NO., X/Y scale, number of max. rotation, and thread tension are not memorized.

2.4.2 Checking the Contour of a Sewing Pattern

Warning:

Make sure without fail of the contour of the sewing pattern after selection of the sewing pattern. If the sewing pattern extends outside the work clamp feet, the needle will interfere with the work clamp feet during sewing, causing dangerous troubles including needle

breakage.

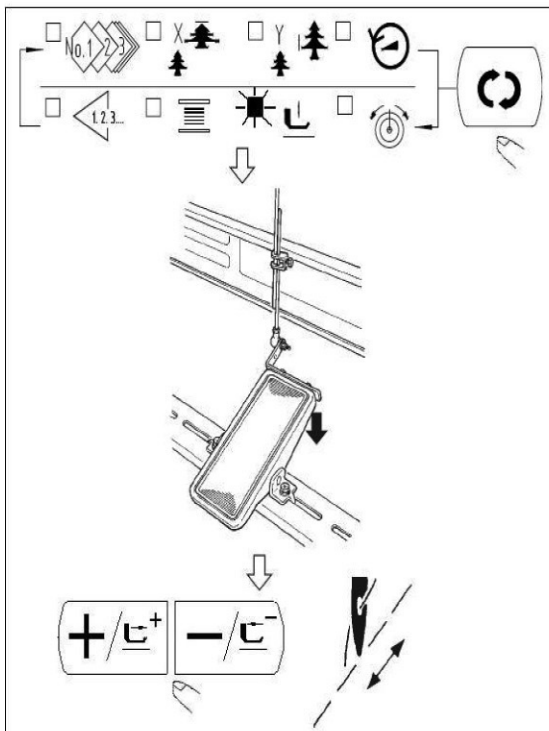

(1) Press the key to make the Ready LED light up.

(2) Select the work clamp foot lowering with key. Lower the work clamp foot with the foot switch.

Note: The sewing machine does not start even when the foot switch is depressed under this mode.

(3) Press key in the state that the work clamp foot is lowered.

Note: The work clamp foot does not go up even when the foot switch is detached.

(4) Confirm the contour of the pattern with

or key.

(5) The work clamp foot will go up when is pressed.

(6) Use key to move to other items, then press key to finish, and the sewing LED goes off.



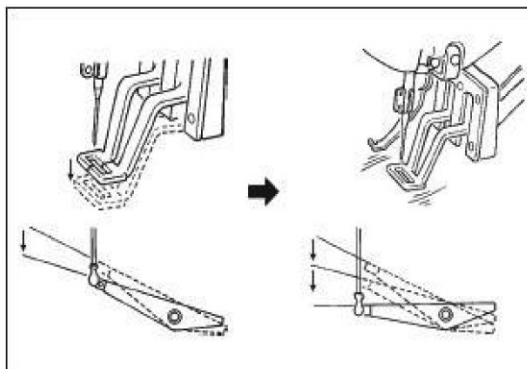



2.4.3 Sewing

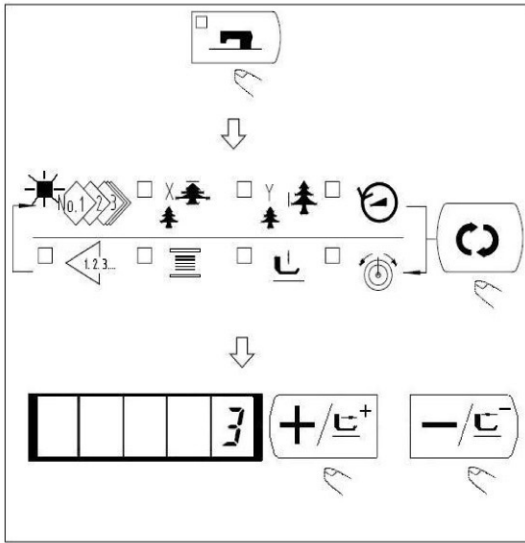

- (1) Set a workpiece on the work clamp foot section.
- (2) Depress the pedal switch to the first step, and the work clamp feet will come down. If you detach your foot from the pedal switch, the work clamp feet will go up.
- (3) Depress the pedal switch to the second step after descending the work clamp feet at the first step, and the sewing machine will start sewing.
- (4) After the sewing machine completes sewing, the work clamp feet will go up, and return to the sewing start position.







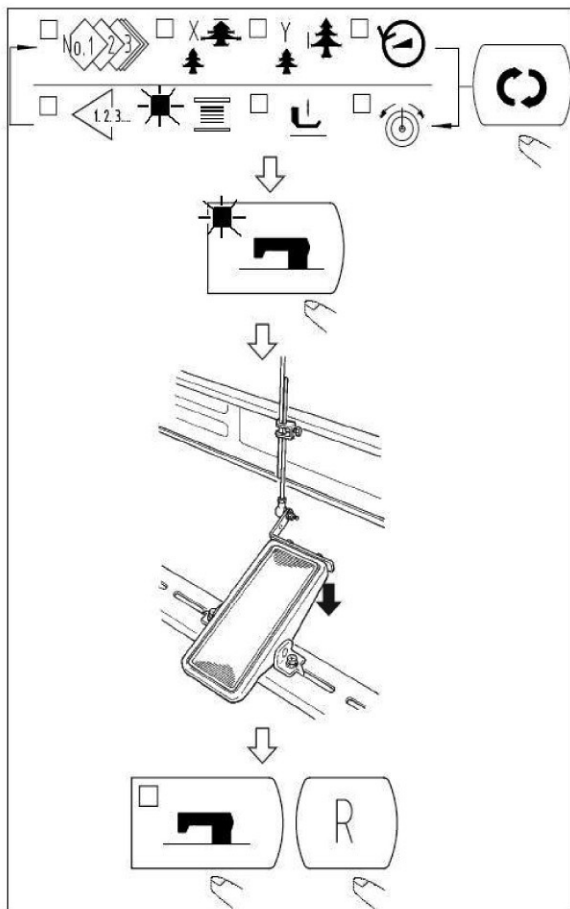

2.4.4 Change to Other Sewing Pattern



- (1) Make sure the Sewing LED go off with  key.
- (2) Press  key and select the item of pattern No. .
- (3) Set the pattern No. with  key or  key.
- (4) Similarly, setting of X/Y scale, speed, etc. is performed.
- (5) When  key is pressed, the Sewing LED light up and the sewing machine is in the sewing ready state.

2.4.5 Winding a Bobbin



- (1) Press  key to make the Sewing LED go off.
- (2) Select the bobbin winder  with  key.
- (3) Press  key. The work clamp feet come down and the Sewing LED lights up.
- (4) When the pedal is depressed, the sewing machine rotates.
- (5) When the pedal is depressed again, or  key or  key is pressed, the sewing machine stops.
- (6) When  key is pressed, the Sewing LED goes off, the work clamp feet go up and  key become effective.

Caution: Bobbin winder does not work immediately after Turning ON the power. Perform the bobbin winding after setting pattern NO. or the like once, pressing the  key, and making the Sewing LED light up.

2.4.6 Thread Clamp Device

Trouble of sewing (slip-off of needle thread, stitch skipping, or stain of needle thread) at the time of high speed start can be prevented with the thread clamp device. The thread clamp device works in the state that the thread clamp indication LED lights up and does not work when the LED goes off.

Changeover of ON/OFF motion is performed with  key. When the thread clamp device is OFF, the start automatically becomes the slow start.

Caution: When memory switch No.35 is “1”(prohibited), the thread clamp does not work.

In addition,  key is ineffective.

*Masters that demand special attention when using the needle thread clamp device

- (1) In case of with the needle thread clamp (motion), make shorter the length of needle thread remaining on the needle at the sewing start for use. When the length of needle thread is lengthened, needle thread on the wrong side of material is apt to protrude. In addition, when the length is excessively lengthened, the end of needle thread held by the needle thread clamp may be rolled in the seams.

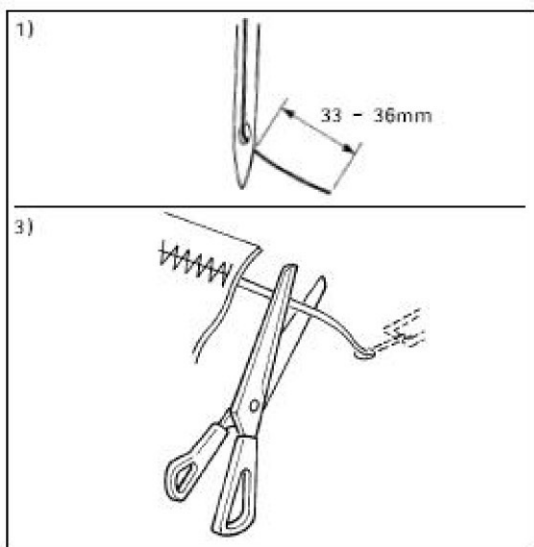

1. In case of with the needle thread clamp, the standard of the length is 33 – 36mm.
2. When needle threadlong after replacing thread or the like or sewing while holding needle thread by hand, Turn OFF the THREAD CLAMP  key.
3. When the needle thread held with the thread clamp is rolled in the seams, do not draw the material forcibly and cut the connecting needle thread with the scissors or the like. The seams are not damaged since it is the needle thread at the sewing start.

- (2) It is possible to adjust needle thread shorter by making the needle thread clamp work while holding the stabilized sewing at the start of sewing and the gathering (bird's nest) of needle thread on the wrong side of material can be lessened. However, for the pattern which the stitch for neatly rolling in needle thread is short, needle thread may protrude from the wrong side of material. Select with/without thread clamp referring to the item below.

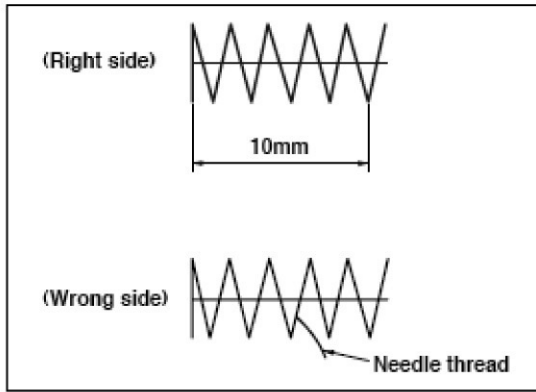

1. When the sewing length is short (less than approximately 10mm), the end of needle thread may protrude like beard even adjusting needle thread shorter.

- (3) When the type of lower plate ❶ that material does not come in closely contact with throat plate ❷ is used, needle thread on the wrong side of material may be rolled in the seams regardless of needle thread play or sewing length.

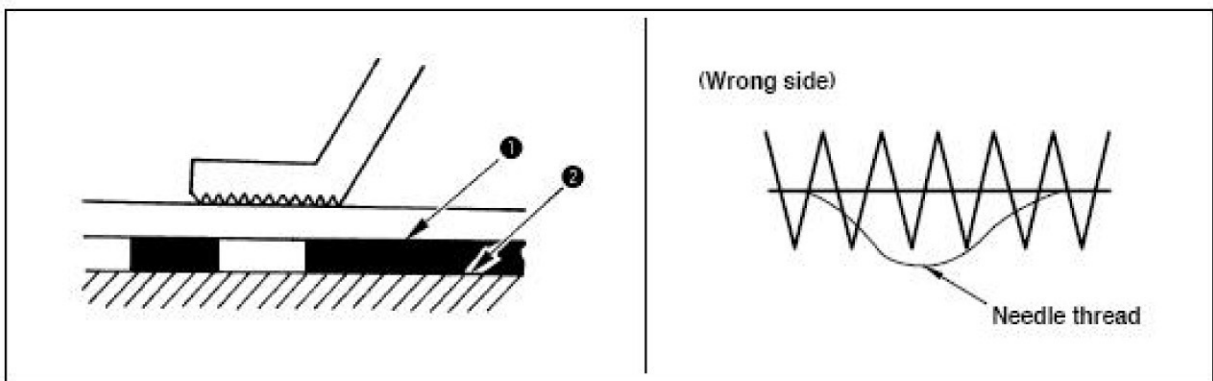

- (4) When the thread clamp is used, and bobbin thread at the sewing start appears on the right side of material, reduce thread tension at the sewing start (2 to 3 stitches) and bobbin thread becomes less conspicuous.

[Example of setting] Tension of 1 to 2 stitches at the sewing start is “20” when sewing tension setting is “35”.

2.4.7 Bobbin Thread Counter

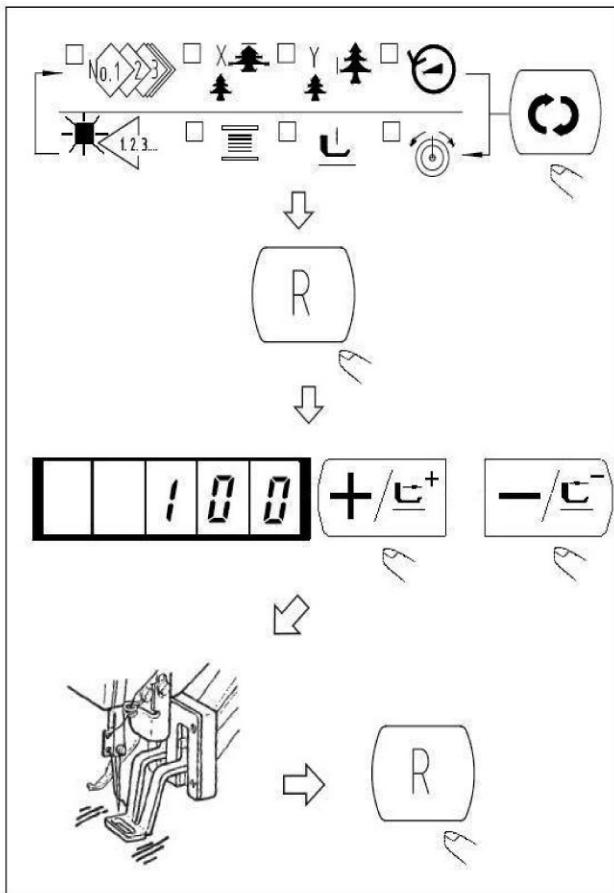

- (1) Press **⏪** key to indicate the Counter

- (2) Then press the **R** key.
- (3) Then press the **+/ε+** or **-/ε-** key, and set the specified number of times that can be sewn with a bobbin.
- (4) Every time, the sewing machine finishes a sewing cycle, counting-down is made by one.
- (5) When the sewing machine finishes the specified number of times, the sewing machine does not start even if depressing the pedal.
- (6) Replace the bobbin with a new one, and press the **R** key. The value of the counter returns to the set value.
- (7) Repeat the steps of procedure from the steps (3) to (5).

2.4.8 Temporary Stop

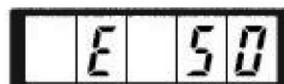
When memory switch No.31 is set to “1”, **R** key can be used as the temporary stop key.



- (1) Sewing machine stops by means of **R** key.
 Error 50 is indicated.
- (2) There are two operations after stop as below.
 - ❶ Press **R** key to perform thread trimming, perform position with **+/ε+** or **-/ε-** key, and re-start by means of the start switch.
 - ❷ Press **R** key to perform thread trimming, and press again **R** key to return to the origin.

2.4.9 Setting the Pattern Thread Tension



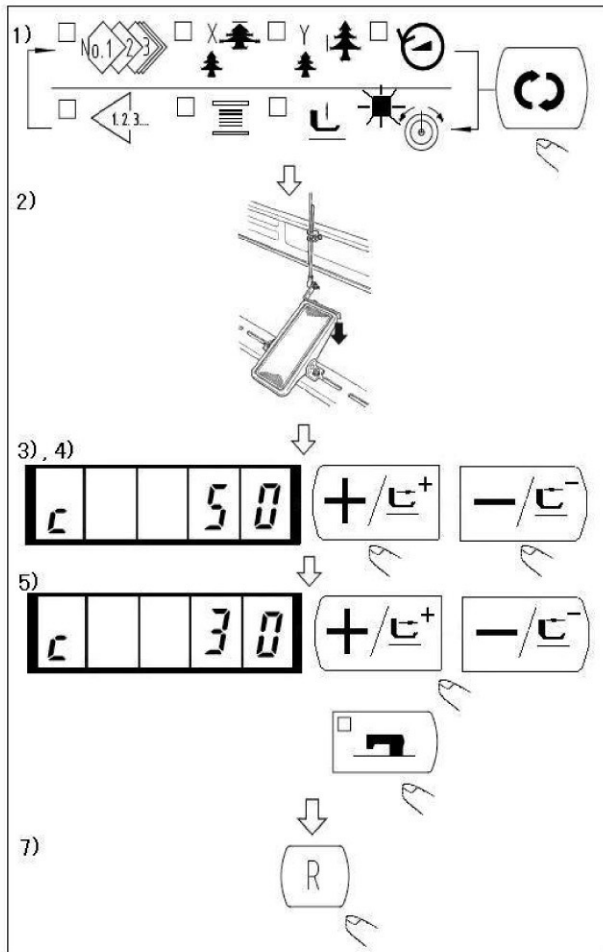







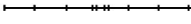
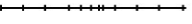
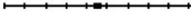

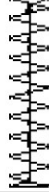







Needle thread tension for 6 stitches at the sewing start, the portion which is changed over from basting stitch to zigzag stitch, and the portion of the stitch at the sewing end can be individually set.

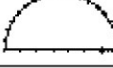



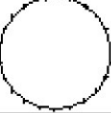
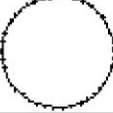









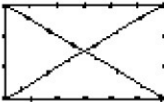
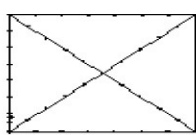

- 1) When the sewing LED lights up, press key to indicate the needle thread tension .
- 2) Lower the presser with foot pedal. **(Caution: When the foot pedal is depressed until it will go no further, the sewing machine starts. So, be careful.)**
- 3) Move the feed with or key.
- 4) “c” is indicated at the position where the tension position is possible.
- 5) Pressing key, set the tension with or key.
- 6) Repeat steps 3), 4) and 5) to set the tension.
- 7) When setting is complete, press key. The presser moves to the origin and goes up.

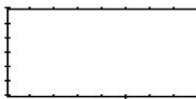
2.4.10 Table of the Standard Patterns

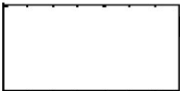
NO.	Stitch Diagram	Numbers of Stitches	L×W (mm)	NO.	Stitch Diagram	Numbers of Stitches	L×W (mm)
1		42	16×2	2		42	10×2
3		42	16×2.5	4		42	24×3
5		28	10×2	6		28	16×2.5
7		36	10×2	8		36	16×2.5
9		56	24×3	10		64	24×3
11		21	6×2.5	12		28	6×2.5
13		36	6×2.5	14		15	8×2
15		21	8×2.2	16		28	8×2
17		21	10×1	18		28	10×1

19		28	25×1	20		36	25×1
21		41	25×1	22		44	35×1
23		28	4×20	24		36	4×20
25		42	4×20	26		56	4×20
27		18	1×20	28		21	1×10
29		21	1×20	30		28	1×20
31		52	10×7	32		63	12×7
33		24	10×6	34		31	12×6
35		48	7×10	36		48	7×10
37		90	24×3	38		28	8×2
39		28	12×12	40		48	12×12
41		29	2.5×20	42		39	2.5×25
43		45	2.5×25	44		58	2.5×4.4





45		76	2.5×4.4	46		42	2.5×4.4
47		91	8×8	48		99	8×8
49		148	8×8	50		164	8×8
51		49	17×10	52		67	20×20
53		21	8×8	54		32	26×15
55		41	25×25	56		39	19×15
57		47	24×15	58		63	32×20
59		124	10×10	60		85	10×12

2.5 Operations of P Pattern and C Pattern

2.5.1 Perform Sewing Using the Pattern Key ()

Patterns (No.1 to 200) which have been already registered can be registered to P1 to P50. It is possible to change and register the scale, max speed limitation, thread tension and sewing position. Same as the patterns (No.1 to 200), P1 to P50 are used by the selection by scrolling the pattern Nos. The pattern calling from P1 to P25 can be made by one-touch as well.

When selecting P6 to P25, perform the selection by combination (simultaneously pressing) of

     keys as shown in the table below.

P-No.	Selection Key	P-No.	Selection Key	P-N	Selection Key	P-No.	Selection Key
-------	---------------	-------	---------------	-----	---------------	-------	---------------

				o.			
P1	P1	P8	P1+P4	P15	P4 +P5	P22	P2+P3+P4
P2	P2	P9	P1+P5	P16	P1+P2+P3	P23	P2+P3+P5
P3	P3	P10	P2+P3	P17	P1+P2+P4	P24	P2+P4+P5
P4	P4	P11	P2+P4	P18	P1+P2+P5	P25	P3+P4+P5
P5	P5	P12	P2+P5	P19	P1+P3+P4		
P6	P1+P2	P13	P3+P4	P20	P1+P3+P5		
P7	P1+P3	P14	P3+P5	P21	P1+P4+P5		

1. Register of the Pattern Key

Setting example: Register following setting to the P2, Pattern No.3, X scale rate: 50%, Y scale rate: 80%, Max. speed limitation: 2000 rpm, Pattern position: 0.5 mm to the right and 1 mm to the front.

- 1) Turn ON the power switch and press **(M)** key to enter mode setting (memory switch setting).
(Sewing LED should be put out.)

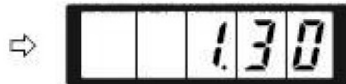

- 2) Indicate the pattern register mode

with **(+/-⁺)** or **(-/-⁻)** key.

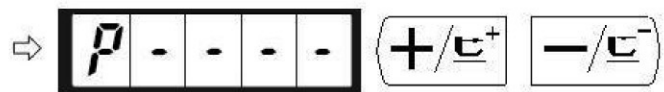

- 3) Press **()** key.

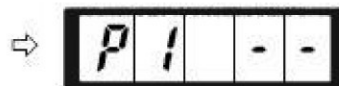

Enter the pattern register mode.

- 4) Press **(P2)** key. (Select P-No. to be registered.)

Selection can be performed with **(+/-⁺)** or **(-/-⁻)** key.

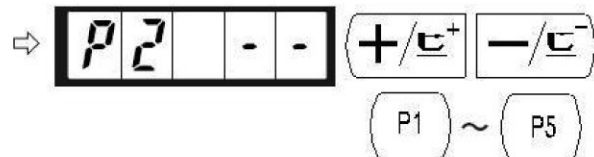

- 5) Press **()** key to indicate the Pattern No. .

Set the Pattern No. to “3” with **(+/-⁺)** or **(-/-⁻)** key.



6) Press and set as follows with or key.

X Scale rate : 50%,



Y Scale rate : 80%,



Max speed limitation :
"2000" rpm



Thread Tension "50"



7) Press key and "X Scale rate " indication becomes 0.0.

Traveling amount in X direction can be



set in 0.1mm unit. Set 0.5 with or key.



8) Press key and "Y Scale rate "

indication becomes 0.0.

Traveling amount in Y direction can be

set in 0.1mm unit. Set -1.0 with  or  key.



9) Press  key to finalize the setting.

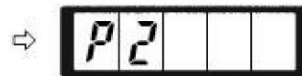

10) Press  key.

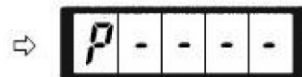

Pattern register mode is finalized.

11) Press  key.

Mode setting is finalized and the mode returns to the normal mode.

2. Sewing

Operation Example: After perform sewing of the contents of the register P2, perform sewing with the contents of P3.

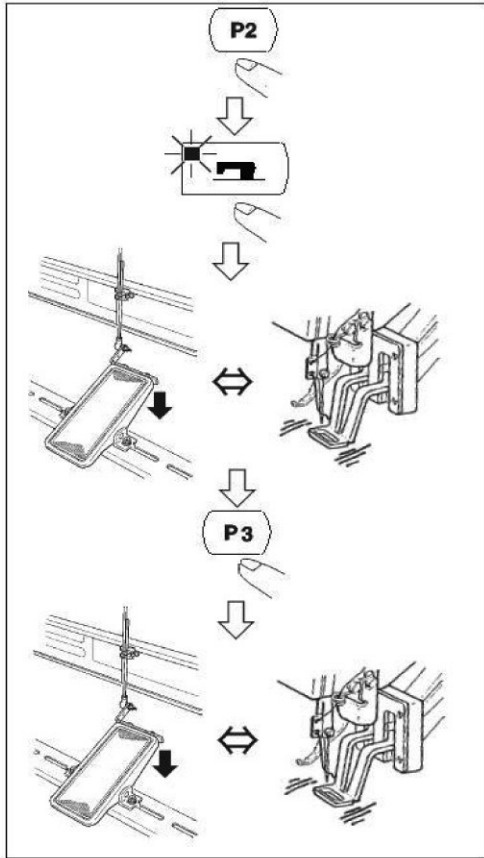

- (1) Turn ON the power switch.
- (2) Press the **P2** key.
- (3) Press the  key, and when the sewing LED lights up, the work clamp foot goes up after it has moved.
- (4) Check the contour of the sewing pattern.
(Refer to the item “Checking the Contour of a Sewing Pattern”).
- (5) If the contour of the sewing pattern is acceptable, the sewing can be made.
- (6) Press **P3** key after completion of sewing and the presser comes down. The presser moves to the sewing start point after origin retrieval and goes up.
- (7) Perform the above item (4) and (5).

2.5.2 Perform Sewing Using the Combination Function

By arranging in order to use the pattern register (P1 to P50) which have been already registered and registering in C1 to C20, the sewing pattern will change in the order every time the sewing machine finishes the sewing. Every one combination No. can be registered up to the maximum 30 patterns.

i. Register of the Combination

Setting example: Combine in the order of P1, P2 and P3, and register them in the C1.

- 1) Turn ON the power switch and press **M** key to enter the mode setting (memory switch setting).
(Sewing LED should be put out.)

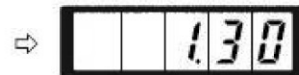

- 2) Indicate the combination mode with **+ / C+** or **- / C-** key.



- 3) Press  key. Sewing LED lights up to enter the

combination mode. C1 to C20 can be selected with



4) Press key, and then press key.

is set to the first pattern of C1. P1 to P50 can be selected with or key as well.

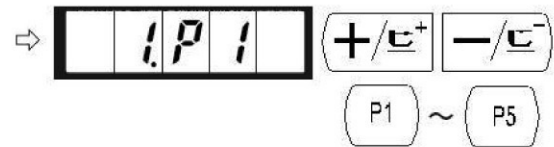

5) Press key, and then press key.

P2 is set to the second pattern of C1. P1 to P50 can be selected with or key as well.

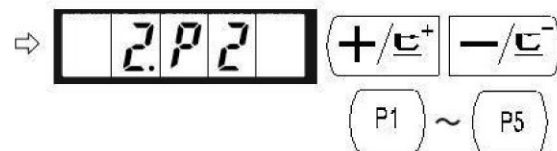

6) Press key, and then press key.

P3 is set to the third pattern of C1. P1 to P50 can be selected with or key as well.

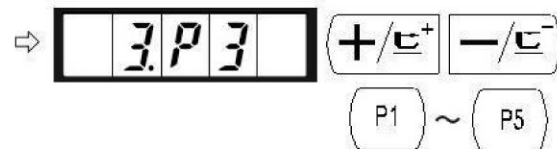

7) Press key to finalize the register.

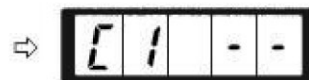

8) Press key. Combination register mode is finalized.



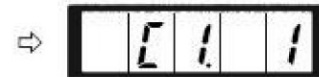

9) Press  key.

Mode setting is finalized and the mode returns to the normal mode.



ii. Sewing Operation

Operation example: Perform sewing with the contents of the registered C1.

- (1) Turn ON the power switch.
 - (2) Set the pattern No. to “C1” using the  or  key.
 - (3) Press the  key. When the sewing LED lights up, the work clamp feet will go up after having moved.
 - (4) If the contour of the pattern is acceptable, the sewing can be made.
 - (5) Every time the sewing is finished, the step is made in the order of the combination. After completing one cycle of sewing., the step returns to the first step.
- ✧ When you desire to return the pattern to the previous one or skip the next pattern after sewing, press  or  key in a state that the sewing LED lights up.
 - ✧ If the contents of P1 to P50 are changed after registration of C1 to C20, the contents of P1 to P50 used in C1 to C20 will change. So, be careful.
 - ✧ Make sure of the contour of the pattern for each or the patterns. (Refer to the item “Checking the contour of the sewing pattern”.)

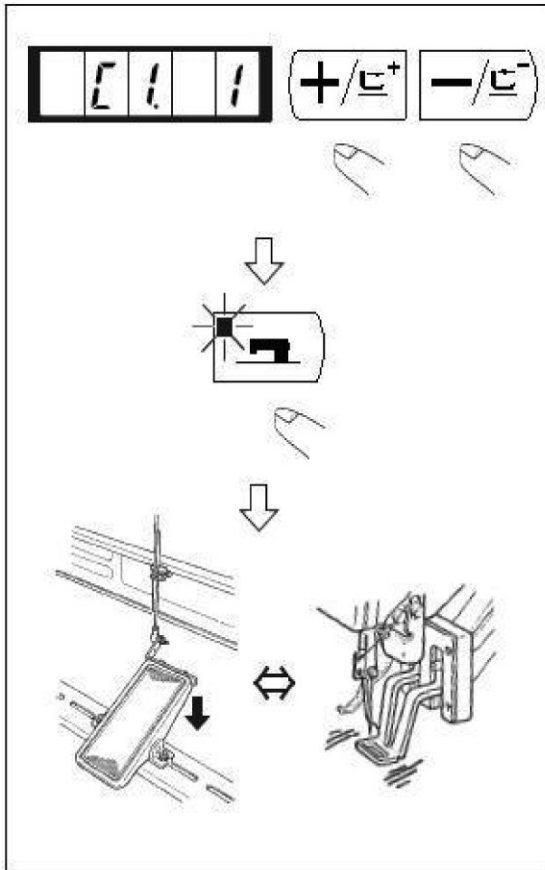

2.6 How to Use the Memory Switch (User Class)

The sewing machine operation can be changed by changing the setting of the memory switch.

2.6.1 Start and Change of the Memory Switch

- 1) When **M** key is pressed in the state that the sewing LED is put out, the memory switch setting mode is obtained.

1.30 which is indicated when “M” key is pressed indicates that the max. speed limitation of the first memory switch is 3,000 rpm. (State at the time of delivery from factory)

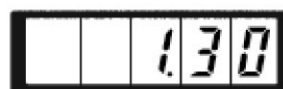

Three figures from the top are memory switch Nos.

Two figures from the bottom are contents of setting.

- 2) Change the memory switch No. with

+ / - or **- / +** key.





3) Adjust the memory switch No. to the No.

you desire to change, and press  key,
the sewing LED lights up.

4) Change the content of the memory switch

with  or  key.   

5) The value can be returned to the value at the time of delivery from the factory with  key.

6) Press  key to register the contents of change. Sewing LED goes off and the mode returns to the selective state of the memory switch No.

7) Press  key to finalize the memory switch setting mode and the mode returns to the normal mode.

2.6.2 Example of the Memory Switch Setting

1. Setting the Max. speed Limitation



Setting example: Setting the max. speed limitation to 1,800 rpm.

1) Press  key in the state that the sewing LED is put out.

The memory switch is started and the contents of memory switch No.1 are indicated.



It is not necessary to change the sewing speed since the max. speed limitation of the sewing machine is set with memory switch No.1. The indicated memory switch No. can be changed

over with  or  key.

2) Press  key in the state that memory switch

NO.1 is indicated to make the sewing LED light up. The contents of memory switch No.1 (max. speed limitation value of the sewing machine) are indicated.



3) Set “1800” with  or  key.

4) Register the value with  key. Sewing LED goes off.

5) Press  key to return to the normal state.

2. Setting the Soft Start Speed at the Sewing Start

The speed of the first stitch to the fifth stitch at the sewing start can be set in a unit of 100 rpm. Two kinds of settings, in case of with needle thread clamp and without needle thread clamp can be performed. (See Table of Functions of the Memory Switch.)

In case of needle thread clamp unit: rpm



	State when delivered (rpm)	Setting range
1 st Stitch	1500	400~1500
2 nd Stitch	3000	400~3000
3 rd Stitch	3000	400~3000
4 th Stitch	3000	400~3000
5 th Stitch	3000	400~3000

Setting Example: In case of with needle thread clamp, the speed is changed as follows.

1st stitch form 1,500 to 1,000 rpm and 2nd stitch form 3,000 to 2,000 rpm.

1) Press  in the state that the sewing LED is put out.







2) Indicate memory switch No.2 with  or  key. Here, set the sewing speed of the first stitch.

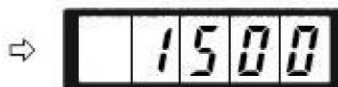

3) Press  key. The sewing LED lights up and the set value of the first stitch is indicated.



4) Indicate “1000” with  or  key. The value returns to the initial value at the time of delivery from the factory with  key.



Press  key to cancel the operation here and

return to the state of step 2).



- 5) Press  key. The sewing LED goes off and the set value of the first stitch is registered.







- 6) Indicate memory switch No.3 with  or  key. Here, set the sewing speed of second stitch.



- 7) Press  key. The sewing LED lights up and the set value of the second stitch is indicated.



- 8) Indicate “2000” with  or  key. The value returns to the initial value at the time of delivery from the factory with . Press  key to cancel the operation here and return to the state of step 6).



- 9) Press  key. The sewing LED goes off and the set value of the second stitch is registered.

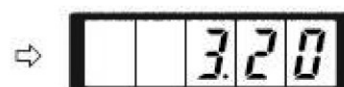

- 10) Press  key. The memory switch setting mode is finalized and the mode

returns to the normal mode.

3. Setting Whether the Calling of Pattern Data is Operative or Not

By making inoperative the calling of the unnecessary pattern, this setting prevents the different pattern from calling by mistake.

Also, it is possible to call and use the necessary pattern.

Setting Example: Make the calling of pattern Nos.2 and 3 inoperative.

- 1) Press  key in the state that the sewing LED is put out.



- 2) Indicate memory switch No.201 with  or  key.

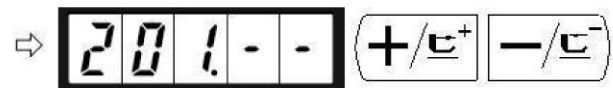

- 3) Press  key. The sewing LED lights up and the set value of pattern No.1 is indicated.

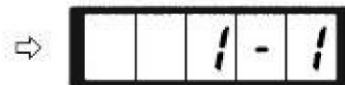



Set value 1: Calling is operative.

Set value 0: Calling is inoperative.

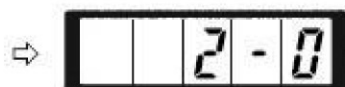
- 4) Set pattern No.2 with  or  key



- 5) Set the set value to "0" with  key.

- 6) Set the pattern No.3 with  or  key.

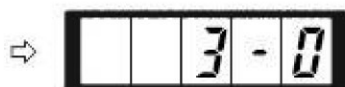

- 7) Set the set value to "0" with  key.

- 8) Press  key to register the set value. The



- 9) Press **M** key. The memory switch setting mode is finalized and the mode returns to the normal mode.

4. Setting the Counter Operation

Setting Example: The production counter (adding method) can be changed to the bobbin thread counter (subtracting method).

- 1) Press **M** key in the state that the sewing LED is put out.



- 2) Indicate the memory switch No.18 with **+ / C⁺** or **- / C⁻** key.



- 3) Press key. The sewing LED lights up and the set value of counter motion is indicated.



- 4) Set the set value to "1" with **+ / C⁺** key.

Set value 0: Production counter

Set value 1: Bobbin thread counter



- 5) Press key to register the set value. The sewing LED goes off.

- 6) Press **M** key. The memory switch setting mode is finalized and the mode returns to the normal mode.

2.6.3 Table of Functions of the User Class Memory Switch

Indication	Function	Setting Rang	State When Delivered	Remarks

		1.	3	0	Max. sewing speed (speed can be set in a unit of 100 rpm)	400~3000	3000	
		2.	1	5	Sewing speed of 1 st stitch (With needle thread clamp) (speed can be set in a unit of 100 rpm)	400~1500	1500	
		3.	3	0	Sewing speed of 2 nd stitch (With needle thread clamp) (speed can be set in a unit of 100 rpm)	400~3000	3000	
		4.	3	0	Sewing speed of 3 rd stitch (With needle thread clamp) (speed can be set in a unit of 100 rpm)	400~3000	3000	
		5.	3	0	Sewing speed of 4 th stitch (With needle thread clamp) (speed can be set in a unit of 100 rpm)	400~3000	3000	
		6.	3	0	Sewing speed of 5 th stitch (With needle thread clamp) (speed can be set in a unit of 100 rpm)	400~3000	3000	
		7.	-	-	Thread tension of 1 st stitch (With needle thread clamp)	0~200	200	
		8.	-	-	Thread tension at the time of thread trimming	0~200	0	
		9.	-	-	Changeover timing of thread tension at the time of thread trimming	-6~4	0	
1	0.			4	Sewing speed of 1 st stitch (Without needle thread clamp) (Speed can be set in a unit of 100 rpm)	400~1500	400	
1	1.			9	Sewing speed of 2 nd stitch (Without needle thread clamp) (Speed can be set in a unit of 100 rpm)	400~3000	900	
1	2.	3		0	Sewing speed of 3 rd stitch (Without needle thread clamp) (Speed can be set in a unit of 100 rpm)	400~3000	3000	
1	3.	3		0	Sewing speed of 4 th stitch (Without needle thread clamp)	400~3000	3000	

				(Speed can be set in a unit of 100 rpm)			
1	4.	3	0	Sewing speed of 5 th stitch (Without needle thread clamp) (Speed can be set in a unit of 100 rpm)	400~3000	3000	
1	5.	-	-	Thread tension of 1 st stitch (Without needle thread clamp)	0~200	0	
1	6.	-	-	Changeover timing of thread tension at the sewing start (Without needle thread clmap)	-5~2	0	
1	7.		0	X/Y scale enlargement, Max.speed whether could be changed	0: Yes 1: No	0	
1	8.		1	Counter Operation	0: Production Counter (adding) 1: Bobbing thread counter (subtracting)	0	
3	1.		0	Sewing machine operation can be stopped with panel key (clear key)	0: Ineffective 1: Panel reset key	0	
3	2.		1	Buzzer Sound	0: Without buzzer sound 1: Panel operation sound	1	
3	3.		2	Number of stitches that needle thread clamp releases is set.	1~7 stithces	2	
3	4.	-	-	Clamping timing of needle thread clamp can be delayed.	-10~0	0	Timing is delayed in“-” direction
3	5.		0	Needle thread clamp control can be prohibited.	0: Normal 1: Prohibited	0	
3	6.	-	-	Feed timing is selected.	-8~16	12	Setting on excessive “-” side may cause needle breakage. Be careful when sewing heavy-weight material.
3	9.		0	Execution of origin retrieval every time after completion of sewing	0: Without origin retrieval	0	

						1: With origin retrieval		
	4	0.		0	Setting of origin retrieval in cycle stitching	0: Without origin retrieval 1: Every time 1 pattern is complete	0	
	4	2.		0	Needle bar stop position is set	0: Up position 1: Upper dead point	0	Needle bar rotates in the reverse direction after the UP position stop and stops when upper dead point stop is set
	4	6.		0	Thread trimming can be prohibited.	0: Normal 1: Prohibited	0	
	4	9.	1	6	Bobbing winding speed	800~2000	1600	
2	0	1.	-	-	This function sets whether or not the calling of the pattern data is operative.	0: Calling inoperative 1: Calling operative	Setting depends on the model used	Service pattern Nos. 1 to 64 can be individually set.
P	-	-	-	-	Register of the pattern is performed			
C	-	-	-	-	Register of the cycle stitching is performed			

3. Memory Switch (Service Class)

Service class memory switch is different from the user class and it is not allowed to be changed by users. We provide these functions to the professional for adjustment and maintenance.

3.1 Start and Change of the Memory Switch (Service Class)

When  key is pressed in the state that the sewing LED is put out, the memory switch setting mode is obtained and

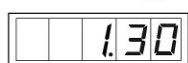

is indicated. Then press

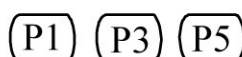

simultaneously, and you will hear the buzzer ring. After that you have started the memory switch and you are allowed to change the settings.

The operation of service class memory switch is the same as that of user class memory switch. Refer to **【2.6 How to Use the Memory Switch (User Class)】** for details.

3.2 Table of Functions of the Service Class Memory Switch

Indication	Function	Setting Range	State When Delivered	Remarks
21.--	Position of Standard Pedal Step 1	50-500	140	The stroke of depressing the pedal will be large if increase the value.
22.--	Position of Standard Pedal Step 2	50-500	240	The stroke of depressing the pedal will be large if increase the value.
23.--	Starting Position of Standard Pedal	50-500	370	The stroke of depressing the pedal will be large if increase the value.
27.--	Speed of Lowering Presser	100-4000pps	4000	
28.--	Speed of Lifting Presser	100-4000pps	1500	It will cause poor sewing if this value is set too high.
29.--	Speed of Trimming • Presser after Sewing	100-4000pps	3000	It will cause poor sewing if this value is set too high.
37.0	Presser Status after Sewing	0: Lift Up 1: Depress Pedal to Lift Up the Presser	0	

38.0	Presser don't lift and depress pedal to sewing	0: usual 1: Presser don't lift	0	
43.1	Speed Choice When Trimming	0: 400rpm 1: 800rpm	1	Speed of moving knife spreading the thread; the trimming is performed after the machine stops.
44.1	Feeding Cloth When Trimming at the Direction of Easy Trimming	0: No 1: Yes	1	
45.16	Diameter of Thread Guider when Feeding at the time of Trimming	16-40 (1.6mm-4.0mm)	16 (1.6mm)	Amount of feeding will be more if the value is set larger
47.0	Prohibit Trimming	0: Normal 1: Prohibited	0	Prohibit all trimming operation.
52.--	Conduction Time of Wiper Solenoid	10-500ms	50	Valid only wiper solenoid is chosen.
53.--	Release Time of Wiper Solenoid	10-500ms	100	Valid only wiper solenoid is chosen.
56.--	+X Direction (R) Shifting Range	-20-20mm	20	Not consider the shape of Presser when delivered.
57.--	-X Direction (L) Shifting Range	-20-20mm	-20	Not consider the shape of Presser when delivered.
58.--	+Y Direction (B) Shifting Range	-20-10mm	10	Not consider the shape of Presser when delivered.
59.--	-Y Direction (F) Shifting Range	-20-10mm	-20	Not consider the shape of Presser when delivered.
62.0	Perform READY when Power ON	0: Normal 1: Perform READY when Power on	0	
67.--	Main Control Software Version	0 或 1	1	Refer to 【3.3 Restore Default Setting】
68.--	Stop Position Compensation	-10-+10	0	
150.0	Set the Safety Switch to be Invalid	0: Normal 1: Invalid	0	
241.0	Machine type	0: reinforcement 7: Lockstitch Button	0	Refer to chapter 4.1

The functions above assumes for special repair or maintenance.

3.3 Restore Default Setting

When the users change the settings by accident, or the control system fails to work, you could try to restore the default setting.

Attention: Please be very careful when you decided to restore the setting, for the former setting will be replaced. If you get any question about this, please contact the technology support for help and conduct the default setting following his or her instruction.

Follow this steps to restore the default setting:

- 1) When **M** key is pressed in the state that the sewing LED is put out, the memory switch setting mode is obtained and **P1 P3 P5** is indicated. Then press **1.30** simultaneously, and you will hear the buzzer ring. After that you have started the memory switch and you are allowed to change the settings.
- 2) Press **+ / ⏪** or **- / ⏩** key to select function NO.67:

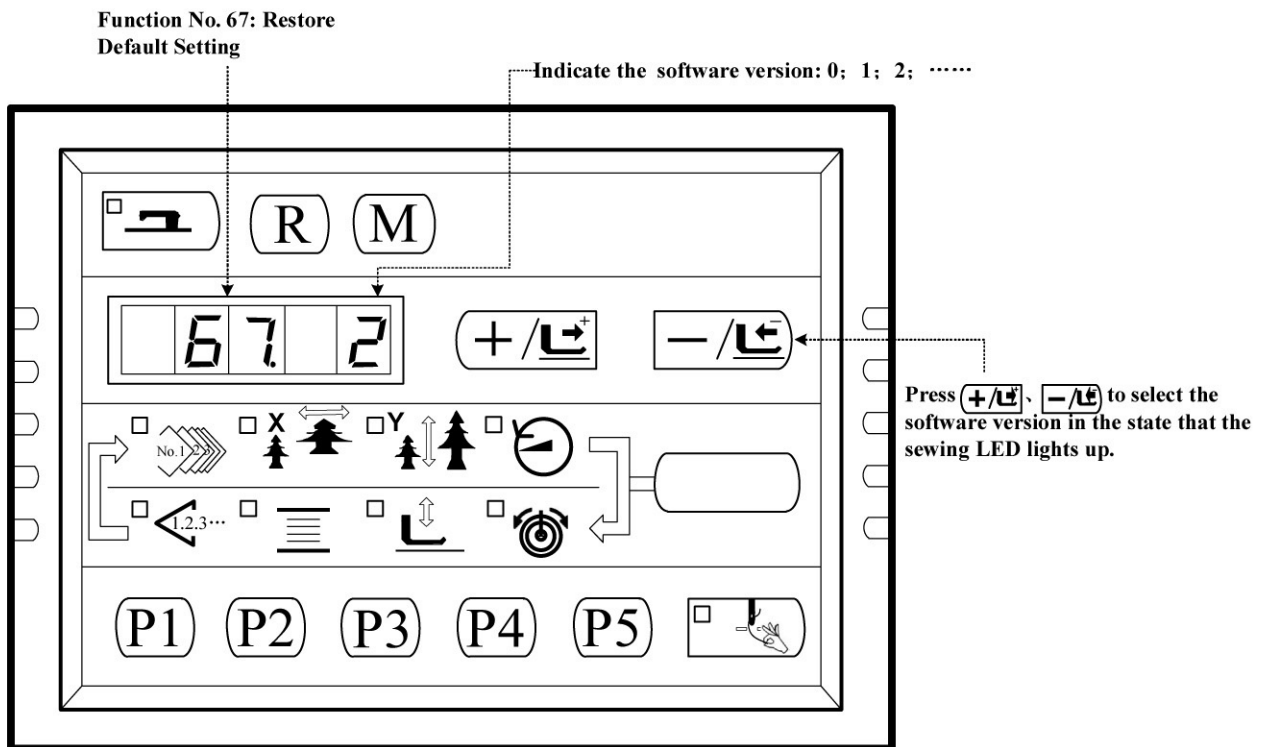

- 3) Press **⏪** key to light up the sewing LED. Then press **+ / ⏪** or **- / ⏩** key to select the software version:

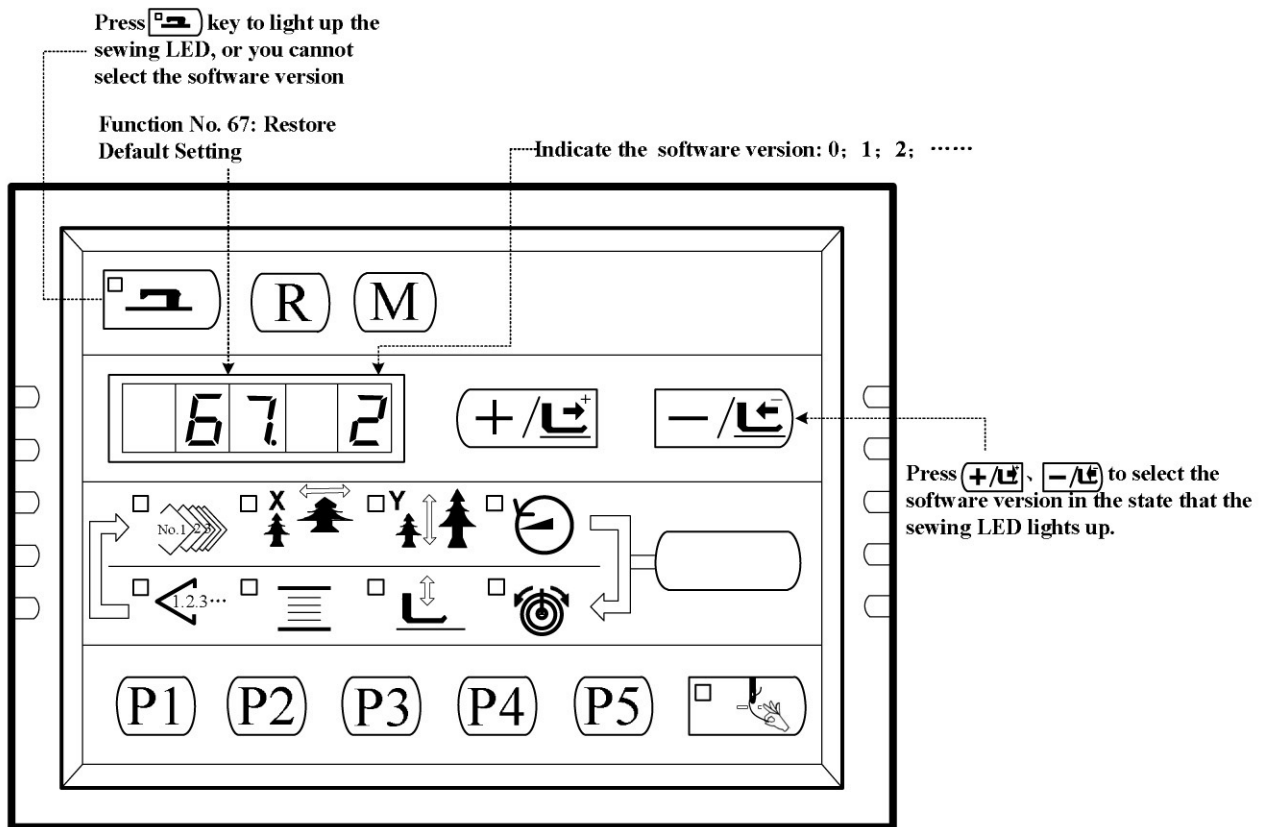

- 4) For instance, the present software version is 2, then you can chose version 1 or 0 for restoring. The version you chose for restoring must be lower than the present software version.. Press key to confirm and the sewing LED goes off.
- 5) Press key to exit and return to the normal state.
- 6) Power off. 1 minute later, turn ON the power and wait for 20 seconds. The restoring process will automatically starts up. Then the screen lights up to indicate that the process is finished.
- 7) After restoring, the present software version will automatically change to be the highest. For example, the default software version is 0 and 1, and after restoring, the present software version will be 2 in order to keep the default software version number.

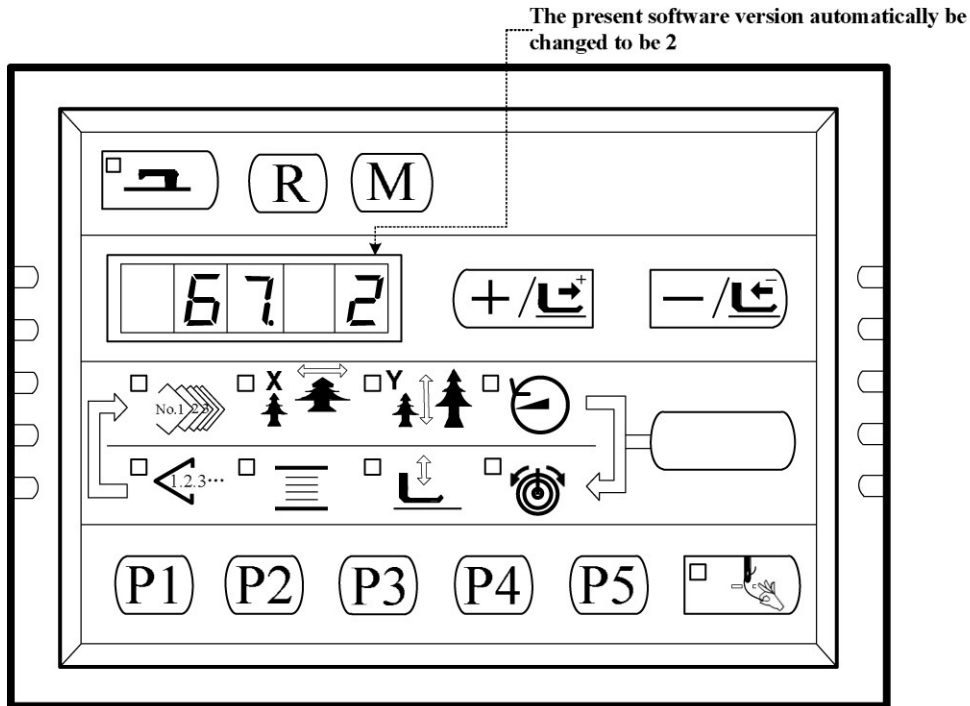





Note: During the restoring process (20 seconds after power on), if the power is cut by accident, the restoring process has to be aborted and you failed to restore the default setting. The software will return to the former state before restoring.

4. Lockstitch Button Sewing Function

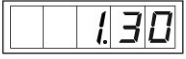
4.1 Lockstitch Button Sewing Function Setting

- 1、 Press  key, while the Sewing LED is not illuminated, and then the Panel display

. Press    simultaneously, you would hear the ring of the buzzer, and then you are able to adjust the setting.

- 2、 Press 、 key to select No.241:

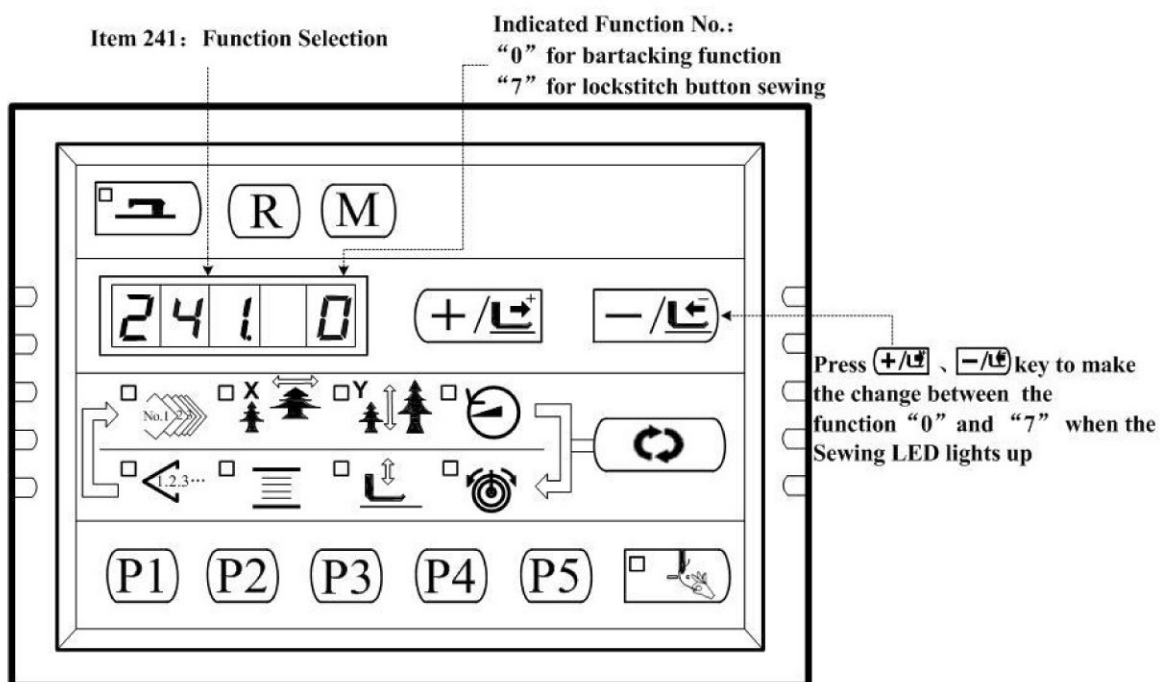































- 3、 Press  key to light up the sewing LED, and then press  or  key to



change the Function NO. to “7”. Press  key again to save the setting and the Sewing LED goes off.

- 4、 Press  key to exit and Power off. Power on, and the machine has changed to be a lockstitch button sewing machine.

Attention: The lockstitch button sewing function need particular Presser, for details, please contact your machine agent.

4.2 Table of the Lockstitch Button Sewing Patterns

No.	Stitch Shape	Threads	Sewing Size X(mm)	Sewing Size Y(mm)	No.	Stitch Shape	Threads	Sewing Size X(mm)	Sewing Size Y(mm)		
1 • 34		6-6	3.4	3.4	18 • 44		6	3.4	0		
2 • 35		8-8			19 • 45		8				
3		10-10			20		10				
4		12-12			21		12				
5 • 36		6-6			22		16				
6 • 37		8-8			23 • 46		6			0	3.4
7		10-10			24		10				
8		12-12			25		12				
9 • 38		6-6			26 • 47		6-6				
10 • 39		8-8			27		10-10				
11		10-10			28 • 48		6-6				
12 • 40		6-6			29		10-10				
13 • 41		8-8			30 • 49		5-5-5			3.0	2.5
14		10-10			31		8-8-8				
15 • 42		6-6			32 • 50		5-5-5				

No.	Stitch Shape	Threads	Sewing Size X(mm)	Sewing Size Y(mm)	No.	Stitch Shape	Threads	Sewing Size X(mm)	Sewing Size Y(mm)
16 • 43		8-8			33		8-8-8		
17		10-10							

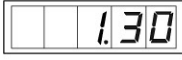

5. Update the Pattern Data by USB Flash

5.1 Pattern Data Update

1、 Press **(M)** key, while the Sewing LED is not illuminated, and then the Panel display . Press **(P1)** **(P3)** **(P5)** simultaneously, you would hear the ring of the buzzer, and then you are able to adjust the setting.

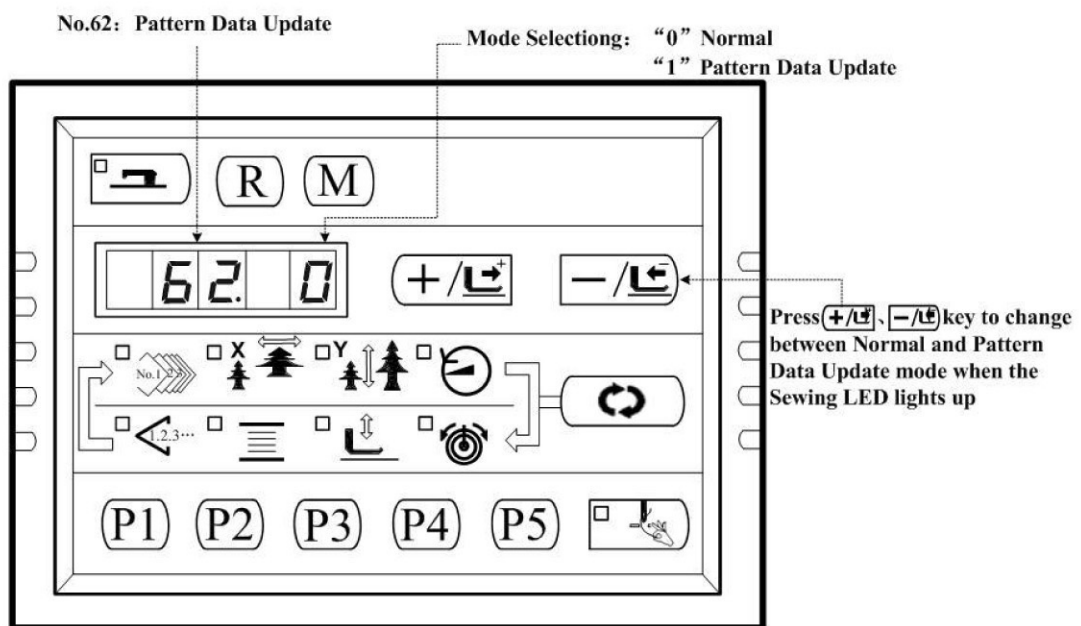
2、 Press **(+/-)**、 **(-/-)** key to select No.62:



3、 Press  key and the Sewing LED lights up. Then press **(+/-)**、 **(-/-)** key to change the Mode Selection No. to be "1" (Pattern Data Update); press  key again to save the setting and the Sewing LED goes off.

4、 Turn OFF the power and put out the Panel form interface X7, and plug the Pattern Update Device as following:

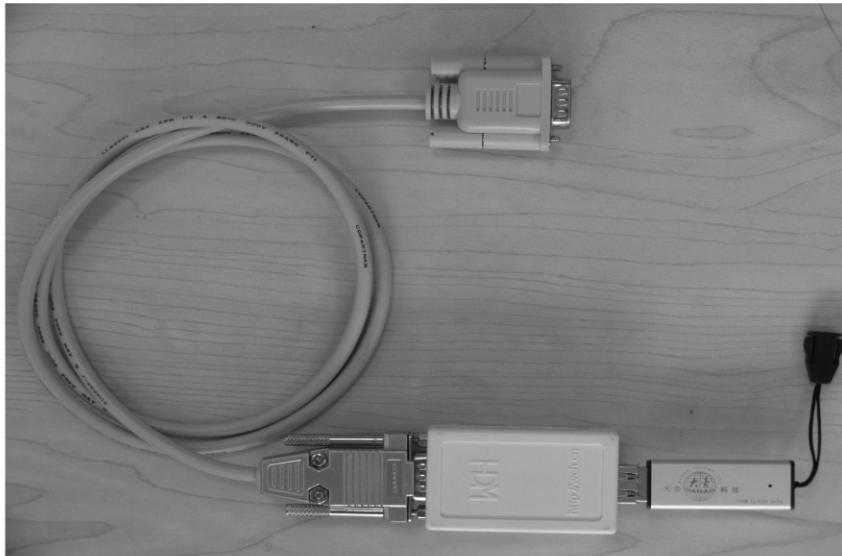

- 5、 Store your pattern data file in the folder named "DH" under the root directory of your USB Flash Disk. Power on and the computerized controller will automatically update your pattern data into the system memory disk., arranging form 101 to 200, and simultaneously it will backup the pattern data arranging form 101 to 200 in your old system, if there is, to a file named"DHBAK.bin"(if there is no pattern data form 101 to 200 then the DHBAK.bin file would be empty). During the updating process, please don't pull out the Pattern Update Device. After updating, the buzzer will ring once to indicate it is successfully finished.
- 6、 Turn OFF the power and pull out the Pattern Update Device. Plug the Panel again and Power on.





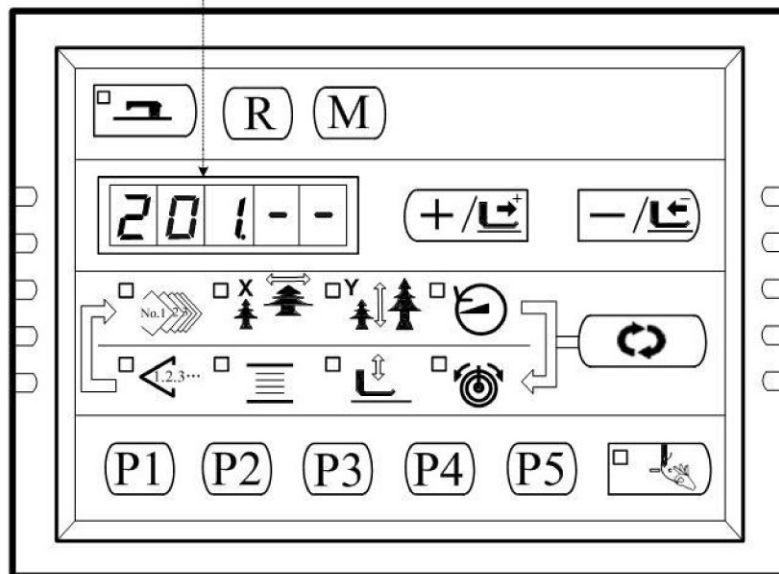

Press **(M)** key to display **1.30** and then press **(+/-⁺)**, **(-/-⁻)** key to select No.201:

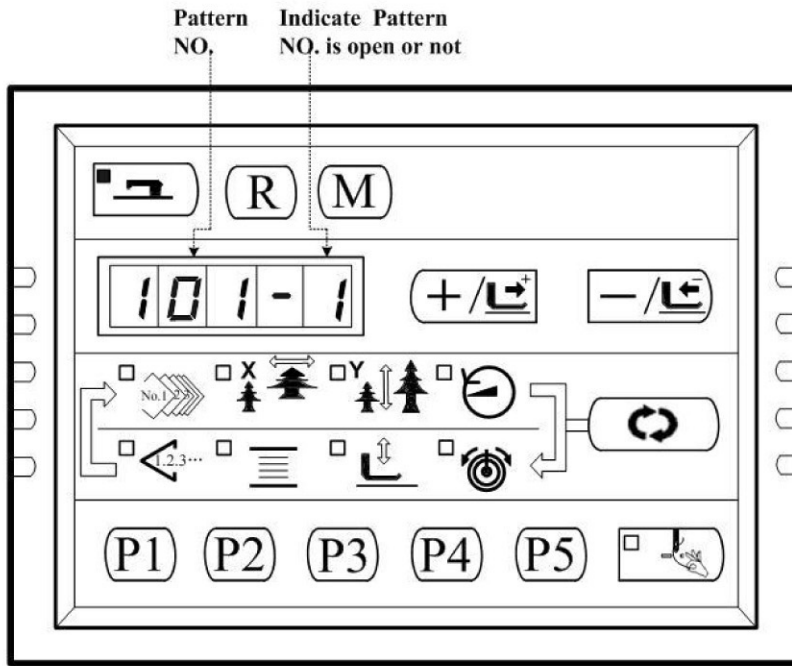
No. 201: Pattern Read Switch



- 7、 Press **(No.1)** key to enter Pattern Read Switch mode and the Sewing LED lights up. "1-1" is indicated.



- 10、 Press  key to save the settings and Sewing LED goes off and return to Step 6; repeat the operation from step 6 to step 10 again and again to open or lock all the patterns you want.
- 11、 Press  key to go exit to Normal state.
- 12、 Press  key to select Pattern NO. , and then press ,  key to get Pattern No. 101, which is opened. Then you are able to start sewing with it.

6 Appendix 1

6.1 Error List

Indication	Name of the Error	Description of the Error	Corrective Message
E 7	Machine Lock Error	The main shaft of the sewing machine doesn't rotate due to some trouble.	Check the six-channel PWM signal on the MD 301 Driver Board or the responsive signal from the main servo motor encoder; turn OFF the power and remove the cause of the trouble
E 10	Pattern No. Error	Back-up pattern No. has not been registered in the data ROM, or it is set to readout inoperative. Pattern No. is set to "0" .	Press the Reset and check the pattern No. Check the contents of memory switch No.201.
E 30	Needle Bar Up Position Error	Needle Bar is Out of the Needle Up Position	Turn the hand pulley to return the needle bar to its UP position.
E 40	Sewing Area Error	The sewing area is beyond the limit.	Press Reset and check the pattern and X/Y scale rate.
E 43	Enlargement Error	The sewing pitch is beyond 10mm.	Press Reset and check the pattern and X/Y scale rate.
E 45	Pattern Data Error	The pattern data cannot be adopted.	Turn OFF the power and check the data ROM.
E 50	Temporary Stop	Temporary stop by operating the Reset while sewing machine is running.	Re-start or return-to-origin after thread trimming by pressing Reset.
E 221	Grease Replenishing Warning Error	Sewing machine has stopped since the time of replenishing the designated place with grease has come.	Immediately perform replenishing with grease and set the memory switch No. 245 to "0" with Reset.
E 302	Head Tilt Error	Head tilt detection switch is turned ON.	The sewing machine cannot be operated with the head tilted. Or you can short circuit the blue 2P coupling on SC202B with a short circuit block.
E 303	24V Power Supply Error	The 24V power voltage is too low	Turn OFF the power for a while and then Turn ON the power again.

E 305	Work Clamp Foot Position Error	The work clamp foot is not in the proper position.	Turn OFF the power and check whether X9 circuit is disconnected or loose.
E 306	Thread Clamp Position Error	The needle thread clamp device is not in the proper position.	Turn OFF the power switch and check whether CZ026 is disconnected or loose.
E 730	Encoder Cable Not Connected	Not be able to detect ADTC signal	Turn OFF the power and check whether X5 circuit is disconnected or loose.
E 731	Communication between the Main Board and Step Driver Board Error	Communication interferes.	Turn OFF the power and remove the cause.
E 733	Overcurrent of Main Servo Motor	The motor stops.	Make sure that the machine is not locked, and then check weather the Encoder cable is connected well.
E 811	Overvoltage Error	Power source voltage is beyond the specified value	Check the power source voltage
E 813	Low Voltage Error	Power source voltage is short	Check the power source voltage
E 901	Main Servo Motor Driver Trouble	Error form the driver is detected.	Turn OFF the power and turn ON the power again after some time.
E 903	Stepping Motor power source trouble.	The current of the stepping driver board is over current.	Turn OFF the power and turn ON the power again after some time.
E 904	24V Power Supply Trouble	Over current.	Turn OFF the power and turn ON the power again after some time.
E 906	Main Servo Motor Out of Control	Main Servo Motor Out of Control	Turn OFF the power and turn ON the power again after some time.
E 907	X Origin Retrieval Error	X origin sensor does not change	Turn OFF the power supply and check whether X9 coupling is disconnected or loose.
E 908	Y Origin Retrieval Error	Y origin sensor does not change	Turn OFF the power supply and check whether X9 coupling is disconnected or loose.

E 910	Work clamp foot Origin Retrieval Error	Work clamp foot origin sensor does not change.	Turn OFF the power switch and check whether CZ025 and coupling X9 are disconnected or loose.
E 913	Needle Thread Clamp Origin Retrieval Error	Needle thread clamp sensor does not change.	Turn OFF the power switch and check whether CZ026 and coupling X9 are disconnected or loose.
E 914	Feed Trouble Error	Timing lag between feed and main shaft has occurred.	Turn OFF the power and check whether coupling of the main motor is loose.
E 915	Communication Error between Panel and Main Board	Communication between the Panel and Main Board cannot be performed.	Turn OFF the power and turn ON the power again after some time Check the panel, communication cable and the main board.
E 916	Communication Error between Main Board and Step Motor Driver MD301	Communication between the Main Board and the Step Motor Driver MD301 cannot be performed.	Turn OFF the power and turn ON the power again after some time Check the Main Board, communication cable and the Step Motor Driver MD301.
E 943	The Main Board and EEPROM Read/Write Error	EEPROM read or write of Main Board cannot be performed.	Turn OFF the power and turn ON the power again after some time. Check the footprint 26\27 whether be cut off.

7 Appendix 2

7.1 Installation Size of Control Box

At present, there are three kinds of installation methods for the computerized controllers of our company, which are 4-hole installation and 3-hole installation. For the detailed size, please refer to the picture as below:

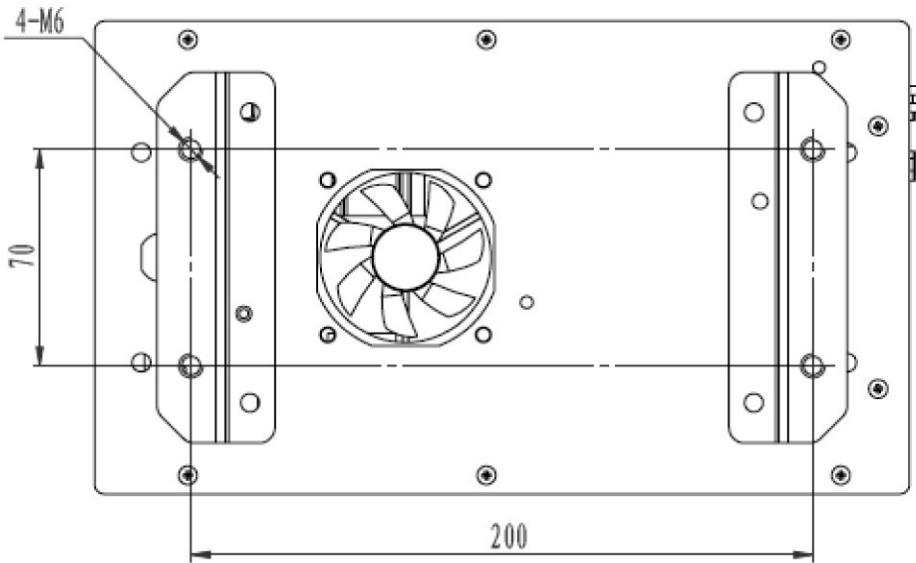

Figure 1 Size of 4-hole Installation

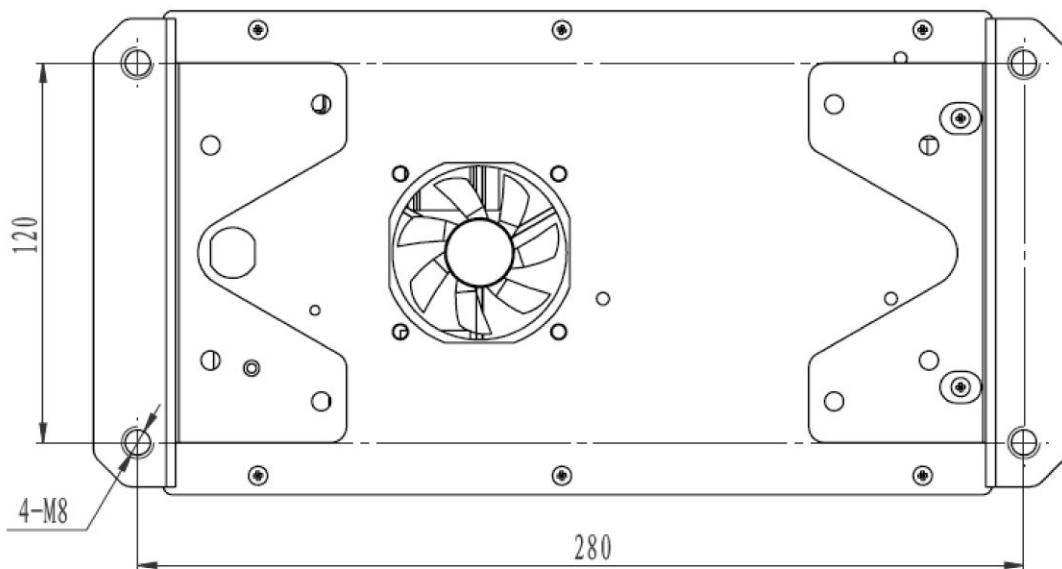

Figure 2 Size of 4-hole Installation

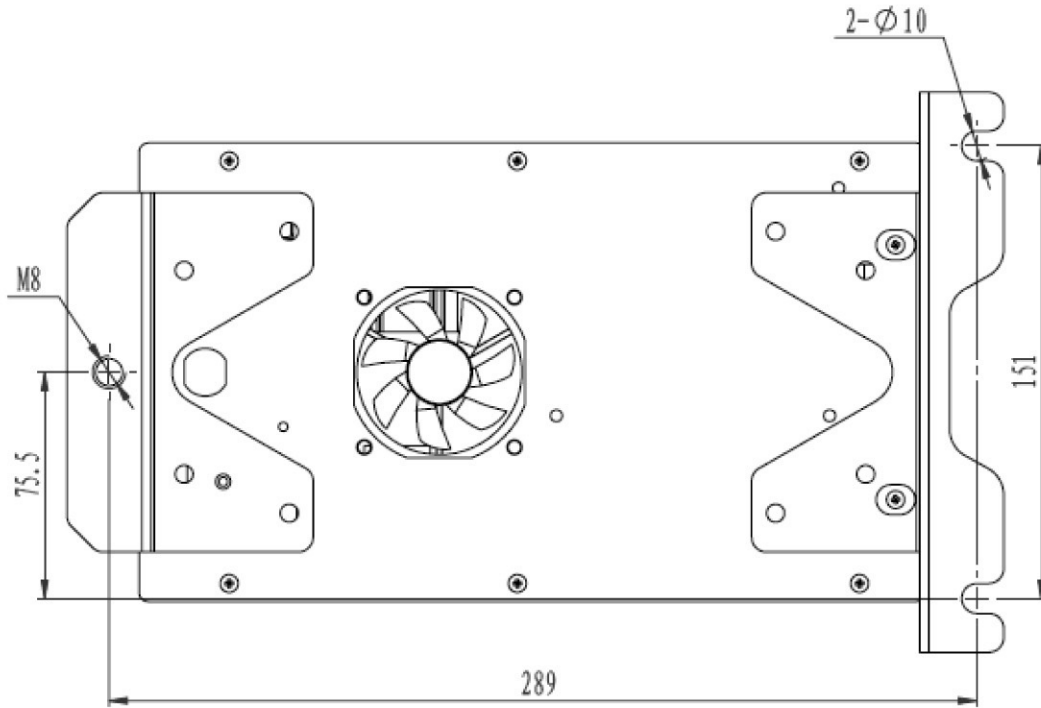

Figure 3 Size of 3-hole Installation

7.2 Installation Size of Operation Box

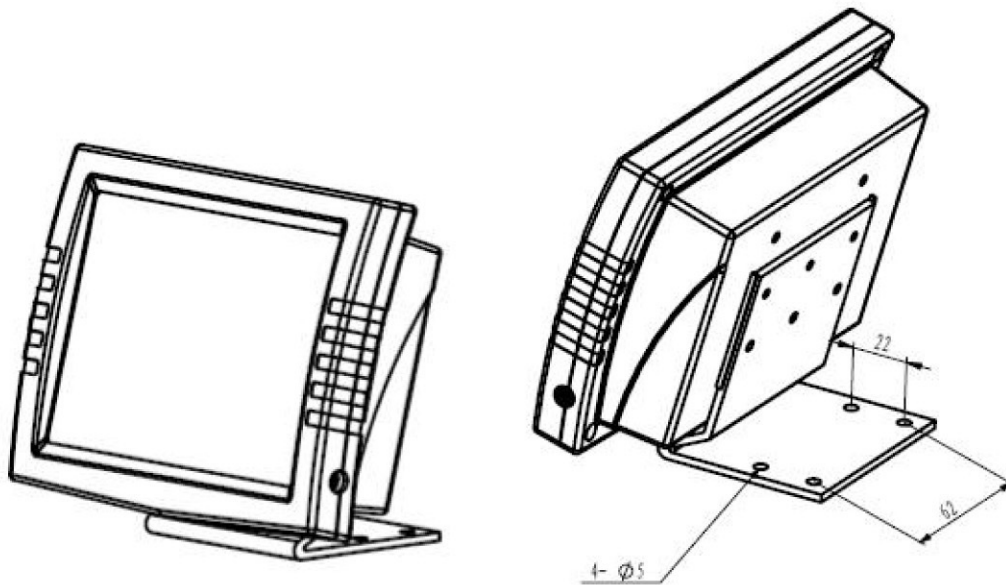

Figure 4 Installation Size of Operation Box

7.3 Diagram of Connection of the External Cable and Control Box

Please check the corresponding symbol on both the external cable and control box. Follow the symbol to make the connection.

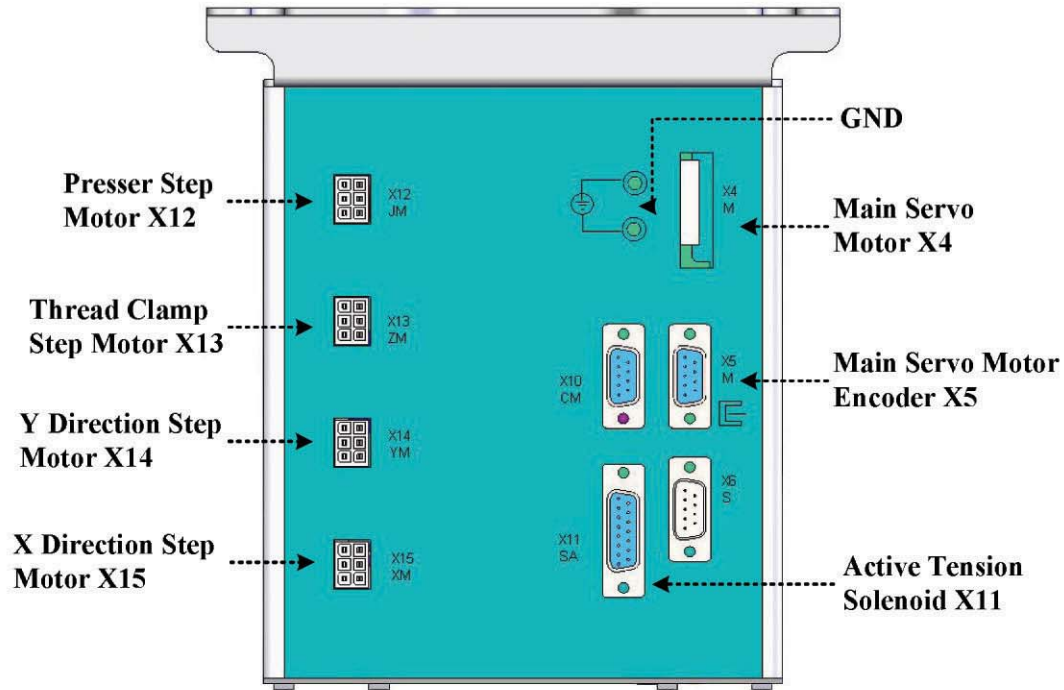

Figure 5

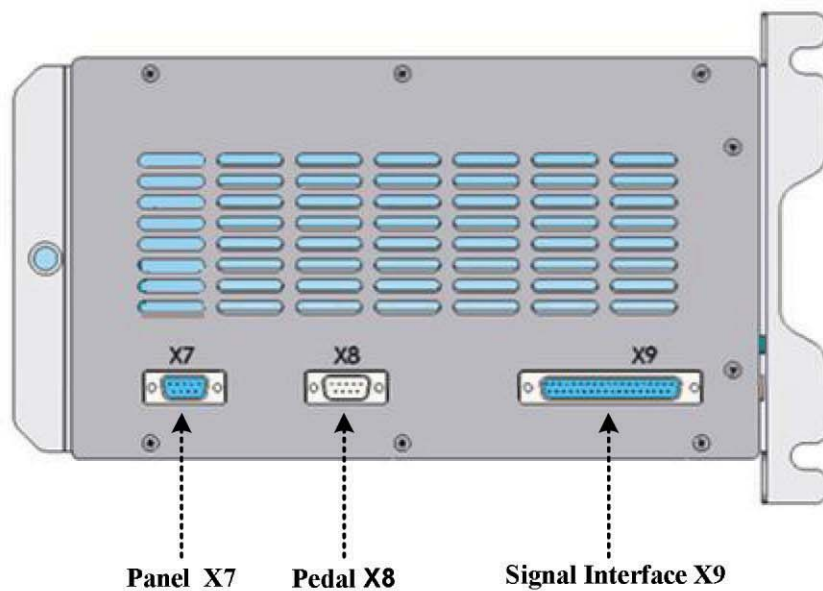
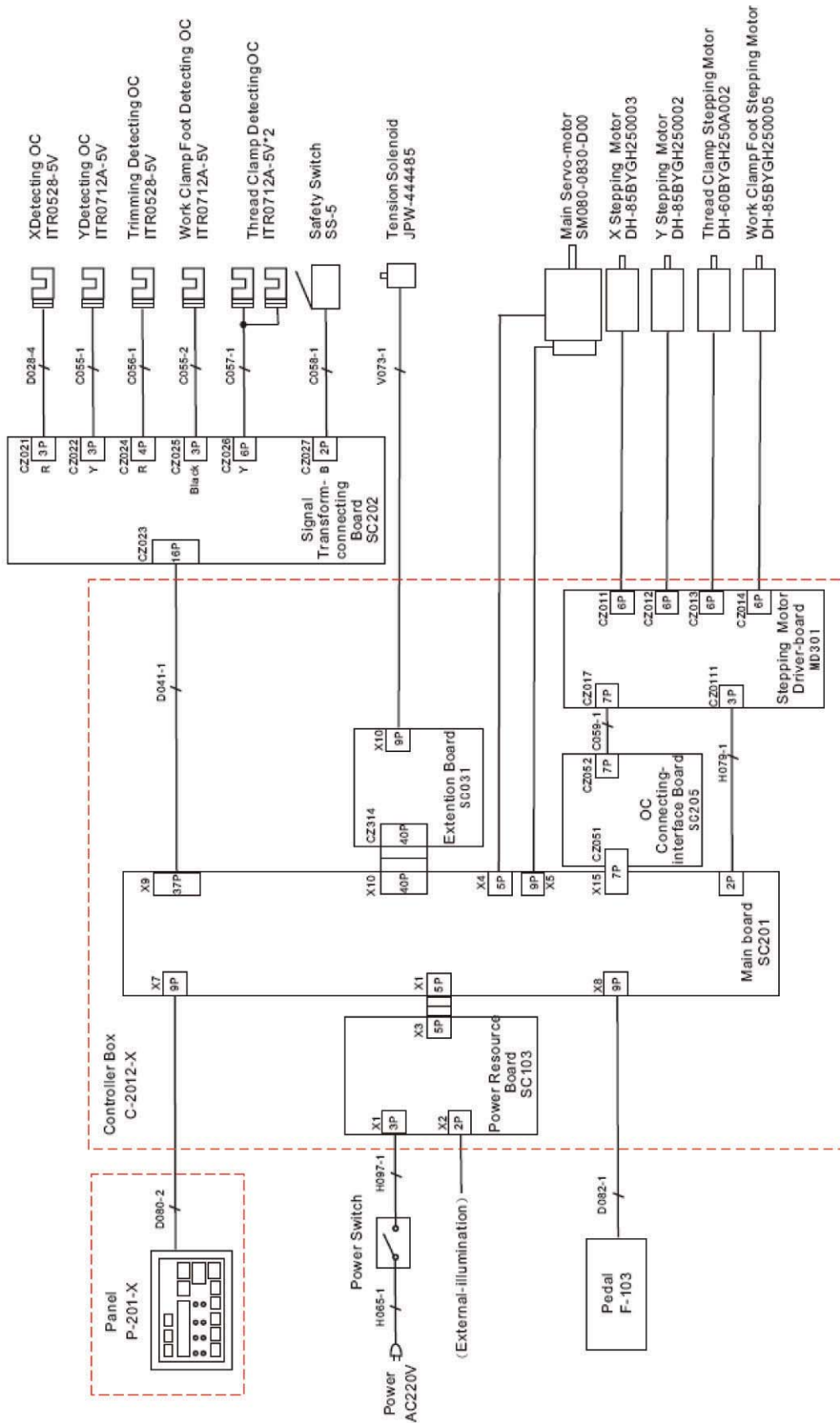

Figure 6

7.4 UAS-H900D_{SERIES} Control System Diagram



M

Unicorn®

UAS-H900D SERIES

UNICORN MACHINE INDUSTRIES Corp.

HEAD OFFICE

No. 588-21, SHINSA-DONG, KANGNAM-KU, SEOUL, KOREA

TEL : 82-2-3446-4083 / FAX : 82-2-3446-5144

유니콘미싱공업(주)

서울시 강남구 신사동 588-21

TEL : 82-2-3446-4083 / FAX : 82-2-3446-5144

부산공장

부산시 사하구 다대동 1521-2

TEL : 051-265-3301/5