



# WS-8700/DDDL-9000B

# Operation Manual

---



Shanghai Weishi Mechanical CO. LTD.

Address: 52#, No.1089, North Qinzhou Road, Shanghai

Postal Code: 200233

Phone: 64953003, 64958277, 64955983; Fax: 64957015

# Preface

This manual is written for technical service staffs and operating personnel.

In the Operation Manual for sewing machine preservers in the garment factory and the sewing operators, we have made a thorough explanation on how to use this sewing machine. So in this Service Manual, we will make some explanations on particular and relevant functions, on the adjustment methods for compiling, on the phenomenon resulted from changes in value and other various functions.

In addition to this manual, please refer to other Operation Manuals and parts list when preserving and repairing this machine.

## For a safe adjustment operation.

Before adjusting the sewing machine, the automatic machine and the appendant devices (hereinafter called the machine), the operator should read the machine's "Important Safety Instructions" carefully and understand it fully.



The "Important Safety Instructions" in this Service Manual explains some items which are not included in the machinery specification you bought.

Besides, in order to make you fully understand this Service Manual and the warning signs stickup in the machine body, the warning signs are used separately according to the following descriptions.





You should fully understand and consciously comply with its contents.

Adjustments: Parts' replacement, removal, repair, assemble and other operations.

### (1) Descriptions about the dangerous level

 <b>Danger</b>	When operating and maintaining the machine, the dangerous parts which could cause death or serious injury by the third person's misoperation and the privies couldn't avoid.
 <b>Warning</b>	The potential parts which could cause death or serious injury by the third person's misoperation and the privies couldn't avoid when operating and maintaining the machine.
 <b>Caution</b>	The parts which could cause moderate or minor injury by the third person's misoperation and the privies couldn't avoid when operating and maintaining the machine.

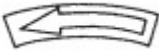
### (2) Descriptions about the indications of the warning patterns

Warning patterns		Moving Parts: be cautious of the industrial accident.	Indication Sign		Belt Drive: be cautious of the industrial accident.
		High Voltage Parts: be cautious of electric shock.			Indicate the correct direction of rotation
		High Temperature Parts: be cautious of scalding accident.			Indicate the earth wire that should be earthed.

---

## Important Safety Instructions

Accident: Refers to the physical and property damage.

Cut off the power: Refers to turn off the power switch and pull out the power plug from the socket.



### Danger

To prevent the electric shock, when it is necessary to open the electrical cabinet, please cut off the power first and then open the electrical cabinet after at least 5 minutes.



### Caution

#### Basic

1. To prevent human injury, please read and understand this Service Manual before operating. Besides, in order to use this Service Manual easily at any time, please keep it properly.
2. To prevent accidents caused by accidental start, please cut off the power before making any adjustment. When it has to operate with the power on, please do not step on the pedal or press the start button. When leaving the machine, it is necessary to cut off the power.
3. To prevent human injury, please verify whether the connecting terminal, cable and other thins are damaged, loosen and so on after making adjustments.

#### Education

1. To prevent human injury when adjusting the operation, the person who is responsible should be taught about the latest information and safety knowledge, and be trained to operate according to this Service Manual and the Operation Manual.

#### Mechanical

1. To prevent the accidents caused by misadjustments, the adjustment should be made according to this Service Manual and the Operation Manual by the maintenance technician who is familiar with mechanistic relations and has been trained about the safety knowledge.
2. Please use the genuine components made by our company when replacing components. Our company shall not bear the responsibility for the incidents caused by inappropriate adjustment and for the using of the components which are not made by our company. If the adjustment can't be made within the range of indication, you should terminate the repairing work immediately and authorize the technician in our company or in the agency shop to solve.
3. To prevent human injury, please verify whether the screws and nuts are loose after making adjustment.

4. To prevent human injury, when unexpected things happen during adjustment or machine still can't work normally after adjustment, please stop operating immediately.
5. To prevent human injury, when adjusting, the safety devices removed or damaged should be installed at its original place and verify whether they are normal and valid.
6. To prevent human injury, the warning signs stickup in the machine should be able to see clearly at any time. When they are desquamated or contaminated, you should replace a new one immediately.

#### **Electrical**

1. To prevent accidents and electric shock, please authorize the specified person with electrical knowledge or the technician in our company or in the agency shop to make the adjustment.
2. To prevent human injury, if the fuse blows out, please cut off the power, find out the cause, eliminate the trouble, and then replace a new fuse with the same capacity (specification).
3. To prevent human injury, please verify whether the connecting terminal, cable and other things are damaged, loose and shed after making adjustments.

#### **Air-pressure**

1. To prevent accidents caused by accidental start, when using air cylinder and other air-pressure components to make adjustment, please cut off the air supply and drain the internal compressed air first.
2. To prevent accidents caused by faulty action, please verify whether there is water in cylinder and air tube.

#### **Mechanical adjustment in clutch motor**

1. After cutting off the power, the clutch motor will continue to spin because of its inertia. To prevent human injury, please start to adjust after verifying the motor has stopped.

#### **Mechanical application and transformation**

1. To prevent human injury, do not make any adjustment or transformation which is not complied with the specifications of the machine. Our company shall not bear any responsibility for the accidents caused by such adjustment or transformation.
2. To prevent human injury, do not operate exceeding the machine's using range or the usage specified in this Service Manual and the Operation Manual. Our company shall not bear any responsibility for the accident caused by such operation.



## Caution

### Move

- 1、 To prevent human injury, please use two or more than two persons to lift this machine and use a moped to move it.
- 2、 To prevent human injury, please adopt sufficient safety precautions to prevent accidental drop and turnover when lifting or moving.
- 3、 We have made a thorough explanation about the installation in the Operation Manual, please read carefully and fully understand before operating.

### Component Replacement

- 1、 To prevent human injury, please replace the component under the direction of this Service Manual and the Operation Manual.
- 2、 To prevent occupational injury and human injury, please operate after cutting off the power.
- 3、 To prevent human injury, please operate after the machine has been installed steadily. Meanwhile, it is necessary to choose appropriate tools.
- 4、 To prevent human injury, please verify whether the screws and nuts are loose, whether they have unexpected contact with other components after finishing operation.
- 5、 Please use the genuine components made by our company to replace.

Our company shall not bear any responsibility for the accidents caused by the using of the components which are not by our company.

If you couldn't replace the components normally under the direction, please stop repairing and contact with the technicians in our company or the agency shop.

### Adjustmen

- 1、 To prevent human injury, please make adjustments within the range indicated in this Service Manual and the Operation Manual.
- 2、 To prevent human injury, please operate after the machine has been installed steadily. Meanwhile, it is necessary to choose appropriate tools.
- 3、 To prevent human injury, please verify whether the screws and the nuts are loose, whether they have unexpected contact with other components after finish operating.
- 4、 To prevent human injury, when it has to operate with the power on, please be careful enough and do not press the button accidentally.
- 5、 To prevent human injury and being involved in the machine, please be careful enough and do not let your hair or clothes touch the transmission part when operating sewing test.

### Disassemble, Assemble

1. To prevent human injury, please make adjustments within the range indicated in this Service Manual and the Operation Manual.
2. To prevent human injury, please operate after the machine has been installed steadily.
3. To prevent human injury, please verify whether there is unexpected contact between components after finishing assemble.
4. To prevent human injury, when solidifying the screw and the nut, if there is specified torsional moment, please solidify in coincidence with the requirement; if there is no such requirement, please solidify in an appropriate torsional moment.
5. To prevent human injury, please verify whether the direction of rotation is correct during trial running.
6. To prevent human injury during trial running, please be careful enough and do not let your hair or clothes touch the transmission part.

 **Caution**

**Move**

1. To prevent human injury, please use two or more than two persons to lift this machine and use a moped to move it.
2. To prevent human injury, please adopt sufficient safety precautions to prevent accidental drop and turnover when lifting or moving.
3. We have made a thorough explanation about the installation in the Operation Manual, please read carefully and understand fully before operating.

**Component Replacement**

1. To prevent accidents and electric shock, please authorize the technicians with electrical knowledge to operate.
2. To prevent the accidents and electric shock, when it is necessary to open the electrical cabinet, please cut off the power first and then open the electrical cabinet after at least 5 minutes. Do not operate when your hands are wet.
3. To prevent human injury, please replace the components under the directions in this Service Manual and the Operation Manual.
4. To prevent human injury, please operate after the machine has been installed steadily. Meanwhile, it is necessary to choose appropriate tools.
5. To prevent human injury, please verify whether this component has unexpected contact with other components after replacing and verify whether the connecting terminal and the plug are poor contact, whether the screws and nuts are loose.
6. To prevent human injury, please verify whether the connecting terminal, cable head are damaged, shed or loose after operating.

According to the request of security, there are some floating polyvinyl chloride tube, insulating tape and other insulating materials, and the internal wiring adopt the circuitous way in order to keep away from the high-tension line. And all of them should be reprimed after operating.

7. Please use the genuine components made by our company to replace.

Our company shall not bear any responsibility for the accidents caused by the using of the components which are not made by our company.

If you couldn't replace the components normally under the direction, please stop repairing and contact with the technicians in our company or in the agency shop.

8. To prevent human injury, if the fuse blows out, please cut off the power, find out the cause, eliminate the trouble, and then replace a new fuse with the same capacity (specification).



## Adjustmen



1. To prevent accidents and electric shock, please authorize the technicians with electrical knowledge to operate.
2. To prevent the accidents and electric shock, when it is necessary to open the electrical cabinet, please cut off the power first and then open the electrical cabinet after at least 5 minutes. Do not operate when your hands are wet.
3. To prevent human injury, please make adjustments on the adjustable components (variable inductance, potentiometer, variable capacity) according to the indications in this Service Manual and the Operation Manual only
4. To prevent human injury, please operate after the machine has been installed steadily. Meanwhile, it is necessary to choose appropriate tools.
5. To prevent human injury, please verify whether the screws and the nuts are loose, whether they have unexpected contact with other components.
6. To prevent human injury, please verify whether the connecting terminal, cable head are damaged, shed or loose after operating.
7. To prevent human from injury and being involved in the machine, please be careful enough and do not let your hair or clothes touch the transmission part when operating sewing test.

## Disassemble, Assemble

1. To prevent human injury, please make adjustments within the range indicated in this Service Manual and the Operation Manual.
  2. To prevent the accidents and electric shock, when it is necessary to open the electrical cabinet, please cut off the power first and then open the electrical cabinet after at least 5 minutes. Do not operate when your hands are wet.
  3. To prevent human injury, please replace the components under the directions in this Service Manual and the Operation Manual.
  4. To prevent human from injury, please operate after the machine has been installed steadily. Meanwhile, it is necessary to choose appropriate tools.
  5. To prevent human injury, when solidifying the screw and the nut, if there is specified torsional moment, please solidify in coincidence with the requirement; if there is no such requirement, please solidify in an appropriate torsional moment.
  6. To prevent human injury, please verify whether the screws and nuts are loose, whether they have unexpected contact with other components.
  7. To prevent human injury, please verify whether the connecting terminal, cable head are damaged, shed or loose after operating.
- According to the request of security, there are some floating polyvinyl chloride tube, insulating tape and other insulating materials, and the internal wiring adopt the circuitous way in order to keep away from the high-tension line. And all of them should be repristinated after operating.

8. To prevent human injury, please verify whether the direction of rotation is correct during trial running.
9. To prevent human from injury during trial running, please be careful enough and do not let your hair or clothes touch the transmission part.

### Important Safety Instructions about WS-8700

 <p><b>Danger</b></p>	<ol style="list-style-type: none"> <li>1. To prevent electric shock, during the power supply importing period, do not touch the components in the electrical cabinet when the motor electrical cabinet is open.</li> <li>2. After changing pattern, please verify the needle point. Once the pattern exceeds the presser foot, the needle would run into the presser foot and snap.</li> </ol>
 <p><b>Caution</b></p>	<ol style="list-style-type: none"> <li>1. When power is on, but no display on the operation screen, please cut off the power and verify the supply voltage and the power source specification.</li> <li>2. To prevent the accident caused by the accidental start, before pressing the start button please verify there is no barriers underneath when coiling.</li> <li>3. When the power button is off, the setout button is on, and the presser foot button is on, do not put your fingers beneath the presser foot, because the presser foot will automatically fall down.</li> </ol>

## Safety Device

The machineries and safety devices recorded here are made under the domestic specifications; the devices may be different according to different sale places and different specifications.





## Danger

The book, in some places have been omitted the eye shield, therefore pre-informed you that, in actual use, you should never remove the safety device!

---

# Contents

One. Specification .....	1
Two. Names of panel and notes .....	错误!未定义书签。
Three. Operation and function .....	3
<u>1、 Start-up screen .....</u>	<u>3</u>
<u>2、 Operation and instructions on main interface.....</u>	<u>3</u>
<u>3、 Monitor Screen.....</u>	<u>5</u>
<u>4、 Parameter Screen .....</u>	<u>7</u>
<u>5、 Patten selection screen.....</u>	<u>7</u>
<u>6、 Gallery interface .....</u>	<u>9</u>
<u>7、 Alarming record screen.....</u>	<u>11</u>
<u>8、 Manual operation screen.....</u>	<u>11</u>
<u>9、 Calibration interface .....</u>	<u>13</u>
<u>10、 Advanced setting interface .....</u>	<u>14</u>
<u>11、 Input-output interface .....</u>	<u>16</u>
Four. List of Failure Information .....	18
Five. Electrical Schematic Diagram .....	22

---

# One. Specification

## 1、Basic Parameter

Ordinal	Project	Basic parameters
1	Maximum sewing speed (needle/min)	3000
2	Stitch length/mm	1-3
3	Cloth feeding mode	Servo cloth feeding in X/Y direction
4	Sewing scope/mm	220
5	Rated voltage/V	Arbitrarily set; total length≤655
6	Operating air pressure/Mpa	0.5
7	Air consumption/L/min	200
8	Dimension mm	1700L×1500W×1450H
9	Weight	400Kg

※ Maximum sewing speed can be used according to the drop speed of the sewing condition.

## Two. Name of Operation Panel and Notes



	Button/Display	Content
①	Reset Button	Servo returns to zero point and the machine enters into work state after this button being pressed.
②	Power ON	Main supply of the machine is on after this button being pressed.
③	Power OFF	Main supply of the machine is off after this button being pressed.
④	EM	The system will stop after emergency button being pressed, thereafter, press button ① for system restoration when emergency button is canceled.
⑤	Human-machine Interface	Set sewing parameter and select machining graphics on human-machine interface.

---

## Three. Operation and Function

### 1. Start-up screen



Figure (I) start-up screen

When the boot initialization is finished, the system will automatically enter the main screen, as shown in figure (two). Please do not operate the machine during this time, because the system is not ready state.

### 2. Operation and instructions on main interface



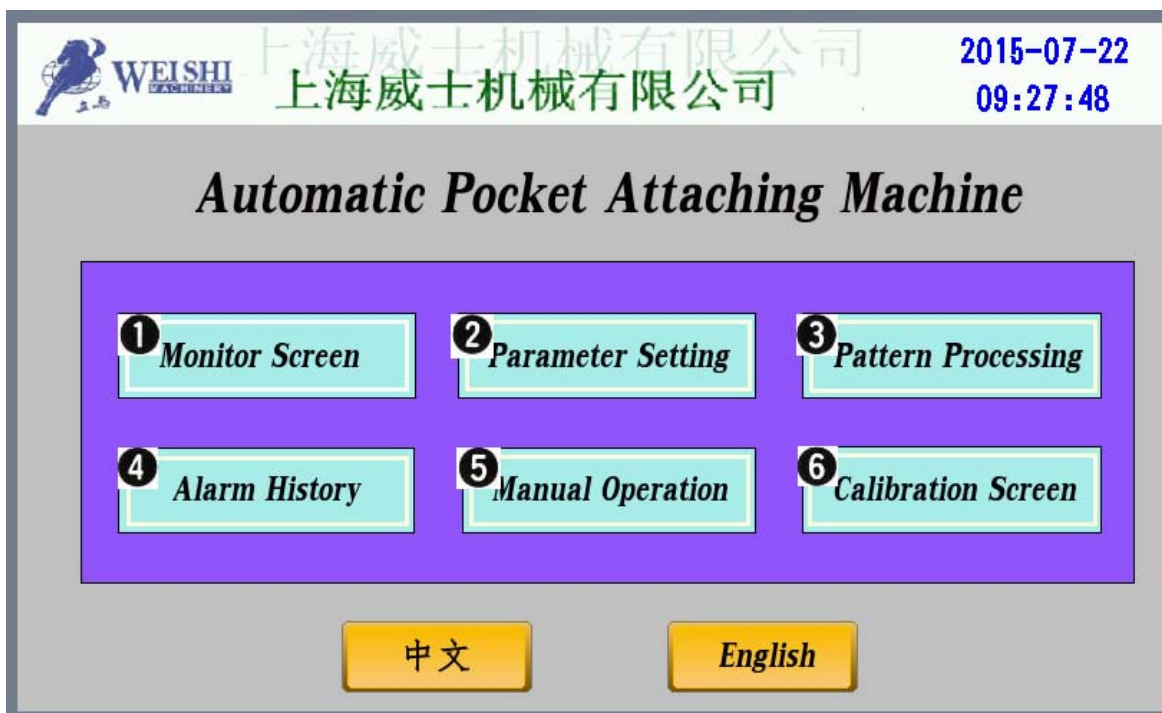

Figure (II) system main interface

	Button/Display	Content
<b>1</b>	Monitor screen	Press the button, the servo reverting machine enters working state.
<b>2</b>	Parameter Setting	Pressing the relevant button can carry out the operation of sewing set, parameter set, manual operation, sewing test, system test and alarm list respectively.
<b>3</b>	Pattern processing	Click this button to enter the graphics processing, to choose the wanted file and modify the stitch length. (with a security level 1 of the picture)
<b>4</b>	Alarm History	Press the button to find the recent alarm records.
<b>5</b>	Manual Operation	Press the button to enter manual screen, each axis can be pointed operated and tested on its condition. (with a security level 1 of the picture)
<b>6</b>	Calibration Screen	Press the calibration screen button to set the location of starting , martial , ending sewing and etc. (with a security level 1 of the picture). Non-professionals please do not to get into and modify parameters, otherwise the consequences.

### 3. Monitor Screen



Figure (III) Monitor Screen interface

Pleasure reset the system before operating the screen, or some parameters would be locked and not revised caused by security.

Figure (IV) system main interface

	Button/Display	Content
①	Reset state	Display the current system state.
②	Information of graphics processing	Display the current graphics processing.
③	processing needle number	Display the number of current processing needles
④	total needle number of sewing patten	Display the total needle number of current sewing patten
⑤	Stitch Forward	In the trial sewing mode and when thread breakage, press this button, the material presser will move to the next stitch position.
⑥	Stitch Back	In the trial sewing mode and when thread breakage, press this button, the material presser will move back to the former stitch position.

7	Press down the sewing foot presser	Press down the sewing foot presser to thread as it break. <b>Pay attention to lift the foot presser after threading.</b>
8	Single step/continuous processing mode	Press the button to choose single step or continuous processing mode. In single step mode, press start button to enter the next processing after the current step is over. In continuous processing mode, the system will perform all the processes.
9	Processing information	Display the current name of patten, start type, stitch length, strengthening needle number, sewing speed, getting material speed.
10	Output count and zero clearing	Display the current cumulative value, press zero clearing to count zero.
11	Back button	Press this button to sign out and return to system main interface

#### 4. Parameter Screen



Press **Parameter Setting** button on the system main screen **【picture (II)】**, the system will switch to the screen as picture(V).

Figure (V) Parameter interface

	Button/Display	Content
①	pocket folding delay setting	Set the delay time of cylinder action to get the step of folding bag.
②	Bottom Counter Setting	Setting the alarm of counting bottom shuttle, the system can compare the current counting with setting value. press zero clearing to count zero.
③	Speed of sewing	Set the current speed of sewing.
④	Speed of getting material	Set the current speed of getting material.
⑤	Zigzag Sewing Speed	Setting the zigzag sewing speed.
⑥	Thread breakage Detection ON/OFF	Select whether to start the function of thread break or not.
⑦	Stacker ON/OFF	Select whether to start the function of receiving material or not.
⑧	Bobbin Counter ON/OFF	Select whether to start the function of counting bottom shuttle.
⑨	Vacuum motor ON/OFF	Select whether to start the function of vacuum motor.
⑩	Grid Check ON/OFF	Select whether to start the function of matching plaid.
⑪	Overlap Folder ON/OFF	Select whether to use the overlap folder cylinder.
⑫	Move out/continue when thread breakage	If you choose move out when thread breakage takes place, the machine will stop sewing, and move out to the waiting position, if you choose continue when thread breakage takes place, the machine will stop sewing, after you lead the thread, you can press the start button to continue.
⑬	Bottom Mould ON/OFF	Select whetherto use the bottom mould frame fuction.
⑭	Back button	Press this button to sign out and return to system main interface

## 5.Patten selection screen

Press **Pattern Processing** button on the system main screen【picture (II)】,the system will request passport input.Enter the correct password, then press the OK button to switch the screen as picture(VI).



Figure (VI) Patten selection screen

	Button/Display	Content
①	Display area of graphics processing	Display the current graphics processing
②	Read Status	Displaywether the reading file is over.
③	Mould selection	Select the processing graphics and set the number of strengthening needles.
④	From file	Select the route of the graphics processing file,which read from files and gallery.The system read the file from memory card.The storage name of graphics in CAD should be correct beforehand, or the it can't be read out.For reading from gallery, you should establish a graphical model in the gallery before.
⑤	Read file button	Press this button to read the current processing after selecting the right file.
⑥	Stitch length	Set the stitch length within the rang of 1-3mm.

7	Modify button of stitch length	Press this button to modify the current stitch length to the set value
8	Graphics editor button	Press this button to enter gallery and editor the graphics.
9	Back button	Press this button to sign out and return to system main interface

## 6. Gallery interface

Press  button on Patten selection screen **【picture (IV)】** to enter Gallery screen as picture(VI).

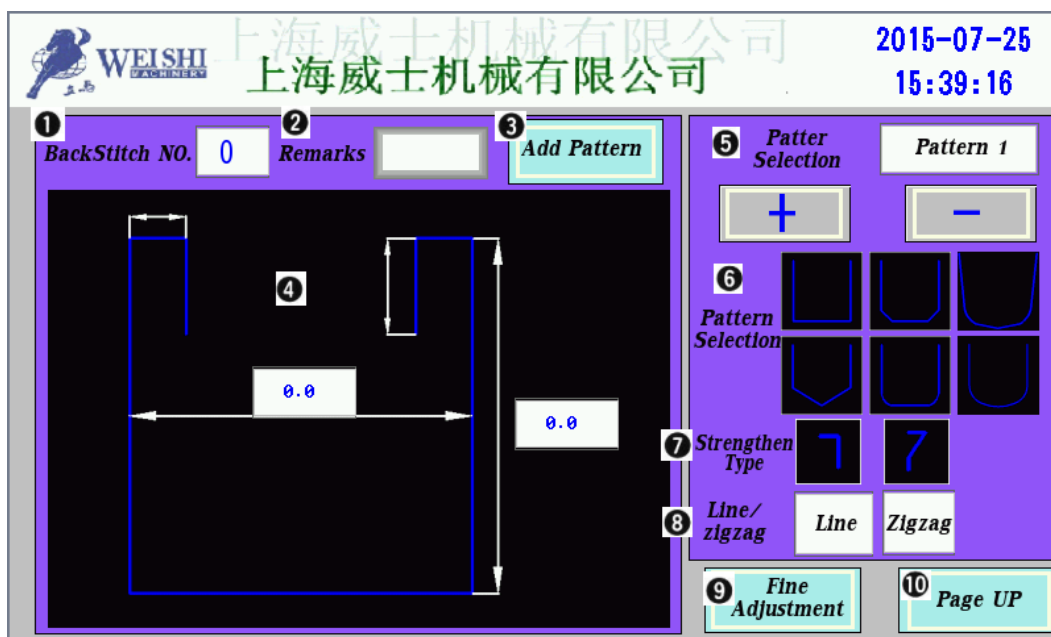
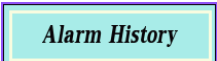

Figure (VII) Gallery interface

	Button/Display	Content
1	Strengthening needles	Setting the number of strengthening needles of the current processing file.
2	Remarks	Remark the current processing file for distinction ,which can be set up to two digits or letters
3	Graphics add	Press the button to generate processing graphics after setting all parameters.
4	Edit area of graphics	Set the width, depth, strengthening width, strengthening depth of the current graphics in this area.
5	No.of edit graphics	Select the No.of edit graphics.If the edit existing number, <b>pls pay attention to the new file will recover the old one.</b>

6	Graphics selection	There are 3 graphics in gallery for selection.
7	Strengthening types	There are 2 strengthening types for selection.
8	Line/Zigzag Mode selection	Select the line mode or zigzag mode.
9	Graphics fine-tuning	Enter the screen and cautiously set the datas . <b>Pls pay attention to enter the calibration interface for mold matching after setting datas everytime, to avoid needles stick into the mould by the mistake of data.</b>
10	Back button	Press this button to sign out and return to previous interface

## 7. Alarming record screen

Press  button on the system main screen【picture (II)】,the system will switch to alarming record screen as picture(VIII).The current alarming history can be found in this interface.

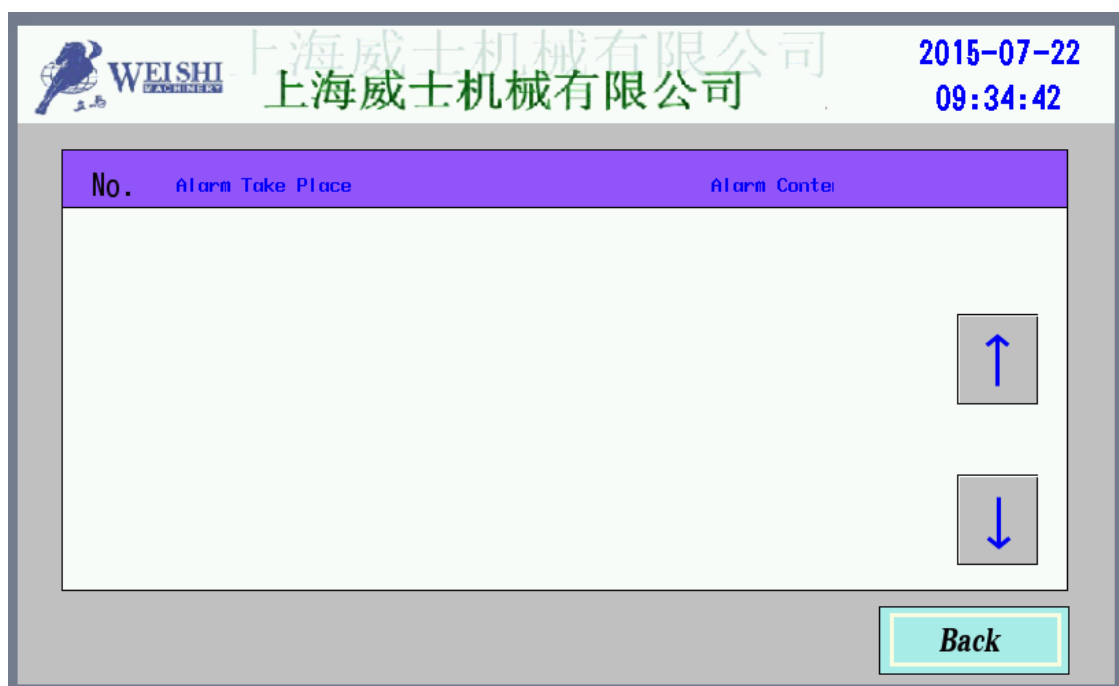

Figure (VIII) Alarming record screen

## 8.Manual operation screen

Press **Manual Operation** button on the system main screen 【picture (II)】, the system will switch to manual operation screen as picture(XI).Pls press reset button before enter this screen ,and then operation can be carried out.Pls pay attention to avoid collision during operation.

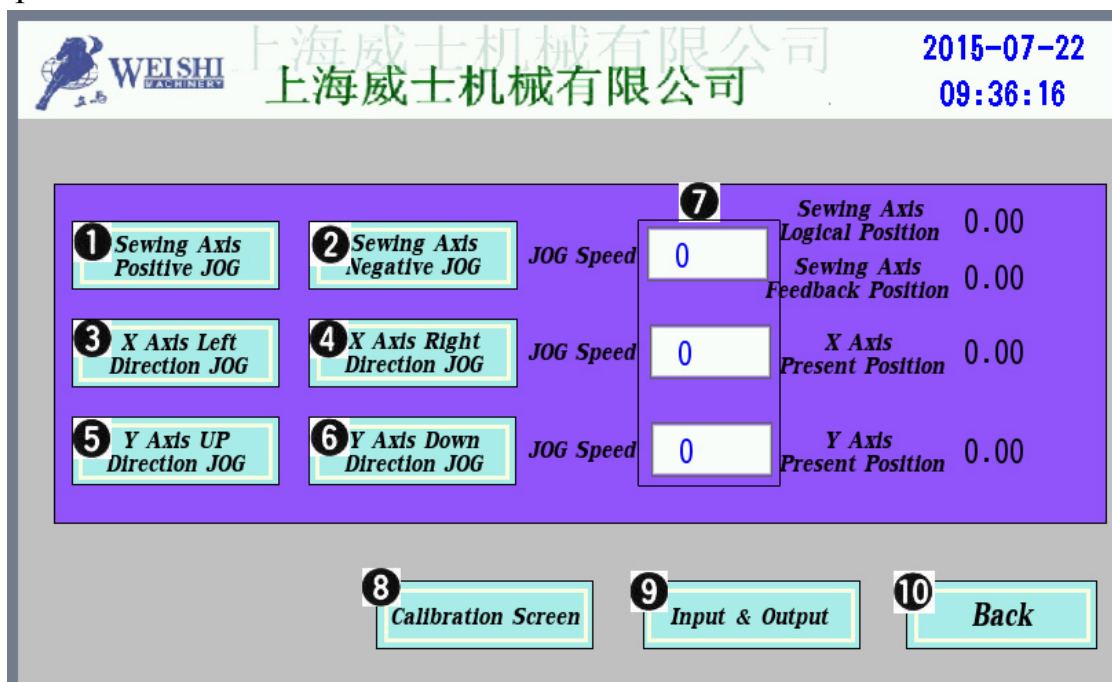

Figure (IX) manual operation screen

	Button/Display	Content
①	Needle bar forward pointed	Press this button to set the speed of counterclockwise rotation.If the speed is set to zero, it will not rotate.
②	Needle bar negative pointed	Press this button to set the speed of clockwise rotation.If the speed is set to zero, it will not rotate.
③	X-axis left pointed	Press this button to adjust the left-right position of the motor at the left moving speed set. If the speed is set to zero, it will not rotate.
④	X-axis right pointed	Press this button to adjust the left-right position of the motor at the right moving speed set. If the speed is set to zero, it will not rotate.
⑤	Y-axis left pointed	Press this button to adjust the forward-backward position of the motor at the forward moving speed set. If the speed is set to zero, it will not rotate.
⑥	Y-axis right pointed	Press this button to adjust the forward-backward position of the motor at the backward moving speed set. If the speed is set to zero, it will not rotate.



7	Setting area of pointed speed	Set the pointed speed of axis in all direction.
8	Calibration interface	Press this button to enter calibration screen. <b>Pls pay attention to set the parameters cautiously after enter the calibration interface.</b>
9	Input-output interface	Press this button to enter input-output interfac , <b>Monitor signal, test every signal during repairing.</b>
10	Back button	Press this button to sign out and return to main interface.

## 9. Calibration interface

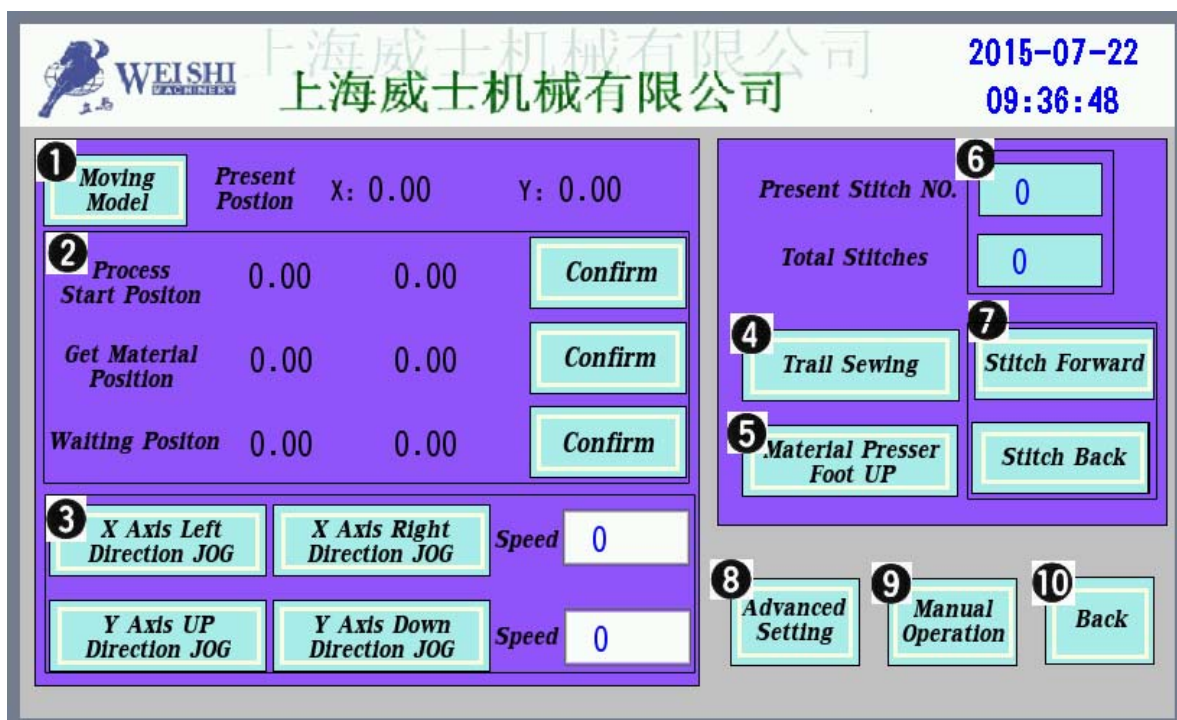



Press  button on the system manual operation screen 【picture (IX)】, the system will switch to calibration interface as picture(X).

Figure (X) Calibration interface

	Button/Display	Content
1	Move mode / input mode	Select the origin of data. At move mode, move to the position by manual, then press OK button; At input mode, type the data by manual, then press OK button.
2	Coordinate display area	Display the information of current coordinate.
3	X, Y axis	Pls set the speed first. Press the corresponding button to control the moving on the axis.

④	Trajectory calibration	Press this button to enter the mode of trajectory calibration. The presser automatically presses down and moves to the start position. <b>Pay attention to reset before press the button.</b>
⑤	Presser lifting	Press this button to control the presser moving up and down. <b>Pay attention that the presser can break the needle in unsafe working area. Pls operate with caution.</b>
⑥	Needle number	Display the amount and number of current processing needles.
⑦	Previous stitch/next stitch	Enter the trajectory calibration for mold matching by press the previous stitch/next stitch, to ensure the needle is in middle of mould. If it is not in the middle, pls readjust the start position of machining graphics and press reset button after mould marching.
⑧	Advanced setting	Press this button to enter advanced setting surface.
⑨	Manual operation	Press this button to return to manual operation surface.
⑩	Back button	Press this button to sign out and return to main interface.

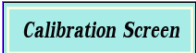
## 10. Advanced setting interface

Press  button on Calibration Screen **【picture (X)】**, the system will switch to advanced setting interface as picture (XI).

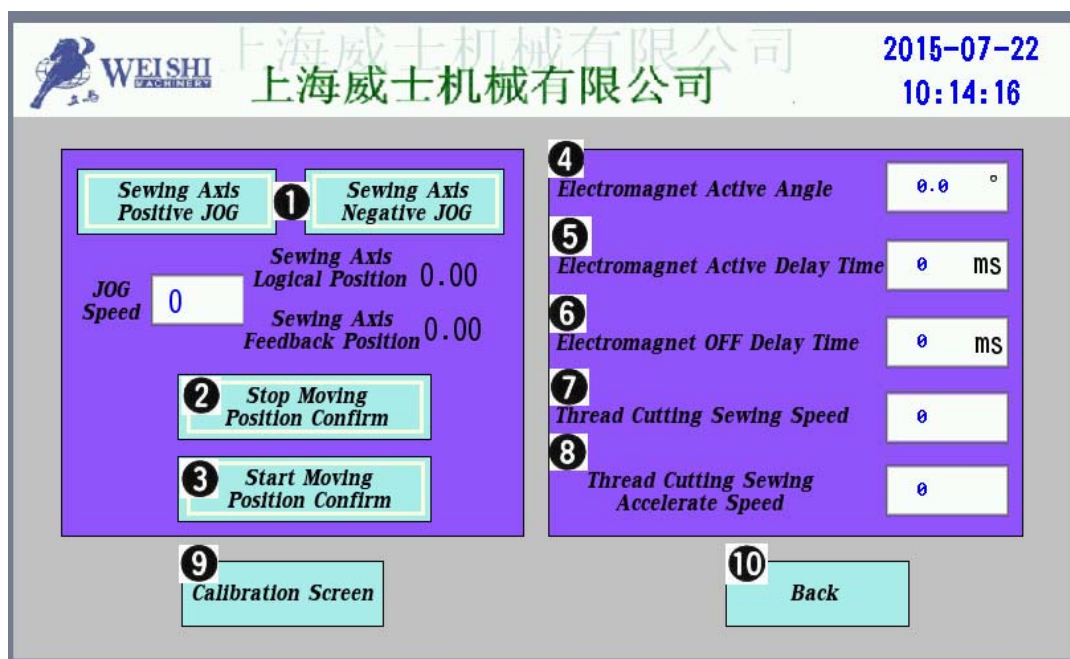



Figure ( XI ) Advanced setting interface

Pls reset before enter this interface.

	Button/Display	Content
①	Positive / negative needle bar pointed	Press this button to control the positive and negative rotate, the speed is set in the blank of needle bar speed.If the speed is zero, it will not rotate.
②	Confirming falling position of needle bar	Press positive needle bar pointed button to move the needle bar to the position of needle hole, and then press this button to make the system keep record of the falling position of needle bar.
③	Confirming lifting position of needle bar	Press negative needle bar pointed button to move the needle bar to the position of needle hole, and then press this button to make the system keep record of the lifting position of needle bar.
④	Angle of electromagnet connection	Set the angle of electromagnet connection for cutting thread.
⑤	Delay time of electromagnet connection	Set the delay time of electromagnet connection.
⑥	Delay time of electromagnet disconnection	Set the delay time of electromagnet disconnection.
⑦	Velocity of lifting needle bar when trimming	Set the velocity of lifting needle bar when trimming
⑧	Acceleration of lifting needle bar when trimming	Set the acceleration of lifting needle bar when trimming
⑨	Calibration interface	Press this button to return to calibration interface, which requires a password to enter.
⑩	Back button	Press this button to sign out and return to main interface.

Press  button on main interface. The system will pop up a window for entering the password, you must enter the correct password, otherwise unable to enter the calibration interface, the operation refers to calibration screen.

## 11. Input-output interface

Press  button on Manual operation screen, the system will switch to Input interface as picture(XII).

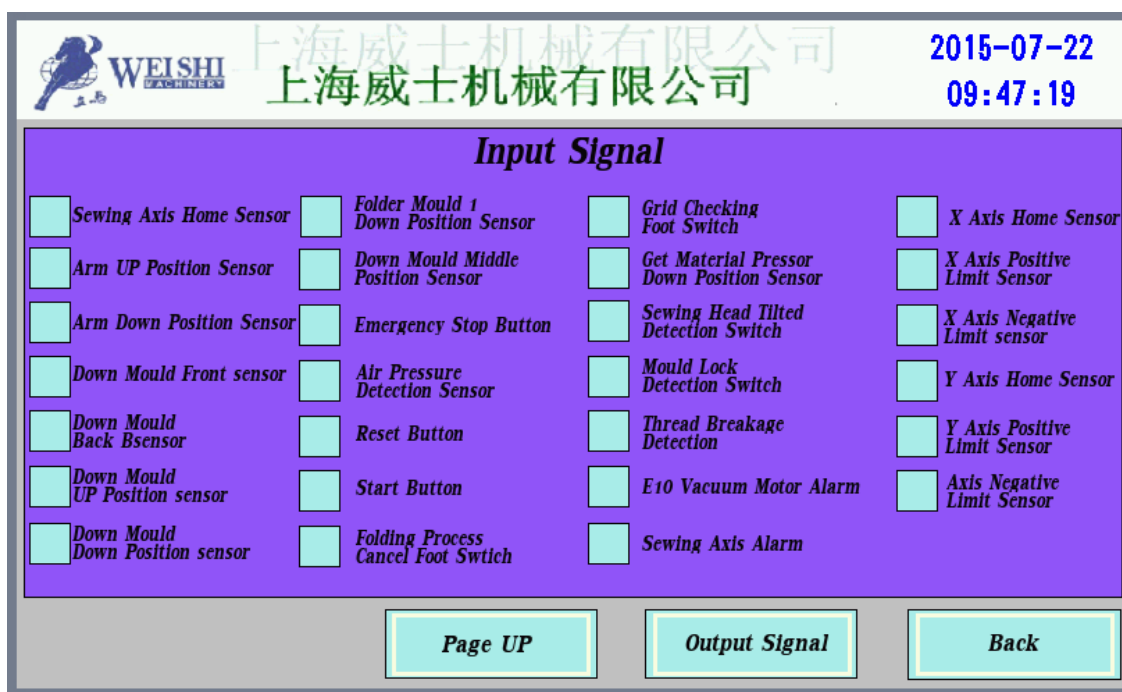



Figure (XII) input-output interface

On input interface you can monitor all input signals. When the input signal is ON, the corresponding grid will turn red. The interface can present testing signals for maintenance.

Press  button on input interface, the system will switch to output signal testing interface as picture(XIII). Please reset before entering.

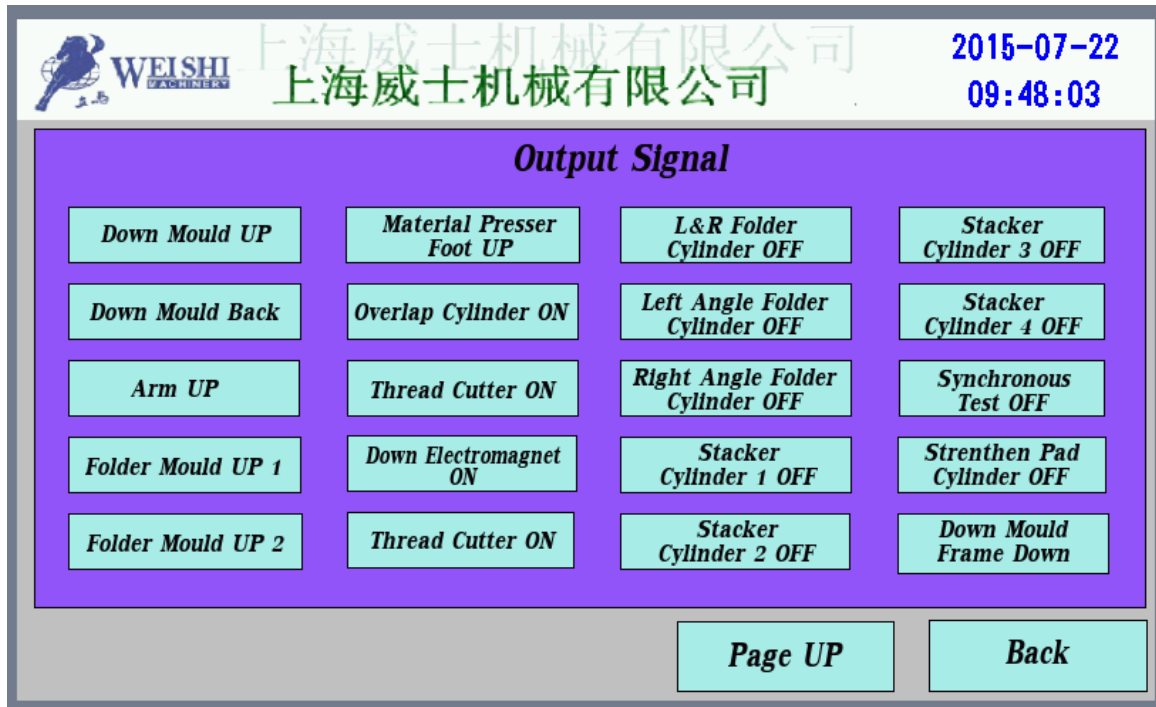

Figure (XII) output signal testing interface

Pls reset after operation completed, otherwise the machine does not respond when pressing the start button.

## Four. List of Fault Information

No.	Fault Information	Processing method
E01	E01 Needle bar alarm	When PLC detect the drive alarming of needle bar, the enter point of corresponding signal is I2B4.Please check whether the drive of needle bar alarm. Solution:Turn off the power when alarming, and wait for 15s to restart the power,then press reset button to put the machine into preparing state.
E02	E02 X-axis alarm	When PLC detect the drive alarming of X-axis, please check whether the drive of needle bar alarm. Solution:Turn off the power when alarming, and wait for 15s to restart the power,then press reset button to put the machine into preparing state.
E03	E03 Y-axis alarm	When PLC detect the drive alarming of Y-axis, please check whether the drive of needle bar alarm. Solution:Turn off the power when alarming, and wait for 15s to restart the power,then press reset button to put the machine into preparing state.
E04	E04 Emergency stop	When alarming, please check whether emergency stop button is pressed or loosen.The enter point of corresponding signal is I1B2, and it is “ON” when the emergency stop is not pressed. Solution:Unlock the emergency stop, press reset button to reset the alarm.Then press it again, the machine gets into preparing state.
E05	E05 Insufficient ground thread	When start the function of bobbin counter, the stitching number is accumulated.Until it reaches the setting value, the system will alarm to remind the operator to replace bobbin.The operator can't start the machine before alarming. Solution:Replace the bobbin, press button of bobbin counter to clear zero, then press reset button to put the machine into preparing state.
E06	E06 Tread breakage alarm	Starting tread breakage detection , the system will hint information when detect breakage signal within the allotted time, and stop the sewing to exit to the waiting position.The corresponding signal is I2B2. Solution: Thread and press reset button, machine will enter to preparing process state.
E07		The system is equipped with machine head overset detection for the safty to avoid collision accident during maintaince.It

	E07 Machine head overset detection	signals when detecting overset.,the corresponding signal is I2A8 Solution: If the machine head overset ,please place in the normal position.If machine head overset without alarming,please check the signal switch to see if it's broken.
EO8	E08 Pressure alarm	The system is equipped with pressure detection for the influence on the safety operation.It will alert the pressure alarm when the pressure is lower than the set value(0.35MP), at this time the machine can not start, the corresponding signal is I1B3. Solution: Please check if the air pressure is high enough, if the pressure detection switch is normal,if I1B3 wiring is damaged.
EO9	E09 Graphics error	The system is with the function of pattern size editor and SD card transmission.In the graphics generation and processing, the system will promot error when detecting the size or CAD faults.Please re edit.
E10	E10 Vacuum pump alarm	The plate is with the function of vacuum.The fun of vacuum pump is 380V/3. The system is with thermal relay protection which will automaticly disconnect when detecting abnormalcurrent and voltage, the corresponding signal is I2B3. Solution:(1)Please turn off the electricity to test the balance of phase resistance.(2)Please check if the motor gets too much hot.(3)Please check if the thermal relay is damaged or the protecting current is too small (93.9A) .
E11	E11 Mold unlocked	The system is with the function of detecting mold locked, for the safty to avoid collection accident. The corresponding signal is I2B1 and present "ON" when the mold locked. Solution:(1)Please check if the switch tuned to locked.(2)Please check if the switch is damaged.(3)Please check if the signal I2B1 is connected.
E12	E12 Communication network alarm	The system is adoped EtherCat to alert when detecting fault. Solution:(1)Please check the communication network connection from touch screen to PLC. (2) Please check the cable connection from PLC to drive in X axis and Y axis. Turn off the power when alarming, and wait for 15s to restart the power.If it still doesn't work, please contact the equipment developer.
E13	E13 Motion control alarm	The system is with the detection the motion control alarm. Solution: Turn off the power when alarming, and wait for 15s to restart the power. If it still doesn't work, please contact the equipment developer.
E14		PLC can detection the faults.

	E14 PLC alarm	Solution:(1)Please PLC alarm.(2)Please check if the emergency button is pressed.(3)Please check the air pressure. If it still alarms exclude the above references, please turn off the power and wait for 15s to restart the power.
E15	E15 Bottom mould pressing overtime	The system doesn't detect the signal (I1A8) when pressing bottom mould at a predetermined time. Solution: (1)Please check if the signal(I1A8) is "ON" when pressing and the wire damaged.(2)Please check if the output signal (O1A6) is" ON" and the wire damaged.(3) Please check if the solenoid valve cables of O1A6 burned.
E16	E16 Bottom mould lifting overtime	The system doesn't detect the signal (I1A7) when lifting bottom mould at a predetermined time. Solution: (1)Please check if the signal(I1A7) is "ON" and the wire damaged.(2)Please check if the output signal (O1A5) is" ON" and the wire damaged.(3) Please check if the solenoid valve cables of O1A5 burned.
E18	E18 Bottom mould extending overtime	The system doesn't detect the signal (I1A6) when extending bottom mould at a predetermined time. Solution: (1)Please check if the signal(I1A6) is "ON" and the wire damaged.(2)Please check if the output signal (O1A8) is" ON" and the wire damaged.(3) Please check if the solenoid valve cables of O1A8 burned.
E19	E19 Arm pressing overtime	The system doesn't detect the signal (I1A3) when pressing arm at a predetermined time. Solution: (1)Please check if the signal(I1A3) is "ON" and the wire damaged.(2)Please check if the output signal (O1A2) is"ON" and the wire damaged.(3) Please check if the solenoid valve cables of O1A2 burned.
E20	E20 Arm lifting overtime	The system doesn't detect the signal (I1A2) when lifting arm at a predetermined time. Solution: (1)Please check if the signal(I1A2) is "ON" and the wire damaged.(2)Please check if the output signal (O1A1) is"ON" and the wire damaged.(3) Please check if the solenoid valve cables of O1A1 burned.
E21	E21 Edgefold 1 pressing overtime	The system doesn't detect the signal (I1B1) when pressing edgefold at a predetermined time. Solution: (1)Please check if the signal(I1B1) is "ON" and the wire damaged.(2)Please check if the output signal (O1B1) is"ON" and the wire damaged.(3) Please check if the solenoid valve cables of O1B1 burned.
E22	E22 Plant pressing overtime	The system doesn't detect the signal (I2A6) when pressing the plant at a predetermined time.



		Solution: (1)Please check if the signal(I2A6) is “ON” and the wire damaged.(2)Please check if the output signal (O1A4) is”ON” and the wire damaged.(3) Please check if the solenoid valve cables of O1A4 burned.
E23	E23 Overtime of needle bar returning to the origin	The system alerts and terminates the step when the needle bar returns to the origin beyond a predetermined time.Please check the original signal, which is I1A1.
E24	E24 Restoration overtime	The system alerts and cancels the step if the restoration is beyond a predetermined time. Please check the original signal of every axis.
E25	E25 Excessive deviation of encoder	The system alerts and terminates the step if the current value of encoder is out of the safe area.Please check the return signal of encoder on the needle bar axis and if the wires are damaged.

# Five. Electrical Schematic Diagrams

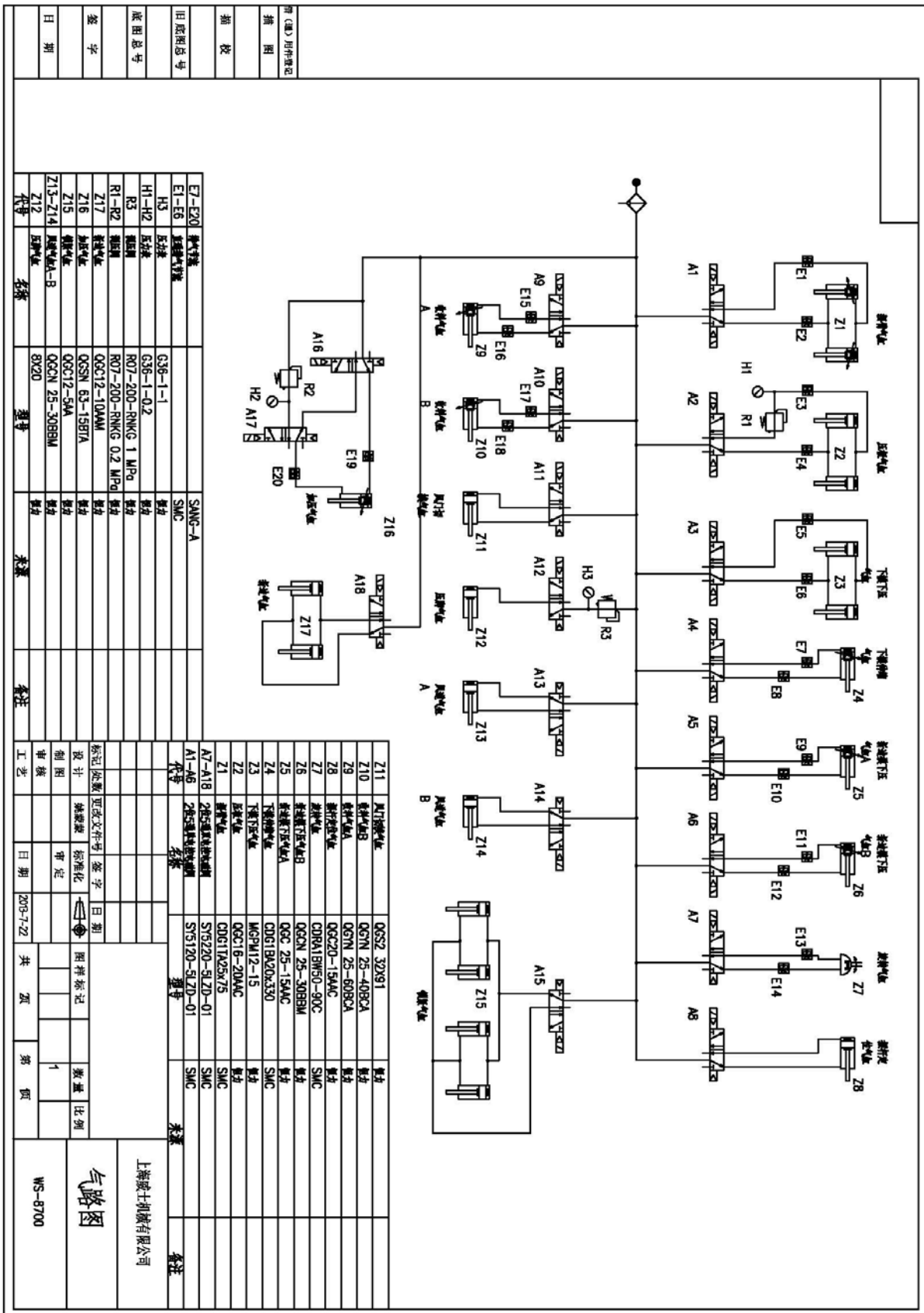

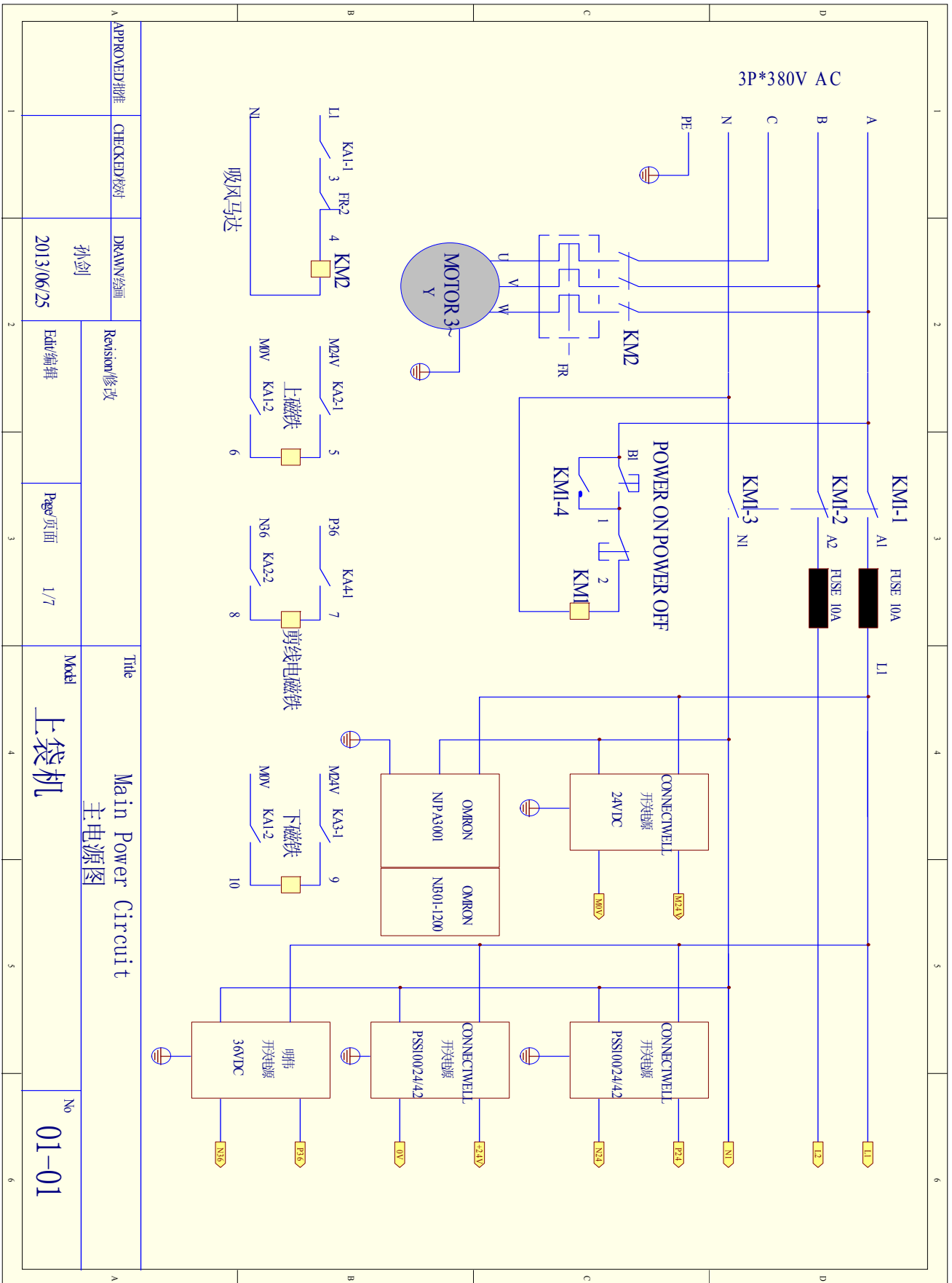

APPROVED/批准	CHECKED/校对	DRAWN/绘图	Revision/修改	Title	No
		孙剑	2013/06/25	2013/06/25	01-01
			Editor/编辑	Page/页面	
				1/7	
				Model	
				上袋机	
				Main Power Circuit	
				主电源图	

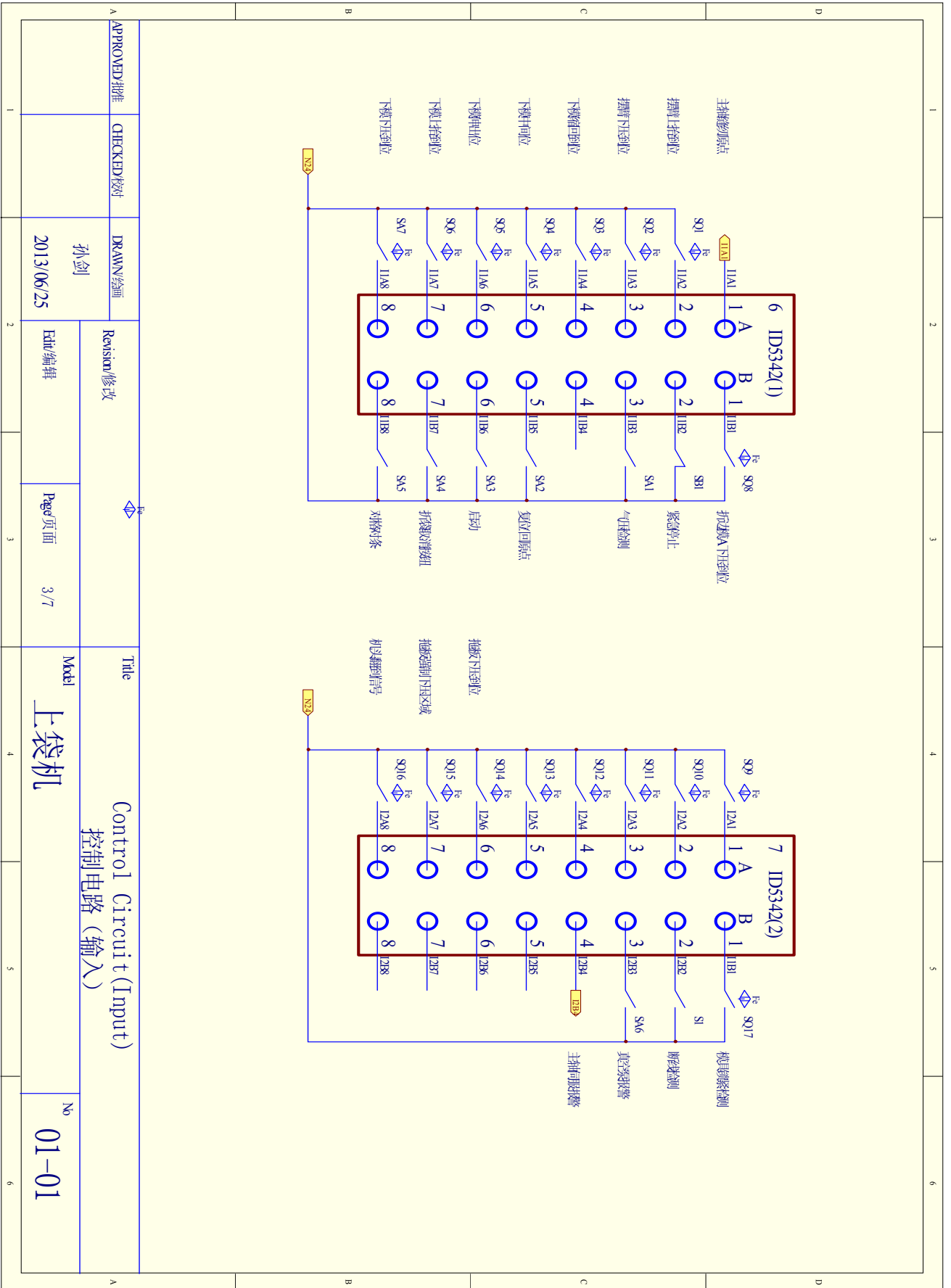

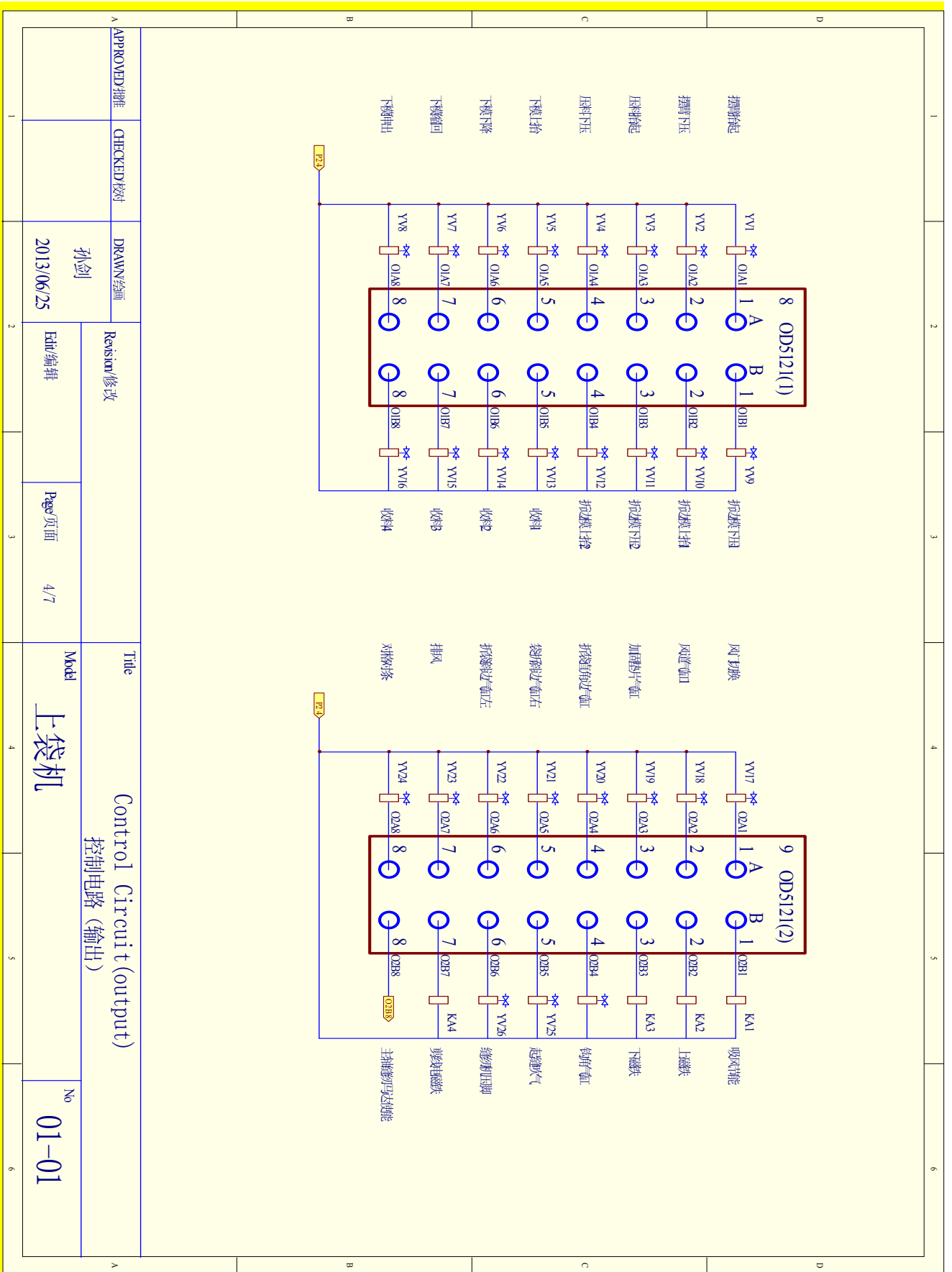

APPROVED/批准	CHECKED/校对	DRAWN/绘图	Revision/修改		Title	Model		No
		孙剑	2013/06/25		Control Circuit (output)	上袋机		01-01
			Editor/编辑	Page/页面				
				4/7				

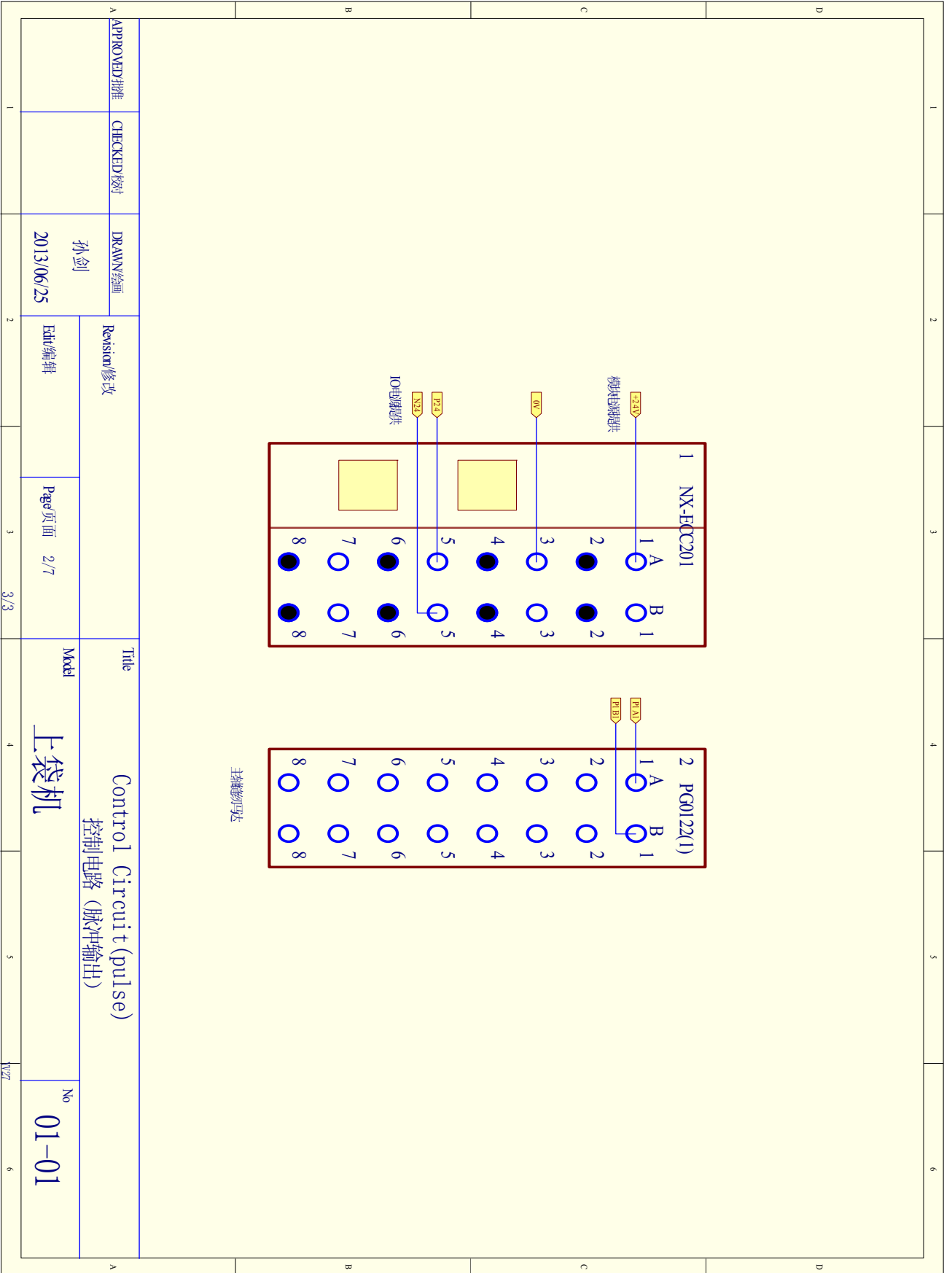

APPROVED/批准	CHECKED/校对	DRAWN/绘图 孙剑 2013/06/25	Revision/修改 Edit/编辑	Page/页面 5/7	Model 上袋机
				Title Control Circuit (module)	No 01-01

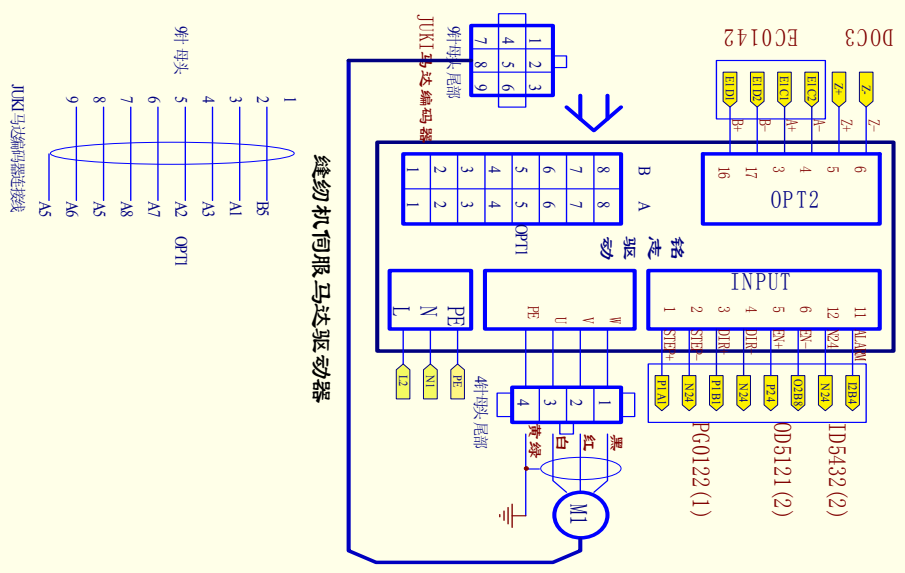
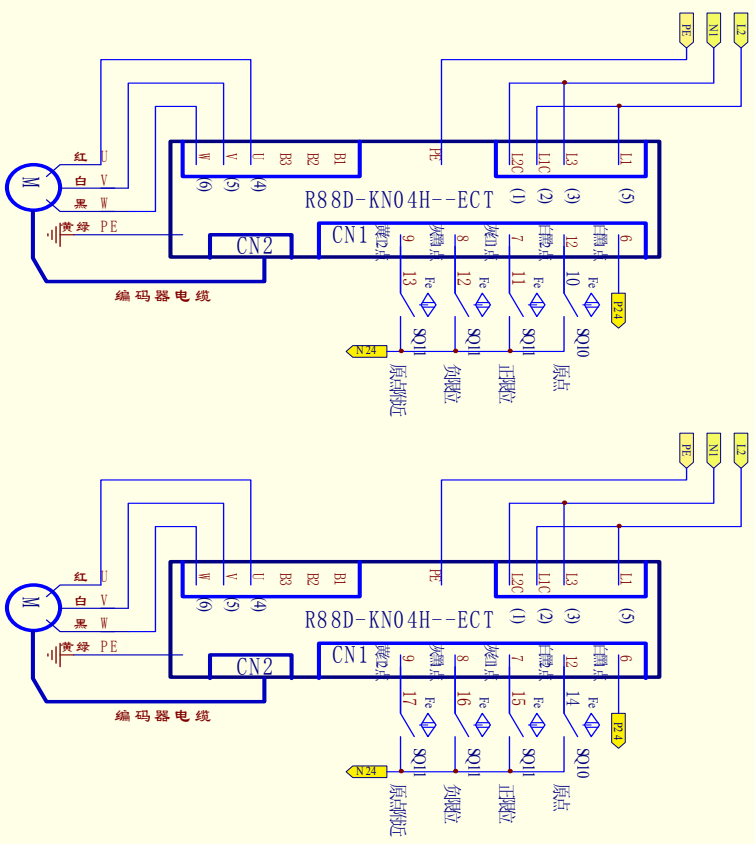

APPROVED/批准	CHECKED/校对	DRAWN/绘图	Revision/修改	Title	No
		孙剑	2013/06/25	Control Circuit (servo) 控制电路 (伺服)	01-01
			Edt/编辑	Model	
			Page/页面	上袋机	
			6/7		

Control Circuit (servo)  
控制电路 (伺服)

上袋机

No  
01-01





**Shanghai Weishi Machinery CO**

52#, No. 1089, North Qinzhou Road, Shanghai

Tel: 021-64953003

Fax: 021-64957015

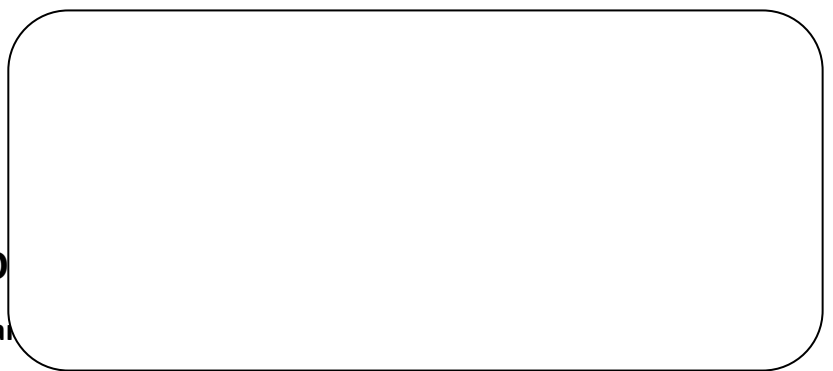

※slight differences from the picture may be possible  
due to improvements of model and appearance