

使用说明书
零件样本
INSTRUCTION MANUAL
PARTS BOOK

超高速包缝机

Super High-speed Overlock Sewing Machine

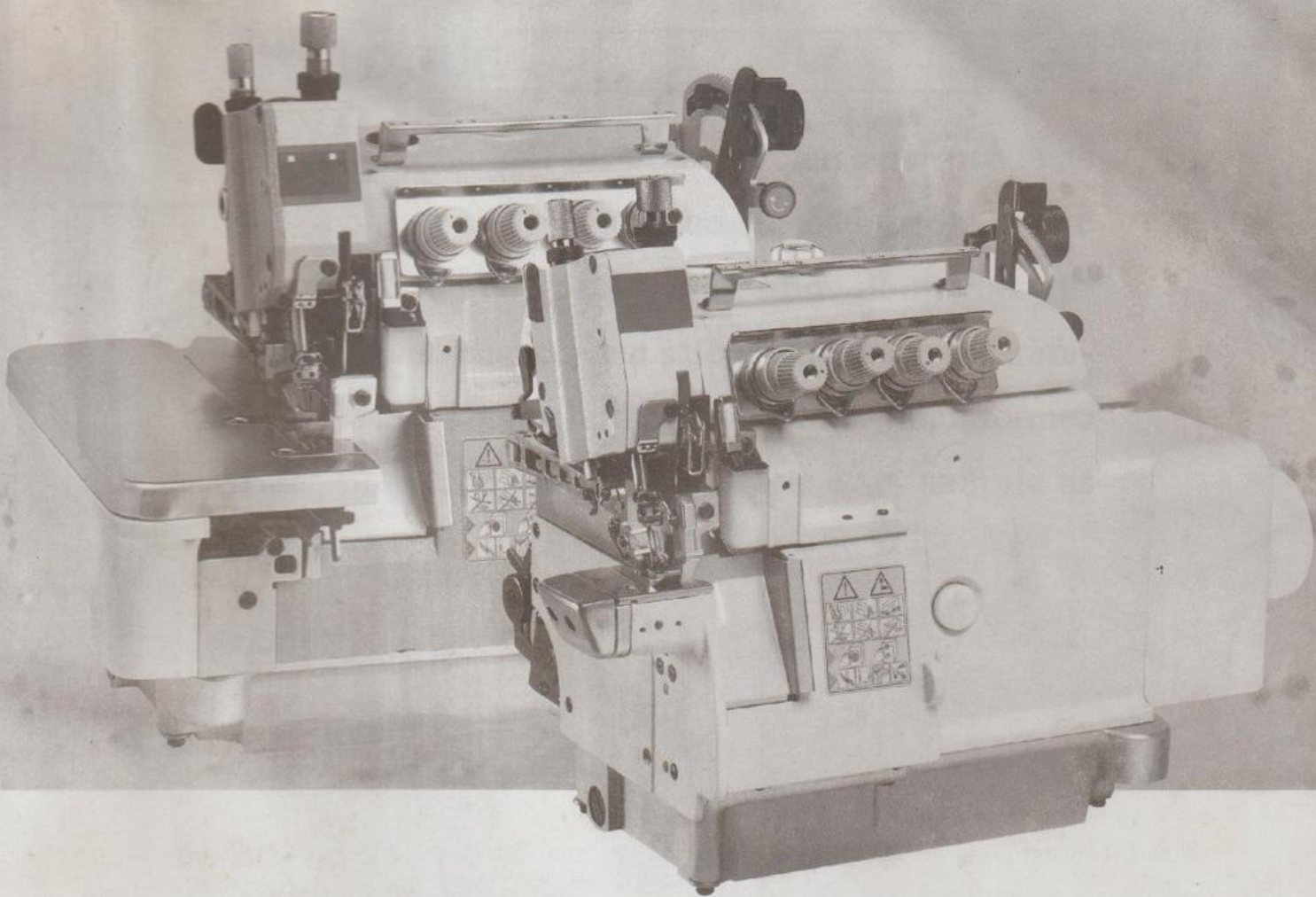

开头语

衷心感谢您购买本公司产品！使用缝纫机之前，请认真阅读此说明书。本说明书介绍了缝纫机日常使用、维护与安全的有关注意事项。请您仔细加以保管，以便日后查阅。如产品规格或外观经过改良可能会与说明书略有不同，恕不另行通知。

PROLOGUE

Thanking you for your purchase our products sincerely, please reading the manual book before operation, the book introduce some points how to operate, maintenance, and safe. Please keep it carefully for reading in the further; you will be not informed if the file has been revised. Please set sample as standard.



为了安全

对于缝纫机本身各种装置，我们充分考虑到它的安全性。请遵照基本的操作方法，安全的进行工作。

- 拆除为保证安全所设置的装置，零件的情况下使用，是非常危险的，请绝对不要拆除后使用。
- 缝纫机在使用时，请不要在缝纫机台板上放置工具及缝纫时不必要的物品。
- 在对缝纫机进行检修、调节、清扫、穿线、换针等工作时，为防止发生事故，务必请切断电源，在确认即使踩下缝纫机踏板，缝纫机也不转动之后，再进行操作。

注意

使用离合式马达的情况下，在关掉电源①后因惯性作用会继续旋转。这时如不注意踩动缝纫机踏板②时，缝纫机会突然动作，这是很危险的。

请在关掉电源后，仍继续踩动踏板②，直至缝纫机完全停下来为止。

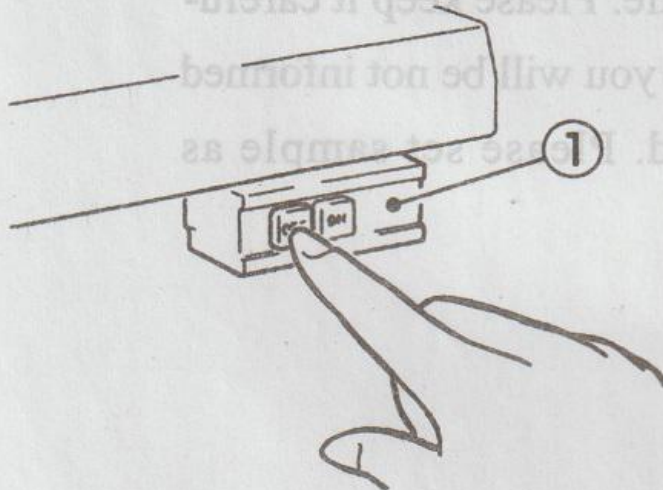

- 在离开缝纫机台时，务必请关掉电源。
- 停电时也请务必关掉电源。
- 为了总是安全地，运转良好的使用缝纫机，日常的点检是不可缺少的，请予以注意。



OBSERVE THESE SAFETY PRECAUTIONS

Though Our takes the utmost care to produce safe sewing machines and devices, operators should follow these basic safety rules.

- To prevent accidents, do not remove safety devices or parts while operating the machine.
- Do not leave tools or other unnecessary objects on the machine table while operating the machine.
- Before maintenance, adjusting, cleaning, threading or replacing the needle, and to prevent accidents, be sure the power is turned off. Check that the machine will not operate when the pedal is pressed.

Note

In case a clutch type motor is used, it will keep on rotating by inertia after turning off power supply. ① If the machine pedal ② is stepped on inadvertently, it is dangerous because the machine will move unexpectedly. Keep on stepping on the pedal ② until the machine comes to a stop after turning off power supply.

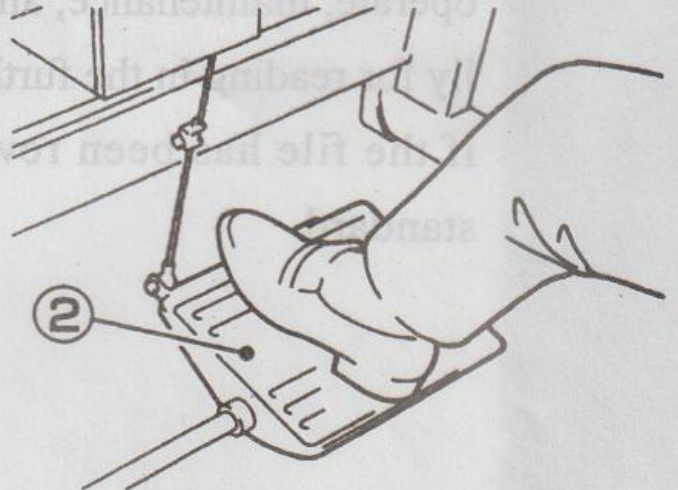

- Turn the power off before leaving the machine table.
- In the event of a power failure, be sure to turn the machine off.
- Check that the machine is securely grounded.

目 录

CONTENTS

■ 在使用之前 BEFORE OPERATING	页码
○ 台板加工图 Schematic diagram of the machine	1
○ 供油 Lubrication	2
○ 手动给油 Manual lubrication	3
○ 给HR装置供油 Filling the HR device with silicon oil	4
○ 穿线的方法 Threading	5
■ 试缝 TEST SEWING	
○ 压脚压力的调节 Adjusting the presser foot pressure	6
○ 差动比的调节 Adjusting the diff.feed ratio	7
○ 针脚长度的调节 Adjusting the stitch length	10
○ 线状态的调节 Adjusting the thread tension	11
■ 使用中的保养 MAINTENANCE DURING USE	
○ 缝纫机的清扫 Cleaning the machine	12
○ 换针 Replacing the needle	13
○ 检查机油的循环 Checking the oil circulation	14
○ 检查油质量, 更换油 Checking and replacing the oil filter	15
○ 换机油 Replacing the oil	16
○ 下刀片的更换 Replacing the lower knife	17
■ 调整基准表 ADJUSTING FIDUCIAL LIST	18
■ 各部件零件 ALL PARTS OF THE COMPONENTS	19

在使用之前
BEFORE
OPERATING

台板加工图

Schematic diagram of the machine table

请参照下图进行台板的加工

Cut the table referring to the diagram

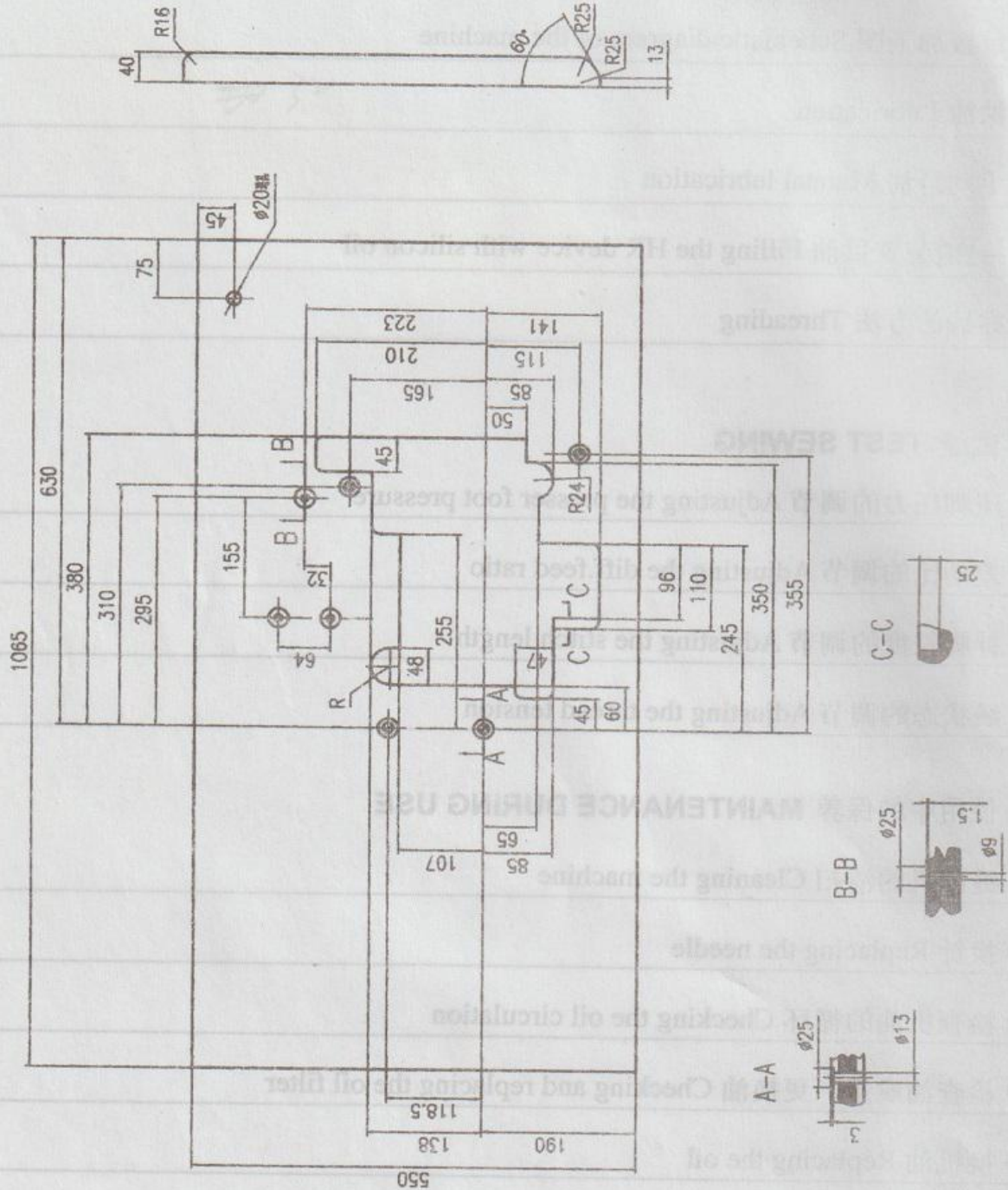

- 注
- 使用类似于日本产的马达时..... 306mm
 - 使用类似德国EFKA或QUICK公司马达时..... 334mm
- Notes
- Dimension for motors in Japan 306mm
 - Dimension for EFK motor 334mm

在使用之前
BEFORE
OPERATING

供油 Lubrication

加油量是使油面处于H线与L线之间为好。
当油面低于L线时，就要及时补充机油。

After filling the oil pan, the top of the indicator should lie between (H) and (L) lines.

Add oil, when the oil level indicator reaches or goes below (L).

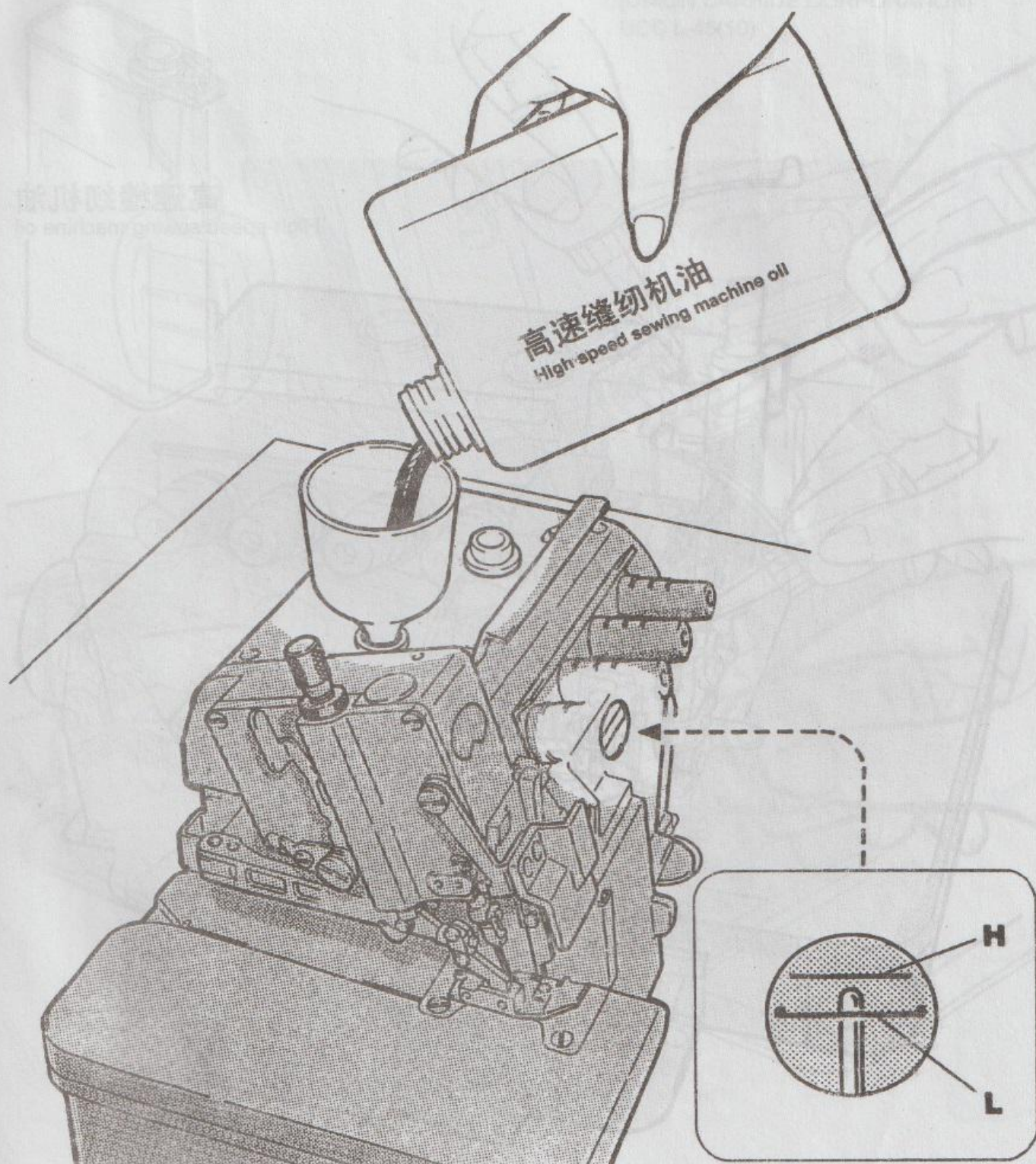

在使用之前
BEFORE
OPERATING

手动给油 Manual Lubrication

手动给油是在缝纫机最初开始使用时。或相当一段时间没使用了时，请供给2~3滴油。

Apply 2 or 3 drops of oil by hand when the machine is used for the first time or has been left unused for some time.

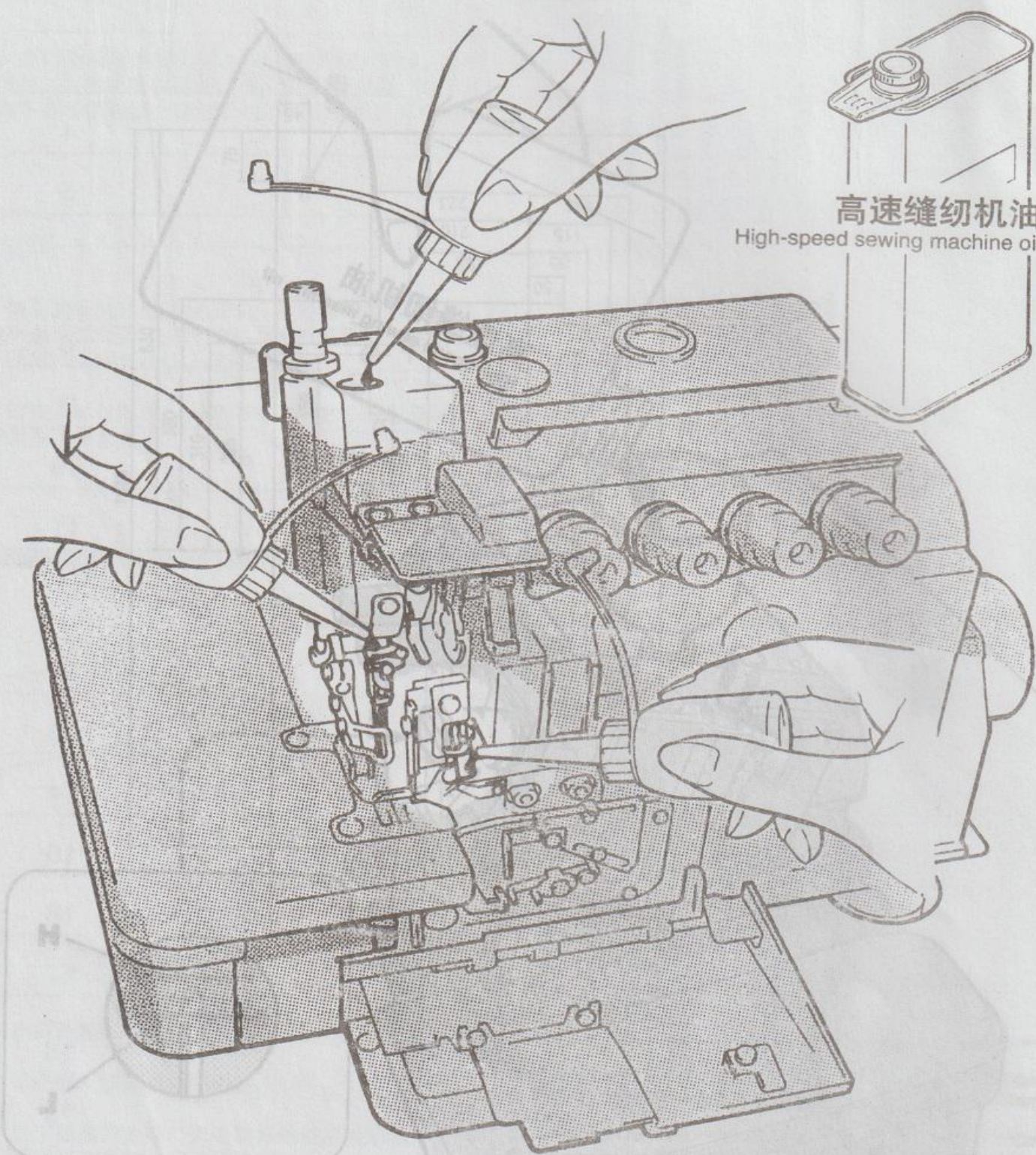

在使用之前
BEFORE
OPERATING

给HR装置供油

Filling the HR device with silicon oil

为防止断线，尽早给HR装置供油。

注：关于购买硅油，请咨询代理店或与公司营业部联系。

Fill the HR device with oil before it is too low in order to prevent needle thread breakage and fabric damage.

Note: Use Pegasus recommended silicon oil.
[UNION CARBIDE CORPORATION]
UCC L-45(10)

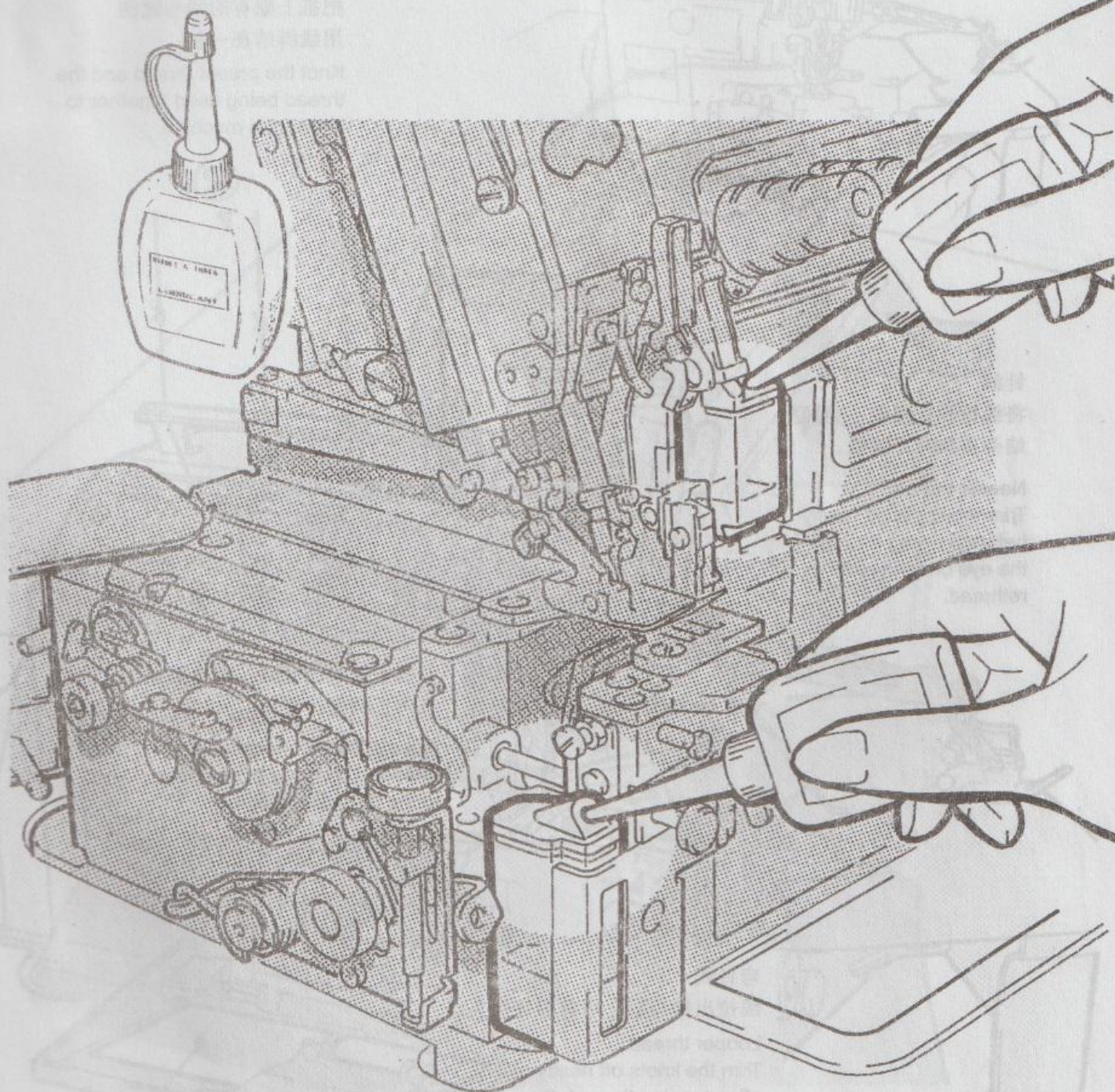

在使用之前
BEFORE
OPERATING

穿线的方法

Threading

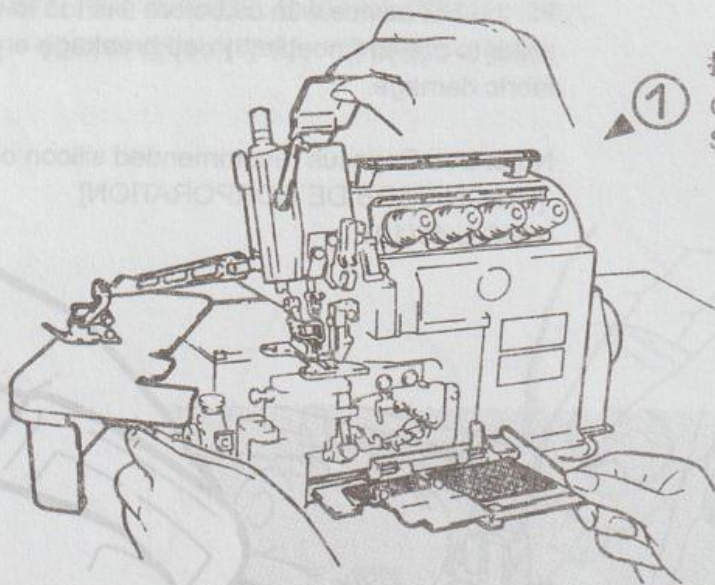

- ① 打开压脚杆及机盖(三处)
Open three covers.
Sewing the presser foot aside.

把机上原有的线与缝纫用线绑结在一起。

Knot the preset thread and the thread being used together to thread the machine.

针线
将线拉到针眼前，剪掉结头再次穿好针线。

Needle thread
Trim the knots off neatly before passing through the eye of the needle to rethread.

②

若机上原来没有线，请参照穿线图正确进行穿线。

Make sure the machine is threaded correctly by referring to the threading diagram.

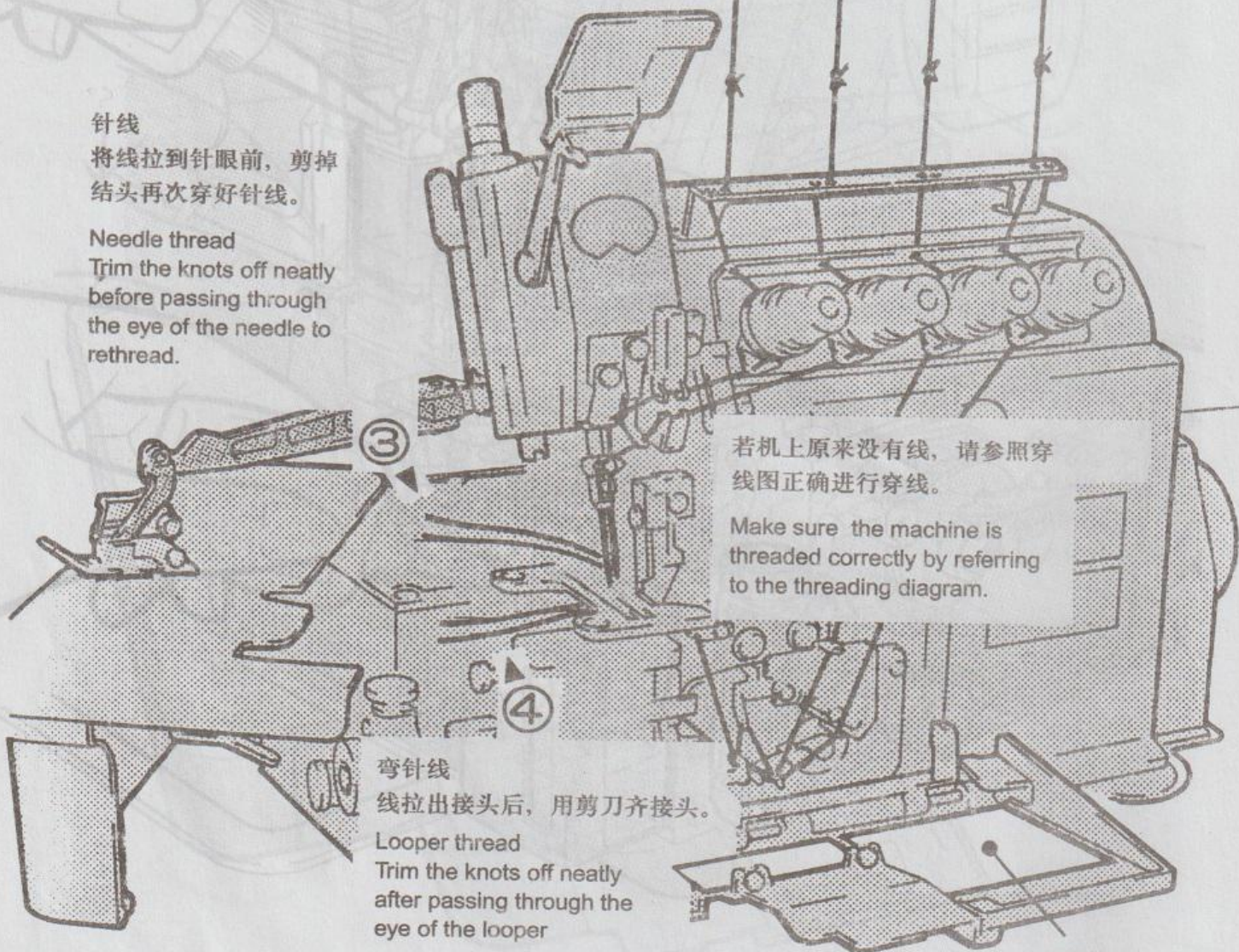

弯针线
线拉出接头后，用剪刀齐接头。

Looper thread
Trim the knots off neatly after passing through the eye of the looper

过线图

Threading diagram

压脚压力的调节

Adjusting the presser foot pressure

压脚压力的调节，松动螺母①，调节螺母②，在送布得到稳定状态下尽可能使用较弱的压力为好。

Loosen adjusting nut ① and turn adjusting nut ② to adjust the presser foot pressure. It should be as light as possible, yet be sufficient to obtain the proper stitch formation.

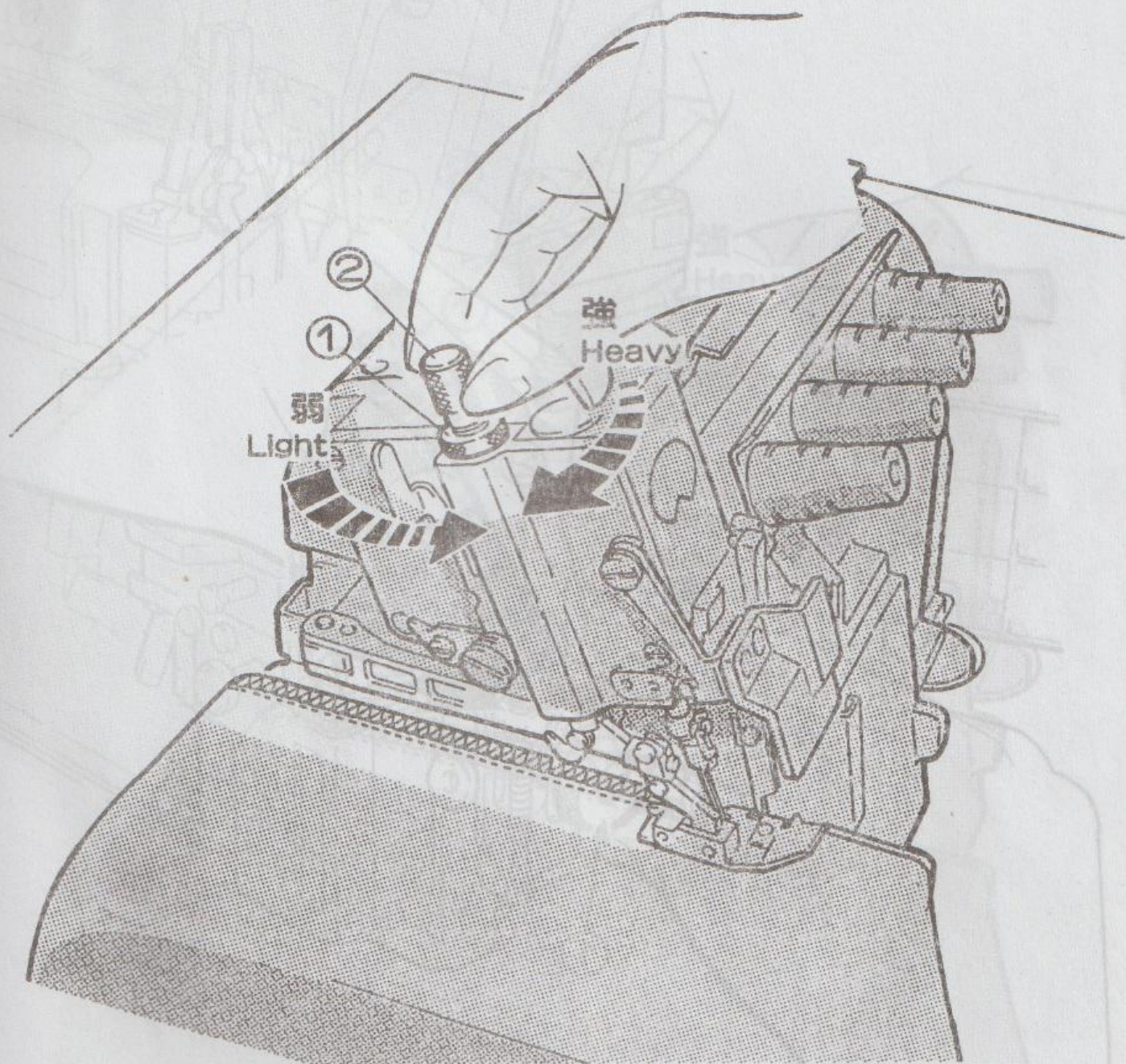

差动比的调节

Adjusting the diff. feed ratio

差动比的调节松开螺母①调节螺母②。

Loosen the adjusting nut① and turn the adjusting nut② to adjust the differential feed ratio.

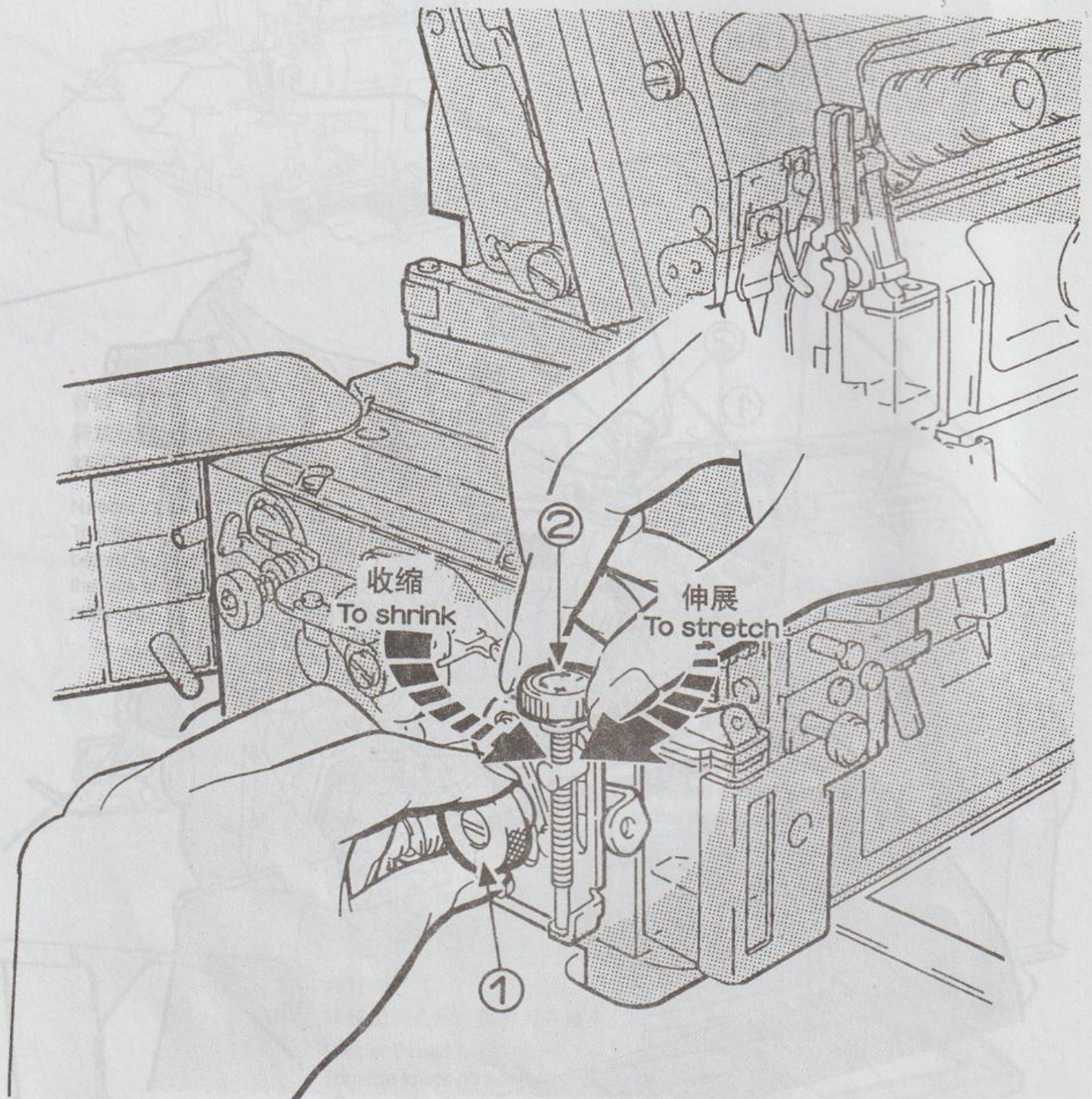

上送布牙压力的调节 Adjusting the top feed pressure

请松动螺母①拧动螺母②，对上送布牙压力进行调节。

在能得到稳定的线迹的范围内，请尽量调松。

Loosen the adjusting nut ① and turn adjusting nut ② to adjust the top feed pressure. It should be as light as possible, yet be sufficient to obtain the proper stitch formation.

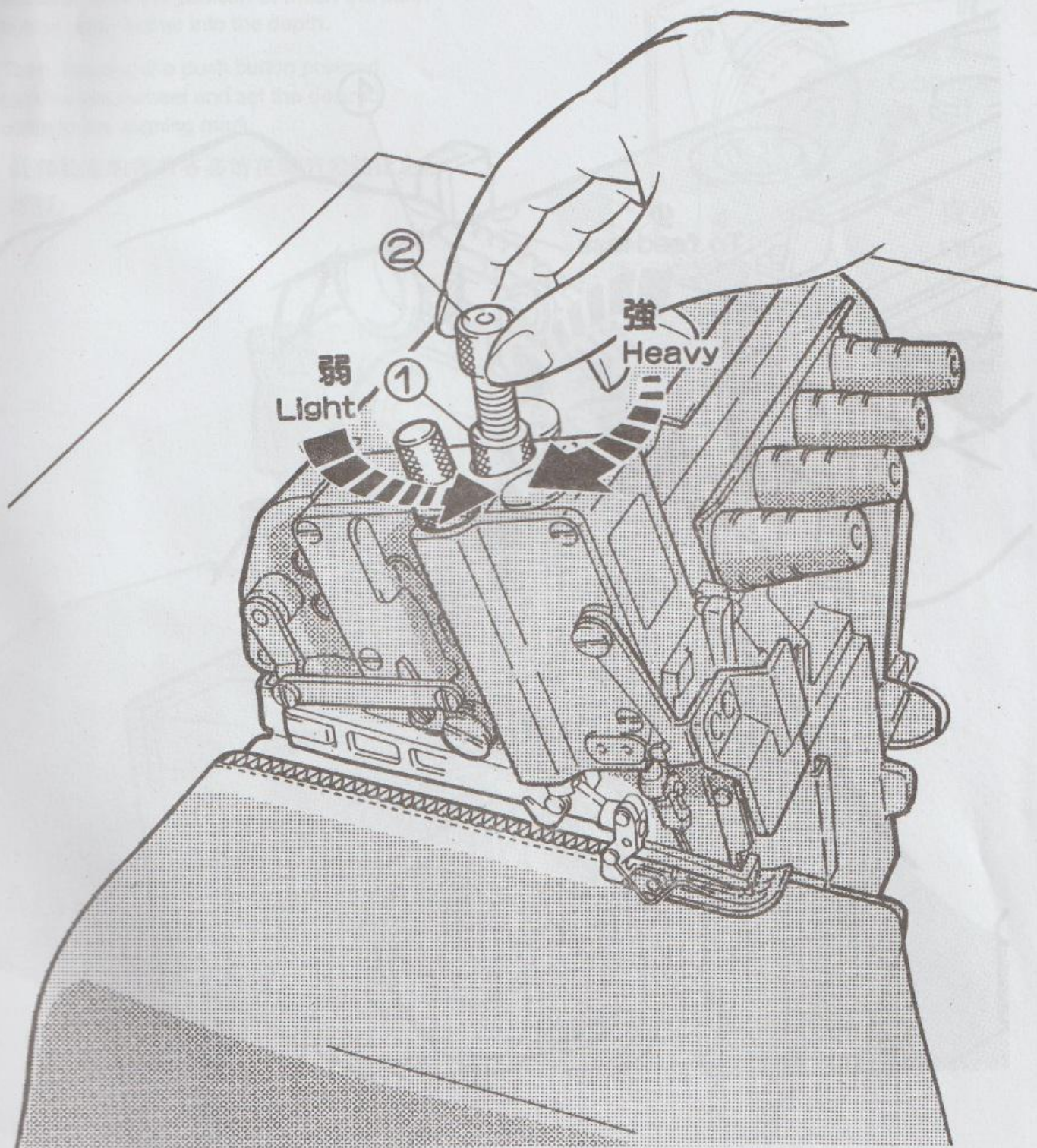

试缝
TEST SEWING

上送布牙前后量的调节

Adjusting the top feed front-to-back motion

请松动螺母①后拧动螺母②来调节上送布牙的前后量。

After loosening the adjusting nut ①, turn the adjusting nut ② to adjust the top feed front-to-back motion.

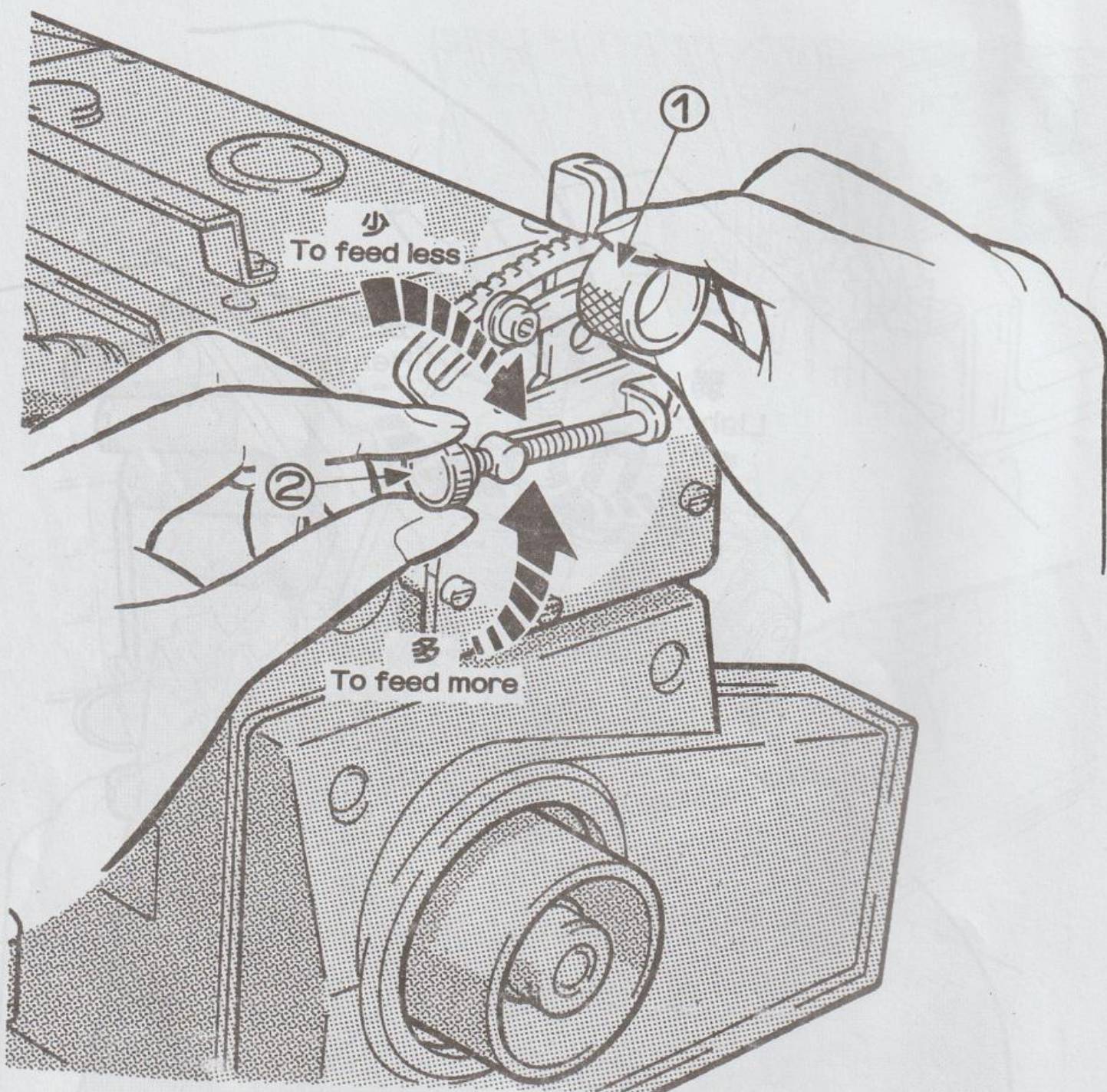

针脚长度的调节 Adjusting the stitch length

1. 摁住按钮，旋转手轮，按钮会陷进更深处。
2. 这时边摁住按钮，边转动手轮，使校准标记号对准所希望的数值。

While pressing the push button, turn the handwheel to seek the position at which the push button goes further into the depth.

Then, keeping the push button pressed, turn the handwheel and set the desired scale to the aligning mark.

注：针脚长度的调节务必请在调节差动比之后进行。

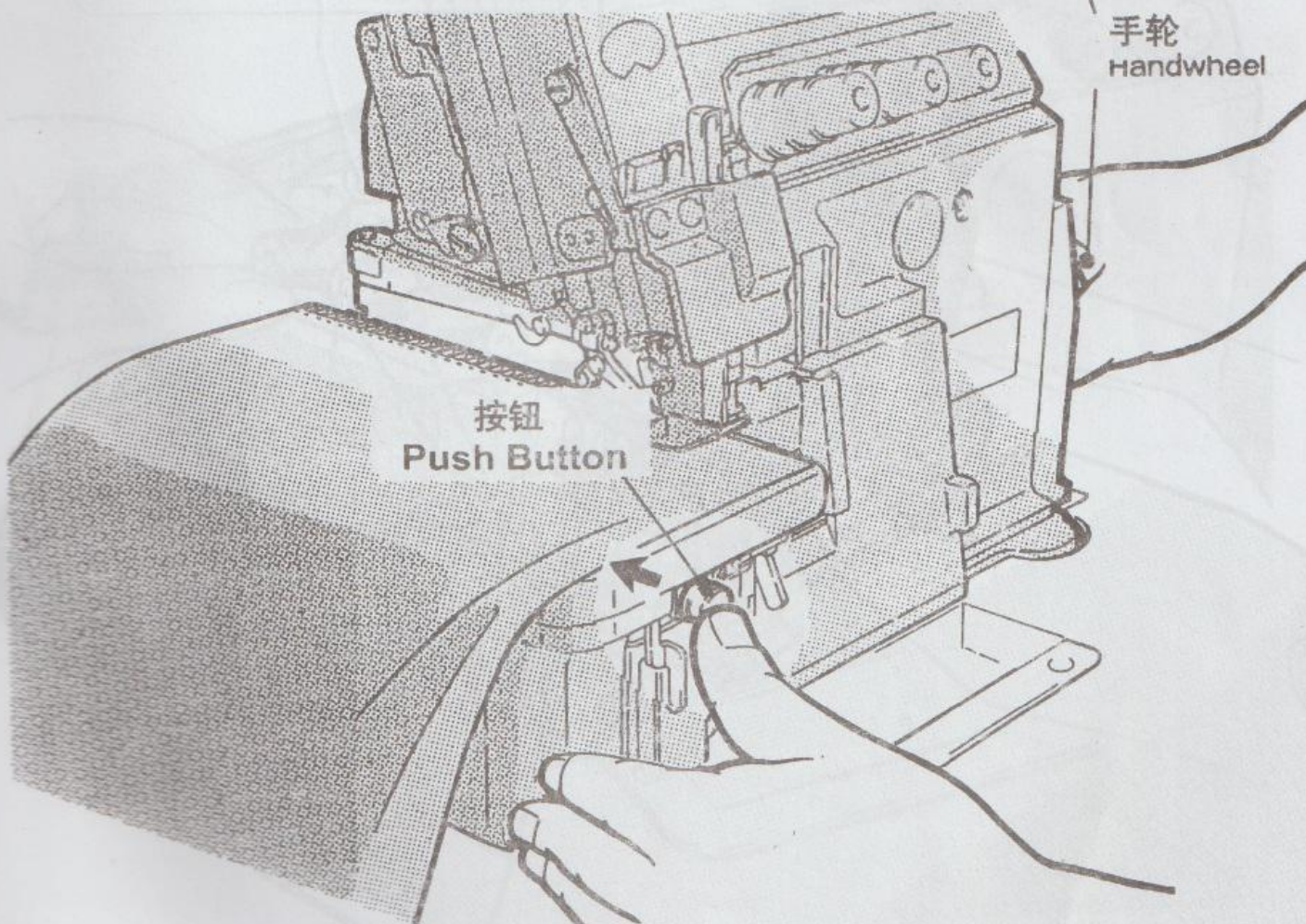
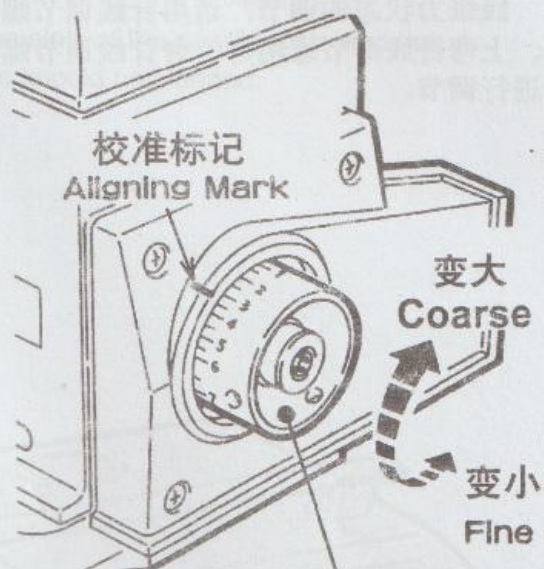

线状态的调节

Adjusting the thread tension

线张力状态的调节，请用针线调节螺帽①、上弯针线调节螺帽②、弯针线调节螺帽③来进行调节。

Make tension adjustments with the needle thread knob ①, the upper looper knob ②, and the lower looper knob ③.

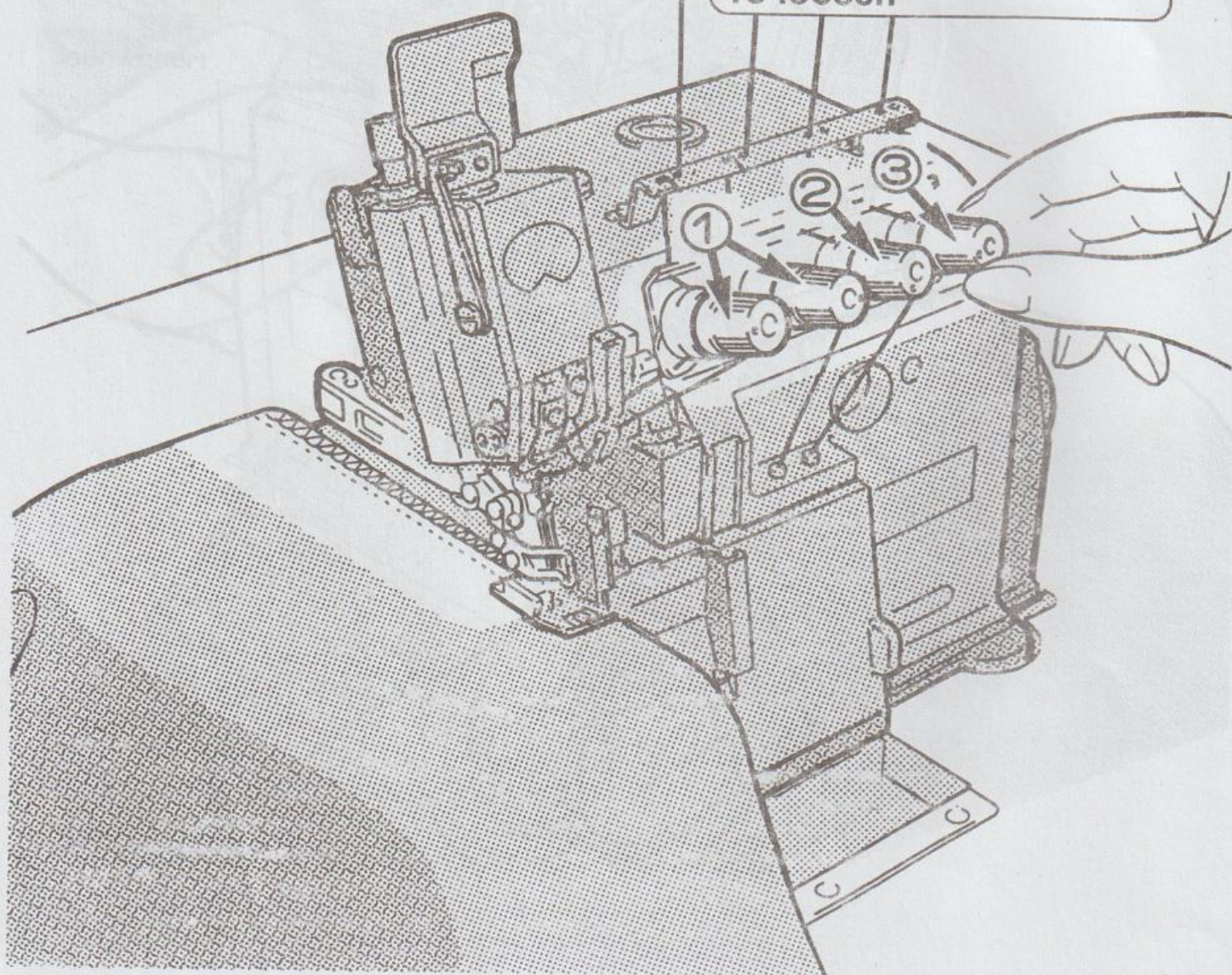

使用中的保养
MAINTENANCE
DURING USE

缝纫机的清扫 Cleaning the machine

缝纫机的清扫，以针板槽及送布牙周围为主。

Mainly the slots of the needle plate and the feed rows should be cleaned.

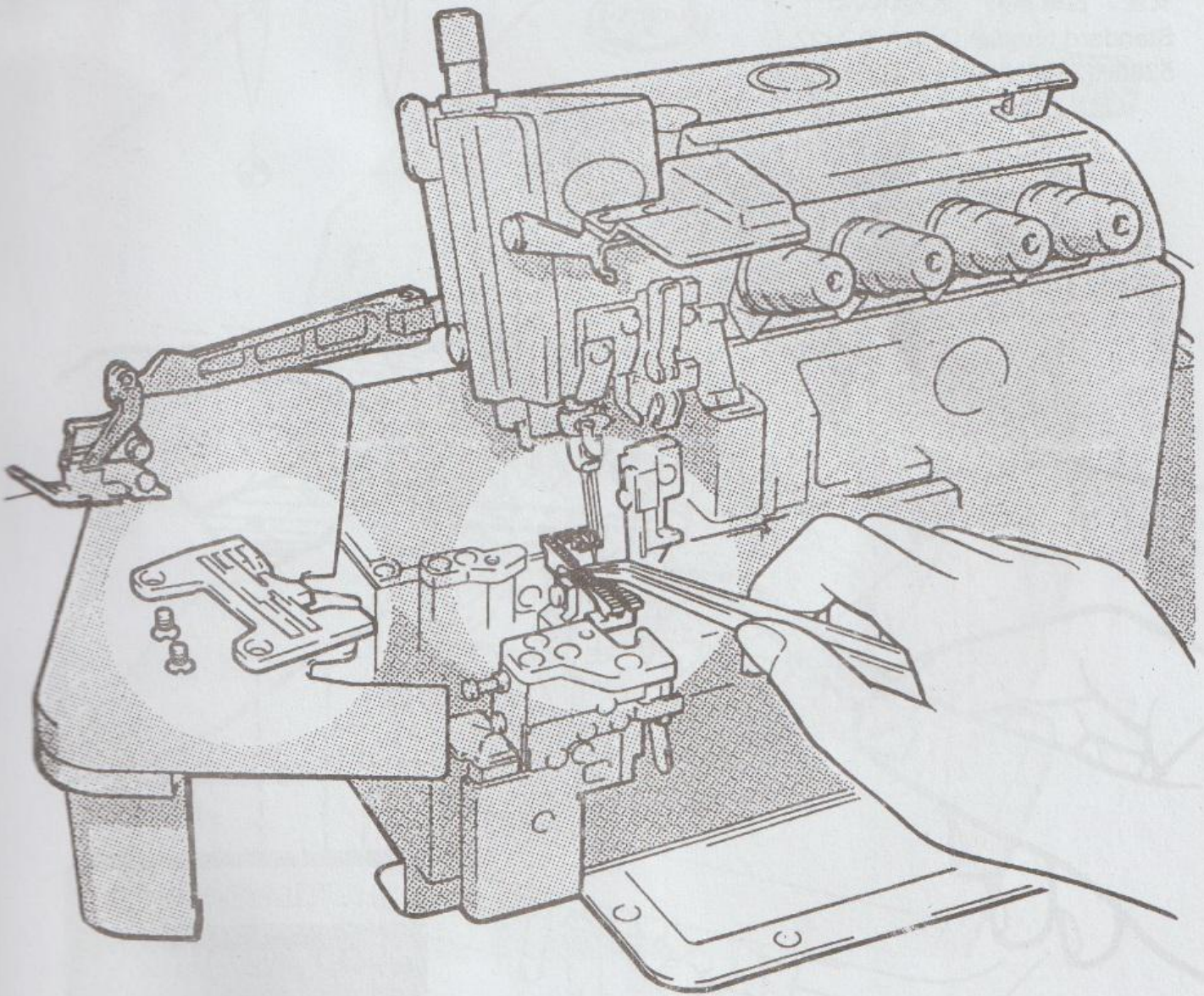

换针

Replacing the needle

准确辨认针的前后，请将针凹向着后方，即背向操作者进行安装。

针要牢固的插到孔的最深处。

- * Check the needle carefully to see that the scarf is turned to the rear of the machine.
- * Insert the needle to the proper depth, and fasten securely.

标准使用针：风琴DCX27

安全、包缝系列：风琴DCX5

Standard needle: Organ DCx27

5200H(3200H) series: Organ DCx5

OK! NO!

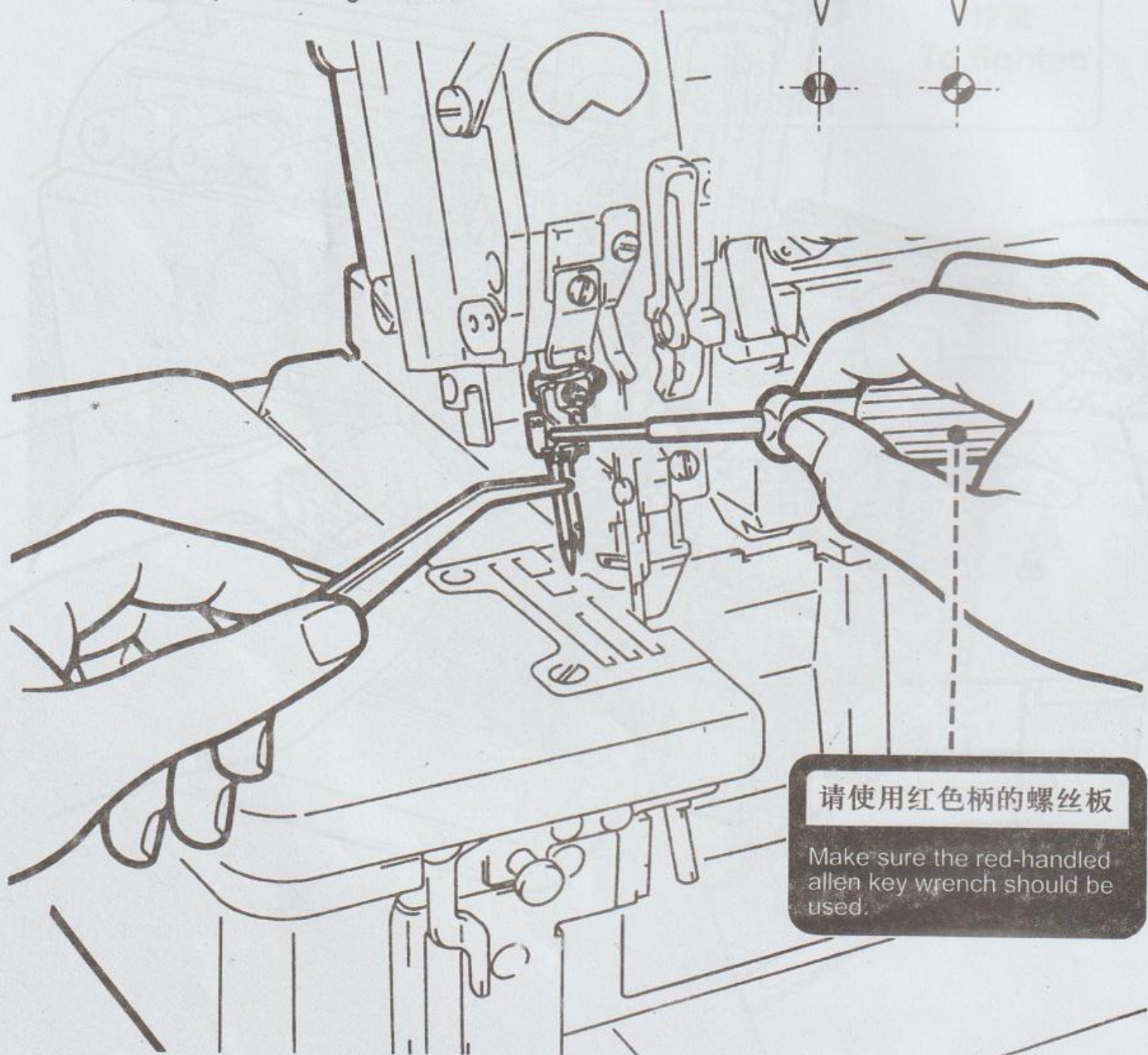
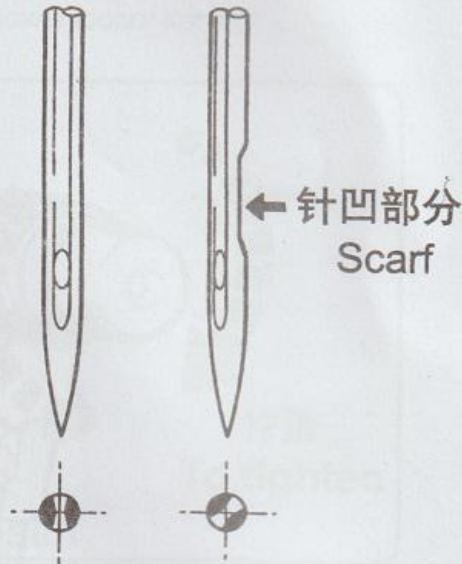

请使用红色柄的螺丝板

Make sure the red-handled allen key wrench should be used.

使用中的保养
MAINTENANCE
DURING USE

检查机油的循环

Checking the oil circulation

OK! 运转中
(Operating)

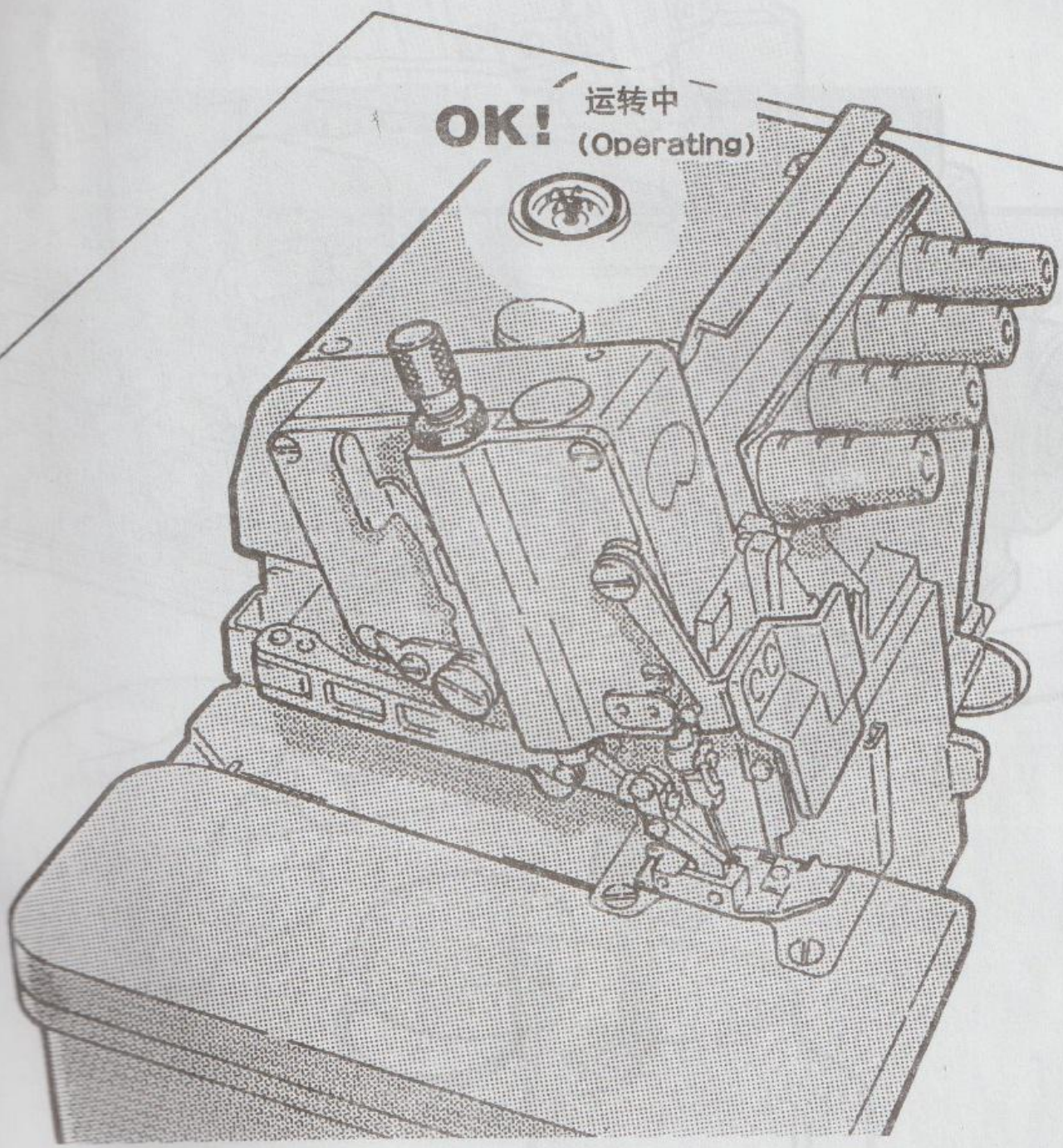

使用中的保养
MAINTENANCE
DURING USE

机油的检查和更换 Checking and replacing the oil filter

机油每6个月检查并更换。

Check and replace the oil filter every six months.

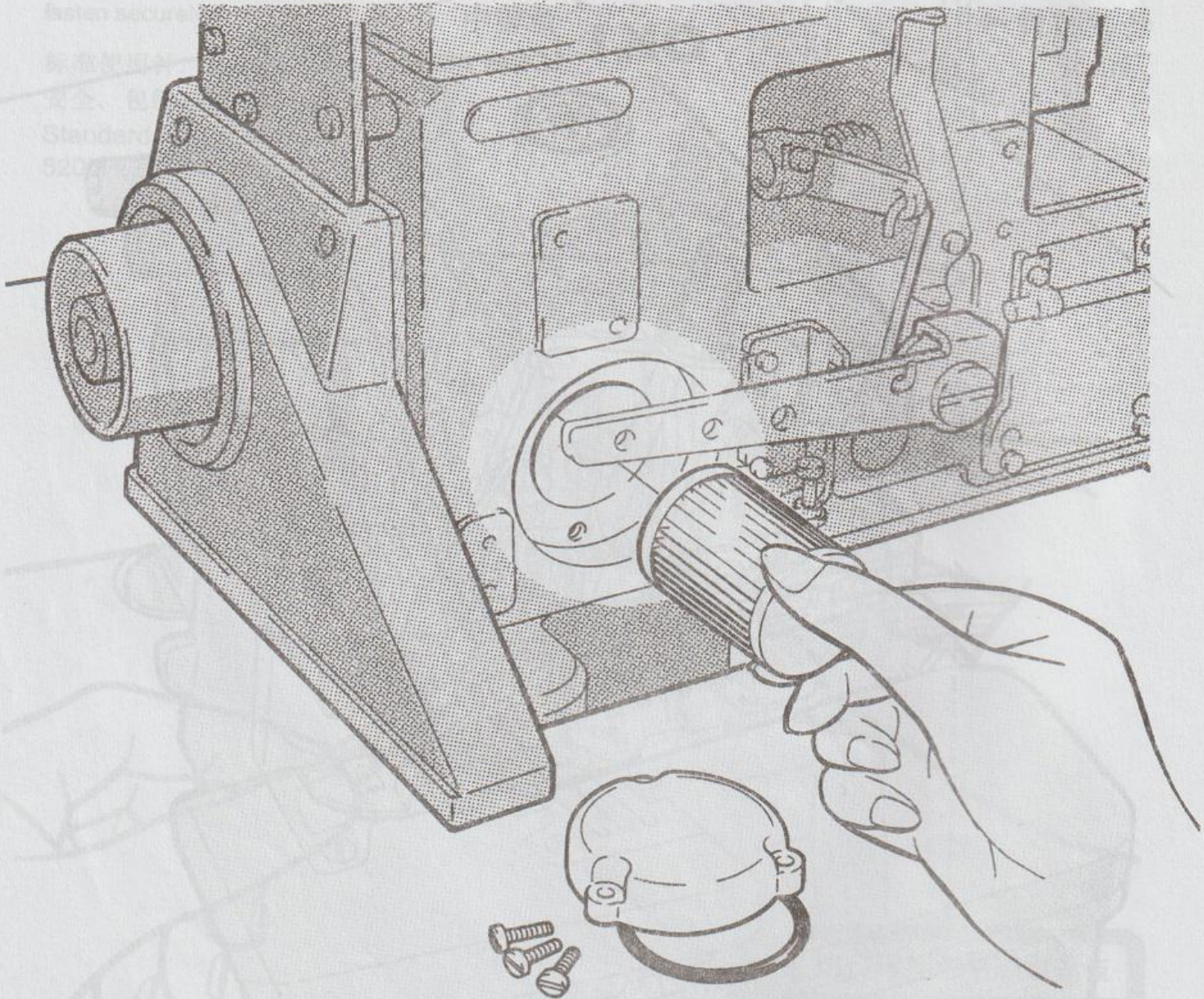

机油的更换，请在使用开始1个月后更换一次，然后，每6个月更换一次。
供油请参见第2页。

Replacing the oil one month after the first use and every six months there after. (See p2.)

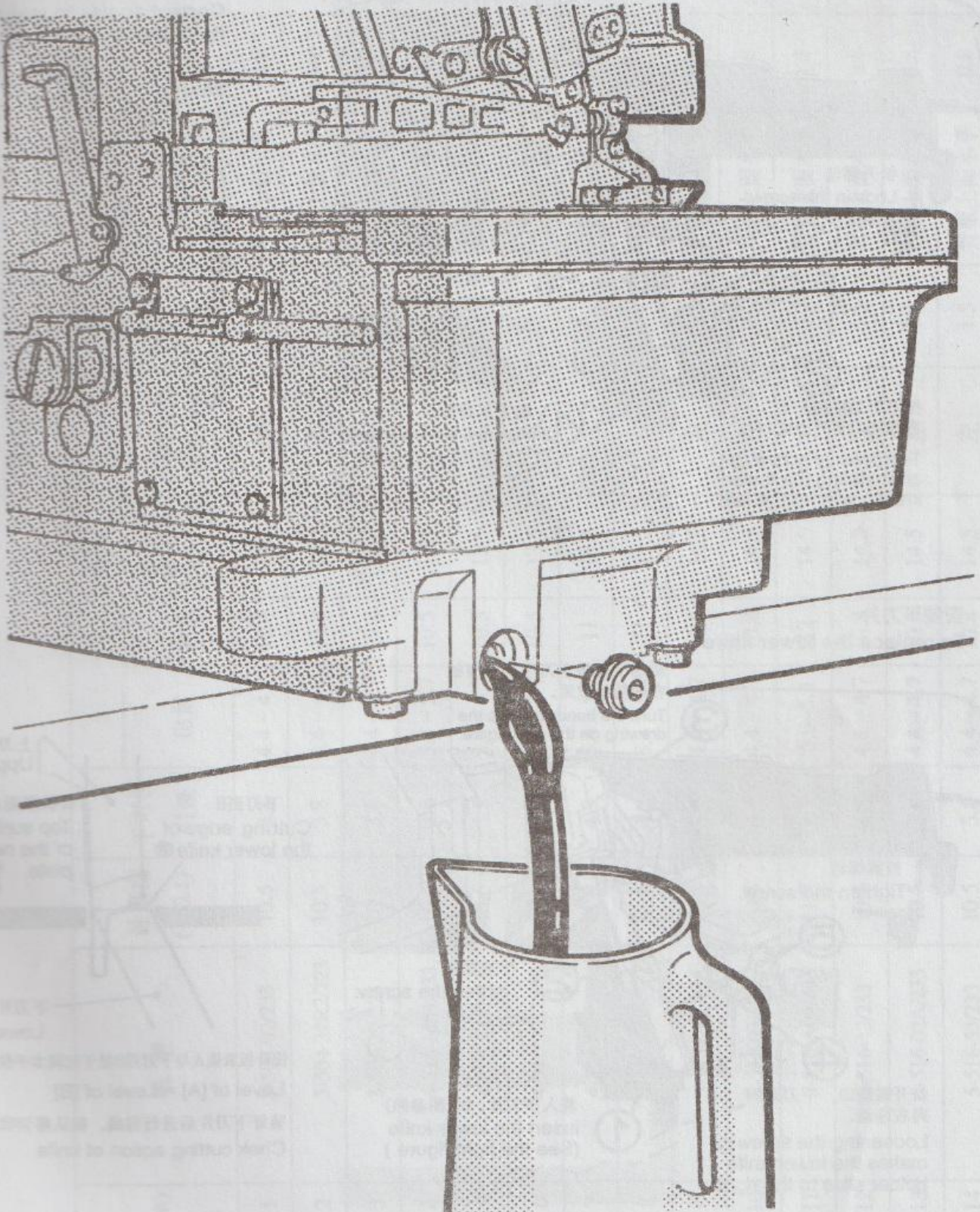

下刀片的更换 Replacing the lower knife

卸下下刀片 To remove the lower knife

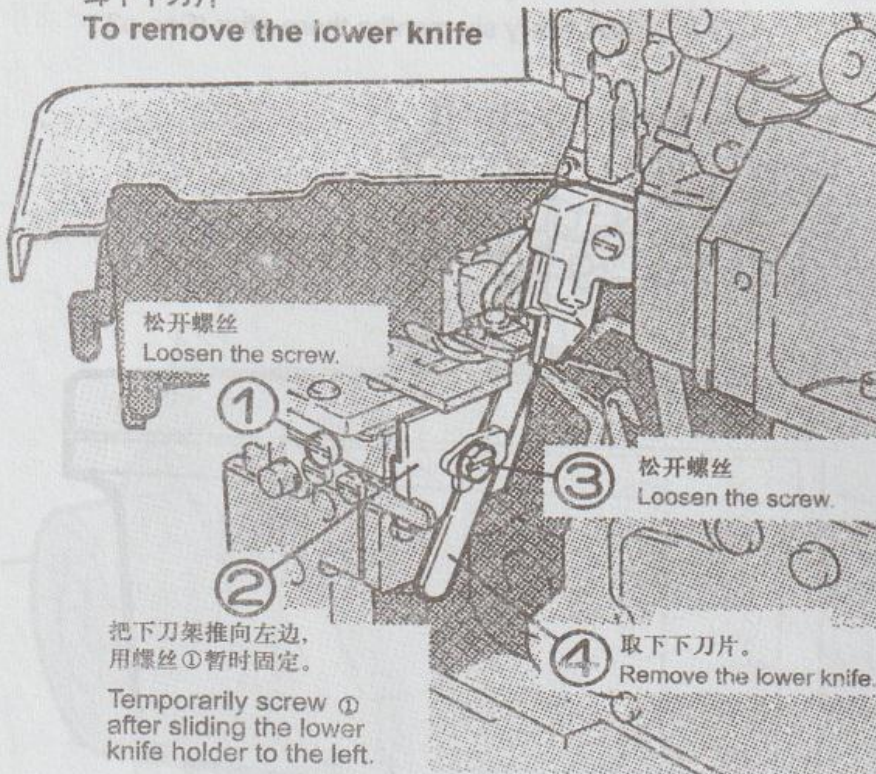

下刀片正确的研磨角度 Correct angles to sharpen the lower knife

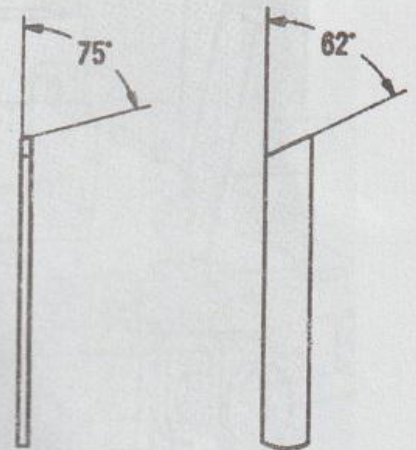

安装下刀片 To replace the lower knife

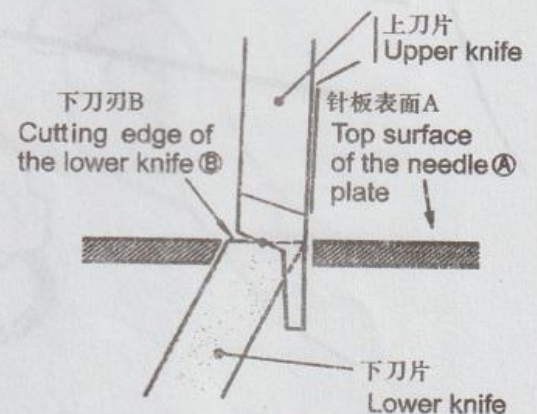
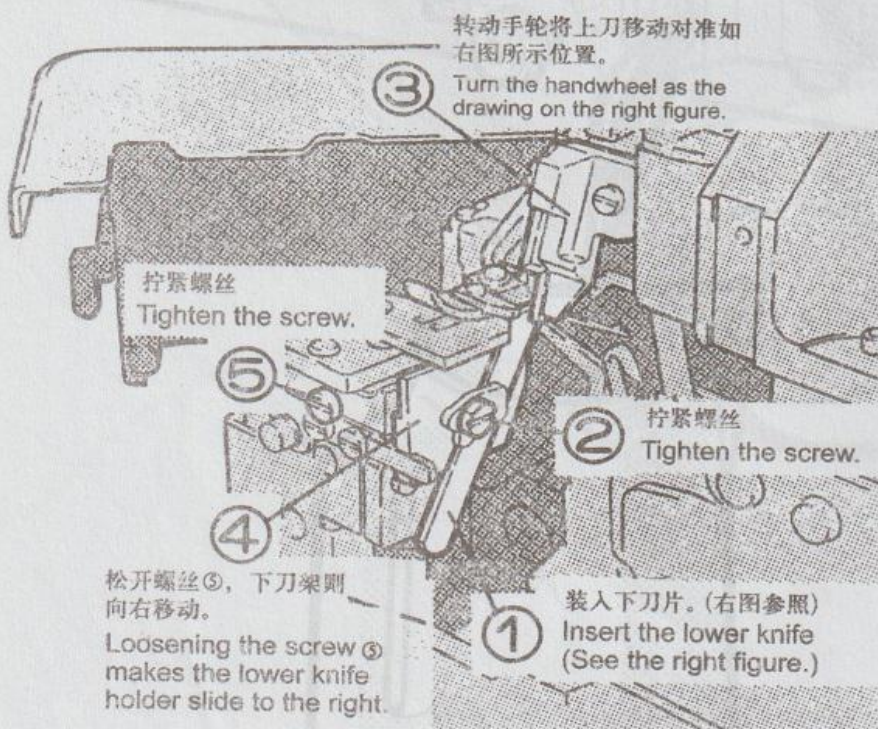

使针板表面A与下刀刃B处于相同水平位置。

Level of [A] = Level of [B]

装好下刀片后进行剪线，确认剪切状况

Check cutting action of knife

调整基准表

NO.	机型	针高度 (±0.1)	下弯针 引量	上弯针				二重环 弯针引 量	送牙				
				出量	高度	弯针架 左右位置	上弯针座 安装方向		送齿倾斜度	送齿高度	上送牙高 度(按下送 齿上面)	辅助送 齿段差	送布偏 心量
1	3-504-02/233	10.5	3.8	4.4~4.7	10.8	14.5	左	----	针板上面水平	0.8	0.2	0.5	0.35~2
2	3-504-32R2/223	10.5	3.8	4.4~4.7	10.8	14.5	左	----	针板上面水平	0.6~0.7	0.2	0.3	0.35~1.7
3	3-505-12/223	10.5	3.8	4.4~4.7	10.8	14.5	左	----	针板上面水平	0.8	0.2	0.5	0.35~2
4	4-514-M03/333	10.5	3.8	5.4~5.7	10.5	13.5	右	----	针板上面水平	0.8	0.2	0.5	0.35~2
5	4-514-43P2/333	10.5	3.8	5.4~5.7	10.5	13.5	右	----	针板上面水平	0.8	0.2	0.5	0.35~2
6	4-514-M53/333	10.5	3.8	5.4~5.7	10.5	13.5	右	----	针板上面水平	0.8	0.2	0.5	0.35~1.7
7	4-514-54/433	11.9	4.2	5.4~5.7	11	13.5	左	----	针板上面水平	1	0.2	0.5	0.35~2
8	4-514-54/443	11.9	4.2	5.4~5.7	11	13.5	左	----	针板上面水平	1	0.2	0.5	0.35~2
9	5-516-02A/223	10.5	3.8	4.4~4.7	10.8	14.5	左	1.5	针板上面水平	0.8	0.2	0.5	0.35~2
10	5-516-03/333	10.5	3.8	4.4~4.7	10.8	14.5	左	1.5	针板上面水平	0.8	0.2	0.5	0.35~2
11	5-516-A04/435	11.9	4.2	5.0~5.3	12	14.5	左	1.7	针板上面水平	1.1	0.2	0.5	0.35~2
12	5-516-42/233	10.5	3.8	4.4~4.7	10.8	14.5	左	1.5	针板上面水平	0.8	0.2	0.5	0.35~2
13	5-516-02A/233	10.5	3.8	4.4~4.7	10.8	14.5	左	1.5	针板上面水平	0.8	0.2	0.5	0.35~2
14	5-516-53/233	10.5	3.8	4.4~4.7	10.8	14.5	左	1.5	针板上面水平	0.8	0.2	0.5	0.35~2

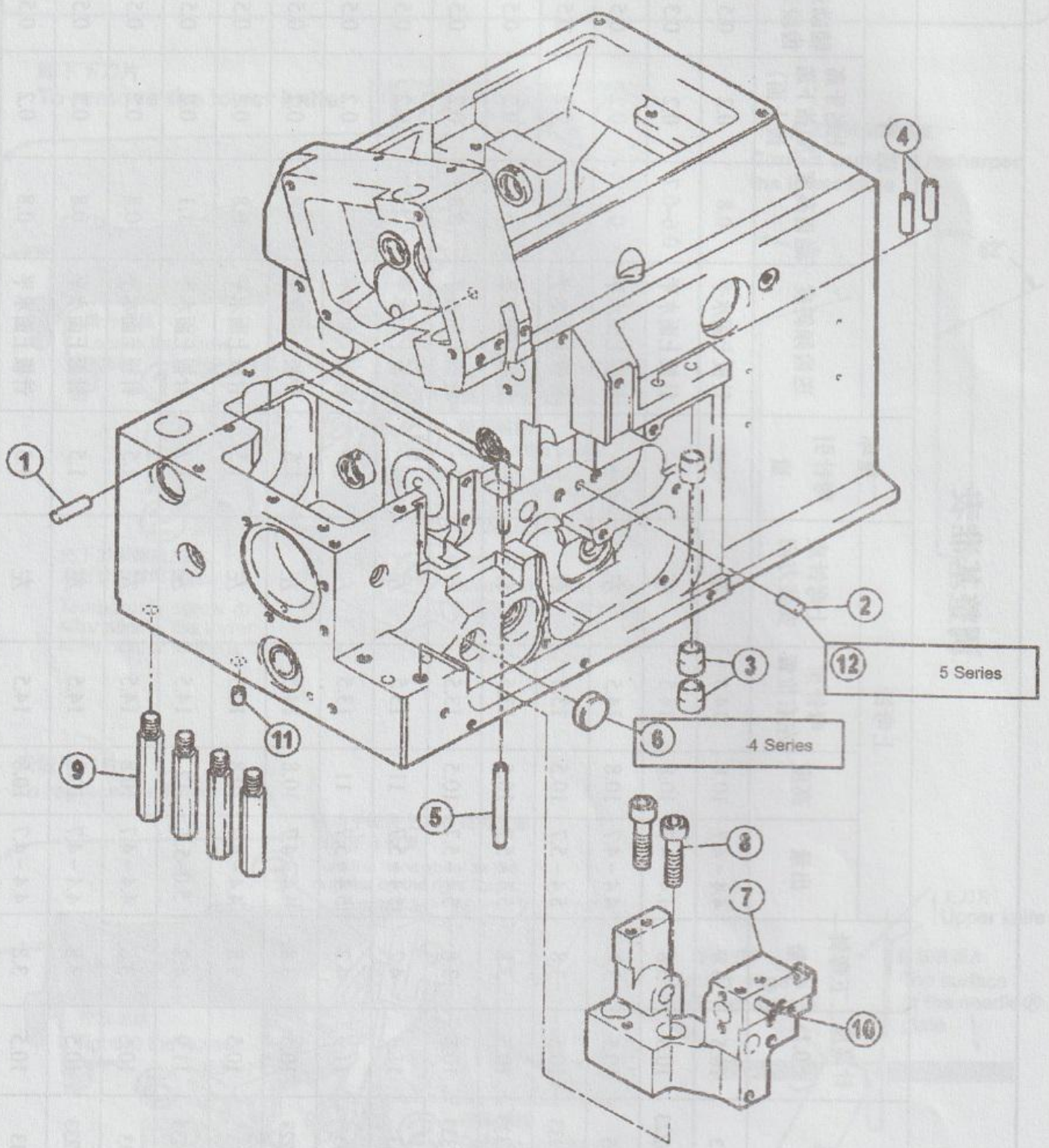

一、机壳部件/Machine Bed Frame

序号 NO	图号 Parts No.	名称	Description	数量 (Number)		
				三线 Three-thread	四线 Four-thread	五线 Five-thread
1	240333	销5.5 × 16	Pin	1	1	1
2	201002	销5 × 10	Pin	1	1	1
3	210194	导向套	Indicator guide	2	2	2
4	240325	过线管	Pipe	2	2	2
5	240299	销4 × 40	Pin	1	1	1
6	208173	送布轴油封	Plug	1	1	0
7	270008-91	下刀座	Bracket Assembly	1	1	1
8	4511	螺钉M6 × 25	Screw	2	2	2
9	270047	支柱	Bed Pin	4	4	4
10	240342	销5 × 14	Pin	1	1	1
11	----	工艺孔销	Pin	1	1	1
12	----	厚料摇杆定位销	Pin	0	0	1(厚料)
	270001-9S	机壳	Machine Bed Complete	1	1	1
	----	上轴右套	Sleeve	1	1	1
	----	上轴左套	Sleeve	1	1	1
	----	送布右轴套	Sleeve	1	1	1
	----	上刀轴左套	Sleeve	1	1	1
	----	弯针前轴套	Sleeve	2	2	1
	----	上弯针后轴套	Sleeve	1	1	1
	----	主轴套筒	Sleeve	1	1	1
	----	差动轴套	Sleeve	1	1	1
	----	上刀轴右套	Sleeve	3	3	6

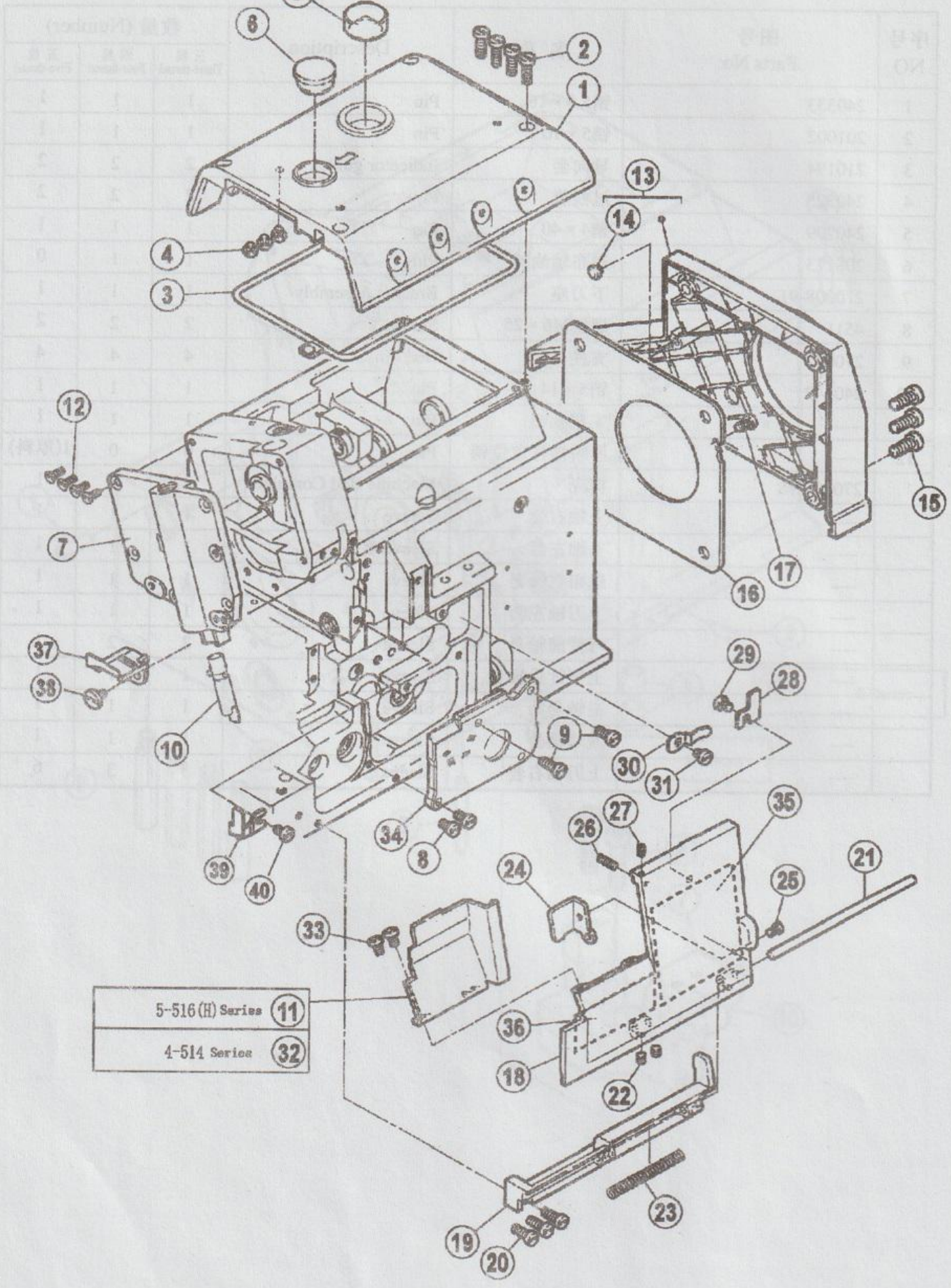

二、机壳机罩部件(1)/Cover(1)

序号 NO	图号 Parts No.	名称	Description	数量 (Number)		
				三线 Three-thread	四线 Four-thread	五线 Five-thread
1	270020-SD	上罩	Top Cover	1	1	1
2	7020	螺钉M4 × 10	Screw	4	4	4
3	270021	密封垫	Gasket	1	1	1
4	240305	减震垫	Cushion Rubber	3	3	3
5	179107-05	油窗	Oil sight window	1	1	1
6	240110	油塞	Plug	1	1	1
7	270010-UD	侧盖	Side Cover	1	1	1
8	7020	螺钉M4 × 10	Screw	2	2	2
9	7021	螺钉M4 × 12	Screw	2	2	2
10	274011-91	压脚杆组件	Presser Bar	1	1	1
11	270013	左前盖	Front Cover (left)	0	0	1
12	7044	螺钉M4 × 10	Screw	4	4	4
13	270024-9U	皮带罩	Belt Cover Assembly	1	1	1
14	----	----	----	----	----	----
15	7176	螺钉M6 × 14	Screw	3	3	3
16	270025	风扇罩	Fan Cover	1	1	1
17	7019	螺钉M4 × 7.5	Screw	1	1	1
18	270011-UD	右前盖	Front Cover (right)	1	1	1
19	270014	铰链	Hinge	1	1	1
20	7021	螺钉M4 × 12	Screw	3	3	3
21	240043	铰链销	Pin	1	1	1
22	4543	螺钉M4 × 4	Screw	2	2	2
23	240301	铰链销弹簧	Spring	1	1	1
24	270018	锁紧板	Latch	1	1	1
25	7009	螺钉M3 × 4.5	Screw	1	1	1
26	4574	螺钉M3 × 12	Screw	1	1	1
27	4535	螺钉M3 × 4	Screw	1	1	1
28	270017	锁紧板	Latch	1	1	1
29	7017	螺钉M4X4.7	Screw	1	1	1
30	210044	前罩板卡簧1	Flat Spring	1	1	1
31	7017	螺钉M4X4.7	Screw	1	1	1
32	270012	左前盖	Front Cover (left)	1	1	0
33	7018	螺钉M4 × 5	Screw	2	2	2
34	270028	前盖板	Side Cover	1	1	1
35	----	穿线图	Threading diagram	1	1	1
36	----	穿线图	Threading diagram	0	0	1
37	270079	外罩	Cover	1	1	1
38	7066	螺钉	Serew	1	1	1
39	270081	送料压板	Cover	1	1	1
40	7018	螺钉M4 × 5	Screw	1	1	1

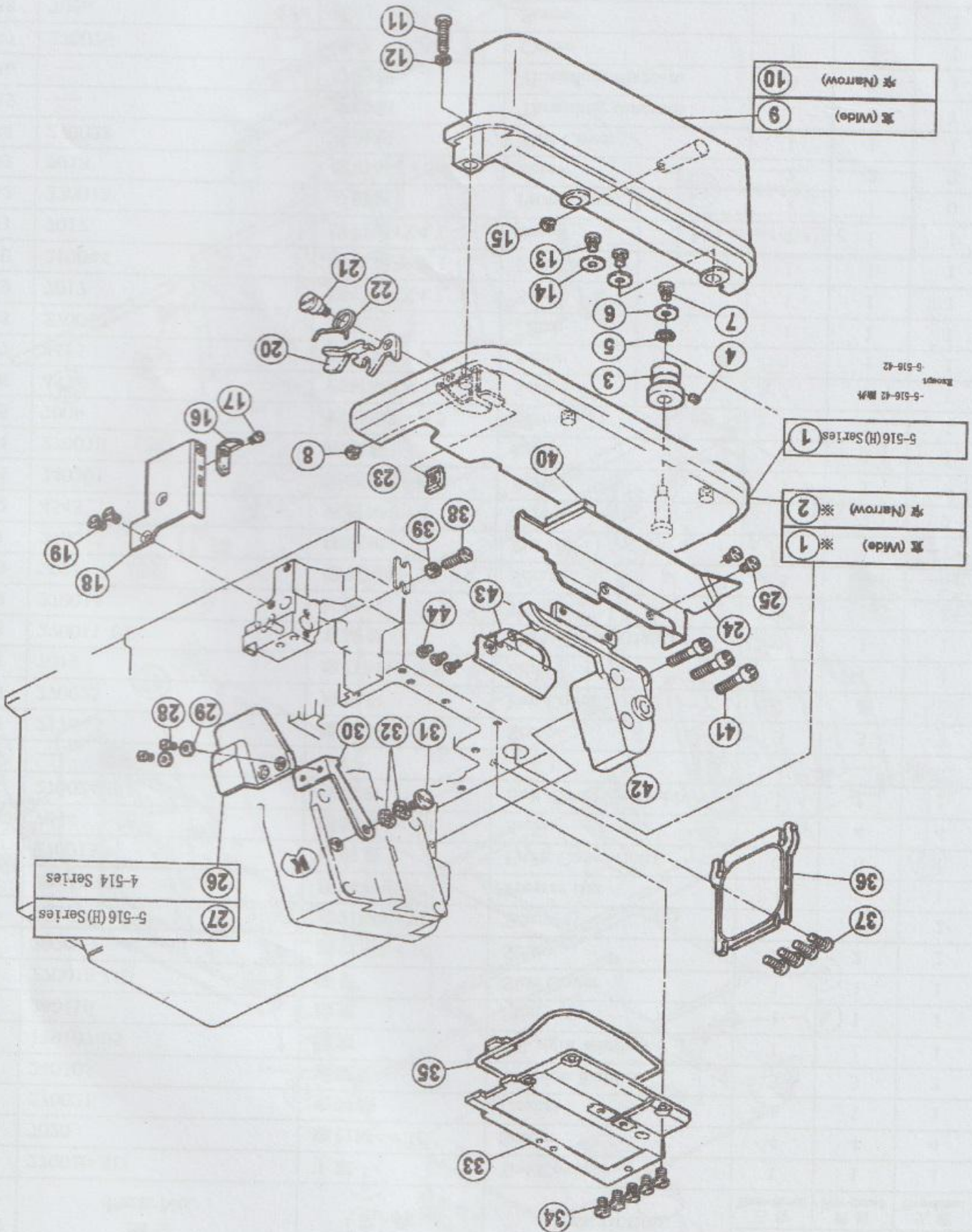

三、机壳机罩部件(2)/Cover(2)

序号 NO	图号 Parts No.	名称	Description	数量 (Number)		
				三线 Three-thread	四线 Four-thread	五线 Five-thread
1	270035	缝台组件(宽)	Cloth Plate	0	0	1
2	270037	缝台组件(窄)	Cloth Plate	1	1	0
3	270042	套筒	Bushing	1	1	1
4	4543	螺钉M4×4	Screw	1	1	1
5	---	止动垫圈6	Washer	1	1	1
6	204115	垫圈	Washer	1	1	1
7	7018	螺钉M4×5	Screw	1	1	1
8	240305	减震垫	Cushion Rubber	1	1	1
9	270030-UB	侧盖组件(宽)	Side Cover (Wide)	0	0	1
10	270031-UB	侧盖(窄)	Side Cover (Narrow)	1	1	0
11	7025	螺钉M4×17.5	Screw	1	1	1
12	201252	垫圈4	Spring Washer	1	1	1
13	7018	螺钉M4×5	Screw	2	2	2
14	240343	垫片	Washer	2	2	2
15	240305	减震垫	Cushion Rubber	1	1	1
16	270049	下刀座前垫护板	Latch	1	1	1
17	7180	螺钉M3.5×4.5	Screw	1	1	1
18	270015	挡板	Plate	1	1	1
19	7170	螺钉M4×7.5	Screw	2	2	2
20	270043	连杆	Lever	1	1	1
21	7172	螺钉M4	Screw	1	1	1
22	270044	扭簧	Spring	1	1	1
23	270045	托架	Bracket	1	1	1
24	270019	布料挡板	Fabric Guide	1	1	1
25	7019	螺钉M4×7.5	Screw	2	2	2
26	270032	防护罩	Eye Guide	1	1	0
27	270033	防护罩	Eye Guide	0	0	1
28	7062	螺钉M3×6	Screw	2	2	2
29	---	垫圈3	Washer	2	2	2
30	270034	托架	Bracket	1	1	1
31	7066	螺钉M4	Screw	1	1	1
32	210307	垫圈	Washer	2	2	2
33	270022	上盖	Bed Cover Plate Assy.	1	1	1
34	7084	螺钉M4×8	Screw	5	5	5
35	270023	密封垫	Gasket	1	1	1
36	270026	后窗板	Cover Plate	1	1	1
37	7020	螺钉M4×10	Screw	4	4	4
38	7023	螺钉M4×16	Screw	1	1	1
39	4821	螺母M4	Nut	1	1	1
40	---	油盘垫	Oil Reservoir Cushion	1	1	1
41	4511	螺钉M6×25	Screw	3	3	3
42	270068	支架	Bracket	1	1	1
43	270067	外罩	Cover	1	1	1
44	7154	螺钉M3×3.5	Screw	3	3	3

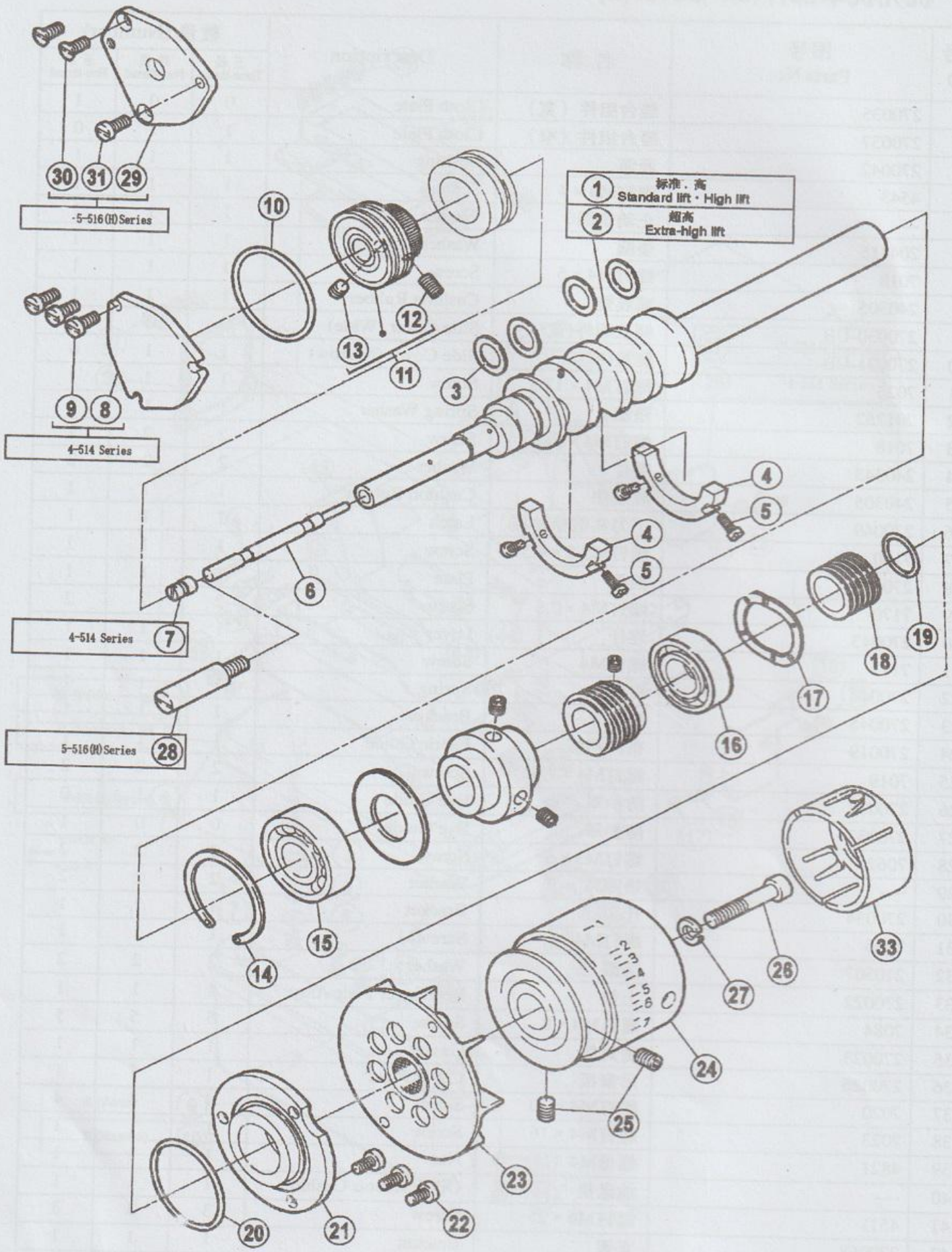

四、主轴部件/Crankshaft Drive Mechanism

序号 NO	图号 Parts No.	名称	Description	数量 (Number)		
				三线 Three-thread	四线 Four-thread	五线 Five-thread
1	270500A	主轴	Crankshaft	1	1	0
2	270500C	主轴	Crankshaft	0	0	1
3	---	连杆垫片	Washer	4	4	4
4	270502	平衡块	Blance Weight	2	2	2
5	7011	螺钉M3 × 8	Screw	4	4	4
6	270503	销	Pin	1	1	1
7	4541	螺钉M6 × 8	Screw	1	1	0
8	270508	前轴承盖	Cover	1	1	0
9	7019	螺钉M4 × 7.5	Screw	3	3	0
10	240340	O型圈40 × 1.8	O Ring	1	1	1
11	270507-91	轴承6202LB	Ball Bearing	1	1	1
12	4572	螺钉5 × 10	Screw	1	1	1
13	4514	螺钉M5 × 5	Screw	1	1	1
14	240335	卡簧	Ring	1	1	1
15	212987	轴承6203	Ball Bearing	1	1	1
16	211526	轴承6203LLU	Ball Bearing	1	1	1
17	240306	垫圈32	Washer	4	4	4
18	---	主轴中轴套	Oil Seal	1	1	1
19	210057	O型圈17 × 1.8	O Ring	1	1	1
20	240307	O型圈41 × 1.8	O Ring	1	1	1
21	211528	后轴承盖	Right Cover	1	1	1
22	7020	螺钉M4 × 10	Screw	3	3	3
24	270504-UD	皮带轮(刻好字)	Machine Pulley	1	1	1
25	4541	螺钉M6 × 8	Screw	2	2	2
26	4523	螺钉M6 × 35	Screw	1	1	1
27	204293	垫圈6	Spring Washer	1	1	1
28	270510	主轴接轴	Pin	0	0	1
29	270509	前轴承盖	Cover	0	0	1
30	7044	螺钉M4 × 10	Screw	0	0	2
31	7020	螺丝M4 × 10	Screw	0	0	1
32	270526	皮带轮罩	Cover	1	1	1
33	---	O型圈30 × 1.2	O Ring	2	2	2

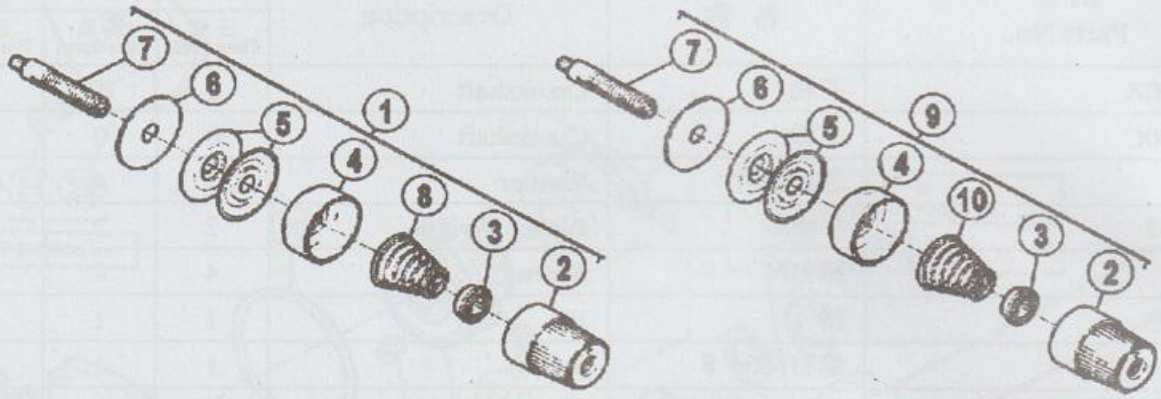

■ 1 针 (1-needle)

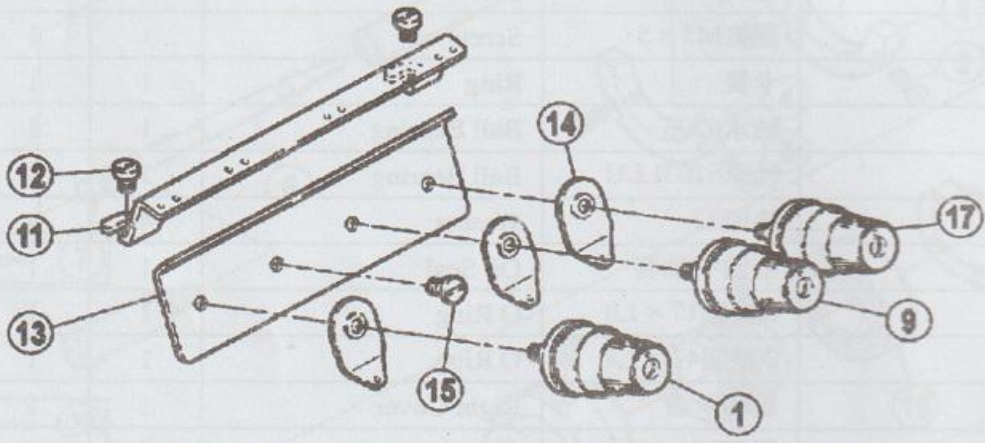

■ 2 针 (2-needle)

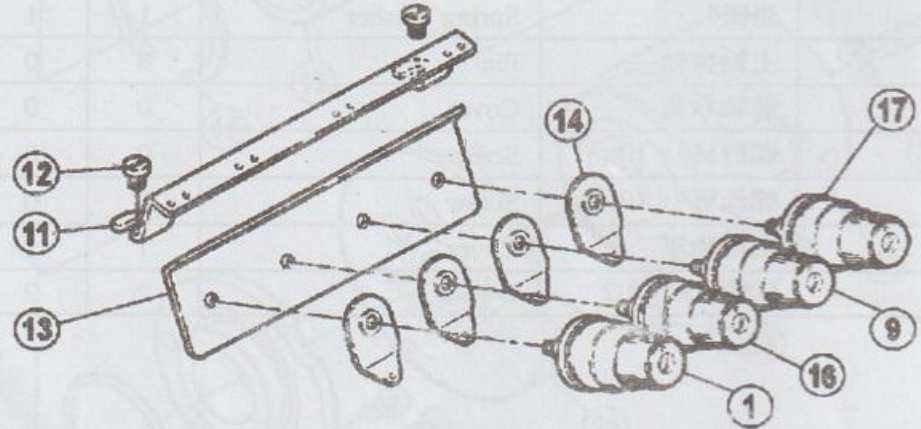

五、夹线部件/Thread Tension Mechanism

序号 NO	图号 Parts No.	名称	Description	数量 (Number)		
				三线 Three-thread	四线 Four-thread	五线 Five-thread
1	210529-9U	夹线器组件(红点)	Tension Spring Assembly	1	1	1
2	208447-UA	调压螺母	Knob	1	1	1
3	208448	调压止动套	Ratchet	1	1	1
4	208450-UA	调压止动盖	Cup	1	1	1
5	210319	夹线片	Tension Disc	2	2	2
6	208449	夹线片垫	Felt	1	1	1
7	5082A	夹线螺钉	Screw Stud	1	1	1
8	20137	调压簧	Spring	1	1	1
9	210531-9U	夹线器组件(蓝点)	Tension Spring Assembly	1	1	1
10	201086	调压簧(弱)	Spring	1	1	1
11	275000	过线板	Thread Guide	1	1	1
12	7019	螺钉M4 × 7.5	Screw	2	2	2
13	275001	过线板	Thread Guide	1	1	1
14	202849	前过线板	Tension Guide	3	4	4
15	4009-HC	螺钉C5 × 7.5	Screw	1	0	0
16	210530-9U	夹线器组件(黄点)	Tension Spring Assembly	0	1	1
17	210532-9U	夹线器组件(绿点)	Tension Spring Assembly	1	1	1

5-516(H) Series

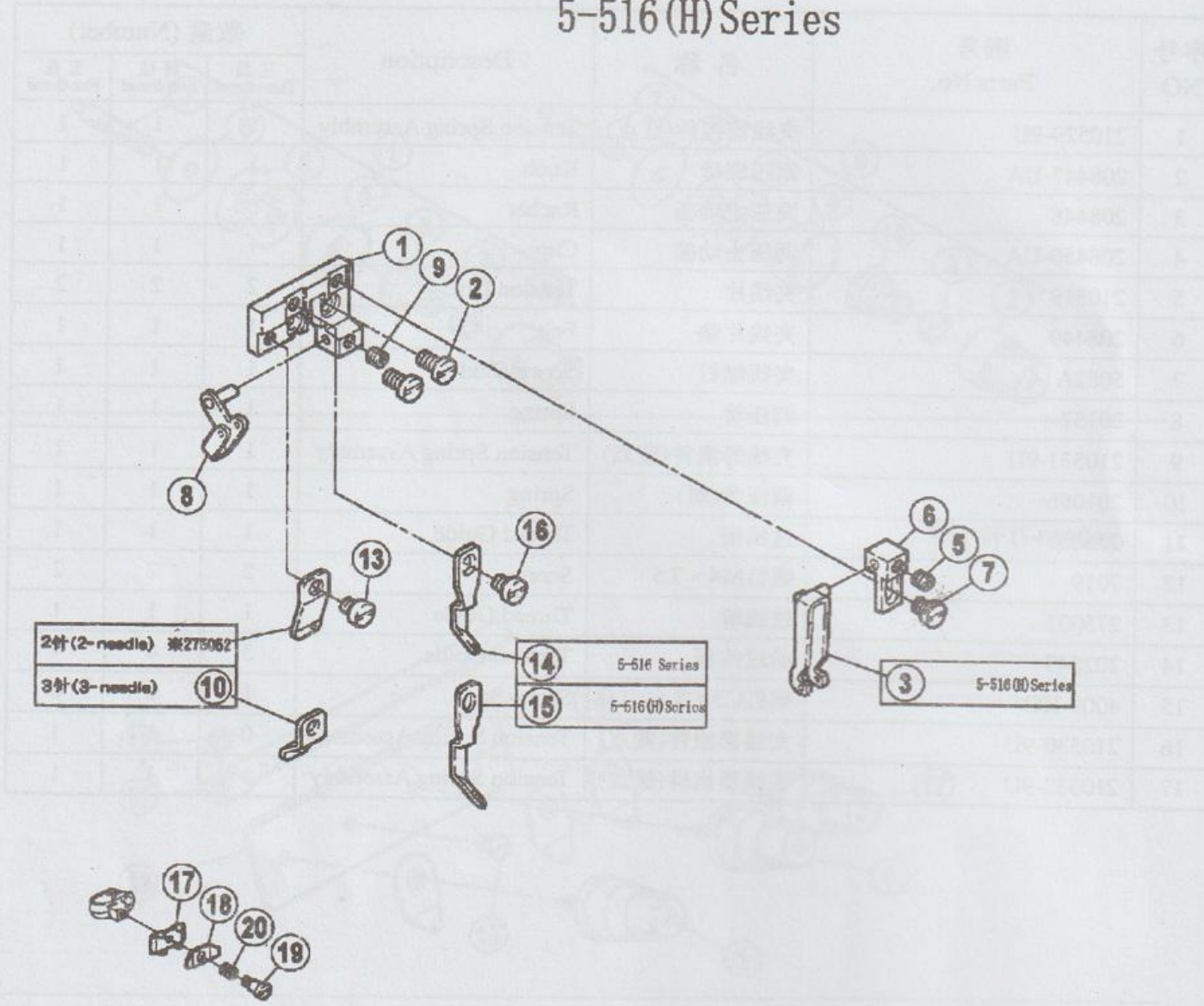

5-516 Series

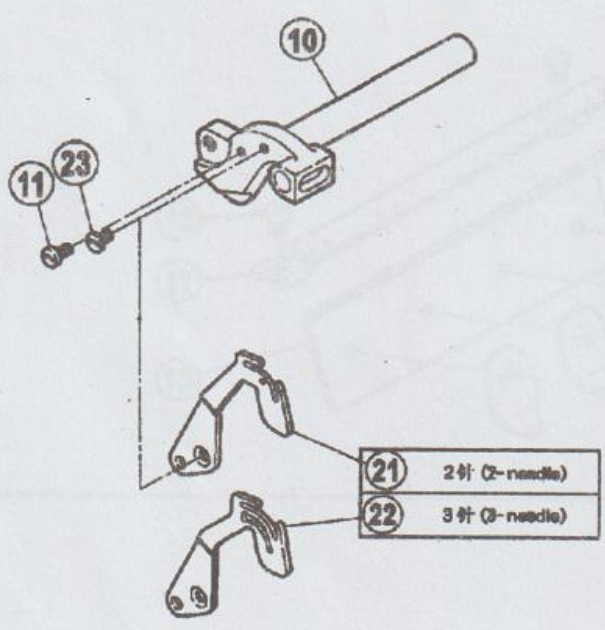

5-516(H) Series

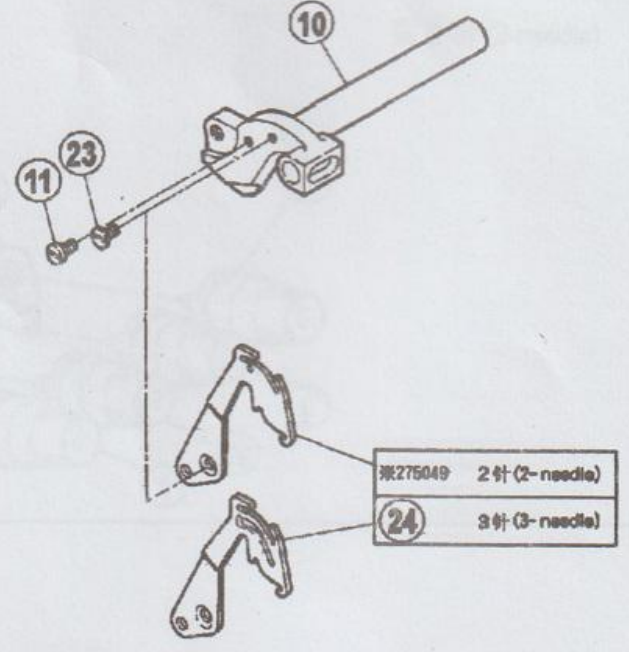

六、过线挑线器 Thread Guide and Thread Takeup (1)

序号 NO	图号 Parts No.	名称	Description	数量 (Number)		
				三线 Three-thread	四线 Four-thread	五线 Five-thread
1	275021	托架	Bracket	0	0	1
2	7082	螺钉M4 × 7.5	Screw	0	0	2
3	275024	过线	Thread Guide	0	0	1
4	275049	挑线杆	Thread Takeup	0	0	1
5	4543	螺钉M4 × 4	Screw	0	0	1
6	275026	托架	Bracket	0	0	1
7	7017	螺钉M4 × 4.7	Screw	0	0	1
8	275022	过线	Thread Guide	0	0	1
9	4543	螺钉M4 × 4	Screw	0	0	1
10	273004	上刀架轴	Upper Knife Lever	1	1	1
11	7062	螺钉M3 × 6	Screw	0	0	1
12	275052A	过线	Thread Guide	0	0	1
13	7017	螺钉M4 × 4.7	Screw	0	0	1
14	275028	过线	Thread Guide	0	0	1
15	275057	过线	Thread Guide	0	0	1
16	7017	螺钉M4 × 4.7	Screw	0	0	1
17	275011	托架	Bracket	0	0	1
18	275012	压线板	Thread Retainer	0	0	1
19	7163	螺钉	Screw	0	0	1
20	240326	压簧	Spring	0	0	1
21	275027A	挑线	Thread Takeup	0	0	1
22	275044A	挑线	Thread Takeup	0	0	1
23	7041	螺钉M3 × 5	Screw	1	1	1
24	275050	挑线	Thread Takeup	0	0	1

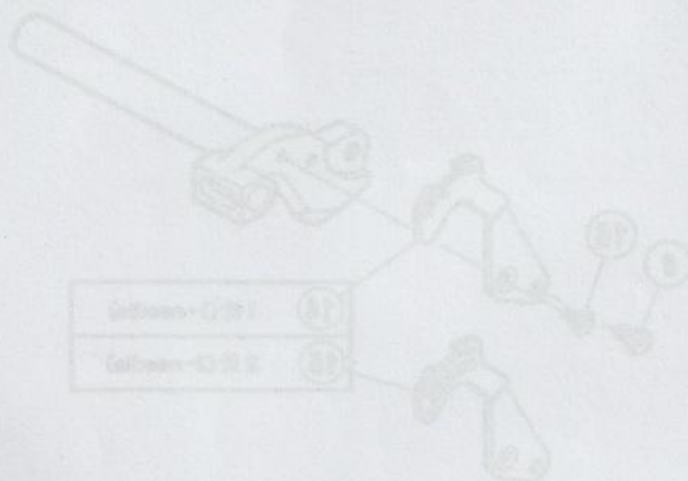

4-514(H) Series

Part No.	Part Name	QTY	Unit	Material	Notes
1	Bracket	1	PC	3-504 506Series	
2	Bracket	1	PC	4-514 Series	
3	Bracket	1	PC		
4	Bracket	1	PC		
5	Bracket	1	PC		
6	Bracket	1	PC		
7	Bracket	1	PC		
8	Bracket	1	PC		
9	Bracket	1	PC		
10	Bracket	1	PC		
11	Bracket	1	PC		
12	Bracket	1	PC		
13	Bracket	1	PC		
14	Bracket	1	PC		
15	Bracket	1	PC		
16	Bracket	1	PC		
17	Bracket	1	PC		
18	Bracket	1	PC		
19	Bracket	1	PC		
20	Bracket	1	PC		
21	Bracket	1	PC		
22	Bracket	1	PC		
23	Bracket	1	PC		
24	Bracket	1	PC		

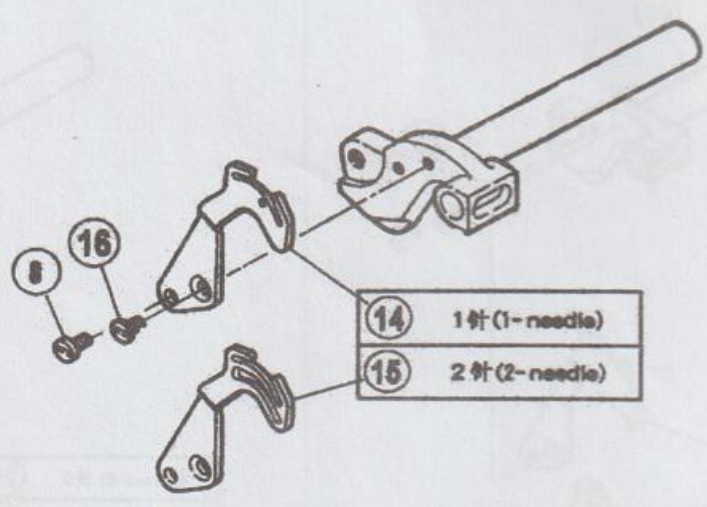
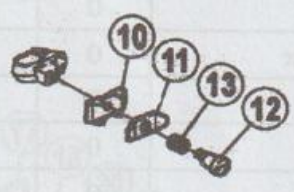
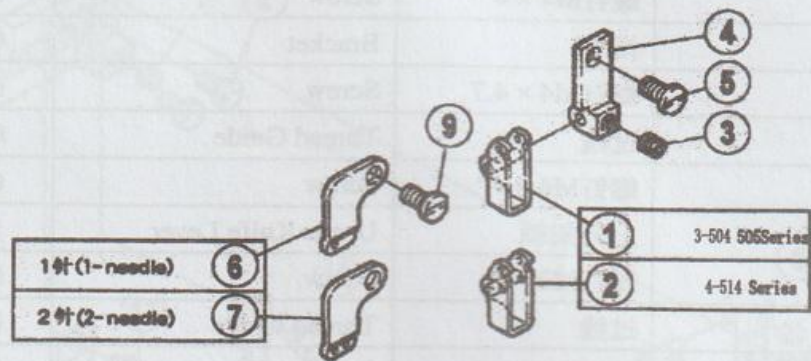

七、过线机构(2)/Thread Guide and Thread Takeup (2)

序号 NO	图号 Parts No.	名称	Description	数量 (Number)		
				三线 Three-thread	四线 Four-thread	五线 Five-thread
1	275013A	过线	Thread Guide	1	0	0
2	275013	过线	Thread Guide	0	1	0
3	4543	螺钉M4 × 4	Screw	1	1	0
4	275015	托架	Bracket	1	1	0
5	7082	螺钉M4 × 7.5	Screw	1	1	0
6	275051	过线	Thread Eyelet	1	0	0
7	275051A	过线	Thread Eyelet	0	1	0
8	7062	螺钉M3 × 6	Screw	1	1	0
9	7082	螺钉M4 × 7.5	Screw	1	1	0
10	275011	托架	Bracket	1	1	0
11	275012	压线板	Thread Retainer	1	1	0
12	7163	螺钉	Screw	1	1	0
13	240326	压簧	Spring	1	1	0
14	275016A	挑线	Thread Takeup	1	0	0
15	275017A	挑线	Thread Takeup	0	1	0
16	7041	螺钉M3 × 5	Screw	1	1	0

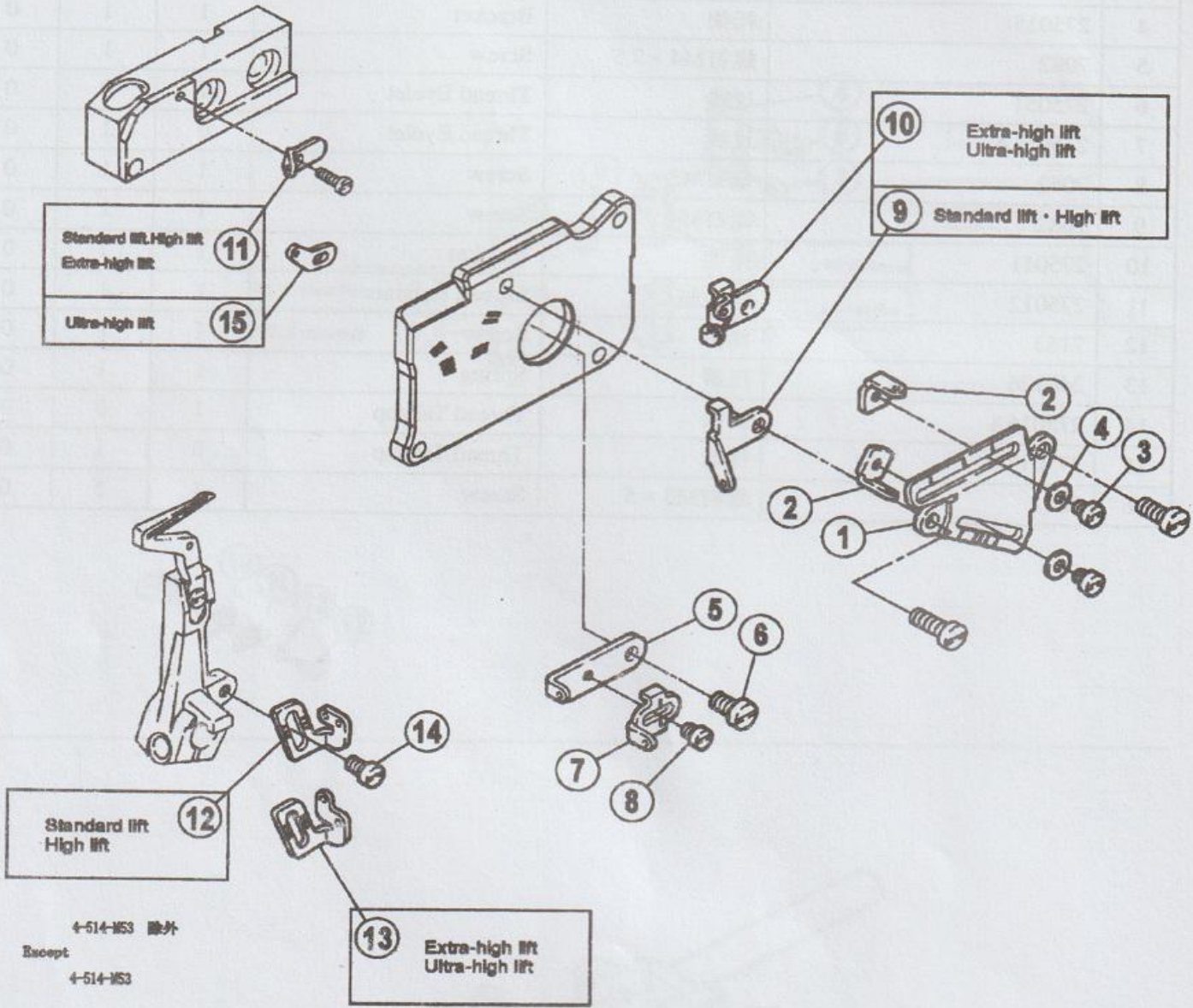

八、过线机构(3)/Thread Guide and Thread Takeup (3)

序号 NO	图号 Parts No.	名称	Description	数量 (Number)		
				三线 Three-thread	四线 Four-thread	五线 Five-thread
1	275004	托架	Bracket	1	1	1
2	275047	过线	Thread Guide	2	2	2
3	---	S014螺钉	Screw	2	2	2
4	---	垫圈	Washer	2	2	2
5	275005	挑线架	Thread Takeup	1	1	1
6	7019	螺钉M4 × 7.5	Screw	1	1	1
7	275006	过线	Thread Eyelet	1	1	1
8	7008	螺钉M3 × 4	Screw	1	1	1
9	275007	过线	Thread Guide	1	1	0
10	275055	过线	Thread Guide	0	0	1
11	275056	过线	Thread Guide	0	0	1
12	275009	挑线架	Thread Takeup	1	1	0
13	275054	挑线架	Thread Takeup	0	0	1
14	7012	螺钉M3.5 × 6	Screw	1	1	1
15	275010	过线	Thread Guide	1	1	1

4-514 Series

取量 (Number)		Description	Part No.	NO
取量 (Number)	取量 (Number)			
1	1	Bracket	27004	1
2	2	Thread Bolt	27004	2
3	2	Pin	201-4001	3
4	2	Washer	27004	4
5	1	Thread Bolt	27004	5
6	1	Washer	27004	6
7	1	Pin	27004	7
8	1	Thread Bolt	27004	8
9	1	Washer	27004	9
10	1	Thread Bolt	27004	10
11	1	Washer	27004	11
12	1	Thread Bolt	27004	12
13	1	Washer	27004	13
14	1	Thread Bolt	27004	14
15	1	Washer	27004	15
16	1	Pin	27004	16
17	1	Thread Bolt	27004	17
18	1	Washer	27004	18
19	1	Thread Bolt	27004	19
20	1	Washer	27004	20
21	1	Pin	27004	21
22	1	Thread Bolt	27004	22
23	1	Washer	27004	23
24	1	Pin	27004	24
25	1	Thread Bolt	27004	25
26	1	Washer	27004	26
27	1	Pin	27004	27
28	1	Thread Bolt	27004	28

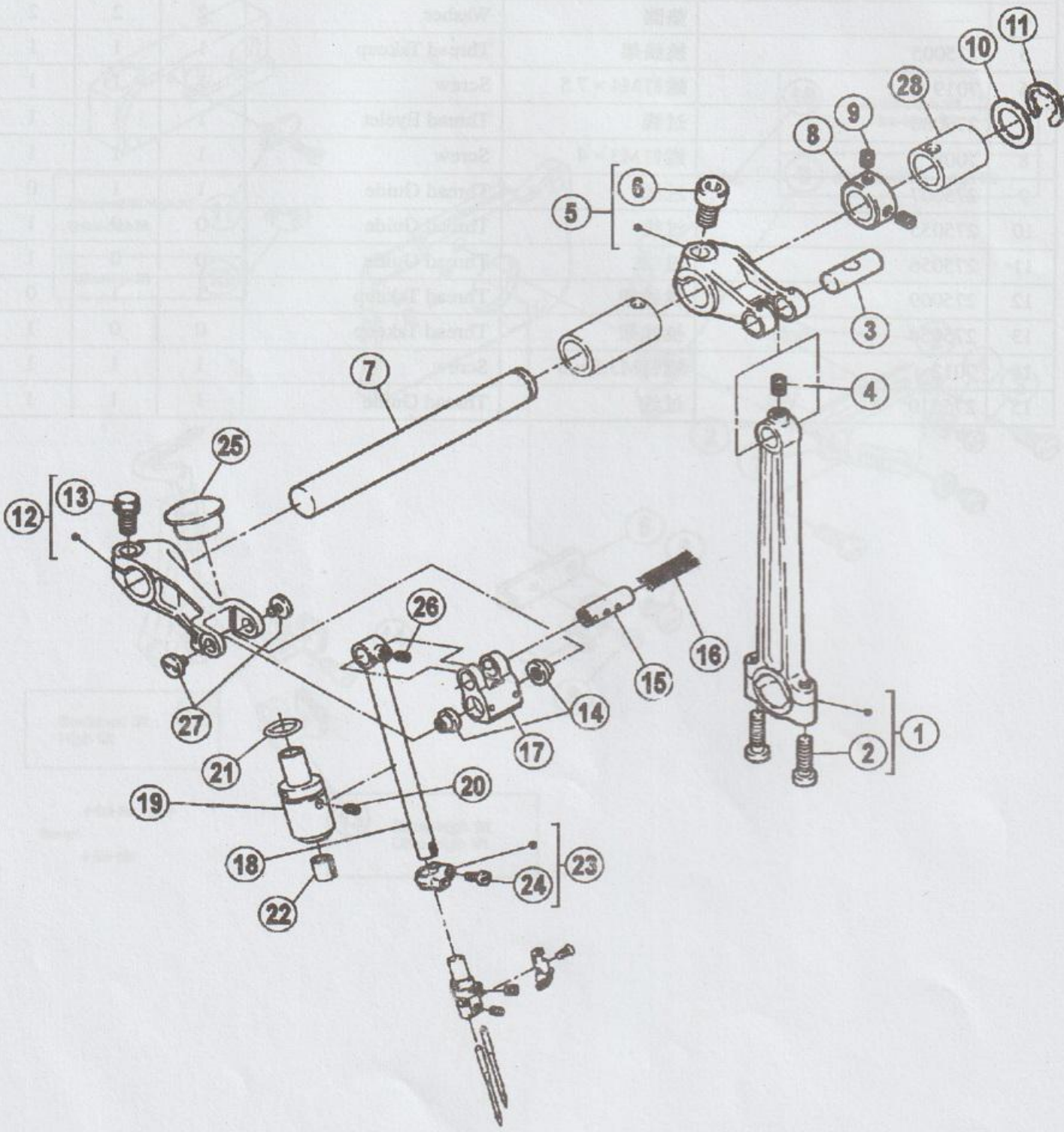

九、针杆部件(1)/Needle Drive Mechanism (1)

序号 NO	图号 Parts No.	名称	Description	数量 (Number)		
				三线 Three-thread	四线 Four-thread	五线 Five-thread
1	271000-92	针杆连杆	Connection	1	1	1
2	7023	螺钉M4 × 16	Screw	2	2	2
3	271001	曲柄销	Pin	1	1	1
4	4538	螺钉M4 × 6	Screw	1	1	1
5	271002-92	上轴曲柄	Crank	1	1	1
6	4533	螺钉M6X0.75X12	Screw	1	1	1
7	271003	上轴	Shaft	1	1	1
8	240308	上轴挡圈	Collar	1	1	1
9	4543	螺钉M4 × 4	Screw	2	2	2
10	208235	上刀架垫片	Washer	1	1	1
11	202577	挡圈8	Ring	1	1	1
12	271015-92	针杆曲柄组件	Lever	1	1	1
13	7150	螺钉	Screw	1	1	1
14	271017	曲柄销组件	Shaft Assembly	2	2	2
15	271021	曲柄销	Shaft	1	1	1
16	---	JK788油线	Oil wick	1	1	1
17	271016	针杆组件	Bushing Assembly	1	1	1
18	271019A	针杆	Needle Bar	1	1	1
19	271020	针杆套	Bushing	1	1	1
20	4546	螺钉M4 × 5	Screw	1	1	1
21	201022	O型圈11.5 × 1.5	O Ring	1	1	1
22	179009-05	毛毡	Oil Felt	1	1	1
23	271009-92	挡圈	Ring	1	1	1
24	7035	螺钉3 × 6	Screw	1	1	1
25	240310	油塞	Plug	1	1	1
26	45	螺钉	Screw	1	1	1
27	7185	螺钉M3 × 4	Screw	2	2	2
28	577601	轴套	Sleeve	1	1	1

5-516(H) Series

■ 2 针 (2-needle)

5-516

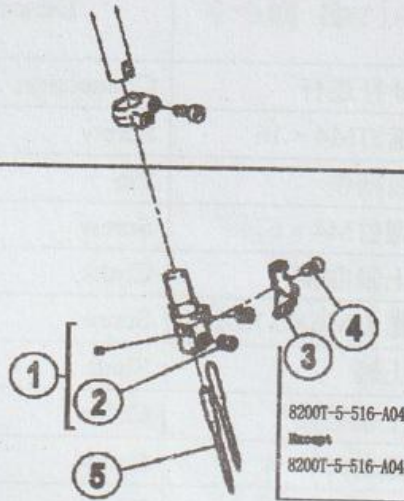

4-514 Series

■ 1 针 (1-needle)

3-504, 505

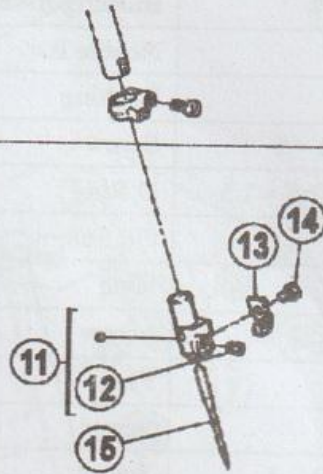

■ 2 针 (2-needle)

4-514

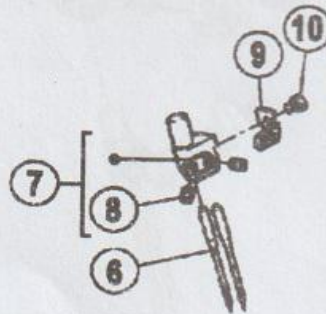

十一、针杆部件(3)/Needle Drive Mechanism (3)

序号 NO	图号 Parts No.	名称	Description	数量 (Number)		
				三线 Three-thread	四线 Four-thread	五线 Five-thread
1	XXXXXXXXXX	针夹头	Needle Holder Assembly	0	0	1
2	4554	螺钉M3 × 3	Screw	0	0	2
3	275030	过线	Thread Guide	0	0	1
4	7120	螺钉M2 × 3	Screw	0	0	1
5	XXXXXXXXXX	机针	Needle	0	0	2
6	XXXXXXXXXX	机针	Needle	0	2	0
7	XXXXXXXXXX	(四线)针夹头	Needle Holder	0	1	0
8	4554	螺钉M3 × 3	Screw	0	2	0
9	275019C	过线	Thread Guide	0	1	0
10	7120	螺钉M2 × 3	Screw	0	1	0
11	XXXXXXXXXX	(三线)针夹头	Needle Holder Assembly	1	0	0
12	4554	螺钉M3 × 3	Screw	1	0	0
13	275019A	过线(一针)	Thread Guide	1	0	0
14	7120	螺钉M2 × 3	Screw	1	0	0
15	XXXXXXXXXX	机针	Needle	1	0	0

5-516 (H) Series

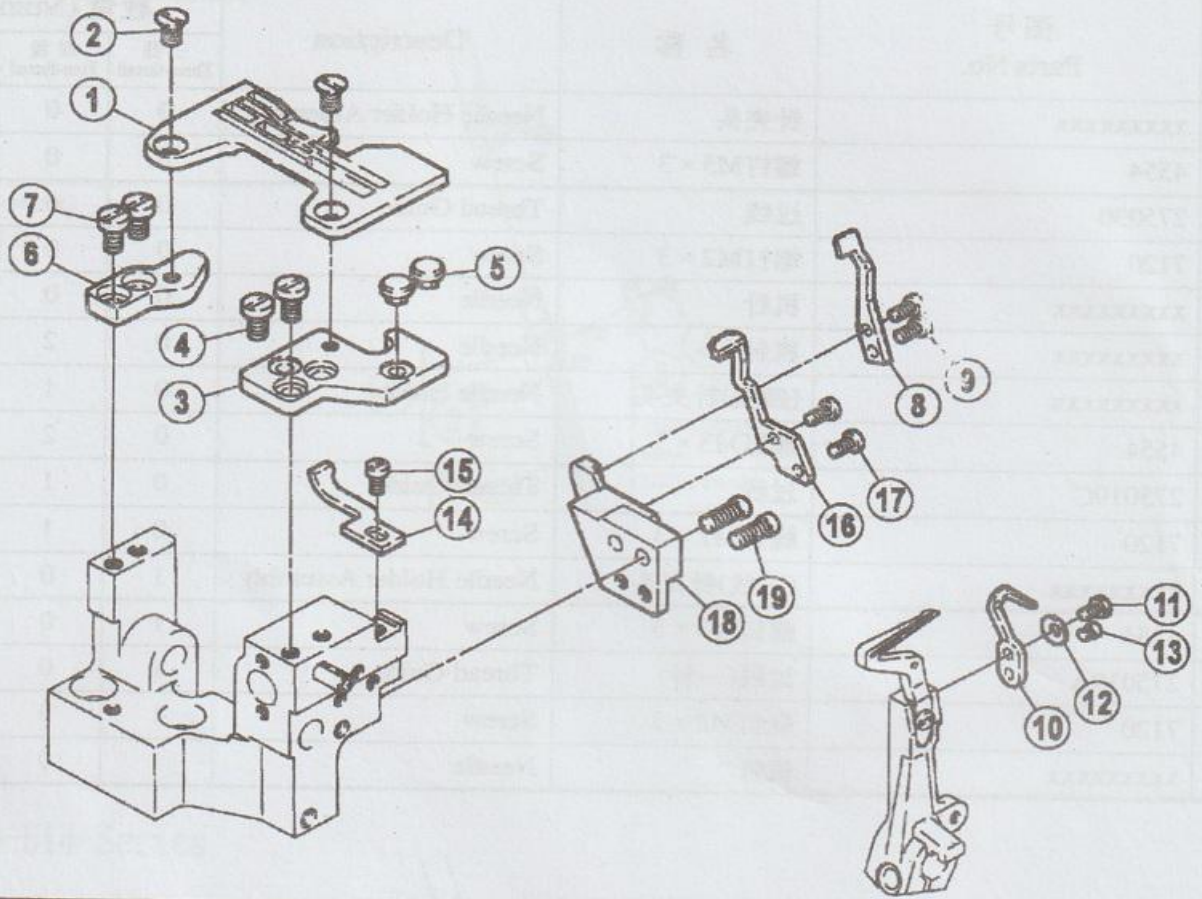

4-514 Series

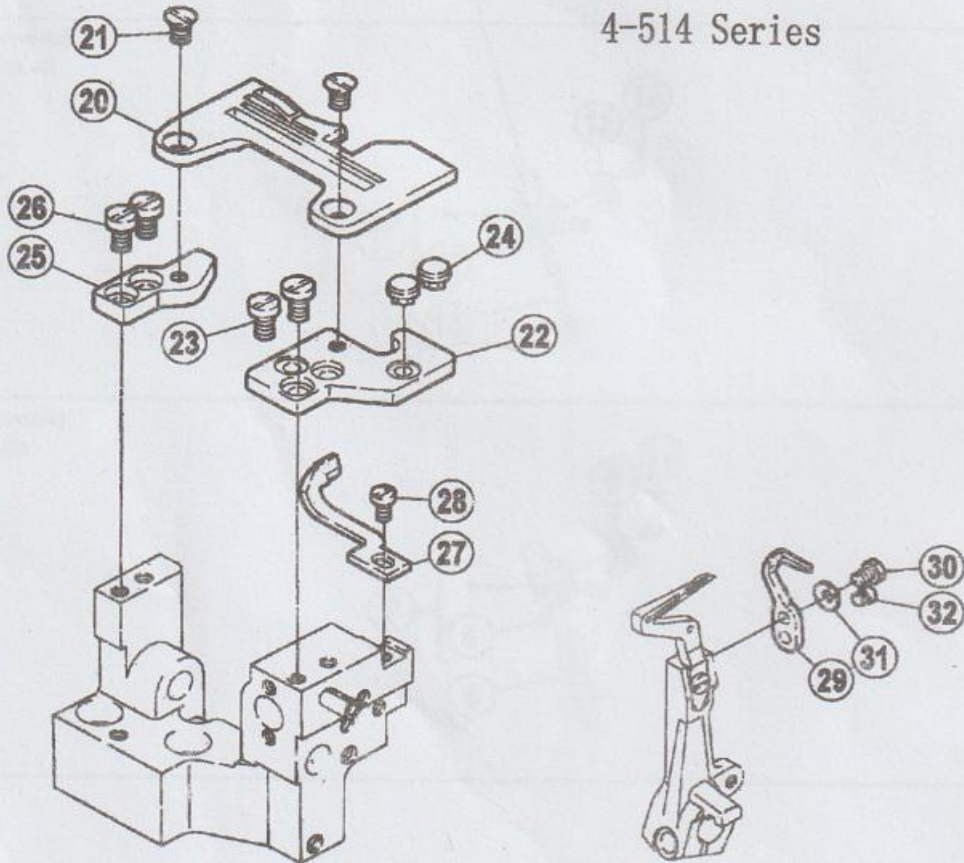

十二、针杆部件(4)/Needle Drive Mechanism (4)

序号 NO	图号 Parts No.	名称	Description	数量 (Number)		
				三线 Three-thread	四线 Four-thread	五线 Five-thread
1	XXXXXXXX	针板	Needle Plate	0	0	1
2	7170	螺钉M4 × 7.5	Screw	0	0	2
3	271010	针板垫块 (前)	Bracket	0	0	1
4	7019	螺钉M4 × 7.5	Screw	0	0	2
5	240305	防震垫	Cushion Rubber	0	0	2
6	271011	针板垫块 (后)	Bracket	0	0	1
7	7019	螺钉M4 × 7.5	Screw	0	0	2
8	XXXXXXXX	链弯针护针	Needle Guard	0	0	1
9	7010	螺钉M3 × 6	Screw	0	0	2
10	XXXXXXXX	护针 (后)	Needle Guard	0	0	1
11	7259	螺钉	Screw	0	0	1
12	240222	垫圈3	Spring	0	0	1
13	7165	螺丝M3	Screw	0	0	1
14	XXXXXXXX	机针护针 (前)	Needle Guard	0	0	1
15	7019	螺钉M4 × 7.5	Screw	0	0	1
16	XXXXXXXX	机针护针 (后)	Needle Guard	0	0	1
17	7010	螺钉M3 × 6	Screw	0	0	2
18	271013	托架	Bracket	0	0	1
19	7114	螺丝M4 × 10	Screw	0	0	2
20	XXXXXXXX	针板	Needle Plate	0	1	0
21	7170	螺钉M4 × 7.5	Screw	2	2	0
22	271010	针板垫块 (前)	Bracket	1	1	0
23	7019	螺钉M4 × 7.5	Screw	2	2	0
24	240305	减震垫	Cushion Rubber	2	2	0
25	271011	针板垫块 (后)	Bracket	1	1	0
26	7019	螺钉M4 × 7.5	Screw	2	2	0
27	XXXXXXXX	护针 (前)	Needle Guard	1	1	0
28	7019	螺钉M4 × 7.5	Screw	1	1	0
29	XXXXXXXX	护针 (后)	Needle Guard	1	1	0
30	7259	螺钉	Screw	1	1	0
31	240222	垫圈3	Spring	1	1	0
32	7165	螺钉M3	Screw	1	1	0

5-516(H) Series

4-514 Series

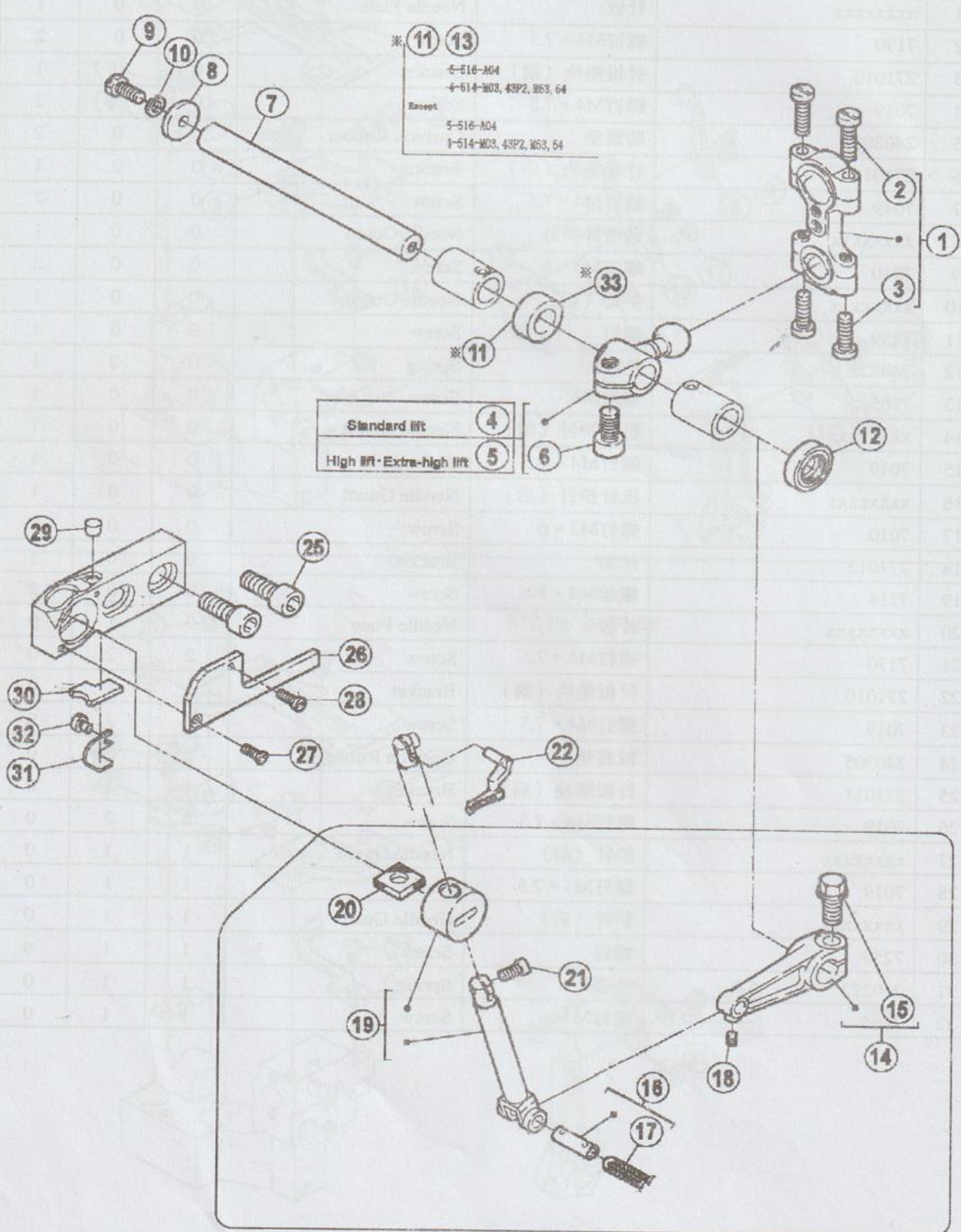

十三、上弯针部件/Upper Looper Drive Mechanism

序号 NO	图号 Parts No.	名称	Description	数量 (Number)		
				三线 Three-thread	四线 Four-thread	五线 Five-thread
1	271500-92	弯针连杆	Connection	1	1	1
2	7023	螺钉M4 × 16	Screw	2	2	2
3	7022	螺钉M4 × 17.5	Screw	2	2	2
4	271502-92	上弯针球曲柄	Crank	1	0	0
5	271503-92	上弯针球曲柄	Crank	0	1	1
6	4533	螺钉M6X0.75X12	Screw	1	1	1
7	271504	下弯针轴	Shaft	1	1	1
8	240338	垫圈	Washer	1	1	1
9	7174	螺钉M4 × 10	Screw	1	1	1
10	303067	上弯针垫圈	Spring Washer	1	1	1
11	210122	衬套	Spacer	0	1	0
12	210586A	油封	Oil Seal	1	1	1
13	210122A	衬套A	Spacer	1	0	1
14	271505-92	连杆	Lever	1	1	1
15	7150	螺钉	Screw	1	1	1
16	179137-05	曲柄销	Pin Assy.	1	1	1
17	----	JK788油线	Oil Wick	1	1	1
18	4545	螺钉M3 × 4	Screw	1	1	1
19	271517-91	上弯针滑杆组件	Upper Looper Holder Assy.	1	1	1
20	179130-05	上弯针滑杆套油毡	Felt	1	1	1
21	7054	螺钉M3.5 × 6.7	Screw	1	1	1
22	XXXXXXXX	上弯针	Upper Looper	1	1	1
23	----	----	----	----	----	----
24	----	----	----	----	----	----
25	4510	螺钉M6 × 16	Screw	2	2	2
26	271511	盖板	Cover	1	1	1
27	7039	螺钉M2.5 × 6	Screw	1	1	1
28	7033	螺钉M2.5 × 8	Screw	1	1	1
29	----	JK795油线	Oil Wick	1	1	1
30	2745890	吸油棉	Felt	1	1	1
31	2745880	压板	Bracket	1	1	1
32	7008	螺钉M3 × 4	Screw	1	1	1

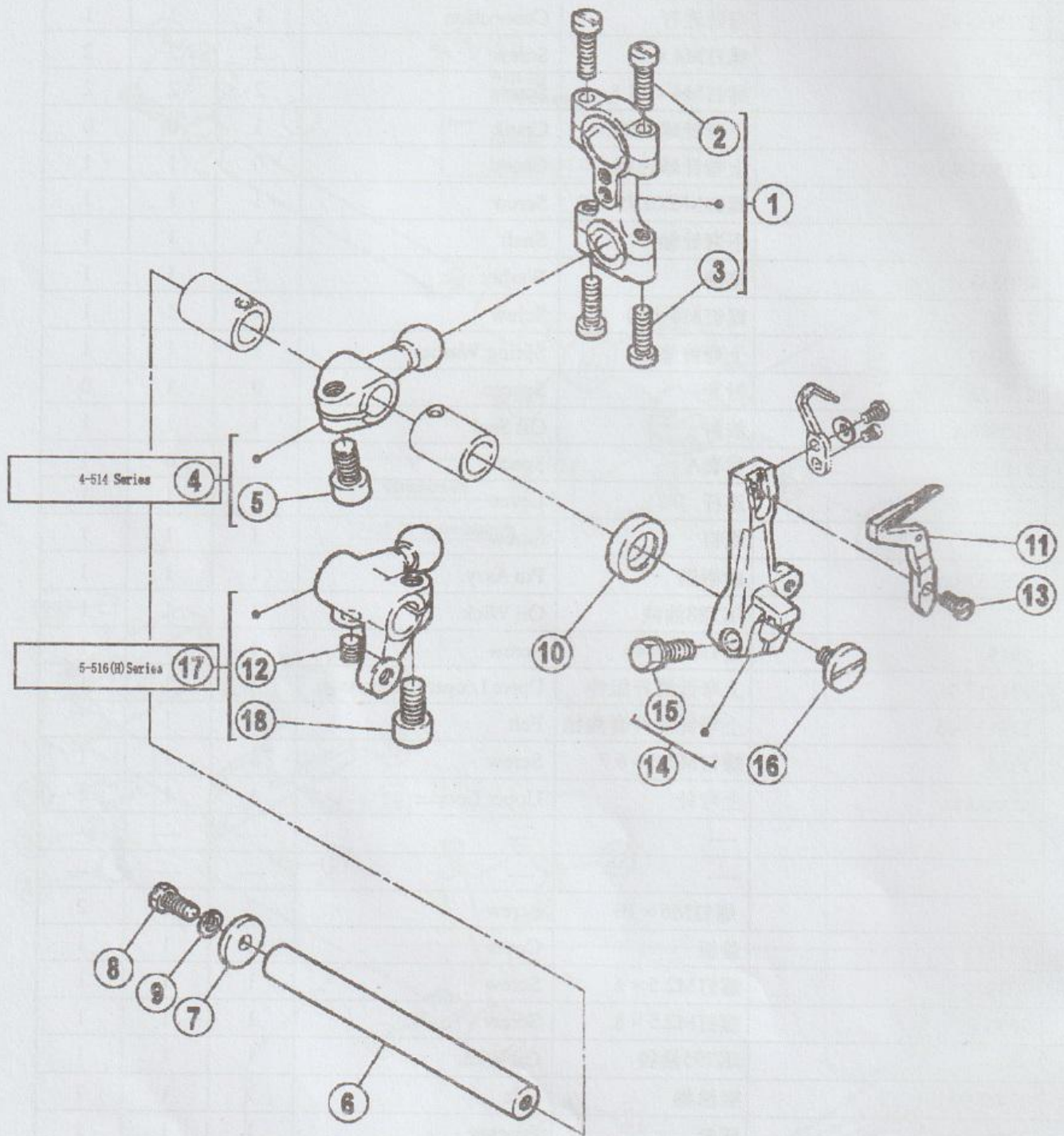

十五、下弯针部件/Lower Loper Drive Mechanism

序号 NO	图号 Parts No.	名称	Description	数量 (Number)		
				三线 Three-thread	四线 Four-thread	五线 Five-thread
1	271500-92	弯针连杆	Connection	1	1	1
2	7023	螺钉M4 × 16	Screw	2	2	2
3	7022	螺钉M4 × 17.5	Screw	2	2	2
4	27200-92	下弯针球曲柄	Crank	1	1	0
5	4533	螺钉M6X0.75X12	Screw	1	1	0
6	271504	下弯针轴	Shaft	1	1	1
7	240338	垫圈	Washer	1	1	1
8	7174	螺钉M4 × 10	Screw	1	1	1
9	303067	上弯针垫圈	Spring Washer	1	1	1
10	210586A	油封	Oil Seal	1	1	1
11	XXXXXXXX	下弯针	Lower Loper	1	1	1
12	4514	螺钉M5 × 5	Screw	0	0	1
13	7168	螺钉M3.5 × 6.5	Screw	1	1	1
14	272001-92	下弯针架	Lower Loper Holder	1	1	1
15	7055	螺钉M5 × 13	Screw	1	1	1
16	7169	螺钉M4 × 7	Screw	1	1	1
17	273511-92	下弯针球曲柄	Crank	0	0	1
18	4533	螺钉M6×0.75×12	Screw	0	0	1

数量 (Number)	名称 (Name)	规格 (Specification)	图号 (Drawing No.)
1	曲柄 (Crank)		5-516(H)-1
2	销 (Pin)		5-516(H)-2
3	销 (Pin)		5-516(H)-3
4	销 (Pin)		5-516(H)-4
5	销 (Pin)		5-516(H)-5
6	销 (Pin)		5-516(H)-6
7	销 (Pin)		5-516(H)-7
8	销 (Pin)		5-516(H)-8
9	销 (Pin)		5-516(H)-9
10	销 (Pin)		5-516(H)-10
11	销 (Pin)		5-516(H)-11
12	销 (Pin)		5-516(H)-12
13	销 (Pin)		5-516(H)-13
14	销 (Pin)		5-516(H)-14
15	销 (Pin)		5-516(H)-15
16	销 (Pin)		5-516(H)-16
17	销 (Pin)		5-516(H)-17
18	销 (Pin)		5-516(H)-18
19	销 (Pin)		5-516(H)-19
20	销 (Pin)		5-516(H)-20
21	销 (Pin)		5-516(H)-21
22	销 (Pin)		5-516(H)-22
23	销 (Pin)		5-516(H)-23
24	销 (Pin)		5-516(H)-24
25	销 (Pin)		5-516(H)-25
26	销 (Pin)		5-516(H)-26
27	销 (Pin)		5-516(H)-27
28	销 (Pin)		5-516(H)-28
29	销 (Pin)		5-516(H)-29

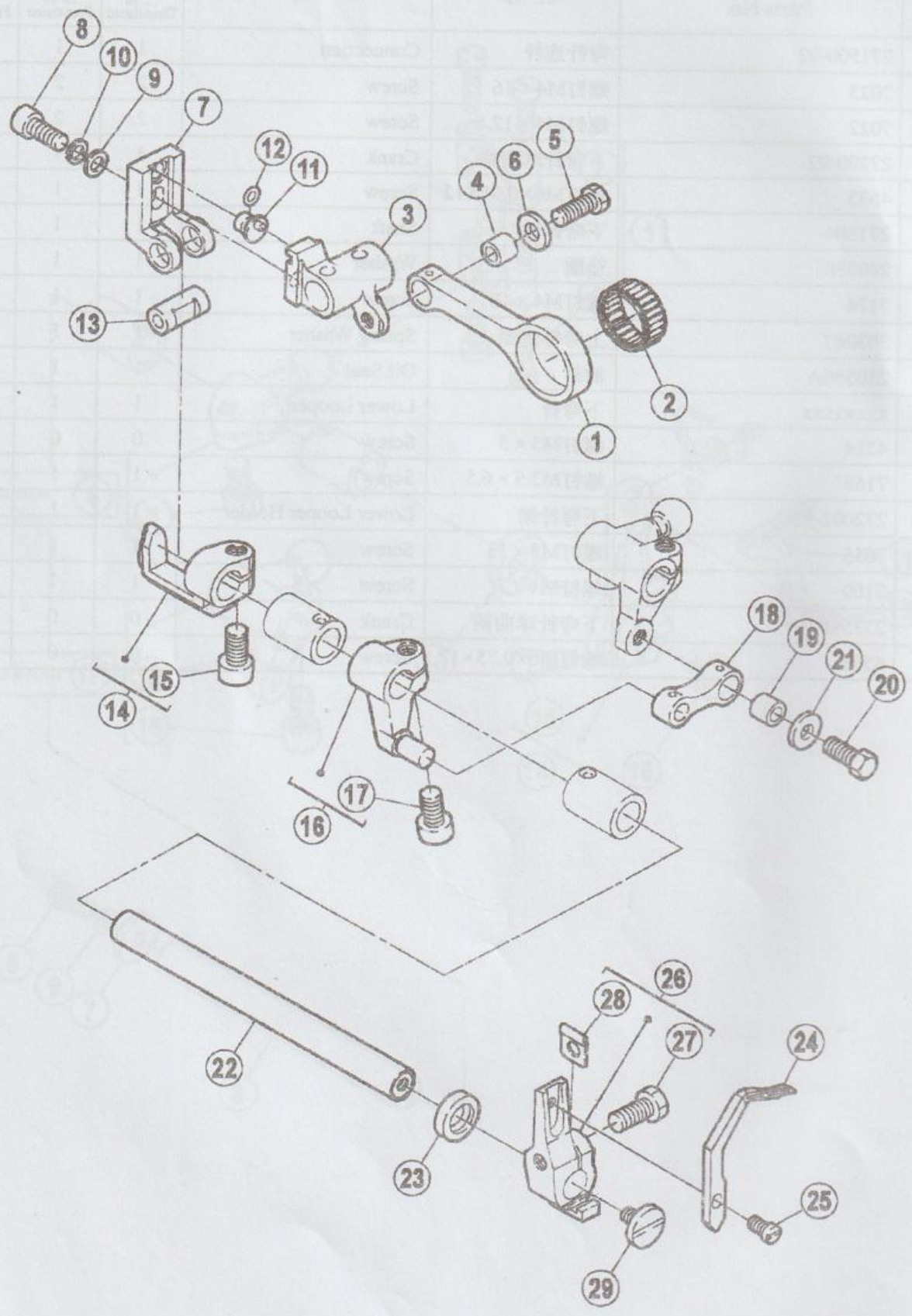

十六、二重环弯针机构(1)/Chainstitch Looper Drive Mechanism(1)

序号 NO	图号 Parts No.	名称	Description	数量 (Number)		
				三线 Three-thread	四线 Four-thread	五线 Five-thread
1	273500	连杆	Connection	0	0	1
2	205015	滚针k22 × 18 × 8	Needle Bearing	0	0	1
3	273501	曲柄	Crank	0	0	1
4	179160-05	连杆套	Bushing	0	0	1
5	7056	螺钉M5 × 13	Screw	0	0	1
6	204115	垫圈	Washer	0	0	1
7	273502	滑块座	Slider	0	0	1
8	4531	螺钉M5 × 12	Screw	0	0	1
9	240062	送布曲柄销垫圈	Washer	0	0	1
10	303067	上弯针垫圈	Spring Washer	0	0	1
11	252515	偏心销	Pin	0	0	1
12	208949	O形圈4 × 1.3	O Ring	0	0	1
13	273504	五线销	Shaft	0	0	1
14	273505-92	支架	Holder	0	0	1
15	4533	螺钉M6X0.75X12	Screw	0	0	1
16	273509-92	链线曲柄	Crank	0	0	1
17	4533	螺钉M6X0.75X12	Screw	0	0	1
18	272517	连杆	Link	0	0	1
19	179160-05	连杆套	Bushing	0	0	1
20	7056	螺钉M5 × 13	Screw	0	0	1
21	204115	垫圈	Washer	0	0	1
22	273506	链线轴	Shaft	0	0	1
23	204052A	油封	Oil Seal	0	0	1
24	xxxxxxxx	弯针	Double Chainstich Looper	1	1	1
25	7168	螺钉M3.5 × 6.5	Screw	0	0	1
26	273510-92	弯针架	Looper Holder	0	0	1
27	7055	螺钉M5 × 13	Screw	0	0	1
28	240337	垫片	Spacer	0	0	1
29	7169	螺钉M4 × 7	Screw	0	0	1

5-516(H) Series

Part No.	Description	QTY	Material	Remarks
1	Shaft	1	Steel	
2	Bracket	1	Steel	
3	Shaft	1	Steel	
4	Bracket	2	Steel	
5	Bracket	1	Steel	
6	Bracket	2	Steel	
7	Bracket	1	Steel	
8	Spring	1	Steel	
9	Roller	2	Steel	
10	Roller	2	Steel	
11	Roller	1	Steel	
12	Bracket	1	Steel	
13	Bracket	1	Steel	
14	Bracket	1	Steel	
15	Bracket	1	Steel	
16	Bracket	1	Steel	
17	Bracket	1	Steel	
18	Bracket	1	Steel	
19	Bracket	1	Steel	
20	Bracket	1	Steel	
21	Bracket	1	Steel	
22	Bracket	1	Steel	

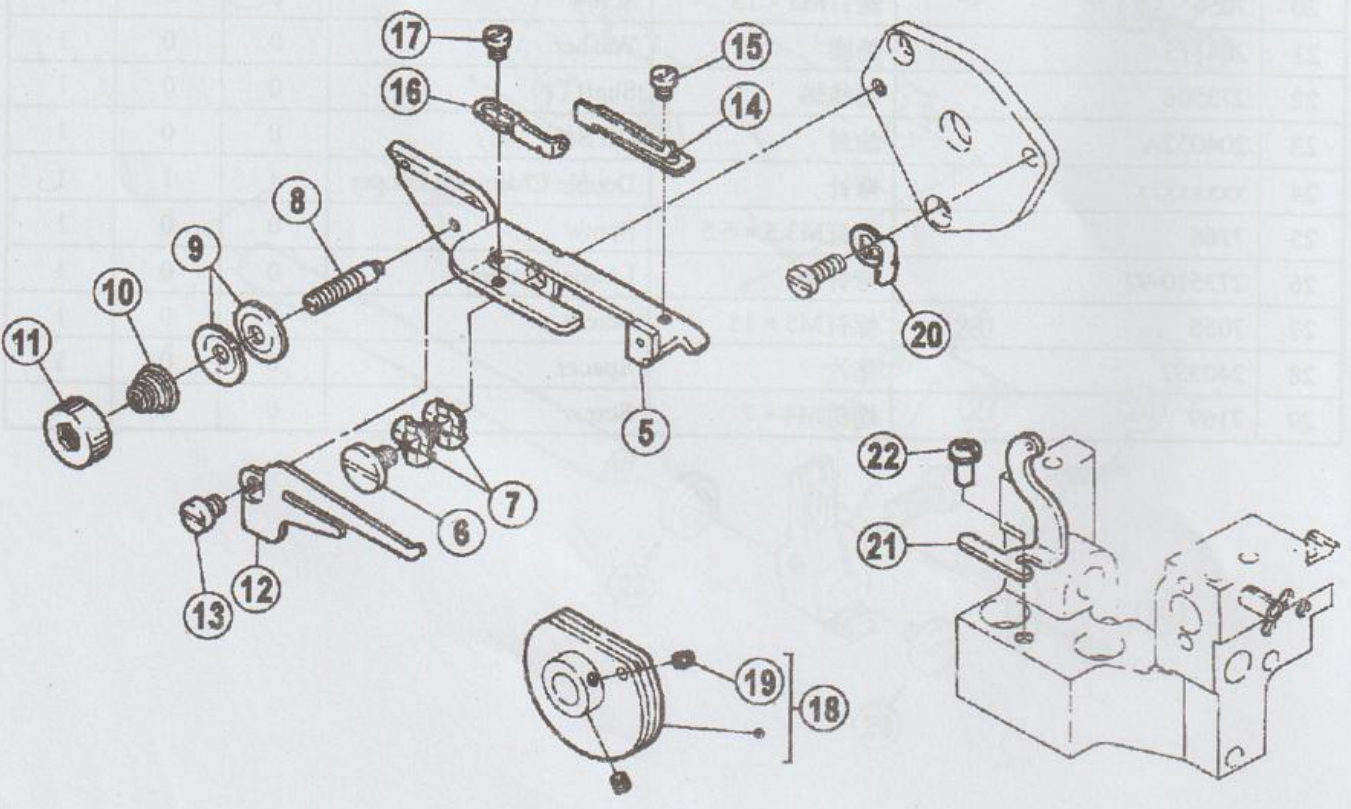
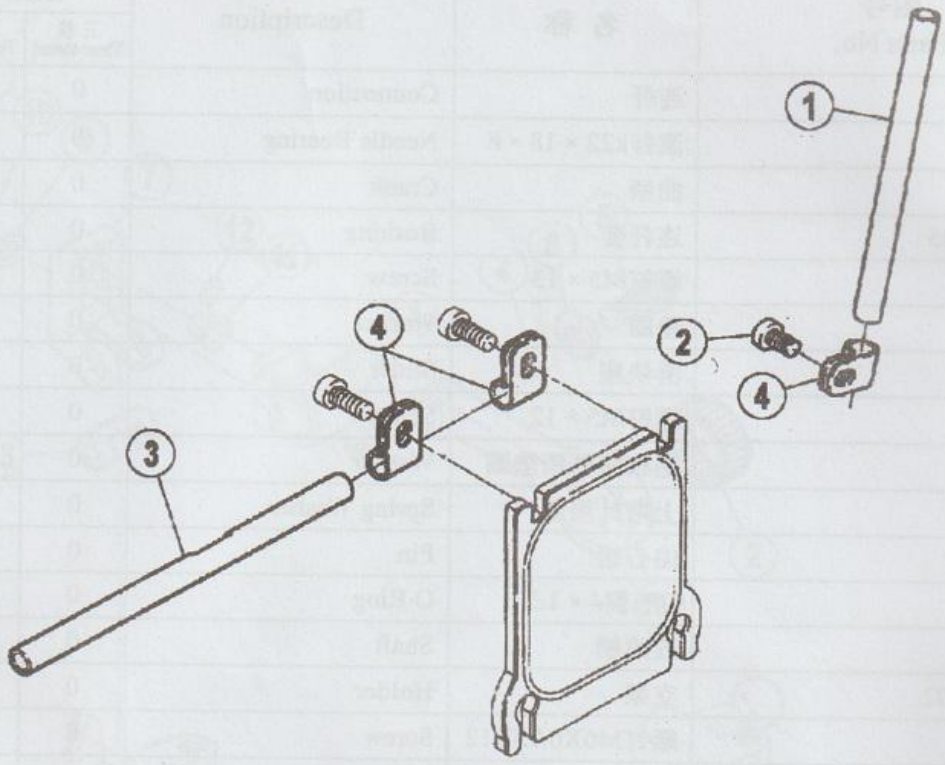

十七、二重环弯针机构(2)/Chainstitch Looper Drive Mechanism(2)

序号 NO	图号 Parts No.	名称	Description	数量 (Number)		
				三线 Three-thread	四线 Four-thread	五线 Five-thread
1	1921200	过线管	Thread Guide	0	0	1
2	7019	螺钉M4 × 7.5	Screw	0	0	1
3	275032	过线管	Thread Guide	0	0	1
4	206115	过线管夹	Holder	0	0	3
5	275033	打线凸轮架	Bracket	0	0	1
6	7066	螺钉M4	Screw	0	0	1
7	210307	垫圈	Washer	0	0	1
8	7167	螺丝M3	Screw	0	0	1
9	137108	夹线片	Tension Disc	0	0	2
10	211388	弹簧	Spring	0	0	1
11	275034	紧线手柄	Knob	0	0	1
12	275035	分线板	Thread Guide	0	0	1
13	7017	螺钉M4 × 4.7	Screw	0	0	1
14	275036	过线	Thread Guide	0	0	1
15	7008	螺钉M3 × 4	Screw	0	0	1
16	275039	过线	Thread Guide	0	0	1
17	7008	螺钉M3 × 4	Screw	0	0	1
18	179498-92	打线凸轮	Looper Thread Takeup	0	0	1
19	4554	螺钉M3 × 3	Screw	0	0	2
20	275037	卡簧	Spring	0	0	1
21	275038	过线	Thread Guide	0	0	1
22	7019	螺钉M4 × 7.5	Screw	0	0	1

零件号 (Part No.)	名称 (Name)	数量 (Qty)	备注 (Remarks)
1		1	
2		1	
3		1	
4		1	
5		1	
6		1	
7		1	
8		1	
9		1	
10		1	
11		1	
12		1	
13		1	
14		1	
15		1	
16		1	
17		1	
18		1	
19		1	
20		1	
21		1	
22		1	
23		1	
24		1	
25		1	
26		1	
27		1	
28		1	
29		1	
30		1	
31		1	
32		1	
33		1	
34		1	
35		1	
36		1	
37		1	
38		1	
39		1	
40		1	
41		1	
42		1	
43		1	
44		1	

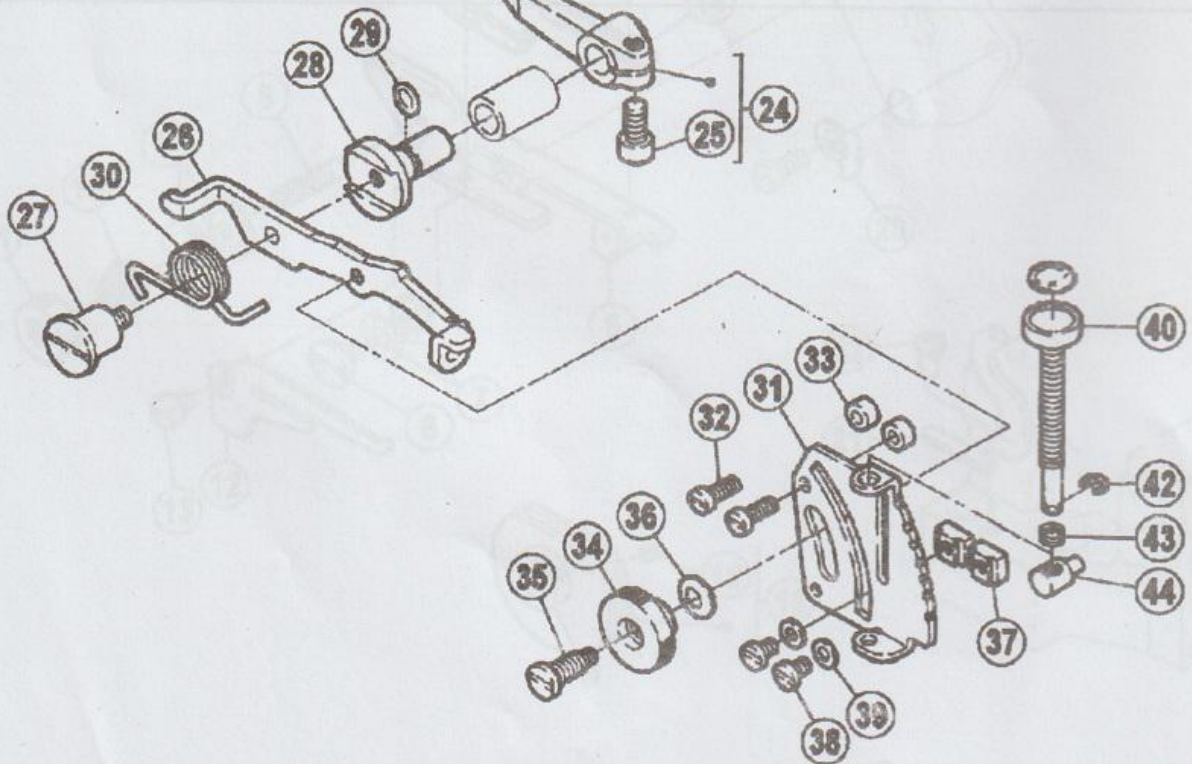

十八、差动调节机构/Feed Mechanism

序号 NO	图号 Parts No.	名称	Description	数量 (Number)		
				三线 Three-thread	四线 Four-thread	五线 Five-thread
1	272500	送料连杆	Connection	1	1	1
2	271001	曲柄销	Pin	1	1	1
3	4538	螺钉M4 × 6	Screw	1	1	1
4	240012	滚针轴承26 × 22 × 10	Needle Bearing	1	1	1
5	272501	偏心轮	Eccent	1	1	1
6	210129	小偏心轮	Feed Eccent	1	1	1
7	210130	弹簧板	Flat Spring	1	1	1
8	4535	螺钉M3 × 4	Screw	2	2	2
9	272506-91	送布偏心	Regulator	1	1	1
10	4514	螺钉M5 × 5	Screw	2	2	2
11	272504-91	开针偏心凸轮	Eccent Assembly	1	1	1
12	272503	弹簧	Spring	1	1	1
13	7038	螺钉M2	Screw	1	1	1
14	272502	滑块	Ratchet	1	1	1
15	272509	开针掀扭轴	Push Button	1	1	1
16	240315	油封	Gaket	1	1	1
17	208949	O形圈4 × 1.3	O Ring	1	1	1
18	240314	垫片	Washer	1	1	1
19	240317	弹簧	Spring	1	1	1
20	200555	卡簧3.5	Ring	1	1	1
21	272529	差动连片	Link	1	1	1
22	7058	螺钉M5 × 5	Screw	1	1	1
23	202522	卡簧	Ring	1	1	1
24	272530A92	差动曲柄	Lever	1	1	1
25	4533	螺钉M6 × 0.75 × 12	Screw	1	1	1
26	272532	差动杆	Lever	1	1	1
27	7161	螺钉	Screw	1	1	1
28	272533A	差动轴	Shaft	1	1	1
29	204185	差动轴O型圈	O Ring	1	1	1
30	272534	差动扳手定位簧	Spring	1	1	1
31	272535	调节板	Regulator Plate	1	1	1
32	7021	螺钉M4 × 12	Screw	2	2	2
33	240321	垫圈	Spacer	2	2	2
34	179202-25	调节螺母	Nut	1	1	1
35	179202-25-02	螺钉	Screw	1	1	1
36	7059	蝶形垫片	Spring Washer	1	1	1
37	211301	螺母	Stopper	2	2	2
38	252658	螺钉M4 × 5	Screw	2	2	2
39	7018	垫片	Washer	2	2	2
40	303448	调节杆	Adjusting Bar	1	1	1
41	272538A	标签	Seal	1	1	1
42	240322	卡簧3.5	Ring	1	1	1
43	210533	弹簧	Spring	1	1	1
44	272539A	螺母	Pin	1	1	1

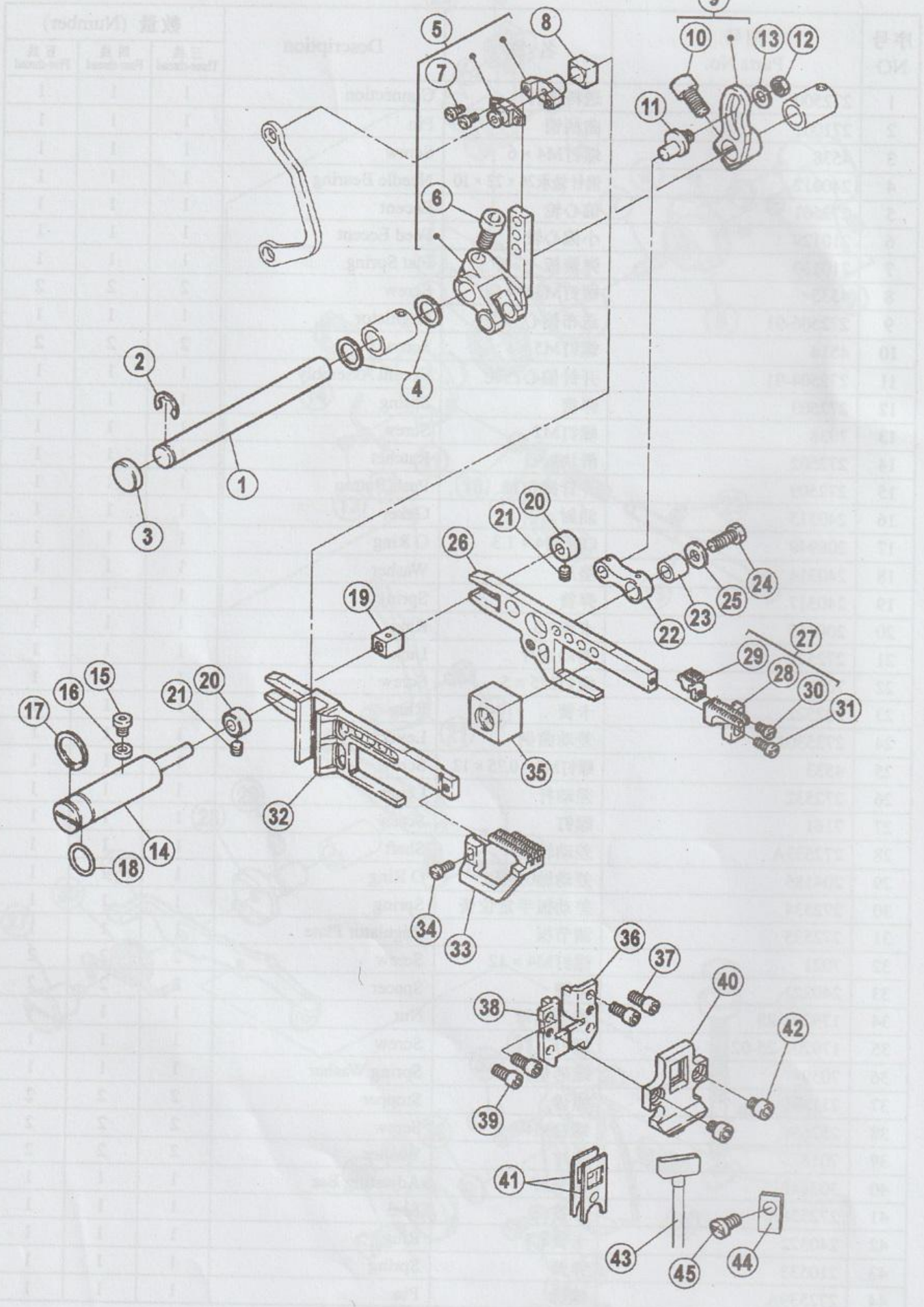

数量 (Number)		Description	件号 NO.
数量	件号		
1	1		1
1	1		2
1	1		3
1	1		4
1	1		5
1	1		6
1	1		7
1	1		8
1	1		9
1	1		10
1	1		11
1	1		12
1	1		13
1	1		14
1	1		15
1	1		16
1	1		17
1	1		18
1	1		19
1	1		20
1	1		21
1	1		22
1	1		23
1	1		24
1	1		25
1	1		26
1	1		27
1	1		28
1	1		29
1	1		30
1	1		31
1	1		32
1	1		33
1	1		34
1	1		35
1	1		36
1	1		37
1	1		38
1	1		39
1	1		40
1	1		41
1	1		42
1	1		43
1	1		44
1	1		45

十九、送布机构/Feed Mechanism

序号 NO	图号 Parts No.	名称	Description	数量 (Number)		
				三线 Three-thread	四线 Four-thread	五线 Five-thread
1	272516	送布轴	Shaft	1	1	1
2	205061	开口挡圈7	Ring	1	1	1
3	208173	送布轴油封	Plug	1	1	1
4	240311	送料轴垫圈	Washer	2	2	2
5	272510-91	送料曲柄组件	Crank	1	1	1
6	4534	螺钉M6×14	Screw	1	1	1
7	7010	螺钉M3×6	Screw	2	2	2
8	272518	滑块	Block	1	1	1
9	272514-92	送料曲柄	Crank	1	1	1
10	4533	螺钉M6X0.75X12	Screw	1	1	1
11	272515	偏心销	Pin	1	1	1
12	4805	螺母M5	Nut	1	1	1
13	240062	送布曲柄销垫圈	Wsher	1	1	1
14	272525	偏心轴	Pin	1	1	1
15	7238	螺钉	Screw	1	1	1
16	240318	O形圈	Gsket	1	1	1
17	240319	卡簧	Ring	1	1	1
18	201022	O型圈11.5×1.5	O Ring	1	1	1
19	272526	滑柱	Block	1	1	1
20	240303	挡圈	Collar	2	2	2
21	4543	螺钉M4×4	Screw	2	2	2
22	272517	连杆	Link	1	1	1
23	179160-05	连杆套	Bushing	1	1	1
24	7056	螺钉M5×13	Screw	1	1	1
25	204115	垫圈	Wsher	1	1	1
26	----	牙架组件	Main Feed Bar	1	1	1
27	xxxxxxxx	(三、四线)牙齿组件	Main Feed Dog Complete	1	1	1
28	xxxxxxxx	主送齿	Main Feed Dog	1	1	1
29	xxxxxxxx	辅助齿	Auxiliary	1	1	1
30	7010	螺钉M3X6	Screw	1	1	1
31	7013	螺钉M3.5×7.5	Screw	1	1	1
32	272528	差动齿牙架	Differential Feed Bar	1	1	1
33	xxxxxxxx	差动齿	Differential Feed Dog	1	1	1
34	7013	螺钉M3.5×7.5	Screw	1	1	1
35	272524	滑块	Block	1	1	1
36	272519	牙架挡块(左)	Feed Bar	1	1	1
37	7110	螺钉M4×9	Screw	2	2	2
38	272520	牙架挡块(右)	Feed Bar	1	1	1
39	7110	螺钉M4×9	Screw	2	2	2
40	272522	挡油板	Feed Bar Oil Seal	1	1	1
41	272521	牙架油封	Oil Seal	2	2	2
42	4573	螺钉M4×5	Screw	2	2	2
43	----	牙架吸油管	Tube	1	1	1
44	----	油管夹	Clamp	1	1	0
45	7018	螺钉M4×5	Screw	1	1	1

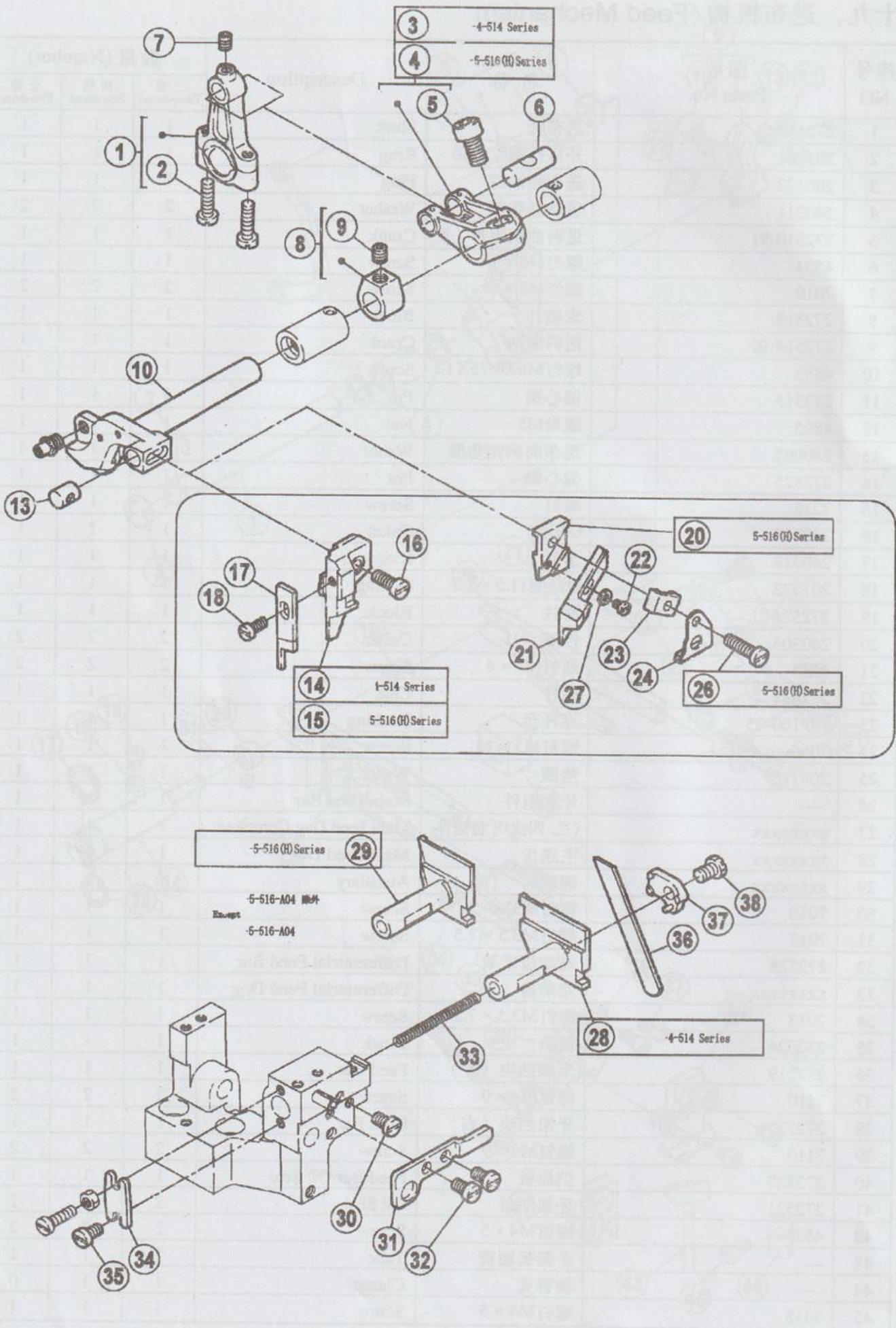

二十、剪布机构/Knife Drive Mechanism

序号 NO	图号 Parts No.	名称	Description	数量 (Number)		
				三线 Three-thread	四线 Four-thread	五线 Five-thread
1	273000-92	上刀连杆	Connection	1	1	1
2	7023	螺钉M4×.16	Screw	2	2	2
3	273001-92	上刀曲柄	Crank	1	1	0
4	3002-92	上刀曲柄	Crank	0	0	1
5	4533	螺钉M6×0.75×12	Screw	1	1	1
6	271001	曲柄销	Pin	1	1	1
7	4538	螺钉M4×6	Screw	1	1	1
8	240235-92	挡块	Collar	1	1	1
9	4547	螺钉M6×0.75×5	Screw	1	1	1
10	273003	上刀架轴	Upper Knife Lever	1	1	1
11	----	----	----	----	----	----
12	----	----	----	----	----	----
13	273006	导向销	Pin	1	1	1
14	179712-05	上刀座	Upper Knife Clamp	1	1	0
15	179713-05	上刀座	Upper Knife Clamp	0	0	1
16	7020	螺钉M4×10	Screw	1	1	1
17	xxxxxxxx	上刀	Upper Knife	1	1	1
18	7013	螺钉M3.5×7.5	Screw	1	1	1
19	210757	绞刀安装板	Angled Upper Knife Clamp	0	0	1
21	xxxxxxxx	切刀	Angled Upper	0	0	1
22	7008	螺钉M3×4	Screw	0	0	1
23	210758	上刀凹角切	Angled Upper Knife Gib	0	0	1
24	179341-15	挡板	Waste Guard	0	0	1
25	----	----	----	----	----	----
26	----	螺钉 M4×20	Screw	0	0	1
27	----	垫圈	Washer	0	0	1
28	273008	下刀架	Lower Knife Holder	1	1	0
29	273009	下刀架	Lower Knife Holder	0	0	1
30	7019	螺钉M4×7.5	Screw	1	1	1
31	273010	挡板	Lower Knife Holder Guard	1	1	1
32	7082	螺钉M4×7.5	Screw	2	2	2
33	240324	弹簧	Spring	1	1	1
34	273007	挡板	Plate	1	1	1
35	7019	螺钉M4×7.5	Screw	1	1	1
36	xxxxxxxx	下刀	Lower Knife	1	1	1
37	273012	压板	Lower Knife Clamp	1	1	1
38	7173	螺钉M5×8	Screw	1	1	1

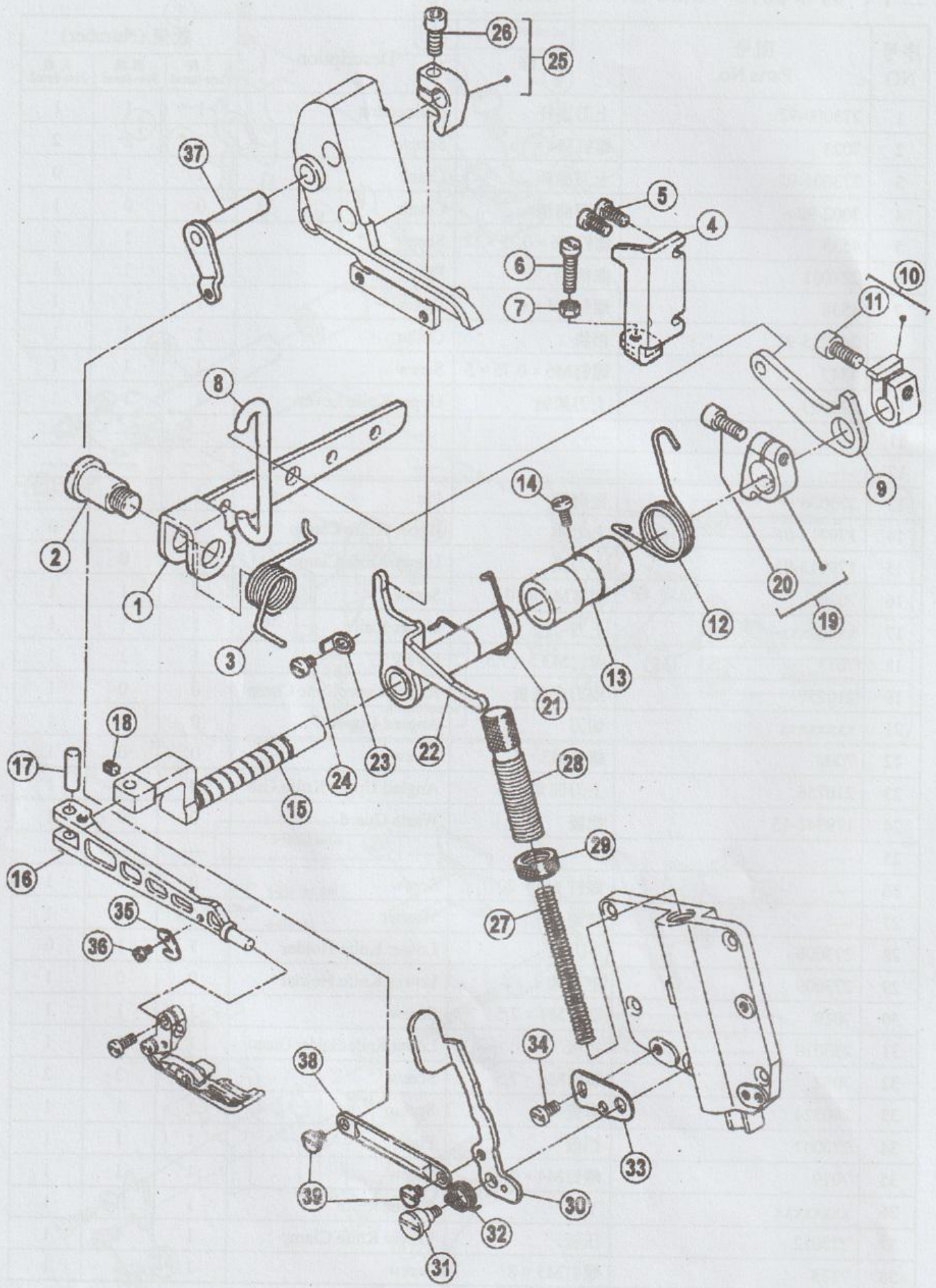

二十一、抬压脚机构/Presser Foot Mechanism

序号 NO	图号 Parts No.	名称	Description	数量 (Number)		
				三线 Three-thread	四线 Four-thread	五线 Five-thread
1	274007	抬压脚杠杆	Lever	1	1	1
2	7060	抬压脚螺钉M10	Screw	1	1	1
3	274008	扭簧	Spring	1	1	1
4	274009	角板	Stopper	1	1	1
5	7020	螺钉M4 × 10	Screw	2	2	2
6	7175	螺钉M4 × 24	Screw	1	1	1
7	4805	螺母M5	Nut	1	1	1
8	274006	弯钩	Link	1	1	1
9	274004	抬压脚小杠杆	Lever	1	1	1
10	274003-92	抬压脚复位圈	Collar	1	1	1
11	4534	螺钉M6 × 0.75 × 13.5	Screw	1	1	1
12	274043	弹簧	Spring	1	1	1
13	274044	轴套	Bushing	1	1	1
14	7023	螺钉M4 × 16	Screw	1	1	1
15	274001A	压脚轴	Shaft	1	1	1
16	274000-B	压脚臂	Presser Arm	1	1	1
17	208549	压脚臂连杆销	Pin	1	1	1
18	4594	螺钉M4 × 0.5 × 4	Screw	1	1	1
19	274042-92	挡圈	Collar	1	1	1
20	4541	螺钉M5 × 12	Screw	1	1	1
21	274055	弹簧	Spring	1	1	1
22	274045-91	抬牙杠杆组件	Lever	1	1	1
23	274054	压板	Stopper	1	1	1
24	7018	螺钉M4 × 6	Screw	1	1	1
25	223218A92	杠杆	Lever	1	1	1
26	4531	螺钉M5 × 12	Screw	1	1	1
27	208773A	压簧	Spring	1	1	1
28	274014	调节螺柱	Adjusting Screw	1	1	1
29	274015	螺母	Nut	1	1	1
30	274039	压杆扳手	Lever	1	1	1
31	7171	螺钉	Screw	1	1	1
32	274017	压杆扳手扭簧	Spring	1	1	1
33	274040	调节板	Stopper	1	1	1
34	7019	螺钉M4 × 7.5	Screw	1	1	1
35	202451	割线刀	Chain Cutter	1	1	1
36	7008	螺钉M3 × 4	Screw	1	1	1
37	274048-91	连杆	Lever	1	1	1
38	274041	连接板	Link	1	1	1
39	7193	螺钉	Screw	1	1	1

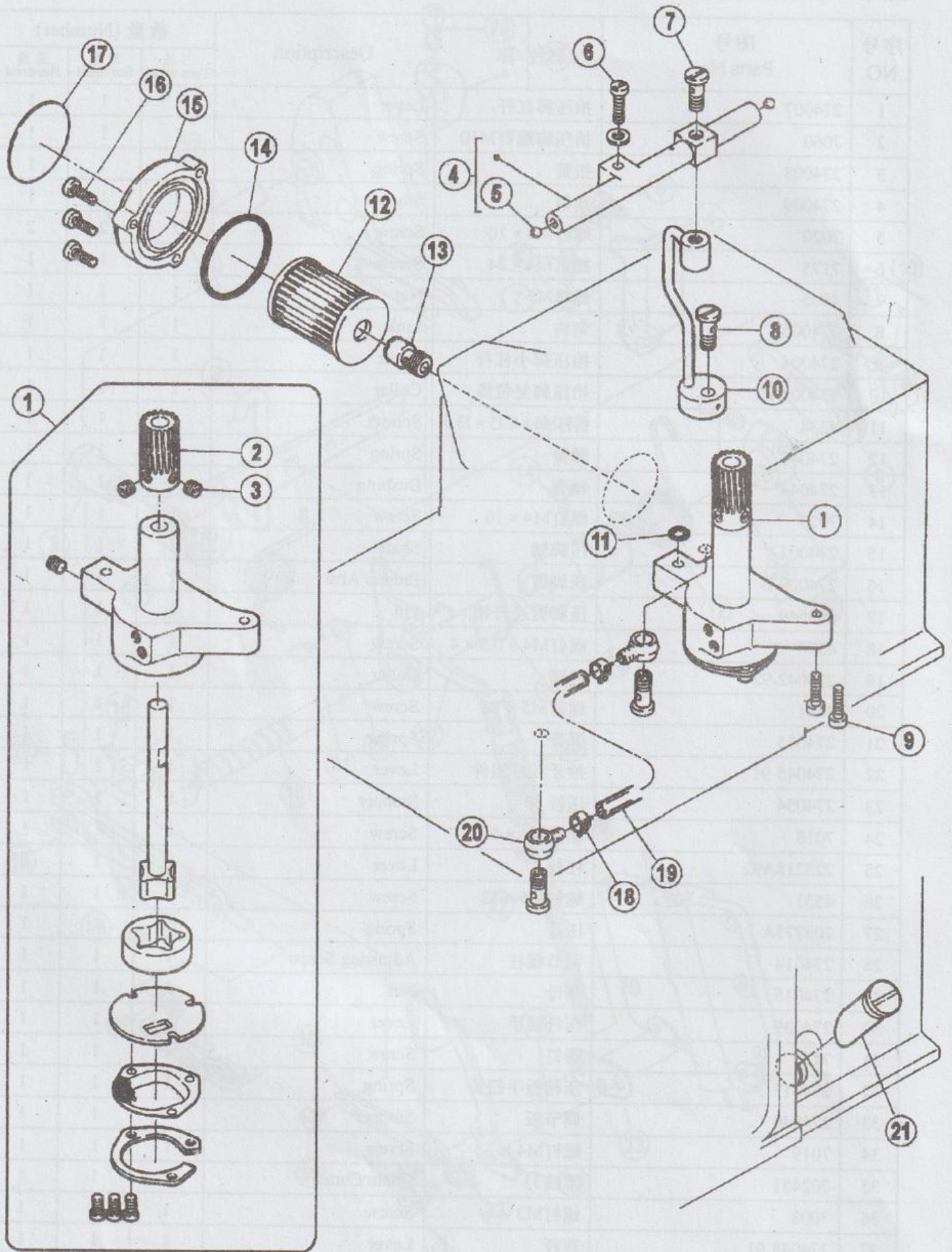

二十二、供油机构(1)/Lubrication Mechanism(1)

序号 NO	图号 Parts No.	名称	Description	数量 (Number)		
				三线 Three-thread	四线 Four-thread	五线 Five-thread
1	274546-91	油泵组件	Pump	1	1	1
2	211618	蜗轮	Worm Wheel	1	1	1
3	5060	螺钉M8 × 4.5	Screw	2	2	2
4	274515-91	分油器组件	Oil Distributor Complete	1	1	1
5	210214	滚珠	Plug	2	2	2
6	004211-HU0	组合螺钉M4 × 16	Screw	1	1	1
7	240328	过油螺钉	Joint Screw	1	1	1
8	240328	过油螺钉	Joint Screw	3	3	3
9	4529	螺钉M4 × 16	Screw	2	2	2
10	274532-91	分油器组件	Oil Distributor	1	1	1
11	204185	O型圈	O Ring	1	1	1
12	----	滤油器	Filter Element	1	1	1
13	274528	油线接座	Joint	1	1	1
14	206431	O型圈	O Ring	1	1	1
15	210201-SD	过滤器盖	Oil Filter Cap	1	1	1
16	7021	螺钉M4 × 12	Screw	3	3	3
17	9A3002	滤油器	Filter Element	1	1	1
18	202199	油管夹	Clamp	2	2	2
19	240327	油管Ø5 × Ø7	Tube	1	1	1
20	200136	油管接头	Joint	2	2	2
21	274539	油位标	Oil Sight Gauge	1	1	1

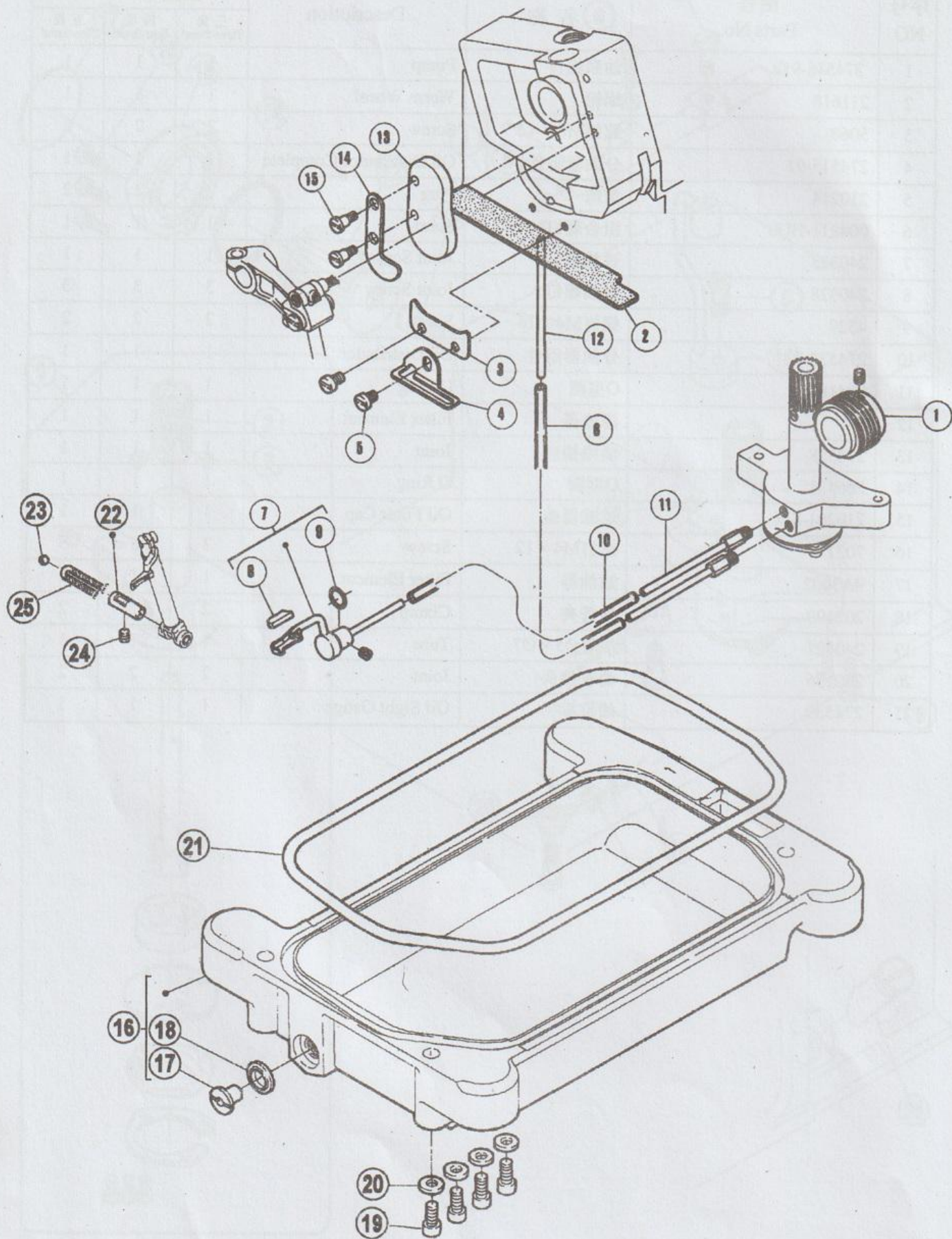

二十三、供油机构(2)/Lubrication Mechanism(2)

序号 NO	图号 Parts No.	名称	Description	数量 (Number)		
				三线 Three-thread	四线 Four-thread	五线 Five-thread
1	274504	蜗杆	Worm	1	1	1
2	274549	油毡	Felt	1	1	1
3	274550	压板	Cover	1	1	1
4	274559	挡板	Spacer	1	1	1
5	7018	螺钉M4 × 5	Screw	2	2	2
6	212152	油管	Tube	1	1	1
7	274552A-92	吸油嘴组件	Joint	1	1	1
8	274556	油毡	Felt	1	1	1
9	204185	O形圈	O Ring	1	1	1
10	210320	油管	Tube	1	1	1
11	209656A	铜油嘴	Joint	2	2	2
12	210320	吸油管	Exhaust Oil Distributor	1	1	1
13	274529	油毡	Felt	1	1	1
14	274530	板	Cover	1	1	1
15	7192	螺钉	Screw	2	2	2
16	274500	油盘	Oil Reservoir	1	1	1
17	5138B	放油螺钉	Screw	1	1	1
18	202287A	油盘放油垫圈	Washer	1	1	1
19	4531	螺钉M5 × 12	Bolt	4	4	4
20	240339	垫片	Washer	4	4	4
21	274501	油盘垫	Gasket	1	1	1
22	274514	上弯针滑杆过油器	Pipe Assy.	1	1	1
23	240338	滚珠	Ball	1	1	1
24	4543	螺钉M4 × 4	Screw	1	1	1
25	----	JK795油线	Oil wick	0.04	0.04	0.04

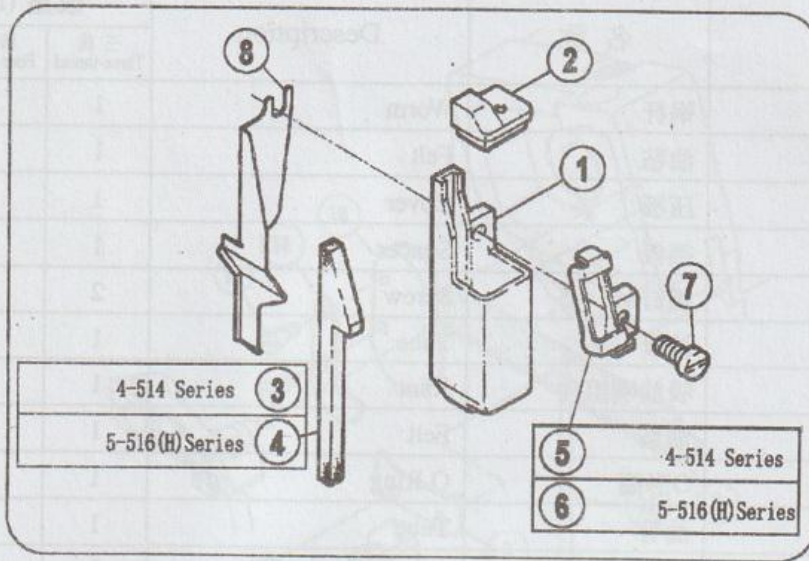

4-514 Series

5-516(H)Series

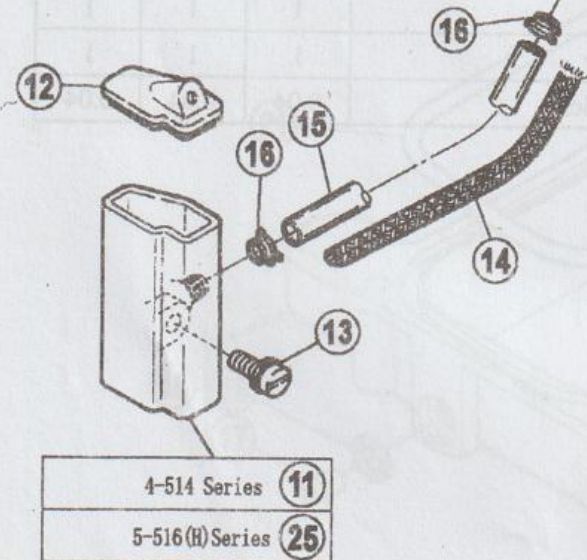
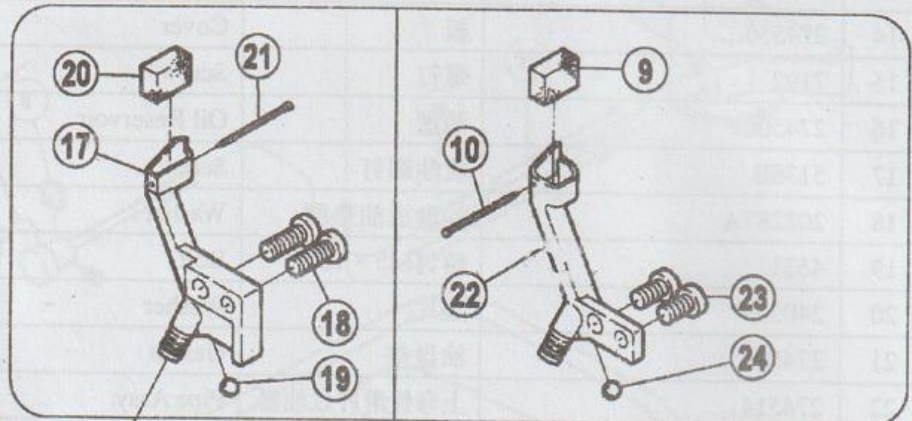

二十四、HR装置机构部件/H.R.Device

序号 NO	图号 Parts No.	名称	Description	数量 (Number)		
				三线 Three-thread	四线 Four-thread	五线 Five-thread
1	275500	上硅油盒	Silicone Oil Reservoir	1	1	1
2	275501	上硅油盒盖	Cover	1	1	1
3	275503	油毡	Felt	1	1	0
4	275546	毛毡	Felt	0	0	1
5	275502	过线架	Thread Guide	1	1	0
6	275507	过线架	Thread Guide	0	0	1
7	7020	螺钉M4 × 10	Screw	1	1	1
8	277888	挡油板	Cover	1	1	1
9	204466	油毡	Oil Felt	0	0	1
10	210766	别针	Pin	0	0	1
11	----	下硅油盒组件	Silicone Oil Reservoir	1	1	0
12	275505	下硅油盒盖	Cover	1	1	1
13	004210-HU0	组合螺钉M4 × 12	Screw	1	1	1
14	202175	油线	Oil Wick	1	1	1
15	240331	油管	Tube	1	1	1
16	200155	油管夹	Clamp	2	2	2
17	275506	针线冷却器	Needle Thread Lubricator	1	1	0
18	7021	螺钉M4 × 12	Screw	2	2	0
19	210214	滚珠	Plug	1	1	0
20	204466	油毡	Oil Felt	1	1	0
21	210766	别针	Pin	1	1	0
22	275509	针线冷却器	Needle Thread Lubricator	0	0	1
23	70196	螺钉M4 × 7.5	Screw	0	0	2
24	210214	滚珠	Plug	0	0	1
25	----	下硅油盒组件A	Silicone Oil Reservoir	0	0	1

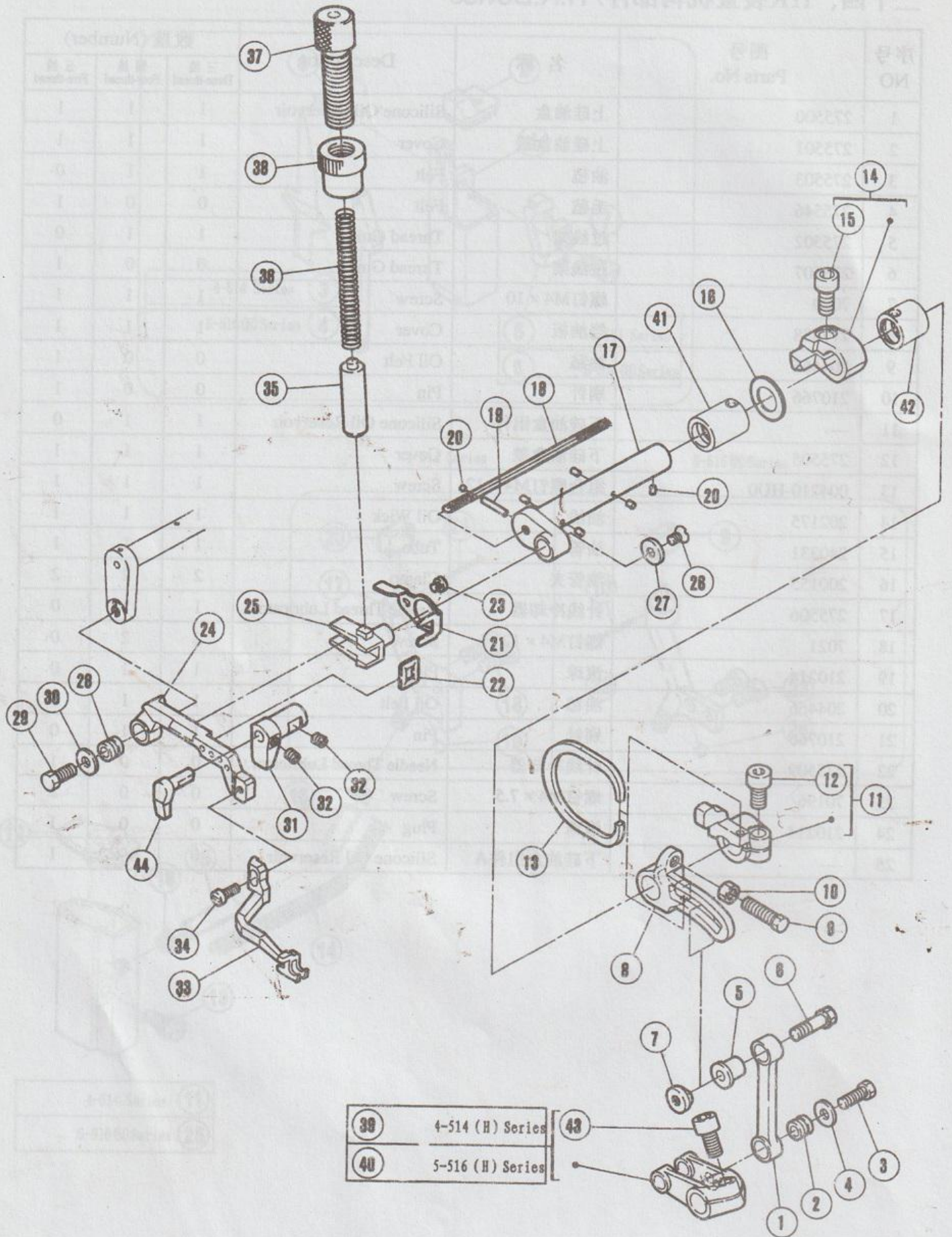

二十五、上送机构(1)/Top Feed Mechanism(1)

序号 NO	图号 Parts No.	名称	Description	数量 (Number)		
				三线 Three-thread	四线 Four-thread	五线 Five-thread
1	276534	连杆	Link	1	1	1
2	179160-05	衬套	Bushing	1	1	1
3	7056	螺钉M3×5	Screw	1	1	1
4	204115	垫片	Washer	1	1	1
5	276535	套	Bushing	1	1	1
6	7233	六角头螺栓	Bolt	1	1	1
7	276526	螺母	Nut	1	1	1
8	276533	曲柄	Crank	1	1	1
9	7206	六角头螺栓	Bolt	1	1	1
10	7207	螺母	Nut	1	1	1
11	276536-92	挡套	Collar	1	1	1
12	4533	螺钉M6×12	Screw	1	1	1
13	276538	卡簧	Flat Spring	1	1	1
14	276520-92	挡圈	Collar	1	1	1
15	4534	螺钉M6×14	Screw	1	1	1
16	240311	垫片	Washer	1	1	1
17	276527	曲柄轴	Crankshaft	1	1	1
18	——	JK788油线	Oil Wick	1	1	1
19	——	JK788油线	Oil Wick	1	1	1
20	——	塞子		6	6	6
21	276540	防油板	Guide	1	1	1
22	276539	油封	Oil Seal	1	1	1
23	7007	螺钉M3×3	Screw	1	1	1
24	276529	上送布架	Top Feed Bar	1	1	1
25	276530	上下导向	Guide	1	1	1
26	7044	螺钉M4×10	Screw	1	1	1
27	240294	垫圈	Washer	1	1	1
28	179160-05	衬套	Bushing	1	1	1
29	7056	螺钉M5×13	Screw	1	1	1
30	204115	垫片	Washer	1	1	1
31	276531	上送布架导向	Guide	1	1	1
32	4543	螺钉M4×4	Screw	1	1	1
33	277320	上送布齿	Top Feed Dog	1	1	1
34	7014	螺钉M3.5×10	Screw	1	1	1
35	274035	压紧杆	Presser Bar	1	1	1
36	240291	弹簧	Spring	1	1	1
37	274036	调压螺钉	Screw	1	1	1
38	274037	调压螺母	Nut	1	1	1
39	273001A92	上刀曲柄	Crank	0	1	0
40	273002A92	上刀曲柄	Crank	0	0	1
41	577600	轴套	Sleeve	1	1	1
42	577601	轴套	Sleeve	1	1	1
43	4533	螺钉M6×12	Screw	1	1	1
44	276532	上送布架导向	Guide	1	1	1

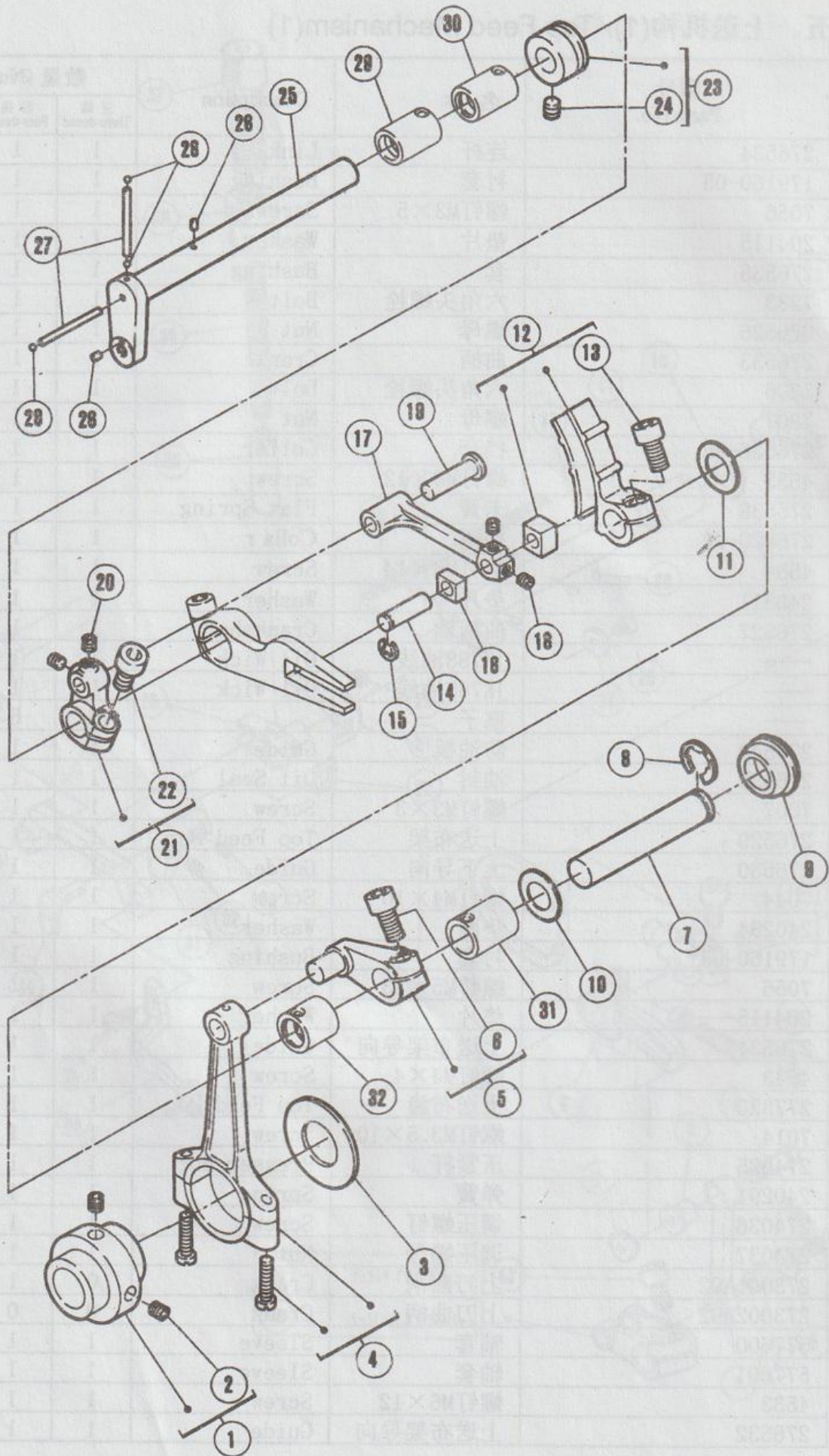

二十六、上送机构(2)/Top Feed Mechanism(2)

序号 NO	图号 Parts No.	名称	Description	数量 (Number)		
				三线 Three-thread	四线 Four-thread	五线 Five-thread
1	276500-92	偏心凸轮	Eccentric	1	1	1
2	4514	螺钉M5×5	Screw	2	2	2
3	240297	垫圈	Washer	1	1	1
4	276501-92	连杆组件	Connection	1	1	1
5	276502-92	曲柄	Crank	1	1	1
6	4533	螺钉M6×12	Screw	1	1	1
7	271003B	轴	Rod	1	1	1
8	202577	卡簧	Ring	1	1	1
9	2040110	塞子	Plug	1	1	1
10	208235	上刀架垫片	Washer	1	1	1
11	208235	上刀架垫片	Washer	1	1	1
12	276504-91	曲柄组件	Crank Assembly	1	1	1
13	4533	螺钉M6×12	Screw	1	1	1
14	276507	销	pin	1	1	1
15	201629	卡簧	Ring	1	1	1
16	276508	滑块	Block	1	1	1
17	276509	连杆	Link	1	1	1
18	4543	螺钉M4×4	Screw	2	2	2
19	276510	销	pin	1	1	1
20	4543	螺钉M4×4	Screw	2	2	2
21	276511-92	曲柄	Crank	1	1	1
22	4533	螺钉M6×12	Screw	1	1	1
23	276537-92	轴套	Collar	1	1	1
24	4514	螺钉M5×5	Screw	1	1	1
25	276512	轴	Crankshaft	1	1	1
26	207358	塞子	Oil Felt	3	3	3
27	——	JK788油线	Oil Wick	1	1	1
28	——	JK788油线	Oil Wick	1	1	1
29	577602	轴套	Sleeve	1	1	1
30	577603	轴套	Sleeve	1	1	1
31	577604	JK-798T3200-0235轴套	Sleeve	1	1	1
32	577601	轴套	Sleeve	1	1	1

二十七、上送机构(3)/Top Feed Mechanism(3)

序号 NO	图号 Parts No.	名称	Description	数量 (Number)		
				三线 Three-thread	四线 Four-thread	五线 Five-thread
1	276513-92	连杆	Lever	1	1	1
2	4534	螺钉M6×14	Screw	1	1	1
3	240296	挡圈	Collar	1	1	1
4	4521	螺钉M6×10	Screw	1	1	1
5	276515	板	Latch	1	1	1
6	276503	弹簧	Spring	1	1	1
7	276516	紧锁架	Latch	1	1	1
8	7019	螺钉M4×8	Screw	1	1	1
9	276514	轴	Rod	1	1	1
10	201022	O型圈	O Ring	1	1	1
11	276517	连接板	Lever	1	1	1
12	7077	螺钉M4×7	Screw	2	2	2
13	276519	调节螺母	Nut	1	1	1
14	7059	螺钉	Screw	1	1	1
15	211301	蝶形垫片	Spring Washer	1	1	1
16	276518	调节板	Blade guide	1	1	1
17	7026	螺钉M4×25	Screw	3	3	3
18	240332	挡套	Spacer	3	3	3
19	276524	挡板	Stopper	1	1	1
20	4531	螺钉M5×12	Screw	2	2	2
21	179201-15	螺母	Nut	2	2	2
22	240339	垫片	Washer	1	1	1
23	303448	调节杆	Adgusting Bar	1	1	1
24	272538A	标签	Seal	1	1	1
25	210533	弹簧	Spring	1	1	1
26	272539A	螺母	Pin	1	1	1
27	240322	卡簧	Ping	1	1	1
28	577606	轴套	Sleeve	1	1	1
29	577608	轴套	Sleeve	1	1	1

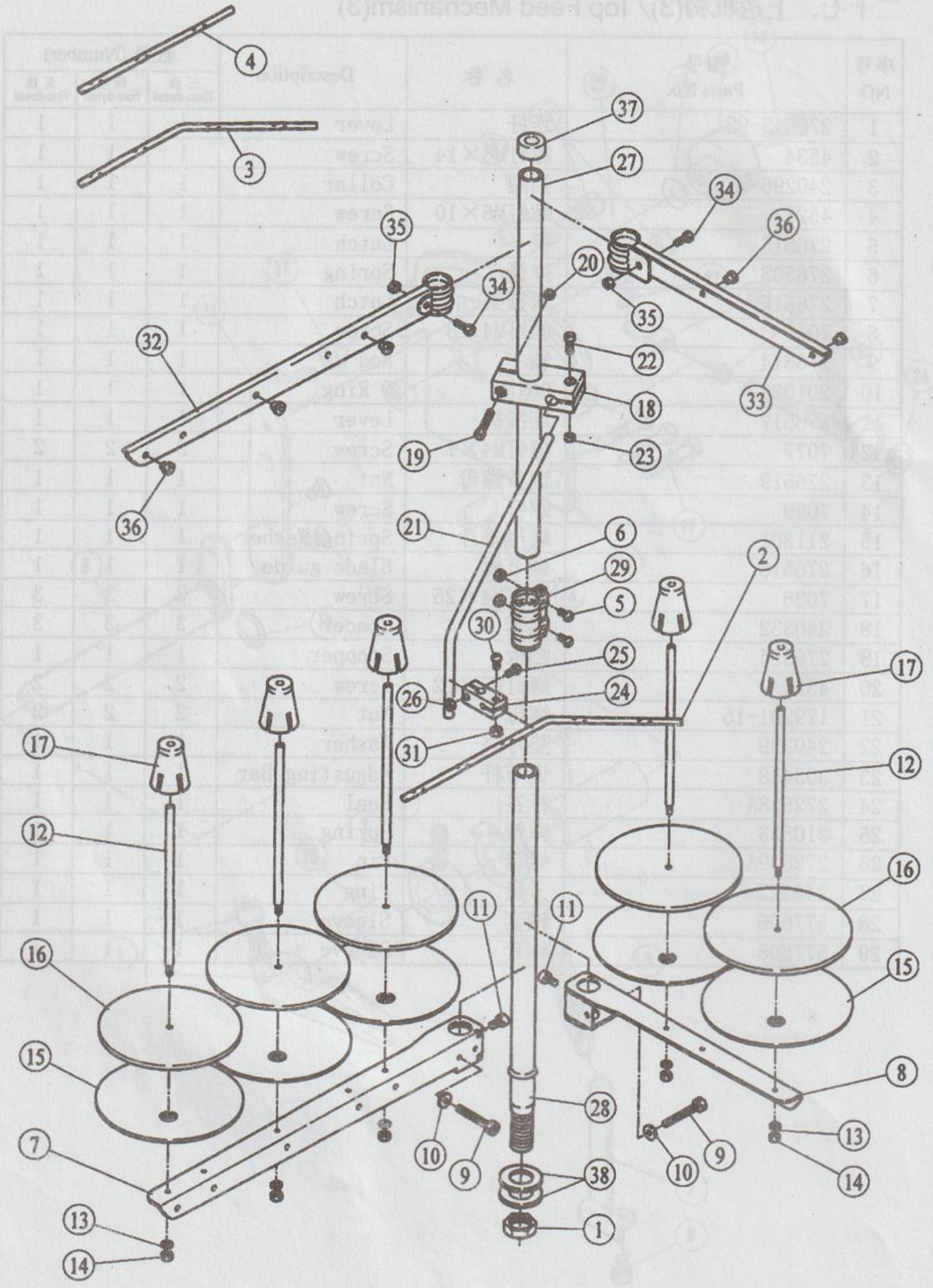

二十八、线架部件/Thread Stand

序号 NO	图号 Parts No.	名称	Description	数量 (Number)		
				三线 Three-thread	四线 Four-thread	五线 Five-thread
1	4835	螺母	Nut	1	1	1
2	293A	过线棒	Thread guide(5-spool)	0	0	1
3	293B	过线棒	Thread guide(4-spool)	0	1	0
4	293C	过线棒	Thread guide(3-spool)	1	0	0
5	4021	螺钉	Screw	2	2	2
6	----	螺母M5	Nut	2	2	2
7	505-PA	长线架	Thread hanger	1	0	1
8	505APA	短线架	Thread hanger	1	2	1
9	7102	螺钉	Screw	0	2	2
10	512	垫片	Washer	1	2	2
11	4022	螺钉	Screw	1	2	2
12	380A	线棒	Spool pin	3	4	5
13	201252	垫片	Spring washer	3	4	5
14	4803	螺母	Nut	3	4	5
15	381-PA	托盘垫	Spool seat disc	3	4	5
16	507	线托盘	Spool mat	3	4	5
17	382-PA	线固定套	Spool cushion	3	4	5
18	383-PA	棒架	Holder	1	1	1
19	4014	螺钉	Screw	1	1	1
20	4803	螺母	Nut	1	1	1
21	384	导线棒	Thread guide arm	1	1	1
22	4012	螺钉	Screw	1	1	1
23	4803	螺母	Nut	1	1	1
24	233-PA	固定器	Holder	1	1	1
25	4012	螺钉	Screw	1	1	1
26	4803	螺母	Screw	1	1	1
27	502-PA	线架上棒	Column pipe (upper)	1	1	1
28	503-PA	线架下棒	Column pipe (lower)	1	1	1
29	504-PA	锁紧卡固	Joint	1	1	1
30	4012	螺钉	Screw	1	1	1
31	4803	螺母	Nut	1	1	1
32	527-PA	长过线架	Thread hanger	1	0	1
33	527APA	短过线架	Thread hanger	1	2	1
34	4021	螺钉	Screw	1	2	2
35	----	螺母M5	Nut	1	2	2
36	506	过线套	Thread eyelet	3	4	5
37	386	棒帽	Rod cap	1	1	1
38	509	垫片	Washer	2	2	2

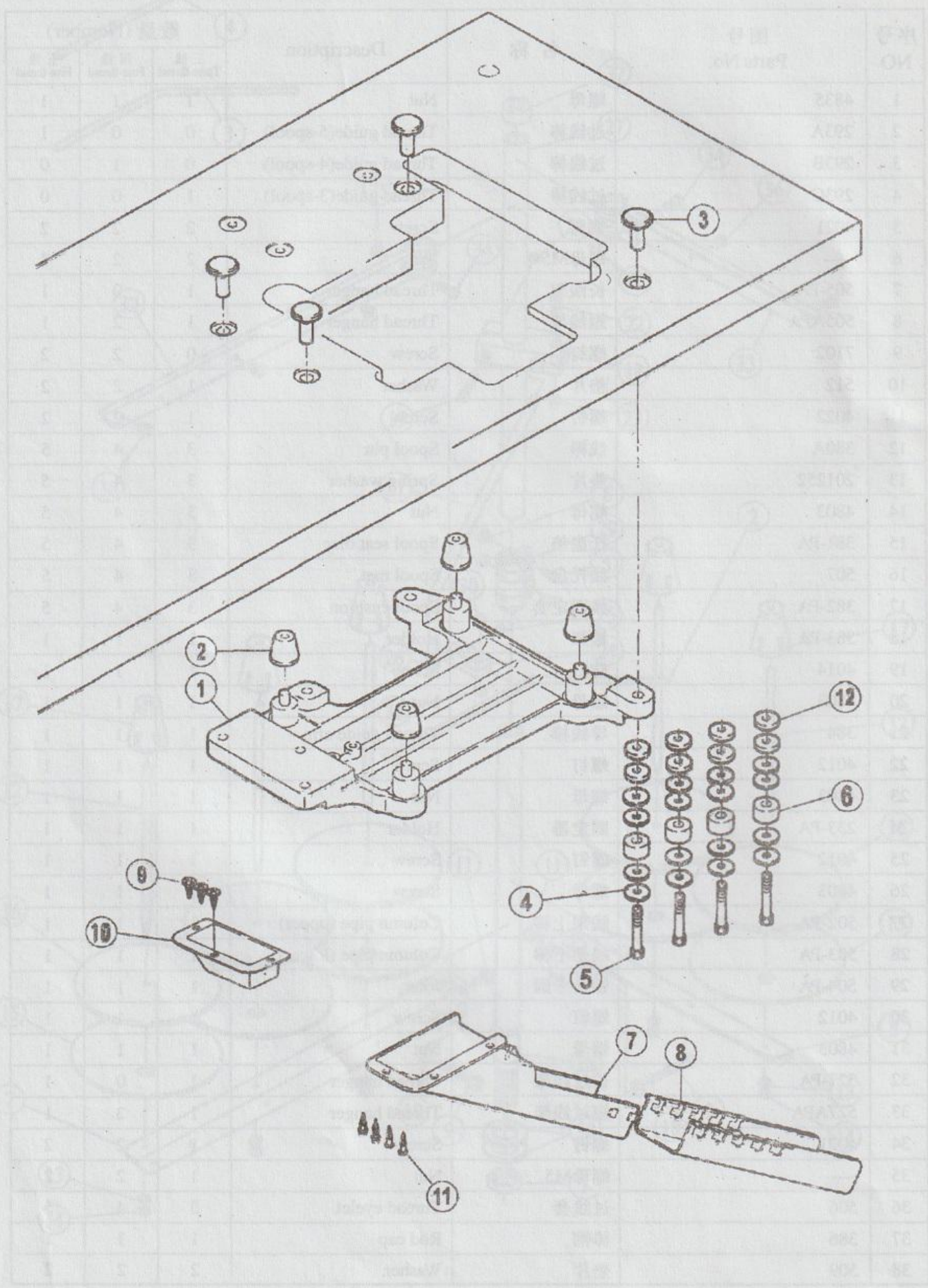

二十九、托盘部件/Parts For Semi-Submerged Installation

序号 NO	图号 Parts No.	名称	Description	数量 (Number)		
				三线 Three-thread	四线 Four-thread	五线 Five-thread
1	276001	托盘	Rest Board	1	1	1
2	179483-05	托盘防震连接垫	Cushion Rubber	4	4	4
3	206336	托盘固定螺母	Nut	4	4	4
4	----	大垫圈	Spacer	16	16	16
5	4512	托盘内六角螺钉	Screw	4	4	4
6	----	防震套	Washer	4	4	4
7	205468-PA	排料槽I	Waste Chute	1	1	1
8	205469-PA	排料槽II	Waste Chute	1	1	1
9	4904	排料槽座螺钉	Screw	3	3	3
10	205470-PA	排料槽座	Screw	1	1	1
11	4905	排料槽螺钉	Washer	4	4	4
12	----	减震垫圈	Spring Washer	8	8	8

4-514(H) Series

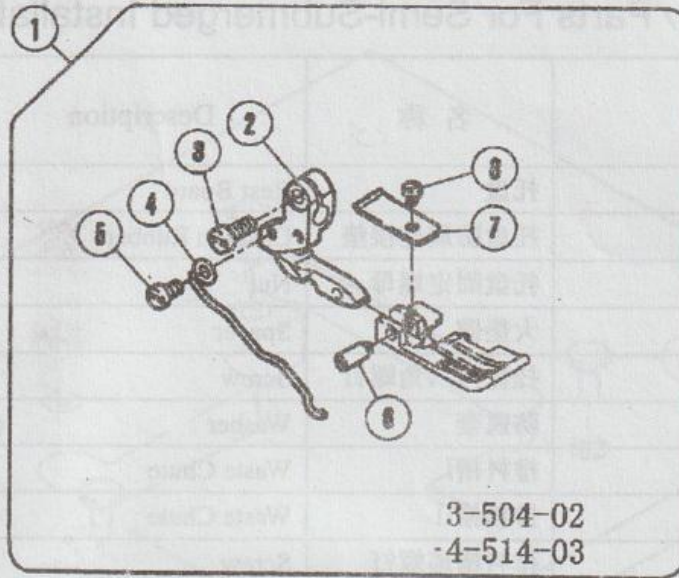

5-516(H) Series

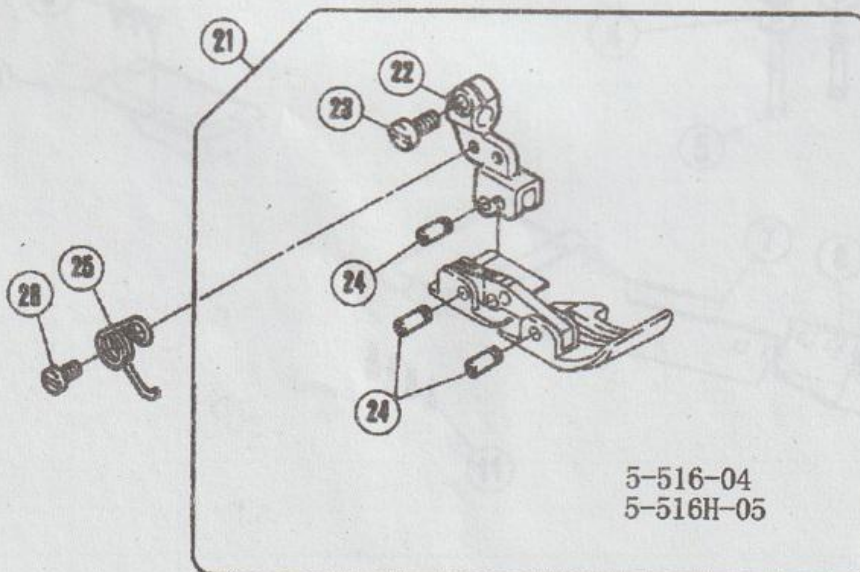
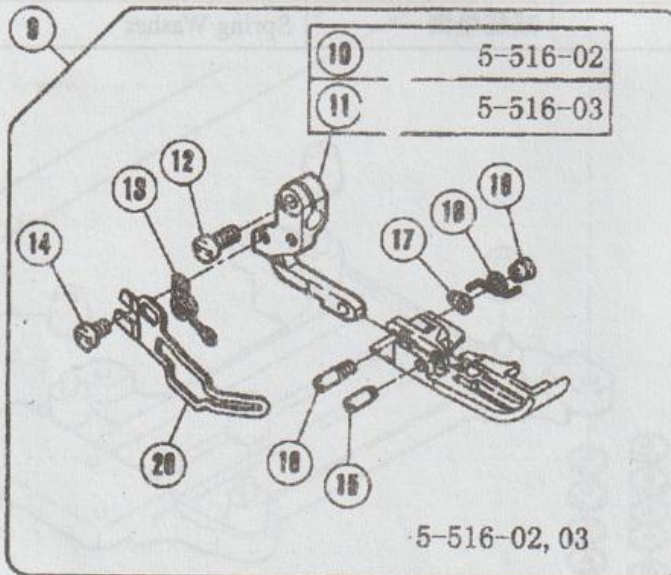

三十、专用零件/Specific Parts

序号 NO	图号 Parts No.	名称	Description	数量 (Number)		
				三线 Three-thread	四线 Four-thread	五线 Five-thread
1	xxxxxxx	压脚组件	Presser Foot Assy.	0	0	1
2	7013	螺钉M3.5 × 7.5	Screw	0	0	2
3	208958-B	销	Pin	0	0	4
4	277108	护料压板	Fabric Guard	0	0	1
5	202875	垫圈3	Washer	0	0	1
6	5157	螺钉	Screw	0	0	1
7	274024	压脚弹簧	Spring	0	0	1
8	7166	轴位螺丝	Screw	0	0	1
9	274027	压脚垫片	Finger Guard	0	0	1
10	7009	螺钉M3 × 4.5	Screw	0	0	1
11	xxxxxxx	压脚组件	Presser Foot Complete	0	0	1
12	212499-B	销	Pin	0	0	1
13	5409	螺母	Nut	0	0	1
14	212498	销	Latch	0	0	1
15	274028	弹簧	Spring	0	0	1
16	3153	螺母	Nut	0	0	1
17	208531	辅助压脚	Fabric Guide	0	0	1
18	5030	螺钉M1 × 2.3	Screw	0	0	1
19	274022	压脚弹簧	Spring	0	0	1
20	7009	螺钉M3 × 4.5	Screw	0	0	1
21	274026	压脚护手	Finger Guard	0	0	1
22	7008	螺钉M3 × 4	Screw	0	0	1
23	xxxxxxx	压脚组件	Holder	0	0	1
24	7013	螺钉M3.5 × 7.5	Screw	0	0	1
25	274023	压脚弹簧	Spring	0	0	1
26	7009	螺钉M3 × 4.5	Screw	0	0	1
27	274025	压脚护手	Finger Guard	0	0	1
28	7008	螺钉M3 × 4	Screw	0	0	1
29	xxxxxxx	压脚组件	Presser Foot Complete	0	0	1
30	211919	销	Pin	0	0	1
31	211918	弹簧	Spring	0	0	1
32	3150	螺母	Nut	0	0	1
33	211920	销	Spring Pin	0	0	1
34	xxxxxxx	压脚爪	Presser Foot	0	0	1
35	xxxxxxx	压脚爪	Presser Foot	0	0	1
36	211917	安装板	Bracket	0	0	1
37	5089	螺钉M3.5 × 5.5	Screw	0	0	1
38	----	垫片	Washer	0	0	1
39	275030A	过线板	Thread Eyelet	0	0	1
40	240347	压簧	Spring	0	0	1

褶皱 (Shirring)

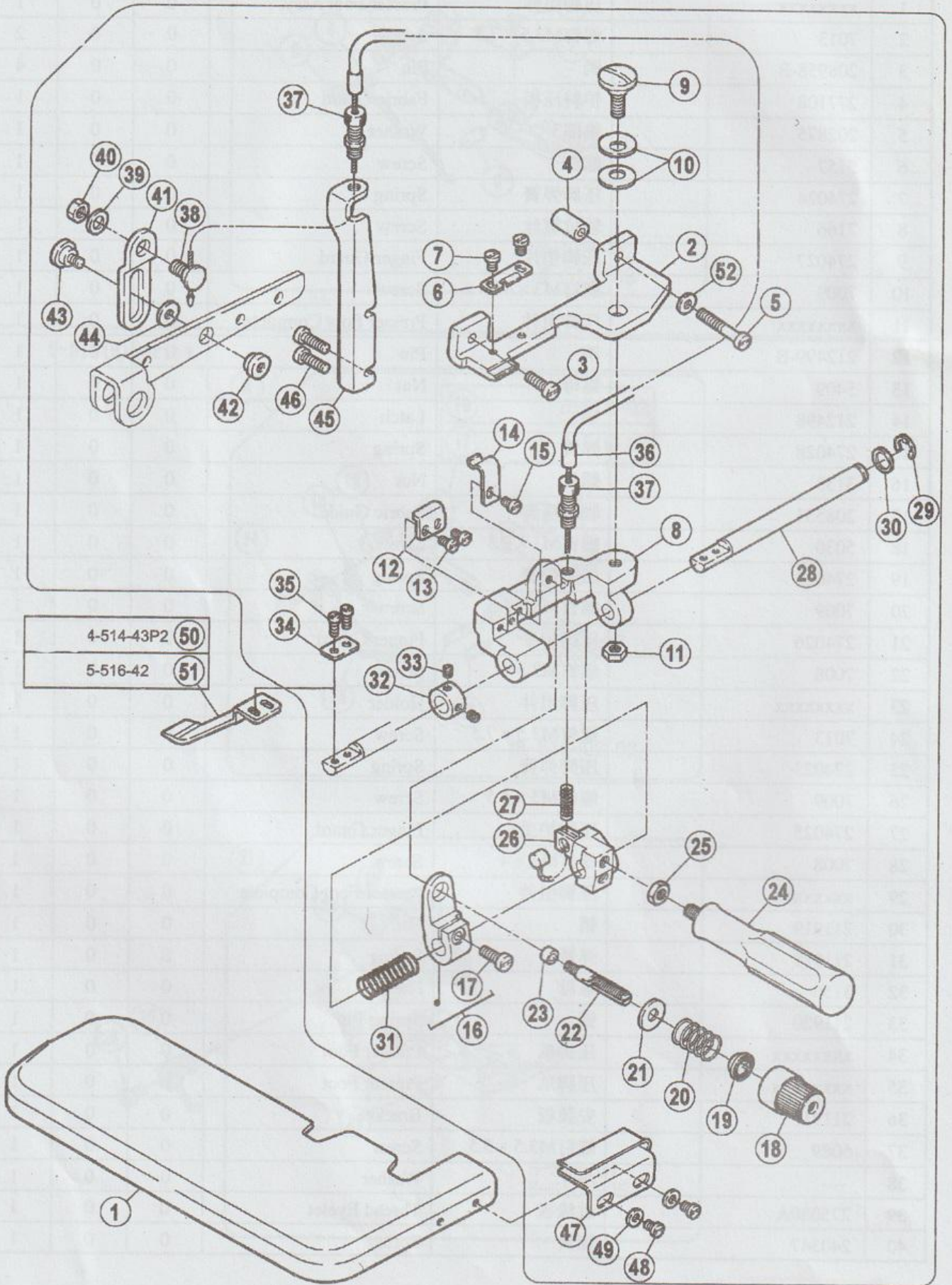

三十一、专用零件/Specific Parts

序号 NO	图号 Parts No.	名称	Description	数量 (Number)		
				三线 Three-thread	四线 Four-thread	五线 Five-thread
1	270035B	缝台	Cloth Plate	0	1	1
2	275515	打褶器连接板	Bracket	0	1	1
3	---	螺钉M4×13.5	Screw	0	1	1
4	240332	连接板垫片	Spacer	0	1	1
5	7191	连接板右侧螺钉	Screw	0	1	1
6	210947	支架	Flat Spring	0	1	1
7	1206	螺钉	Screw	0	2	2
8	275516	打褶器支座	Bracket	0	1	1
9	7160	连接板固定螺钉	Screw	0	1	1
10	204888	连接板垫片	Spring	0	2	2
11	4806	连接固定螺母	Nut	0	1	1
12	210945	小连接板	Bracket	0	1	1
13	5328	小连接板螺钉	Screw	0	2	2
14	210946	支架弹簧板	Flat Spring	0	1	1
15	1206	螺钉	Screw	0	1	1
16	275517-92	打褶皱座	Spring Guide	0	1	1
17	7021	螺钉	Screw	0	1	1
18	208447-UA	调压螺母	Nut	0	1	1
19	208448	调压止动套	Ratchet	0	1	1
20	210940	调压簧	Spring	0	1	1
21	204091	夹线器垫片	Washer	0	1	1
22	5082A	螺钉	Screw Stud	0	1	1
23	210944	调压螺钉套	Washer	0	1	1
24	275518	手柄	Lever	0	1	1
25	4806	连接固定螺母	Nut	0	1	1
26	275520	手柄座	Bracket	0	1	1
27	240320	弹簧	Spring	0	1	1
28	275521	打褶器轴	Shaft	0	1	1
29	202522	卡簧	Ring	0	1	1
30	207045	垫片	Washer	0	1	1
31	240323	弹簧	Spring	0	1	1
32	206225	挡圈	Collar	0	1	1
33	1457	螺钉	Screw	0	2	2
34	210955	方板	Washer	0	1	1
35	5029	螺钉	Screw	0	2	2
36	212435	松线组件	Cable	0	1	1
37	212436	支座接头螺钉	Cable Support	0	2	2
38	7099	带孔螺钉	Screw	0	1	1
39	202433	垫片	Washer	0	1	1
40	4803	连接固定螺母	Nut	0	1	1
41	275522	吊板	Latch	0	1	1
42	179765-15	螺母	Nut	0	1	1
43	7164	吊板螺钉	Screw	0	1	1
44	240104	垫片	Washer	0	1	1
45	275523	托架	Bracket	0	1	1
46	7022	螺钉M4×17.5	Screw	0	2	2
47	210961	卷边器	Fabric Guide	0	1	1
48	7012	螺钉M3.5×5.7	Screw	0	2	2
49	137906	垫片	Washer	0	2	2
50	275524	板	Blade	0	1	1
51	275525	打褶器	Blade	0	1	1
52	200098	连接板右侧垫片	Washer	0	1	1

下摆卷边缝 (Blindhemming)

3-505-12

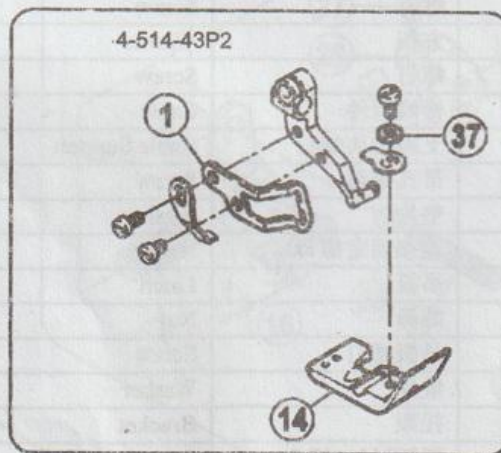
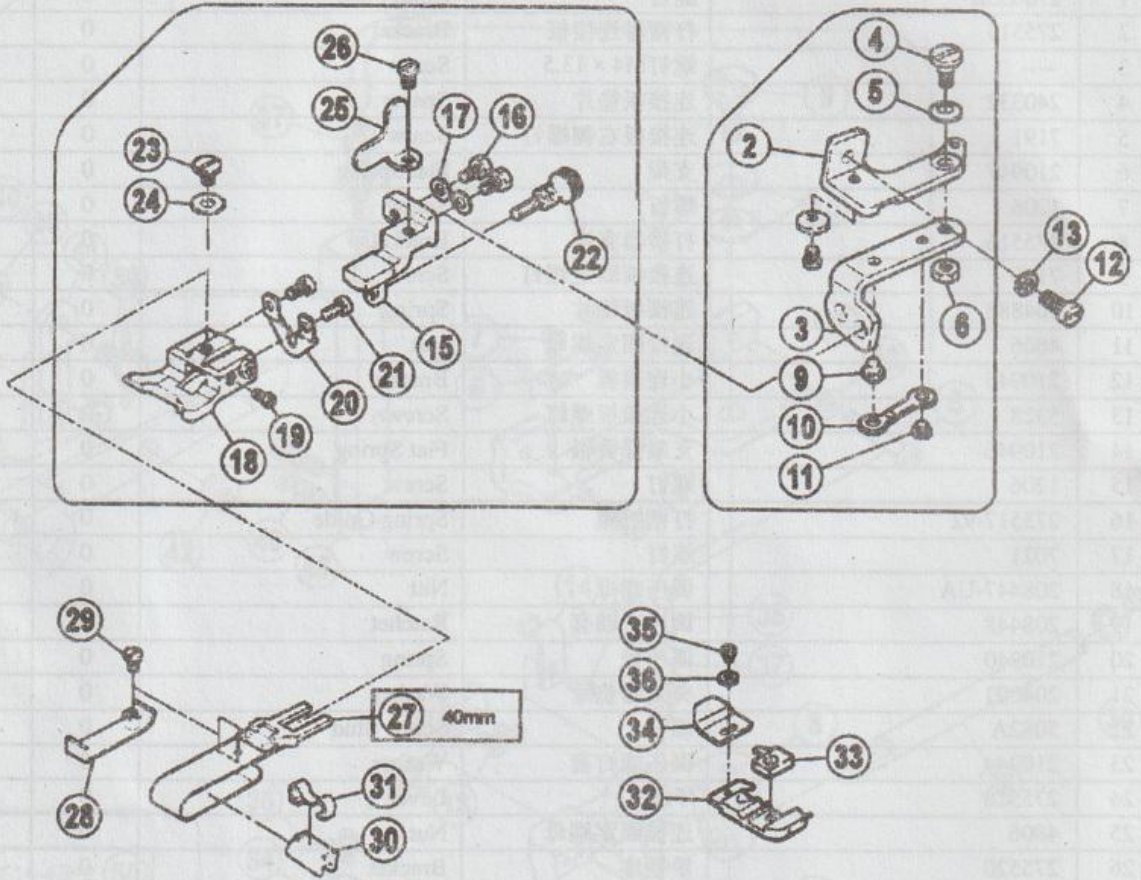

三十二、专用零件/Specific Parts

序号 NO	图号 Parts No.	名称	Description	数量 (Number)		
				三线 Three-thread	四线 Four-thread	五线 Five-thread
1	274033	压脚护手	Finger Guard	0	1	0
2	210680	送料支架	Cloth Plate Bracket	1	0	0
3	210681	铰链	Hinge Guide Bracket	1	0	0
4	5184	螺钉	Screw	1	0	0
5	201191	垫圈	Spring	1	0	0
6	3044	螺母	Nut	1	0	0
7	----	----	----	----	----	----
8	----	----	----	----	----	----
9	210683	铰链销	Pin	1	0	0
10	210684	铰链弹簧	Flat Spring	1	0	0
11	2906	螺钉	Screw	1	0	0
12	7019	螺钉M4×8	Screw	1	0	0
13	----	垫圈4	Spring Washer	1	0	0
14	xxxxxxxx	压脚	Presser Foot	1	0	0
15	210690	支架	Bracket	1	0	0
16	5088	螺钉	Bolt	2	0	0
17	167066	垫片	Washer	2	0	0
18	205361	固定块	Bracket	1	0	0
19	5057	螺钉	Screw	1	0	0
20	210689	挡板	Ajusting Plate	1	0	0
21	5157	螺钉	Screw	2	0	0
22	2430	螺钉	Screw	1	0	0
23	2905	螺钉	Screw	1	0	0
24	137142	垫片	Washer	1	0	0
25	210692	角板	Stopper	1	0	0
26	1206	螺钉	Screw	1	0	0
27	201211C91	导向片	Folder Assy.	1	0	0
28	205835	挡板	Auxiliary Plate	1	0	0
29	5299	螺钉	Screw	1	0	0
30	303312A	垫块	Stopper	1	0	0
31	303313	弹簧片	Clamp	1	0	0
32	xxxxxxxx	压脚	Presser Foot	1	0	0
33	xxxxxxxx	压脚爪	Presser Foot Finger	1	0	0
34	210584	辅助压脚板	Uncurler	1	0	0
35	5030	螺钉M1×2.3	Screw	1	0	0
36	210585	垫圈	Washer	1	0	0
37	202588	垫圈	Washer	0	1	0

三十三、专用零件/Specific Parts

序号 NO	图号 Parts No.	名称	Description	数量 (Number)		
				三线 Three-thread	四线 Four-thread	五线 Five-thread
1	275542-91	送带导向组件	Tape Guide Assy.	0	1	0
2	245510	送带导向	Tape Guide	0	1	0
3	7066	螺钉M4	Screw	0	1	0
4	210307	垫圈	Washer	0	2	0
5	275511	送带导向	Tape Guide	0	1	0
6	211267	过带	Tape Take-up	0	1	0
7	208735	过带导向	Tape Guide	0	1	0
8	1216	螺钉	Screw	0	1	0
9	XXXXXXXX	压脚	Presser Foot	0	1	0
10	XXXXXXXX	压脚爪	Presser Foot Finger	0	1	0
11	211600	辅助压脚板	Uncurler	0	1	0
12	5030	螺钉M1 × 2.3	Screw	0	1	0
13	240302	衬套	Spacer	0	1	0
14	275054	挑线架	Thread Take-up	0	1	0

(Attaching U-shaped tape)

5-516-53

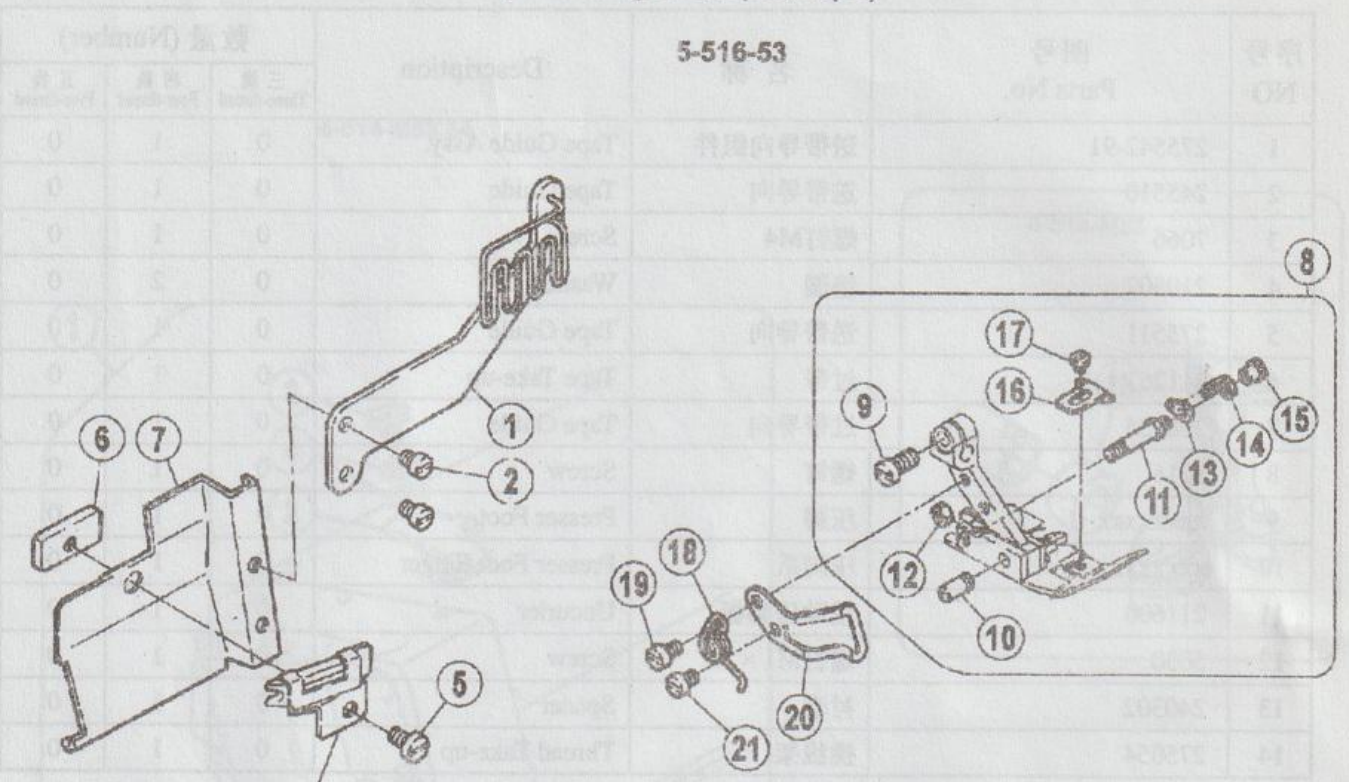

SW=5mm	3
SW=4mm	4

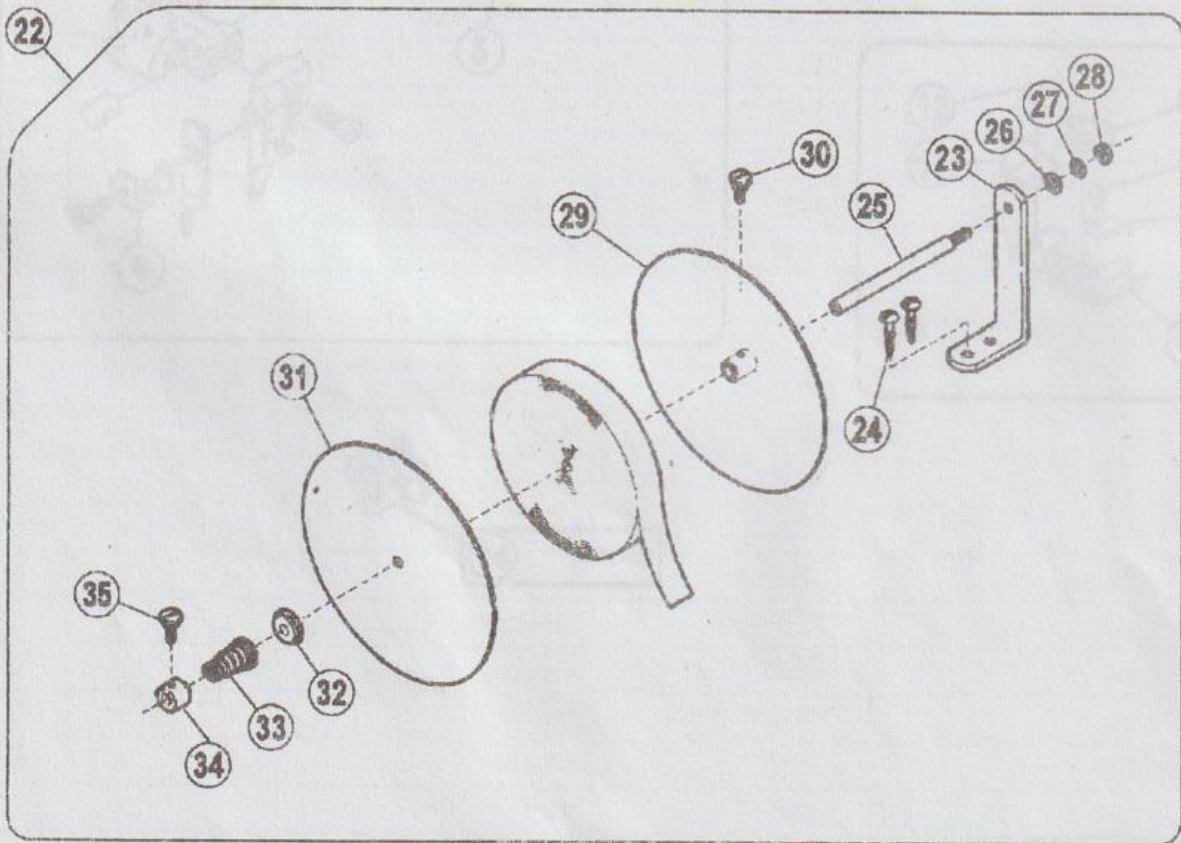

三十四、专用零件/Specific Parts

序号 NO	图号 Parts No.	名称	Description	数量 (Number)		
				三线 Three-thread	四线 Four-thread	五线 Five-thread
1	275512	过带导向	Tape Guide	0	0	1
2	7180	螺钉M3.5 × 4.5	Screw	0	0	2
3	209200	卷边器(10)	Binder(10)	0	0	1
4	208994	卷边器(8)	Binder(8)	0	0	1
5	1216	螺钉	Screw	0	0	1
6	208997	卷边器固定座	Binder Guide	0	0	1
7	270013A	左前盖	Front Cover(Left)	0	0	1
8	XXXXXXXX	压脚组件	Presser Foot Assy.	0	0	1
9	7013	螺钉	Screw	0	0	1
10	208958-B	销	Pin	0	0	1
11	212499-B	销	Pin	0	0	1
12	5409	螺母	Nut	0	0	1
13	212498	销	Latch	0	0	1
14	274028	弹簧	Spring	0	0	1
15	3153	螺母	Nut	0	0	1
16	208531	辅助压脚	Fabric Guide	0	0	1
17	5030	螺钉M1 × 2.3	Screw	0	0	1
18	274022	压脚弹簧	Spring	0	0	1
19	7009	螺钉M3 × 4.5	Screw	0	0	1
20	274026	压脚护手	Finger Guard	0	0	1
21	7008	螺钉M3 × 4	Screw	0	0	1
22	337	线盘组件	Tape Disc Assy.	0	0	1
23	344	支架	Bracket	0	0	1
24	4911	螺钉	Screw	0	0	2
25	341	轴	Rod	0	0	1
26	189	垫圈	Washer	0	0	1
27	303067	上弯针垫圈	Spring Washer	0	0	1
28	4805	螺母	Nut	0	0	1
29	338	线盘	Tape Reel Stand	0	0	1
30	339	螺钉	Screw	0	0	1
31	340	盖板	Tape Reel Stand Cover	0	0	1
32	467	弹簧座	Spring Seat	0	0	1
33	343	弹簧	Spring	0	0	1
34	468	挡圈	Collar	0	0	1
35	339	螺钉	Screw	0	0	1

3-504-32R2
 4-514-M03,M53,M54
 5-516-02A,03,A04

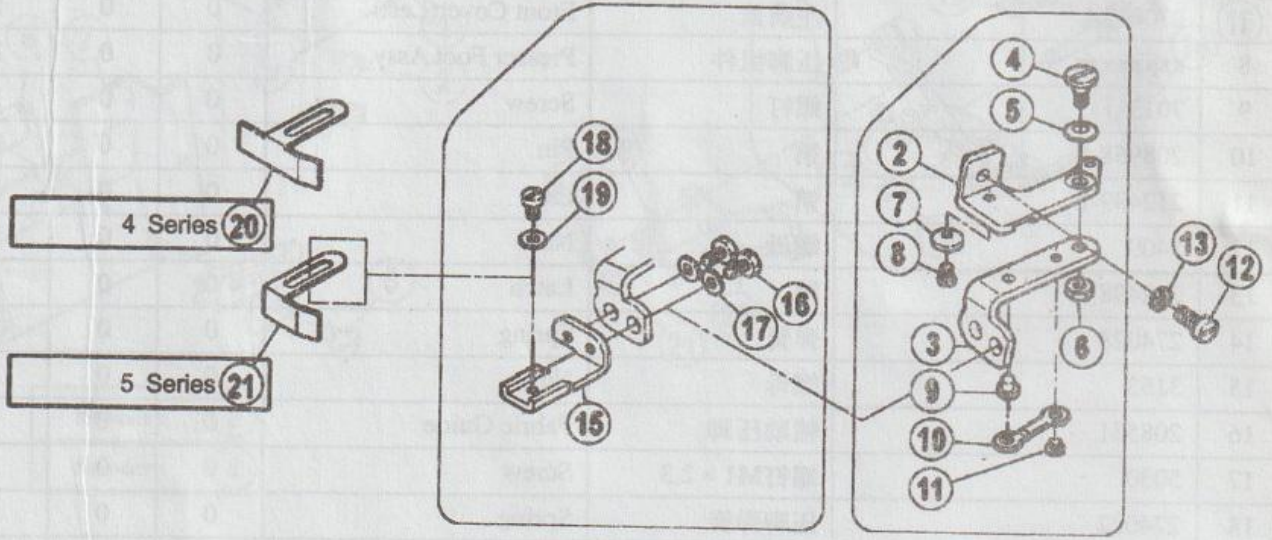

卷邊縫 (Turn down hemming)

3-504-32R2

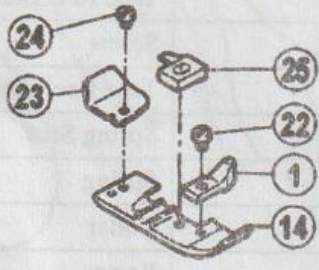

三十五、专用零件/Specific Parts

序号 NO	图号 Parts No.	名称	Description	数量 (Number)		
				三线 Three-thread	四线 Four-thread	五线 Five-thread
1	277150-40	压脚	Presser Foot	1	0	0
2	210680	送料支架	Cloth Plate Bracket	1	1	1
3	210681	铰链	Hinge Guide Bracket	1	1	1
4	5184	螺钉	Screw	1	1	1
5	201191	垫圈	Spring	1	1	1
6	3044	螺母	Nut	1	1	1
7	----	----	----	----	----	----
8	----	----	----	----	----	----
9	210683	铰链销	Pin	1	1	1
10	210684	铰链弹簧	Flat Spring	1	1	1
11	2906	螺钉	Screw	1	1	1
12	7019	螺钉M4 × 8	Screw	1	1	1
13	---	垫圈4	Spring Washer	1	1	1
15	210687	挡料板座	Edge Guide Bracket	1	1	1
16	5088	螺钉M4 × 7.5	Bolt	2	2	2
17	167066	垫片	Washer	2	2	2
18	1202	螺钉C4	Screw	1	1	1
19	167066	垫片	Washer	1	1	1
20	204667	挡料板	Edge Guide	1	1	0
21	201233A	挡料板	Edge Guide	0	0	1

3/4 标准度量零件表

3/4 GAUGE PARTS LIST

机型 MACHINE TYPE /SPEC	间距		针板 NEEDLE PLATE	主送齿组件 MAIN FEED DOG ASSM.	主送齿 MAIN FEED DOG	辅送齿 AUX. FEED DOG	差动齿 DIFF. FEED DOG	压脚组件 PRESSER FOOT ASSM.	压脚爪 PRESSER FOOTFINGER	上弯针 UPPER LOOPER	下弯针 LOWER LOOPER	上差动齿 TOP FEED DOG
	NG	SW										
3-504-02/233	—	4	20715005	2071460100	20714001	20714002	20714603	2071600700	20701022	20717604	20717006	277345A30F
3-505-12/223	—	4	20715009	2071400600	20714006	20714002	20714007	2071600800	20701040	20717004	20717006	277345
4-514-M03/333	2	4	20715002	2071400100	20714001	20714002	20714603	2071600700	20701019	20717003	20717006	277345
4-514-43P2/333	2	4	20715002	2071400900	20714009	20714002	20714610	2071601200	—	20717003	20717006	277345

机型 MACHINE TYPE /SPEC	间距		上刀		下刀 LOWER KNIFE	护针		针夹头 NEEDLE HOLDER	针 NEEDLE
	NG	SW	平刀 FLAT NIFE	角刀 ANGLED KNIFE		前 OVERLOCK FRONT	后 NEEDLE GUARD READ		
1-504-02/233	—	4	20619002	—	20619003	20717001	20717002	20734001	DCX27 #8
3-505-12/223	—	4	20619002	—	20619003	20717001	20717002	20734001	DCX27 #9
4-514-M03/333	2	4	20619002	—	20619003	20717001	20717002	20734002	DCX27 #9
4-514-43P2/333	2	4	20619002	—	20619003	20717001	20717002	20734002	DCX27 #11

标准度量零件表

GAUGE PARTS LIST

机型 MACHINE TYPE /SPEC	间距		针板 NEEDLE PLATE	主送齿组件 MAIN FEED DOG ASSM.	主送齿 MAIN FEED DOG	辅送齿 AUX. FEED DOG	差动齿 DIFF. FEED DOG	压脚组件 PRESSER FOOT ASSM.	上弯针 UPPER LOOPER	下弯针 LOWER LOOPER	链线弯针 CHAIN STITCH LOOPER	上差动齿 TOP FEED DOG
	NG	SW										
5-516-02A/223	3	4	20715051	2071405400	20714054	20714002	20714055	20716050	20717004	20717006	20712047	277345A20F
1-516-03/333	3	4	20715008	2071400400	20714004	20714002	20714007	2071600600	20717004	20717006	20712047	277345
5-516-A04/435	5	6	20715050	2071405200	20714052	20714002	20714050	2070105400	20717050	20717006	20717051	277345
5-516-42/233	3	4	20715011	2071401100	20714011	20714002	20714012	2071600900	20717003	20717006	20712047	277345

机型 MACHINE TYPE /SPEC	间距		上刀		下刀 LOWER KNIFE	护针		护针 CHAIN STITCH GUARD NEEDLE	针夹头 NEEDLE HOLDER	针 NEEDLE		
	NG	SW	平刀 FLAT NIFE	角刀 ANGLED KNIFE		前 OVERLOCK FRONT	后 NEEDLE READ				前 FRONT	后 READ
3-516-02A/223	3	4	20719001	---	20619003	20717008	20717002	20712045	20734003	DCX27 # 11		
5-516-03/333	3	4	20619002	---	20619003	20717008	20717002	20712045	20734004	DCX27 # 14		
5-516-A04/435	5	6	---	20719050	20701053	20717008	20717002	20712045	20719056	DCX27 # 21		
5-516-42/233	3	4	20619002	---	20619003	20717008	20717002	20712045	20734003	DCX27 # 11		