

Chines

NT8310A-1085
-DUser's

87

At the purpose of Record

1. Species Grid	1
2. Each Department Of the Name Called	2
3. Ann Machine	3
3-1. Sewing machine installation	3
3-1-1. Remove the packaging	3
3-1-2. X-feeding installation	5
3-1-3. Table of the desktop	7
3-1-4. Install the switch, the winding device and the switch button (group)	8
3-1-5. Turn on the insurance before and after the precautions	9
3-2. Air hose installation	11
3-3. Precautions for compressed air source (air supply) equipment	12
3-4. Install the cylindrical device	13
3-5. Bottom line winding method	13
3-6. Consumption for mechanical settings	14
4. Seam Mounting Machine Of the Quasi Prepare	15
4-1. Approaching method and oil confirmation	15
4-2. Mounting method of the needle	16
4-3. Online linear thread method	17
4-4. The replacement process of the bobbin	18
4-5. Line tension adjustment method	19
4-6. Adjustment of the pick-up spring and the disconnection plate	20
4-7. Adjustment of the pick-up gap slip	20
4-8. The relationship between the needle and the hopper	21
4-9. The wire of the wire	23
4-10. Adjust the cutting position	24
4-11. The demolition method and installation method of the cylinder lift board	26
4-12. Confirmation method of shuttle oil (tub)	27
4-13. Tungs of the tucks	28
4-14. Adjust the pinhole and needle of the needle plate	29
4-15. Set the mechanical origin	30
4-16. Adjust the tray pressure pin pressure	31
4-17. Adjust the wire end port at the beginning of the sewing	32
4-18. Adjust the electronic section of the stage fetal	33
4-19. Adjust the silk air fan	34

4-20. Make the template.....	35
4-21. Sewing preparation.....	37
4-22. The name of the part of the panel.....	39
4-23. Maintenance mode.....	41
4-24. A list of parameters.....	42
4-25. Error coding list.....	47
5. Maintenance of sewing machine.....	61
5-1. Failure, reason and countermeasures when sewing.....	64
5-2. Battery waste.....	65

1. Specifications

1	Sewing range (x.y) (mm)	1300 × 850 (Cutting range rotation cutter specifications: 698× 391 laser specifications: 646.5× 426.5)
2	Pressing off the cloth	Intermittent feed (pulse motor baidiar drive)
3	Pinch stroke	39.5mm
4	Maximum sewing speed	3,000STI/min(Sewing pin 2.5mmThe following) About other content, refer to Figure 1
5	Can be set segment length	0.5 ~ 12.7mm
6	Use the needle	DB × 1 # 8 (# 7 ~ # 14), dp × 5# 8 (# 7~ # 14) Rely on model selection
7	Turpuring the ho	Total rotation of the hopper
8	Medium foot pressure	Standard 4mm
9	Medium-pressure footing up	20mm
10	The appliance pressure rolled ups	15mm
11	The memory of the data	Maximum 999 patterns
12	Identification of the number of patterns	Maximum 999 patterns
13	Procedure input mode	USB
14	Infrared form	Dxf.ai.plt.dst
15	Spindle servo motor power	750W
16	Consumption power	640VA
17	Input voltage	220V ± 10%
18	Quality (total quality)	Standard Specifications: 590kg Rotary Cutter Specifications: 598KG LaserSpecifications: 655.7kg
19	Dimensions	2,190mm (w) × 2,100mm (l)× 1,250mm (h)
20	Use the temperature range	5 ~ 35 °C[Laser specifications] 1 °C ~ 35 °C
21	Use the humidity range	35 ~ 85% (no condensed)[Laser specifications] 5% to 70%
22	Save the temperature range	-5 ~ 60 °C[Laser specification] -10 °C ~ 100 °C
23	Save the humidity range	20 ~ 85% (no condensation, 85% is 40 °C or less) [laser specifications] 20% ~ 85% (no condensed)
24	Use air pressure	0.5 ~0.6MPa
25	Needle on the needle barrier stop function	After sewing, the needle bar can be returned to the downstream dead position.
26	Use oil	# 10 (equivalent toJukiNewDefirixOilNo1), # 32 (equivalent to juki new deffin oil no2), lithium element 2 Grease information Manufacturer: United States Wenaball Model: Lithium group 2 # grease

Sewing pitch and sewing speed			
Numbering	Spacing	Sewing speed	Remarks
1	2.8 mm	2,500STI / min	
2	3.0 mm	2,500STI / min	
3	4.0 mm	2,000STI / min	
4	5.0 mm	2,000STI / min	

Note: The maximum number of rotation numbers shall not exceed 15 minutes. Even if the spacing is the same, the sewing

speed may occur due to the difference between the needle and the fabric.

Figure 1

-1-

2.Name of the part

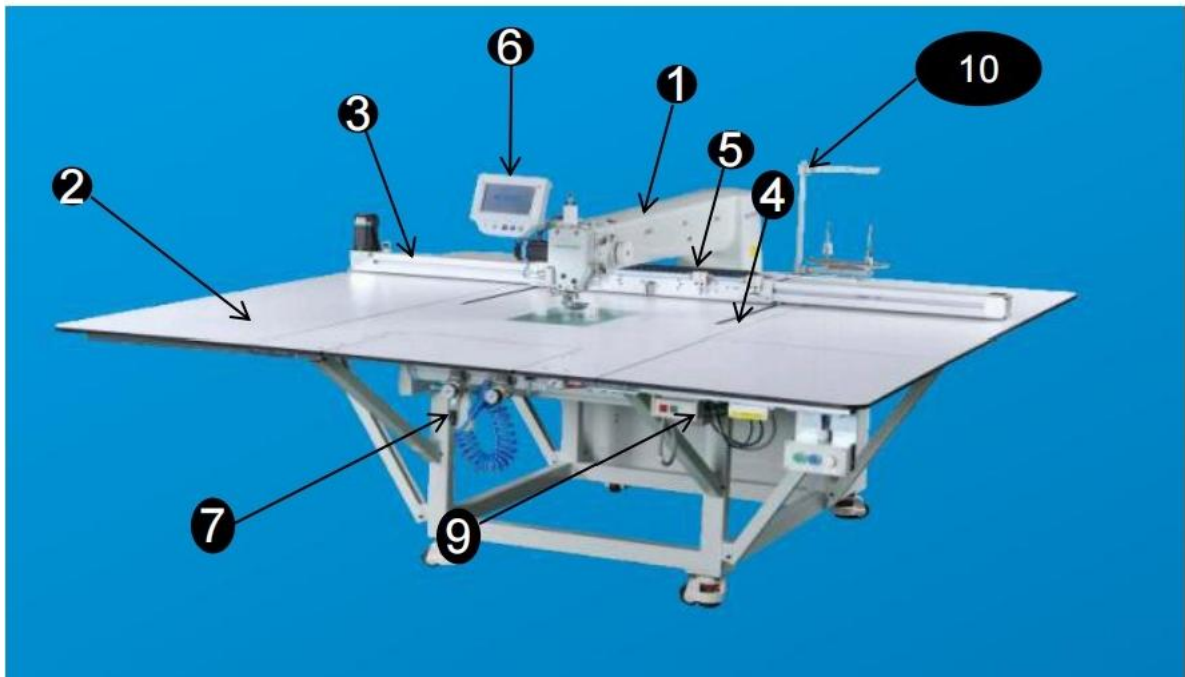

- 0 sewing machine head
- ②Table board
- ⑧XShaft conveyor mechanism
- ④YShaft conveyor mechanism
- 6 card holder
- 6 Operation panel
- ①Air control box
- 8 electrical control box
- 9 Power switch (ETHWWERATE EPROWING)
- ⑩Ribbon device
- ①Winding device

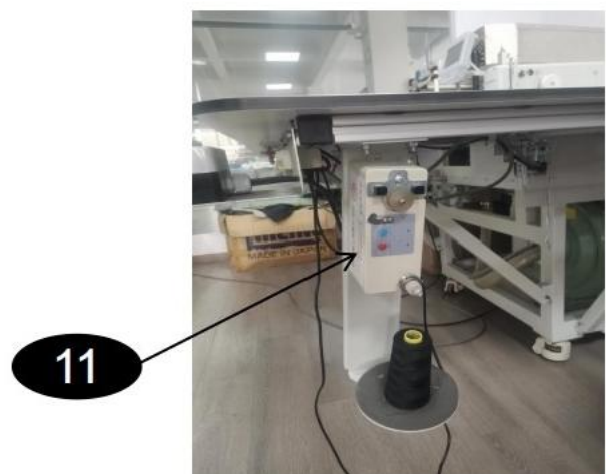
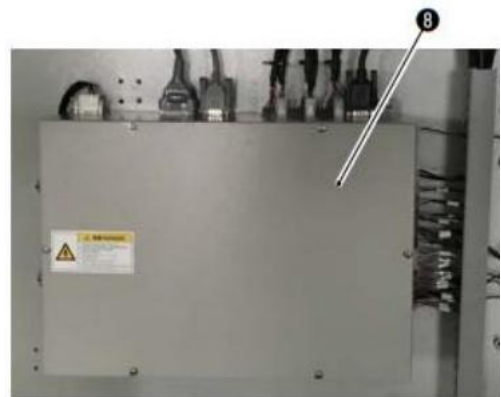

3TheAnnMachine

3-1. Installation of sewing machine

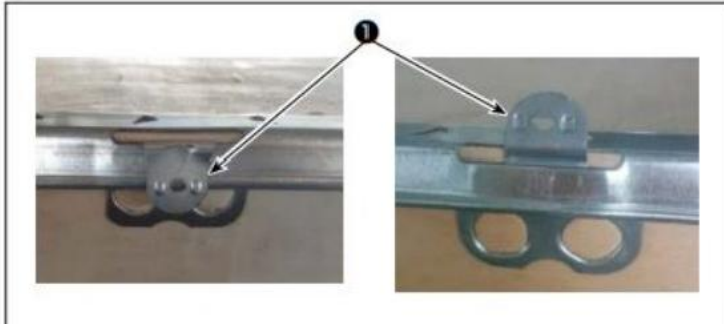

3-1-1. Remove the packaging

1) As shown, the dragon is ○
straight



If the clamping device is raised
or not sufficient, Removal will
be more difficult.



2) First, remove the top of the board②, In the demarcated wood.



4) Remove the plastic bag.



5) Remove the parts on the wood frame, the appendages and the feeding mechanism.



请将叉车插入此处。

6) Use the forklift to move the machine to the specified location. (The weight of the machine is 500KG)

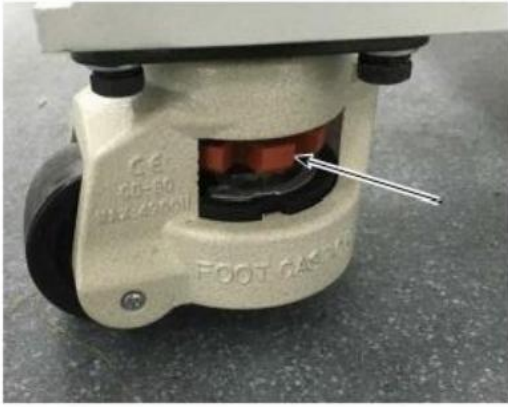

7) Rotate the adjustment knob of the support seat ③, Confirm the sewing machine The level of the level.
Let the machine are in a smaller state.

3-1-2.xThe installation of the feed

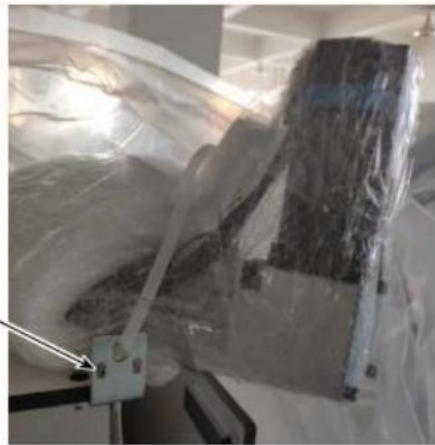

1) Remove the fixed sheet metal ①, the removed screws and the nut into the attachment box.



2) Remove the packaging.

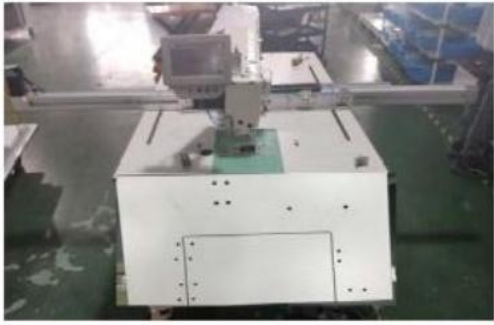

3) Will X The feed is turned on on the plate, the pressure frame device is shifted To move to Room.

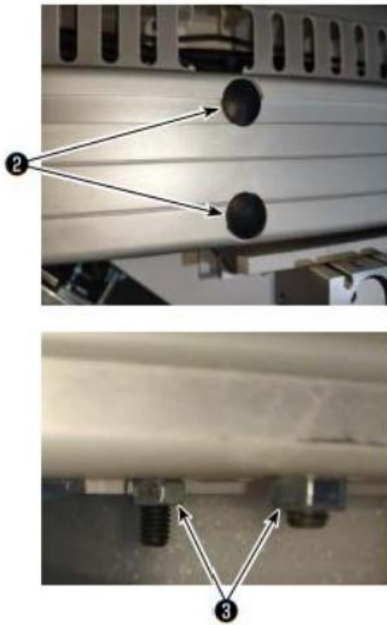

4) Remove the rubber thimbo ②, The four nuts on the bottom side with the wrench ⑧ demolition Under the following.

After the nut is removed, the screw does not remove from the mounting hole. The removed nut is placed in the attachment box.



5) to screw the screws andXThe screw hole on the feed support is aligned,Tighten the screws.

3-1-3. Table of the table

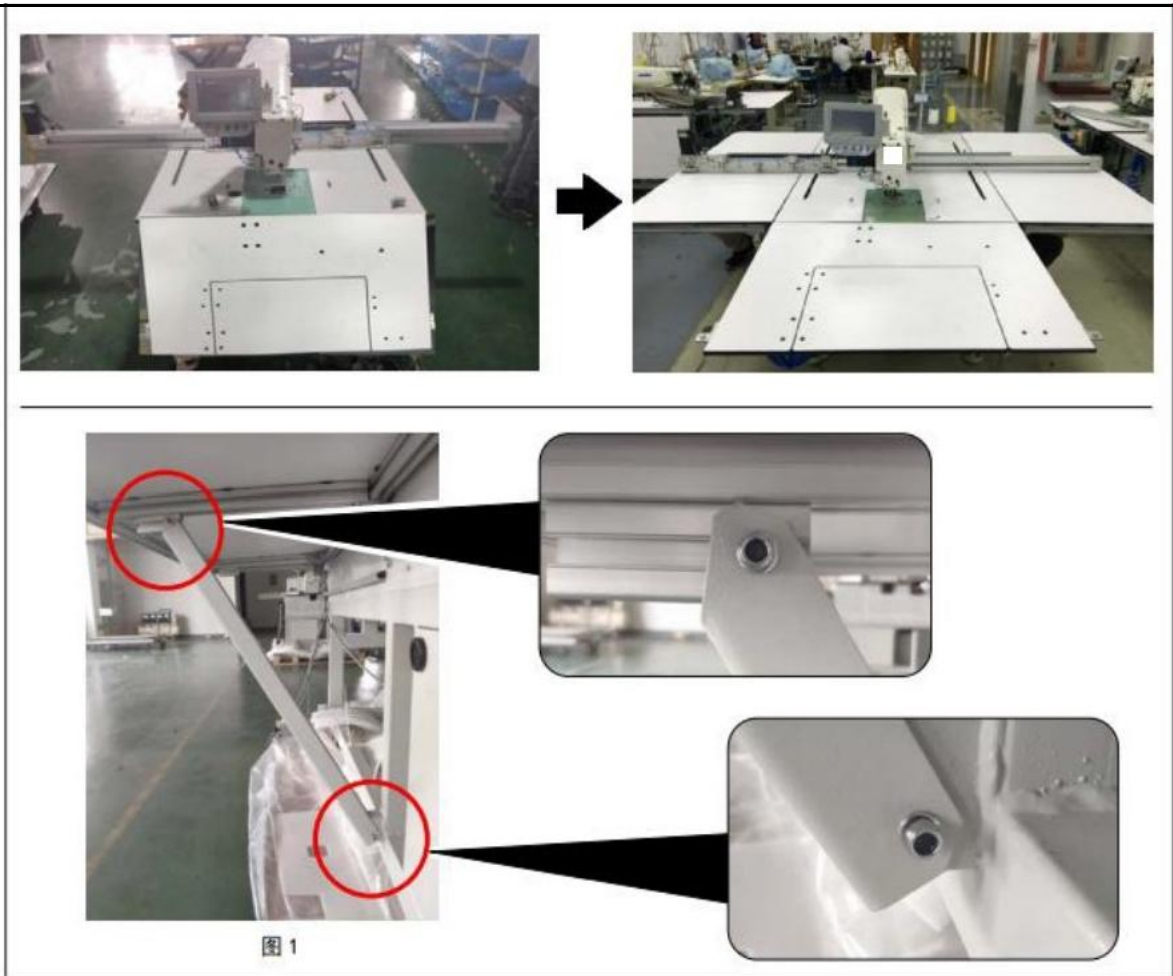

1) Install the left table, right table, and front desktop (in), follow the figure shown in Figure 6, tighten the screw.



2) Install the desktop (left) and the front desktop (right).
Each site is fixed with a dedicated connecting plate.

3-1-4. Installing the switch, the winding device and the switch button (group)

* Tools in the accessory.

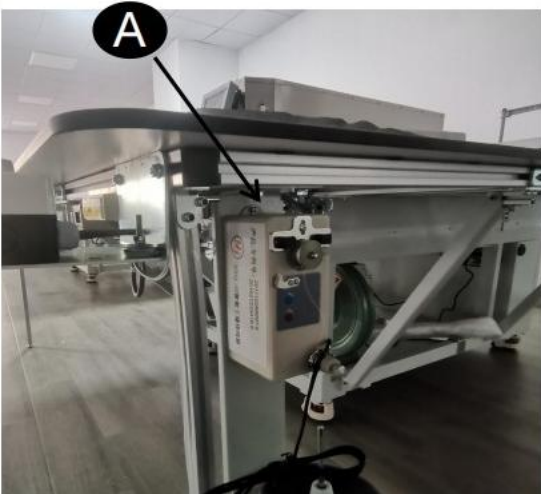

- 1) Turn the winding device with tScrew AFixed before Table of the table (right) on the aluminum frame.

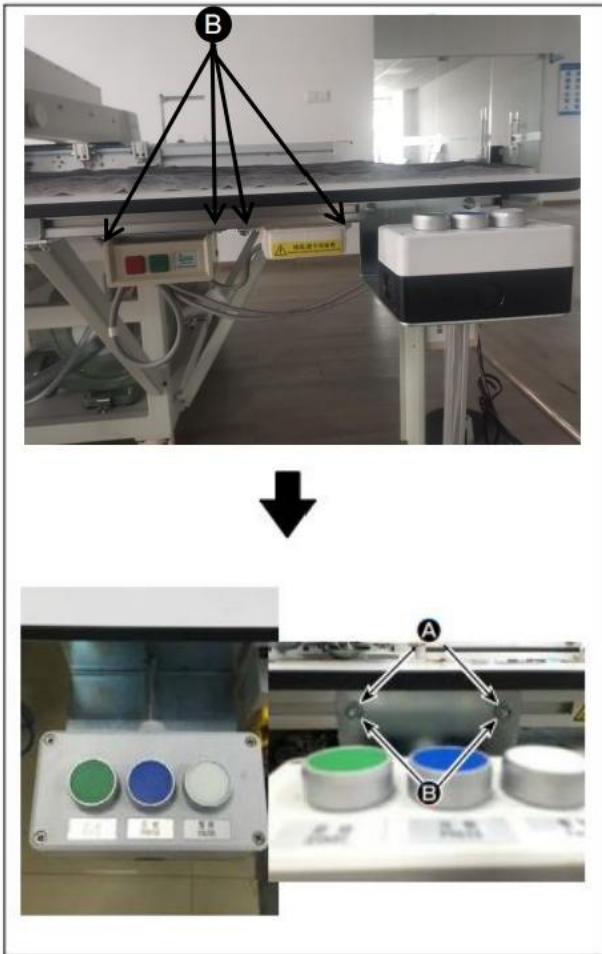

- 2) Through the screwsBFixed on the slider in the aluminum tank

- 3) switch button (group) © installation direction changes,

With tScrew Δ and nutsBFixed on the front desk (right)The aluminum frame.

The three switching ports are fixed to the state.

3-1-5. Open the inspection before and after the test

1) Check the level of the machine.



2) Check the installation of the machine appliance and air conditioner.

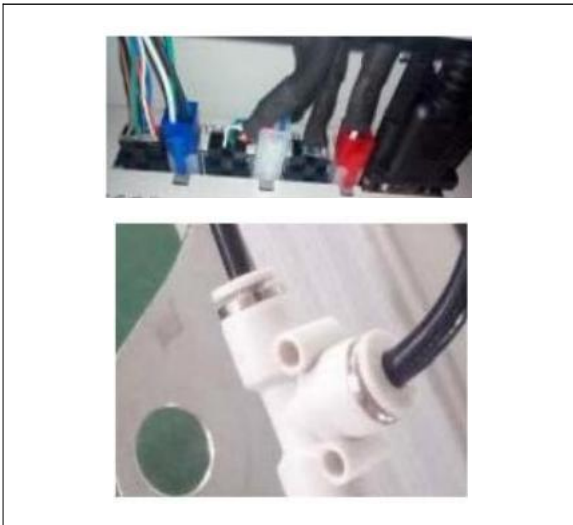

3) Check the alignment of the machine with the center of the needle hole.

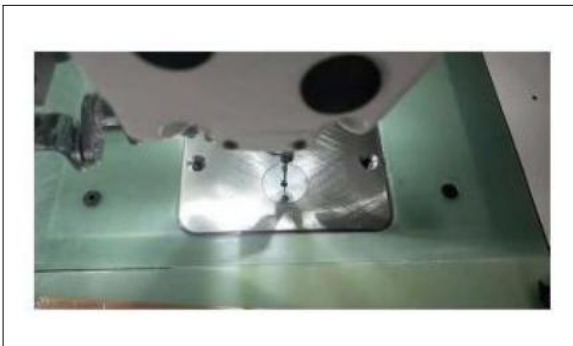



4) Remove the needle plate, check the need for the needle and the hook.

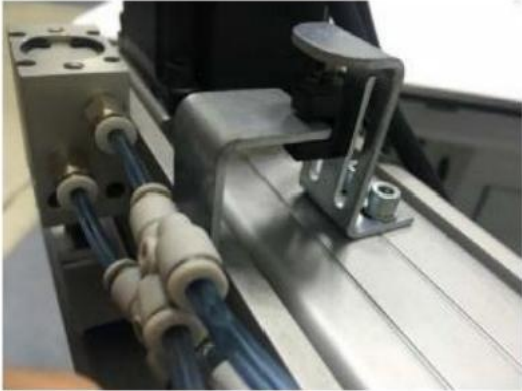

5) checkXThe origin of the feed detection sensor and the gap of the tab.



6) checkXFeeding the action.

3-2.空气软管的安装



In order to prevent air from blowing to the human body, before the machine supply air, please confirm whether the air hose is indeed inserted into the air palms, but then After the slow air opening.



- 1) air pipe piping
Connect the air hose to 0.



- 2) the pressure of air pressure
The air adjustment knob ② is pulled up and rotated and the air pressure Adjust to 0.5 to 0.55MPA
The air adjustment knob ③ is pulled up and rotated and the air pressure Adjust to 0.15MPA
And then press the air adjustment button ④.

②: Adjust the oversized air pressure of the sewing machine
③: regulate the pallet pressure foot air pressure

3-3.有关压缩空气源(空气供给源)设备的注意事项

90% of the failure of the air compressor (cylinder, air solenoid valve) is due to air quality "dirty air".

Compressed air, with moisture, dirty, deterioration of carbon particles and other vulnerable, but if notHow to use these "dirty air",There will be a failure, resulting in a reduction in the operating rate of the machine and affecting the production.

When setting the device using a air machine, make sure you use the following standard air source devices.

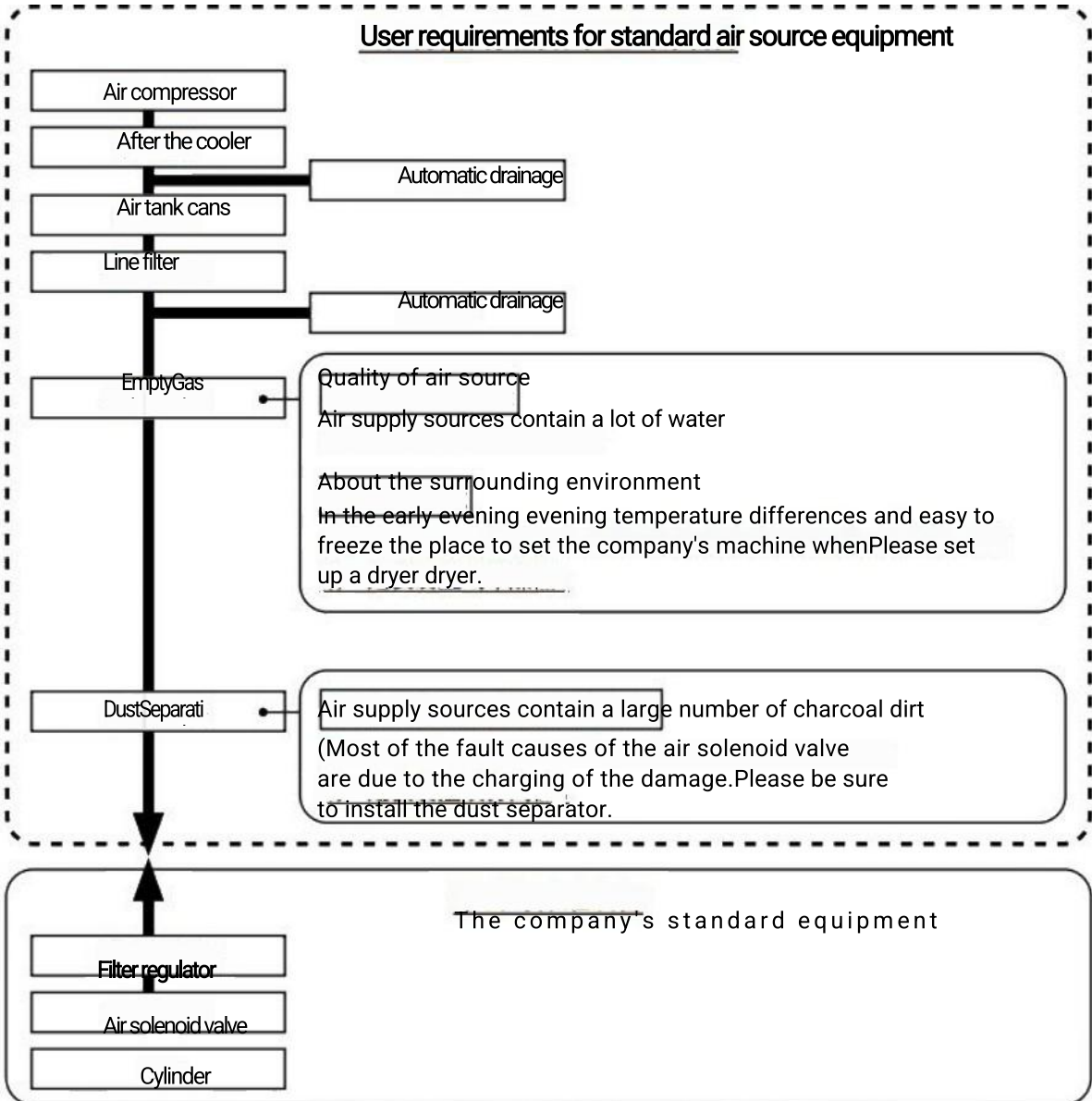

Maintenance of the precision of the mind

- Main pipe in average air force in air flowMS should set up 1cmThe downlinks.
- When the branch is installed from the master tube, the air-inlet of the compressed air is installed on the upper part of the pipe to prevent the condensate in the tubeOutflow.
- Install the drainage device (automatic drainage) at all low parts and dead to prevent condensingAccumulation.

3-4. Install the cylindrical device

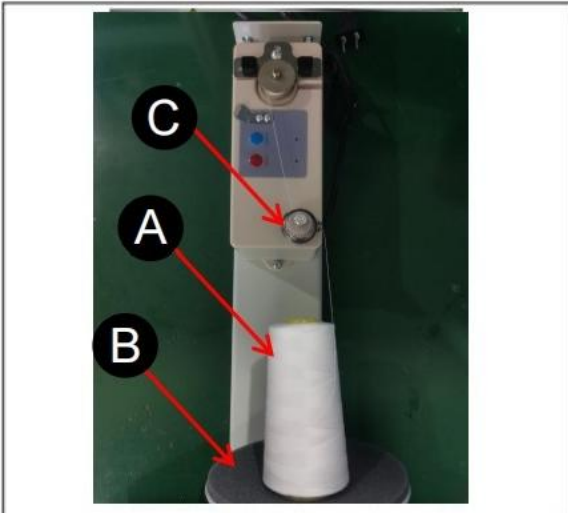

1) Will **A** Put into a **B** In passing **C**

3-5 The end Line Volume Wound around Party Method

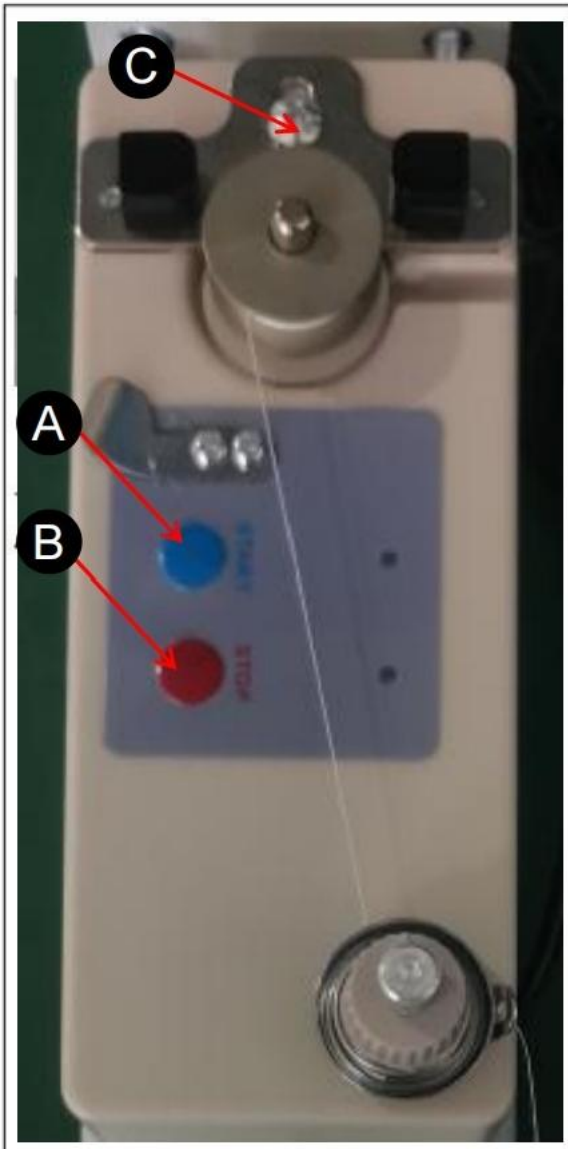

rt key **B** For the Pause key **C** For adjusting the lock Core

Wool volume

3-6. Note about mechanical settings

1. According to the size of the template, in X Direction it may be out of the sewing machine



Taiwan. Please pay attention to do not touch Invasive injury to the human body.

2. Make sure to open from the sewing machine

At the beginning, no matter about or before and after the whole There are more than 500mm The space.

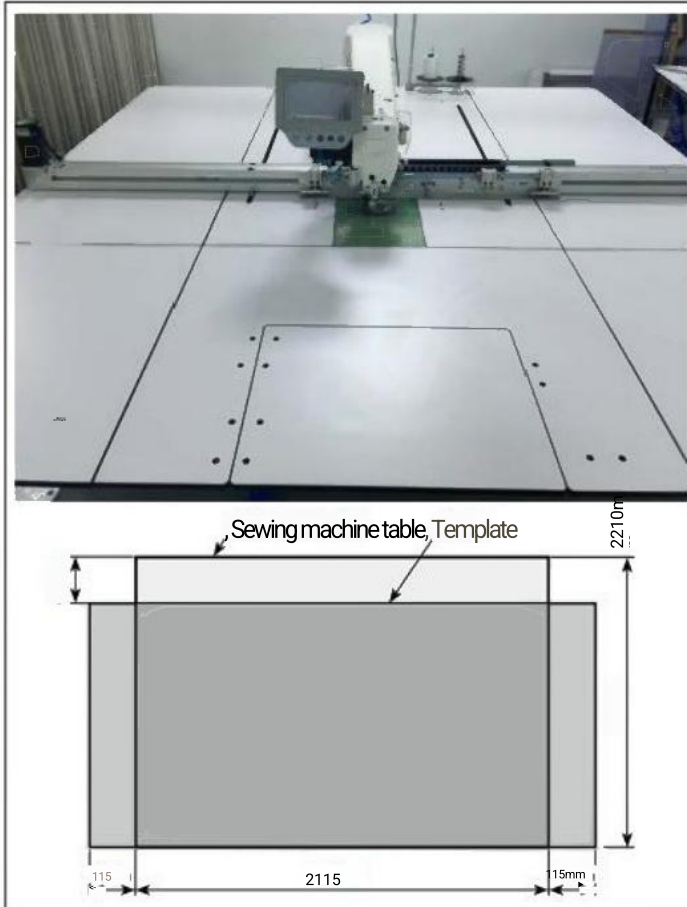

4.Preparation of sewing machine

4-1. Confirmation of oil refining method and oil

Warnin

In order to prevent sudden start to cause personal accidentPower and then proceed.

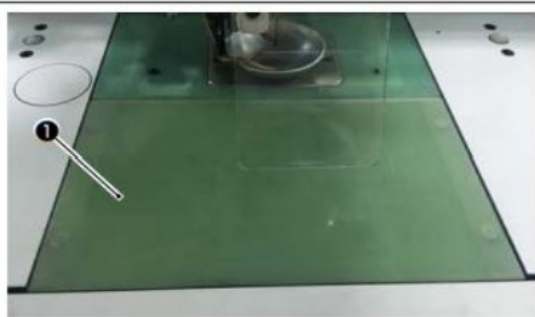

1) Remove the cylinder lift board ①.

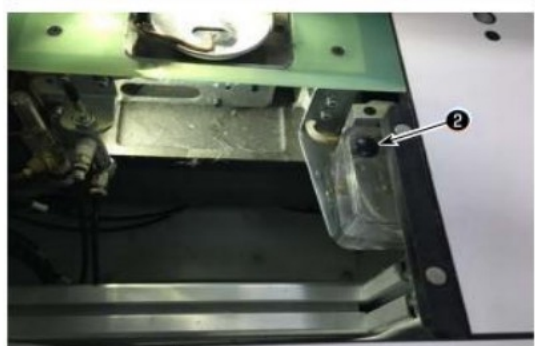

2) Remove the tank of the rubber thin.



3) Injection of affiliated lubricants (or specified lubricants).



4) tank tanksMinShow ~MaxThe display is betweenIn a reasonable oilThe amount of the amount.



1. Please do not use oil species for the pressed oil. In addition, After the oil is fully installed, the rubber and cylinder are firmly installed. Help the board.
2. When using the sewing machine for the first time, or when a time is not made. When using a sewing machine, please a small



Warning

In order to prevent sudden start to cause personal accident, turn off the power again.

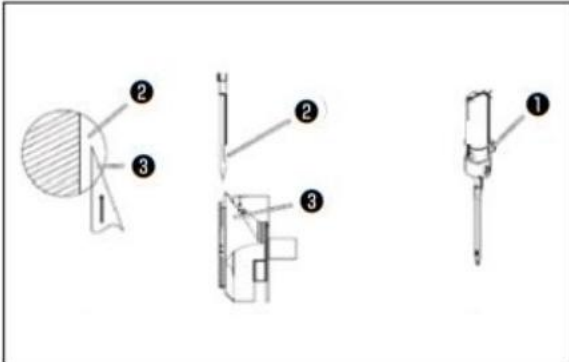

Loosen the screw ①, remove the needle.

Be sure to let the needle slots ② to the top ② of the rotary container Direction.

2) Tighten the screws ①.



If you want to replace to a different different needle, be sure to re-Adjust the distance between the rotary container and the needle. If forgetting it Adjustment, may be the following questions:

1. jumper
2. Silk loose
3. Top breakage of the container
4. Needle damage

4-3.上线的穿线方法

Warning In order to prevent sudden start to cause personal accident, turn off the power again.



1) Let the sewing machine wire inserted into the wire fixing device ②.

2) Through the figure to pass the filament.
Finally, pull up the top of the wire from the hole to 50 to 60mm

△ warning In order to prevent sudden start to cause personal accident, turn off the power again.

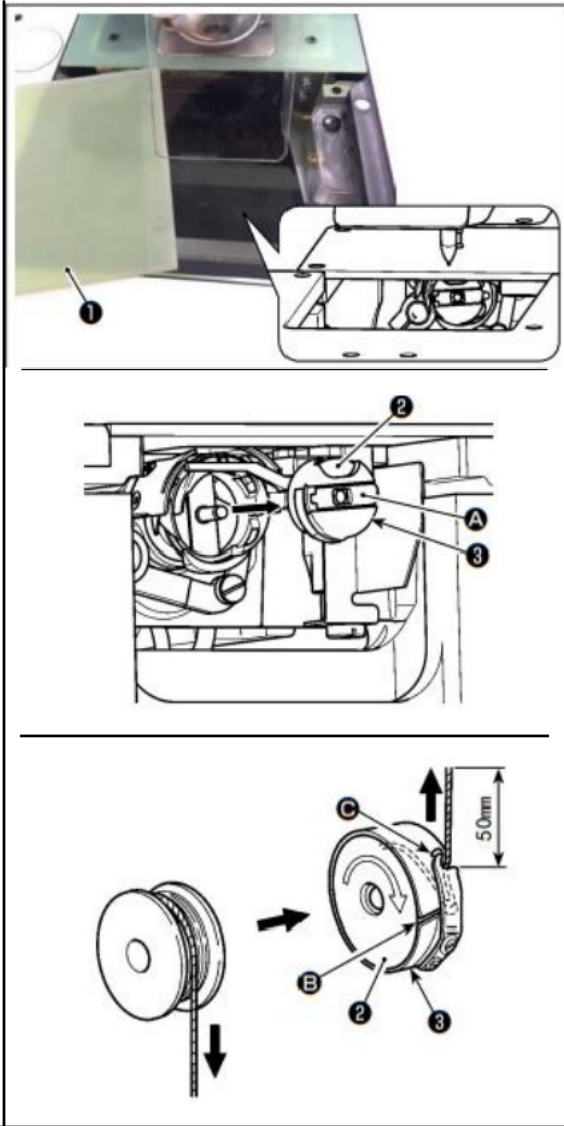

(1) shuttle shell removed

1) Open the cover plate ①, you can replace the bobbin.

out of the foot△, Take out the shuttle⑥ And the bobbin ②.

注意 Before opening the cover plate ① please confirm the hand or other items before Location, to prevent the shelf of the goods and caused personal injury. In addition, please do not put the hand on the cover ① to press.

(2) mounting of the body

1) Insert the core core in the direction of the insertion of the shuttle.

注意 Push the line through the shuttle shell ⑧ the line B, Then pull the line and put the line in the line tension spring below the wearer port ③ Pull out. 3) pull out 50mm The

The rotation direction of the core is the opposite direction, the bottom line pulls the instability Set up.

注意 When mounting mounting 1) putting, please put it back before A The state of the insertion into the shock

And issued a click of the sound. 2) to cover the cover ①.

If there is not inserted at the end, the shells on the shells have a Can be off.

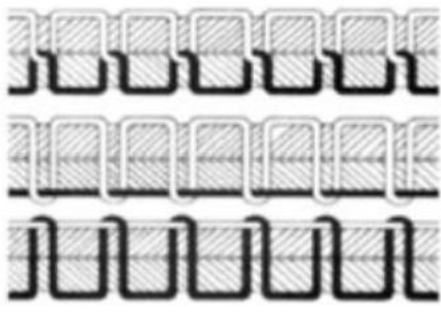
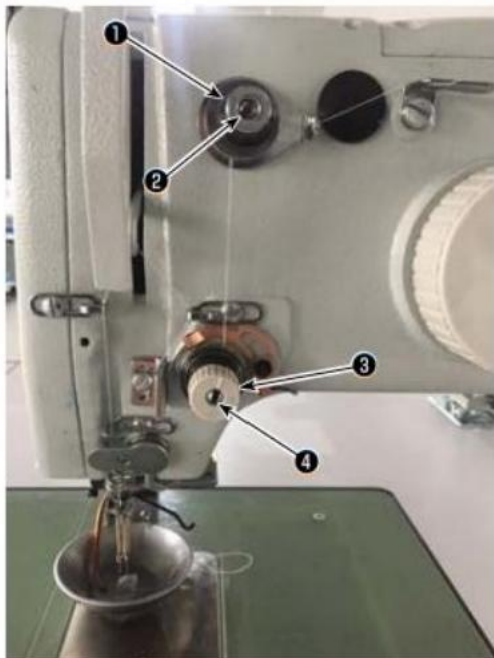

Figure A
Graphs B
Graphs C

(1) adjustment of the tension

When you are loosening the tension pallet of the second wire tension ②, it must be leave a little tension that can control the cutting wire. Rely on silicon tension. The lamp force produces the remaining tension. Can adjust the spirazzi of the spikeMother ②. After the automatic cutting, the decision is decorated with the pin end of the pin. The length of the unit. If the clockwise (+) rotating nuts ②, the row of the row of the pin. The extension

Second wire

About the tension of the second wire tension ⑧ (from the pin out of the silk Tension), as much as possible as low as possible, so that the silk in the fabric Central phase To be over (the figure A). The If the tension is too strong when the sewing thin fabric is too strong, Will cause the fabric to produce wrinkles or filaments.

If the clockwise (+) rotating nuts ④, the silk sheets are directed out Level will become bigger.

If counterclockwise (-) rotating nuts ④, the silk sheets are directed out Level will become small.

(2) the adjustment of the bottom line tension

1) to right Δ direction rotation line tension screw ⑥, then the bottom line Strength strong and to the left B The direction of the rotation, then the bottom line Force weak.

Recommended value: 25g On the right

If you make the spinning box in the state of the state, because of the self-weight Detected.

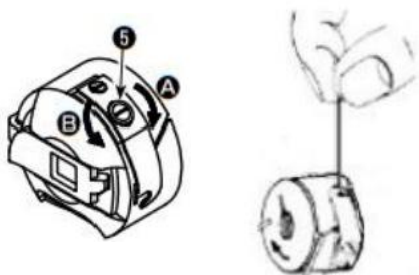

4-6.挑线弹簧和断线检测板的调整

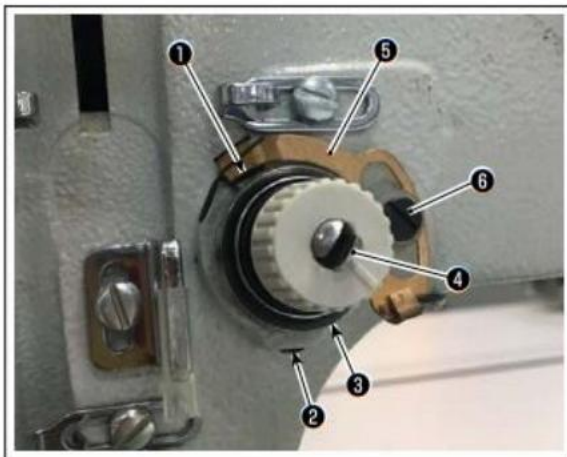

1) the adjustment of the itinerary

Loosen the fixed screw ②, rotating the tensioner ③. Turn to right to

After that, the tripation of the ball splice becomes larger, and the line volume becomes much.2) strength adjustment

Change the strength of the tilting springs ○, in the fixed screw②WatchIn the next state, the threading knife is inserted into the lack of the line tension ◎Mouth rotation adjustment. After rotating to the right, the balloon ○Strength becomes strong, turn to the left, the strength is weak.

3) adjustment of the disconnection plate

Loosen the fixed screw ⑥, adjust the location of disconnect plate ⑥,



the disconnect plate ⑥ and the pickup

spring ○ is the same amount of 0 ~

0.2mm:

Bread detection board ⑥ except slipper split ① can not be with themHe is part of the metal parts. Contact with other metal **In the case, an error occurred.**

4-7The Picks itLineRod Picks itLineQualityOf theToneWhile

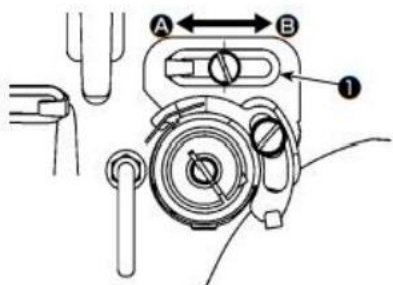

1) When the thickness is made, theADirection moving line guide①,Then pick

Line lot more.

2) When sewing the material, theBDirection movement line guide 0,The slip is less.

3) line guide ① is the center of the long hole to the center of the screws isStandard location.

△ warning In order to prevent sudden start to cause personal accident, turn off the power again.

(1) set the needle and container and angle

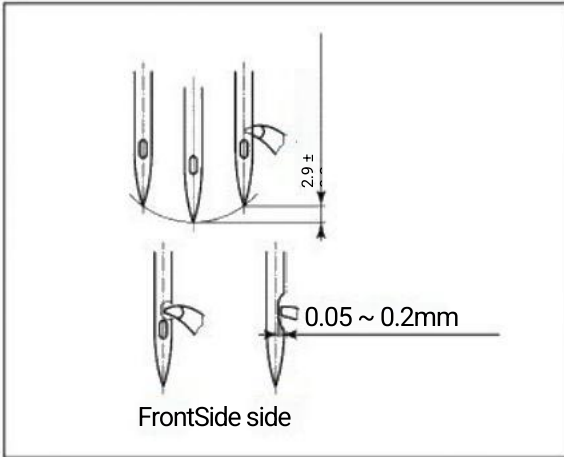

1) The dead point of the needle rose $2.9 \pm 0.3\text{mm}$, Pin on the needle

The height and adjust the relative position of the hopper.

2) from the front view to see the hip at the left side edge and the pinhole center coincidence.3) from the side view of the housing

g portion and the recesses of the needle gap is 0.05 to 0.2mm



After the break is broken, the time is bite into the shock. Please unsteadily Bite the line, then then sewing.



4) As shown in the figure, the angle of the electric axes QEP The value is displayed as 570 to 575.

(2) the position of the needle and the middle of the container presser foot

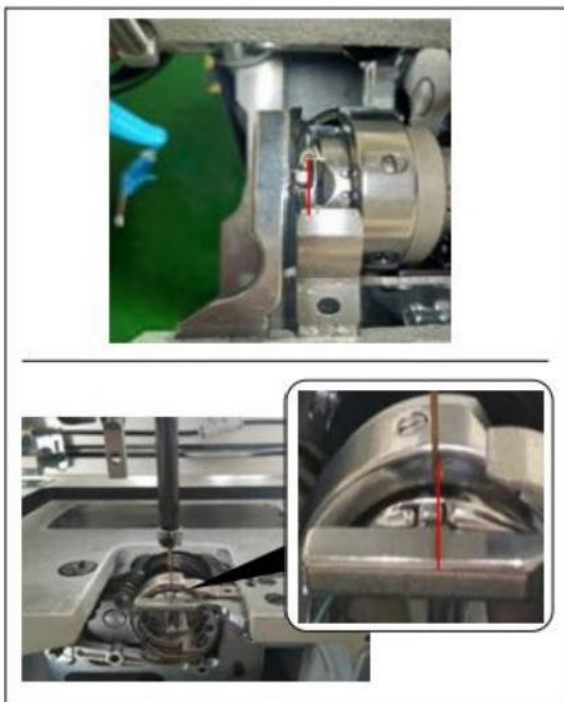

Middle Sand Container Pressure and Pore Front Rear Position: Front and Middle Container ForceQi.

Middle-containing container presser foot and pin left and right position: the middle of the container's protrusions The right end is aligned with the right hand.

(3) adjust the needle rod height

The high-speed of the needle rod Needle Bar Height

First, turn the handwheel to the minus point to the lowest point, (at the time of the needle rod and the needle bar on a line as shown in Figure 2) Wool blending 1 \ 2 (standard bit) Set) The Turn Needle Lowest, Take Up Link Align with Needle Bar, Adjust Needle Eye Align AS Picture (Standard)

Second, the low the low need of the needle rod depends on the fabric
1. Ordinary woven fabric two-layer structure, bench porosity Out of Soblin 1 \ 2
2. Knitted fabrics and structures are relatively thick, the needle hole exhibition of the blower 2 \ 32) Thick Mat 12/3 Eye
3. The difference of fabric, the sewing thickness is different, the needle bar is

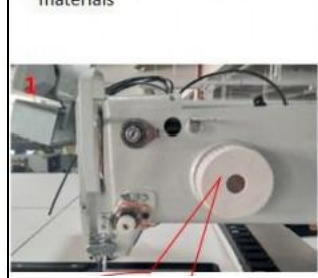

Handwheel, according to handwheel
Jane head rotation
Turn Hand Wheel
as Direction

turn the
handwheel to
the needle

Machine pores
exist to the

4
Needles
Essential oral
Pinhole

4-9. The wirefield method

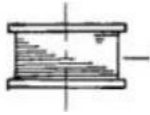

Tengma (80%) (recommended)

4-10.调节切丝位置

△ warning In order to prevent sudden start to cause personal accident, turn off the power again.



(1) adjust the position of the cylindrical cam

- 1) Rotate pulley ①, so that the cylindrical cam groove②And the roll wire rocketNeedle

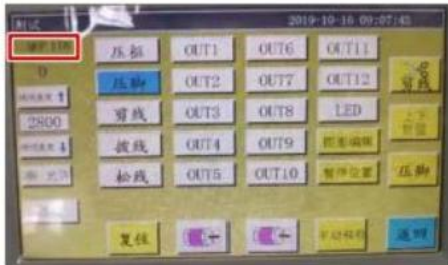

Angle setting the parameter on the electrical fixation axisQEPValue, 290 belongs toDelivery



(2) Adjust the position of the movable blade and the fixed blade

- 1) Move the movable blade in a movable blade table and hold the right to the rightBlade, so that movable blade tail and movable blade table parallel, thisWhen the head of the blade is similar to the knit. Tighten the movable blade tightenScrews ①.

Can beThe top of the



4-10.调节切丝位置





2) Install the fixed blade.

In the tail of the fixed blade with an empty, 2.5 hexagonal rod Wrench ② insert, so that the fixed blade tail alignment of the hexagonal wrench screw. Fasten the fixed



3) in the movable blade blade 5mm Use a black pen to make a mark so that Adjust the screws with a fixed blade pressure ② Adjust the fixed blade pressure. After adjusting, press the movable blade down and repeatedly adjust the straight To the two marks of the black mark at the same time accurately wipe. Otherwise.



4-11.气缸提升板的拆卸方法和安装方法



1) Press the switch 0 in the state where the sewing machine is turned on.

2) cylinder lift board② will be offset above, so should be removed. (GasCylinder for pressure)

3) When the installation of the cylinder lift board ②, press the switch①And installed.(GasThe cylinder falls in a state that can be installed, depending on the magnet fixed)

Warning

The hook is running at high speed. In order to prevent the accident, adjust the amount of oil, please pay attention.

(1) the confirmation method of oil (tub)

Oil (tub) confirm the special paper

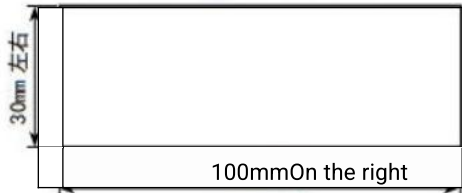

* Do not take into account the quality of the paper.

② oil (tub) confirmation location

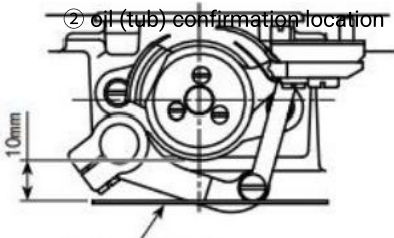

The track confirms the dedicated paper



When you perform the following operations, remove the upstream and shuttle cylinders from the pick-up rod to the needle to enhance the footsteps. After confirming the posture of the oil, please be sure to notice the need to let the hopper to the finger.

- 1) Please refer to please "4-1. Confirmation of oil refining methods and oil - P <150, To confirm whether the amount of oil is appropriate.
- 2) When the head is cooled, please turn on the oscillate plied operation for 15 minutes.
- 3) Please make sure the oil (tub) confirms when the sewing machine turns Private paper insert.
- 4) oil (tub) confirmation time for 10 seconds.

(2) oil (tub) suitable for standard

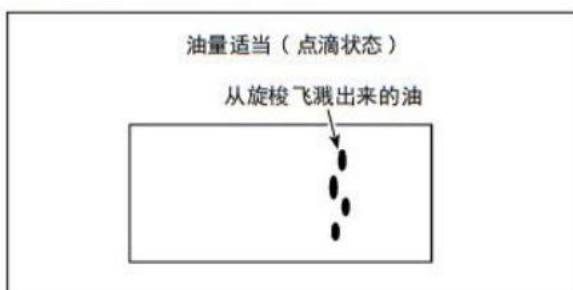

above-described illustration shows amount of oil (tub). 2) oil (tub) should confirm that three times are changed.

Please note that no oil increases the oil. Oil amount is too small Burning shock (shuttle heat), oil too much dirty Site.

 **warning** In order to prevent sudden start to cause personal accident, turn off the power again.

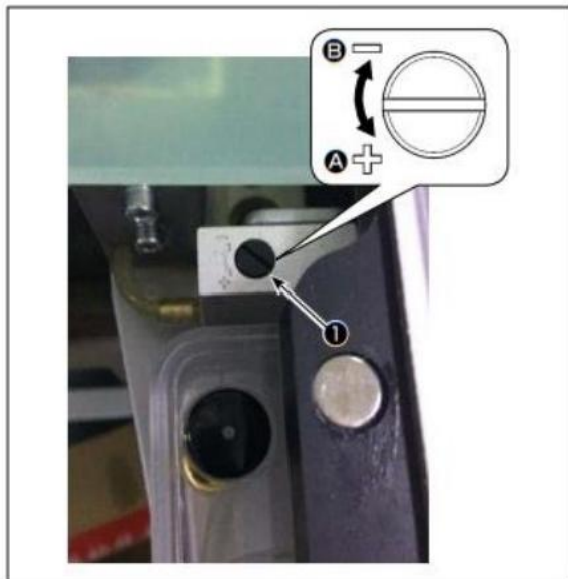

- 1) remove the cylinder lift board.
- 2) let the screws ① to the arrow A Direction rotation, oil will increase, to Arrows B Direction rotation, oil will be reduced.
- 3) After adjusting, install the cylinder lift board.



1. After adjustment, after the use of the sewing speed emitter to use for about 30 seconds, the measurement and the amount of the amount of oil are approved,

Confirm the amount of oil. (Reference "4-12. Turpostool oil (oil Confirmation method of Package "P.27)

2. When adjusting the shuttle of oil, adjust the amount of oil and then adjust the amount of oil.

3. Turnover oil shipment is adjusted according to the highest sewing speed, if the customer often uses low speed sewing speed, it may be due to

Capture of the shuttle is not failed, so often with low speed sewing speed When adjust, adjust the holes of the tuffle.

△ warning In order to prevent sudden start to cause personal accident, turn off the power again.



When the needle is not in the center of the needle pinhole, you can use screws ① for adjustment.

- 1) Remove the needle board.
- 2) Loosen the two needle pinholes to adjust the centrifugal screw ②, Mobile pin plate, Let the center position for the bench pinhole.
- 3) Tighten the needle pinhole with the centrifugal



4-15. 设定机械性原点

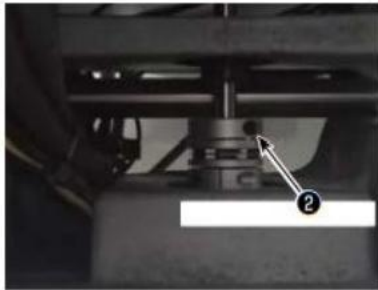

- 1) After slightly tighten the screws on the side of the lower side, rotate the pulley, Let the spindle motor side of the screw ① in the horizontal direction toward the.
- 2) Press the pulley, press the electric master screen
- 3) Once the machine configuration parameter is pressed, it is displayed. If the loseThe password 11111111 will appear 6.
- 4) On the picture shaft and display the screen, the QEP valueSet to 245, tighten the main axis side of the screw ①, released
A shaft side screw ②, rotating pulley, so that the needle rushes up to theDead.
- 5) Press the pulley (not moving needle stick), click the shaft of the picture setThe number ofQEPValue, after adjusting to 0, tighten the lower axis sideScrew ②.
- 6) To this point the adjustment is completed. Re-rotate the pulley if the needle stickThe upper dead point QEP value is 0, the original adjustment has no problem.

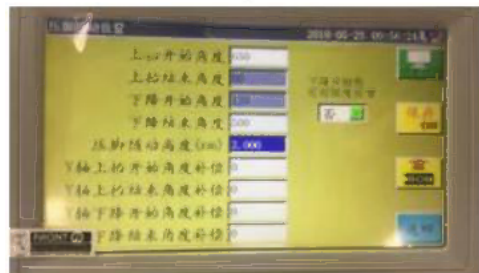
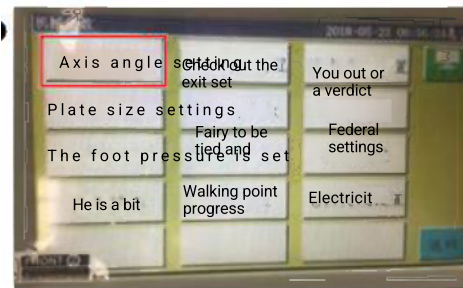

4-16. 调节托盘压脚压力



1) Adjust the tray pressure pocket pressure regulating valve. Raise the nuts ②, In the clockwise direction, the pressure will rise, if the pressThe time wheel rotates, the pressure will be reduced. Air pressureThe setting is set to 0.15MPaThe According to the actual situation of



2) Adjust the tray pressure cylinder above and below the pressing valve⑧And ④. Adjust the

3) replace the tray foot

According to the actual situation of the sewing, replace the tray pressure or pallet plastic

Pressure foot.

A Pallet pressed (installed when shipping)

B Tray plastic foot pressure

When replacing, adjust the adjustment and put the foot of the foot and container Full cover parallel. According to the actual fabric to adjust

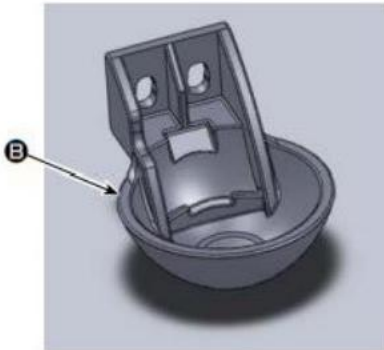

4-17. 调节缝纫开始时的丝端部位置

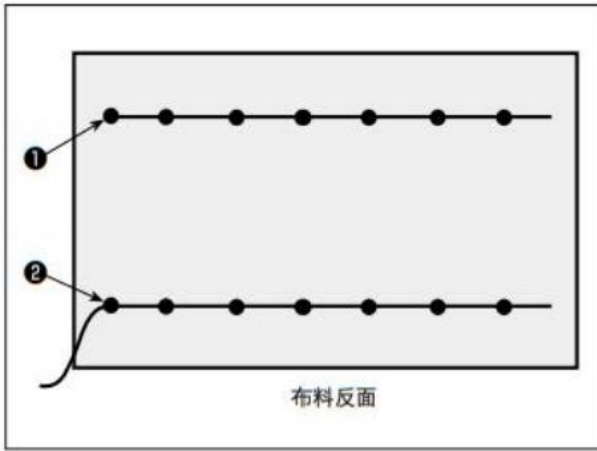

You can set the upper end of the upper end of the sewing to be in the fabricSide ①, or in the lower side of the cloth.

About these two conditions, switch the function of the functionON / OFFThe

① let the upper end of the fabric at the top of the fabricPlease let the dialing function are inOFFThe

②YIELDWhen the upper end of the wire is in the clothPlease let the dialing function are inOnThe

4-18. 调节电子中段压脚冲程

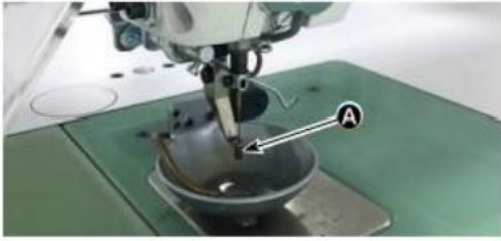

The feathers must be prevented because of the fabric thickness and fabricThe situation of the falling section (Δ) for the middle pressure foSection.

- 1) Press the power installation of the main master screen
- 2) If you press the mechanical parameter, it will show ② if the outputIn the

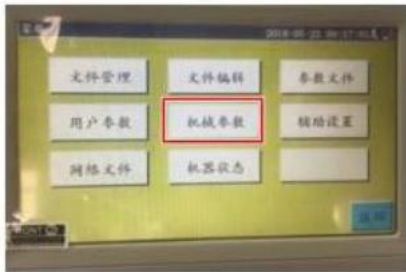

4-19. 调节上丝空气风扇



By controlling the solenoid valve of the electric shield, start at the beginning of the sewing. Blowing out of the pipeline ① blows out air, toward the tray foot ②. The bottom of the Blowing the silk end of the pin.

When the sewing starts, the wire end portion is pressed between the tray and foot pattern. Due to the impact of the pattern of the pattern and the direction of the direction, the wire ends can not be stored. When adjusting the direction of blowing and let it be pressed.

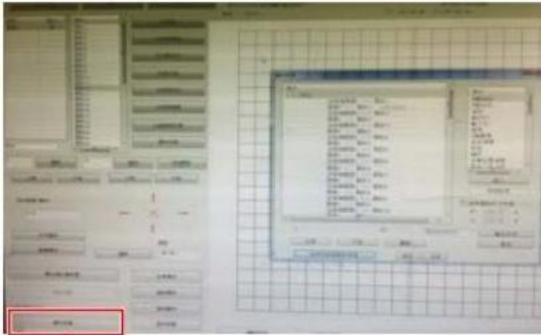

Start the pattern making software, handle the operation of the sewing pattern.

On the screen of the operation and then displayed on the screen, click ④ (the lit) Inward / 0), Will "1 / 0" Change to 5.

Change the "level" to high (low meaning OFF). Click on ⑥ (Yao Received, "Delay (C "s" to "225.

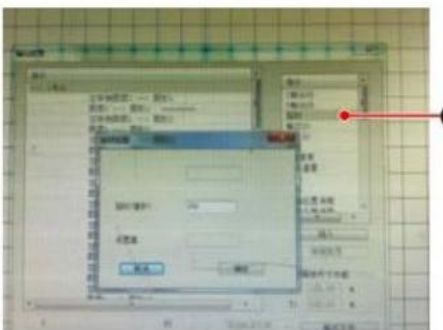

 **The silk air fan and the delay can not be used at the same time.**

1. The dial is to make the upper and more in the foot of the fan.

2. The silk air fan is to let the silk in the

4-20. Making template

(1) template processing

13085 model maximum sewing range size template

· Template material PVC Board

Template thickness is 1.5mm Of the PVC Board

· According to the sewing clothes and the pattern adjustment template size. Even the maximum, it can not exceed the maximum of the specifications Size. According to the complexity of the pattern, from 6 to 8mm Select the sewing tank.

The trajectory of the sewing tank in the template is designed according to the sewing pattern and the processing.

Choose the appropriate pattern engraving machine, by the trial of the technical personnel Processing.

After the upper and lower templates processing, remove the temple with the burrs on the mounting board.

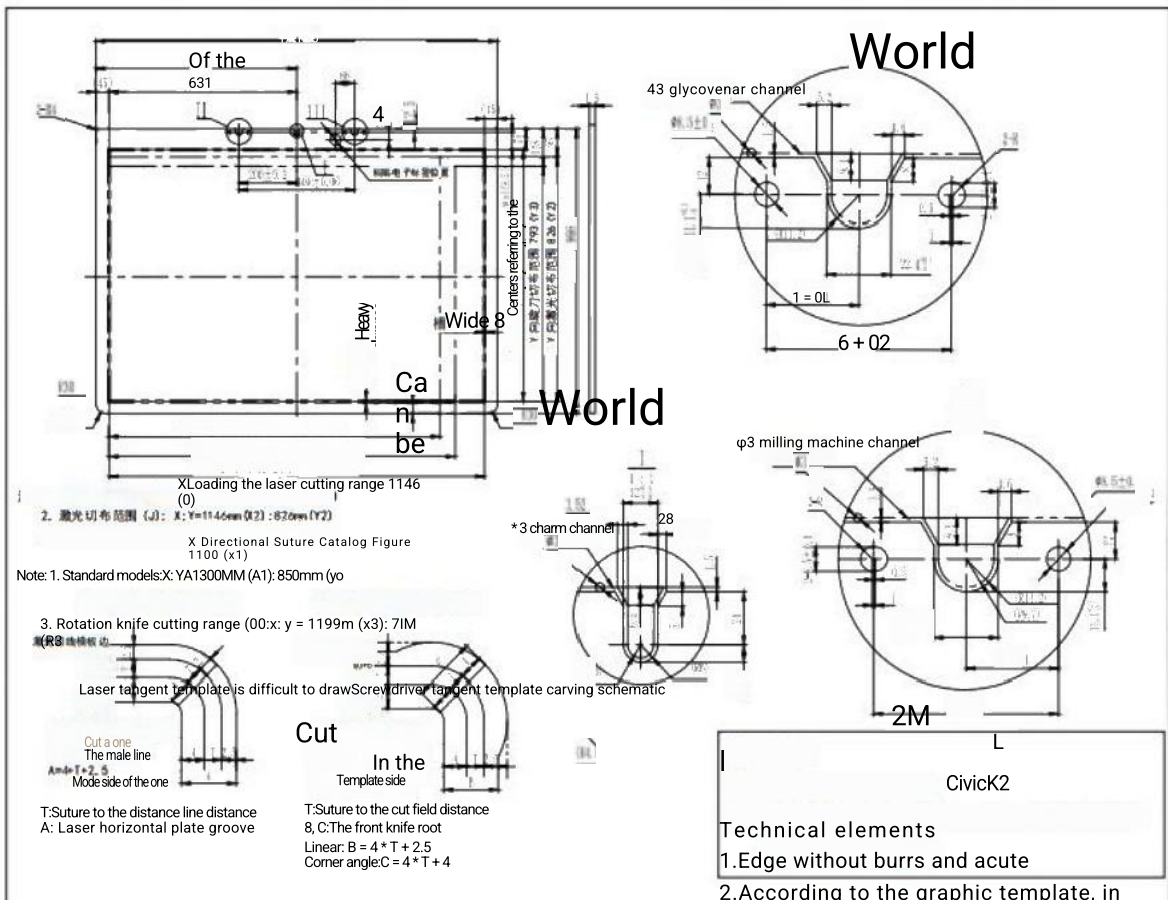

Technical elements

1. Edge without burrs and acute

2. According to the graphic template, in 6 to 10mm Between the decisions of the groove Width. Usually 8 for 8mm The

(2) installation template

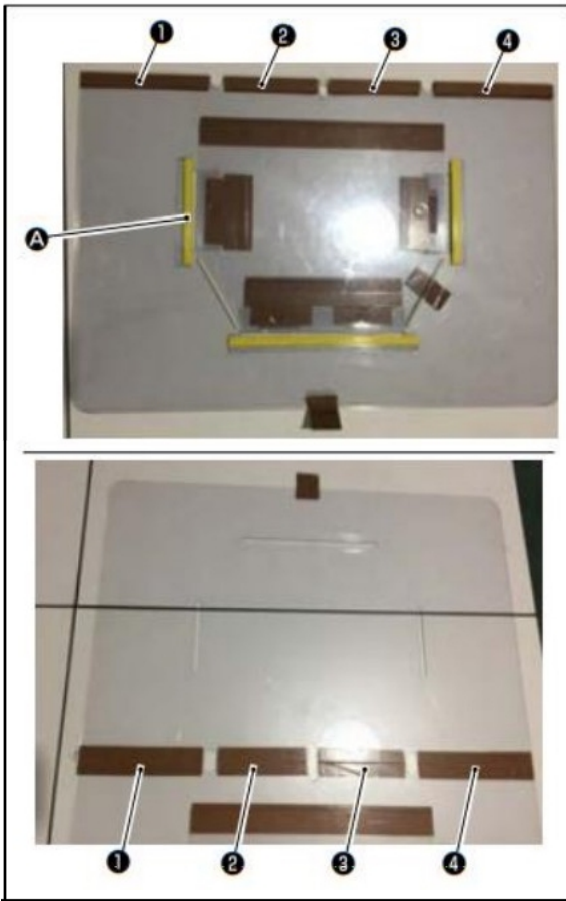

According to the design, processing templates and lower templates.

- 1) as shown in the figure, place the upper template above the lower template. The segment of the lower template is aligned overlapped.

As shown in the figures, in D, ②, ③ and ④ part of the stick template template with tape (width 36mm) The

- 2) Putting the slot in the slot of the upper and lower templates. Pad, Double-sided adhesive, or in the appropriate position plugged with the positioning needle, in this Decision of fabric position, firmly fixed, so that sewing seam is more Global.

4-21. 缝纫准备

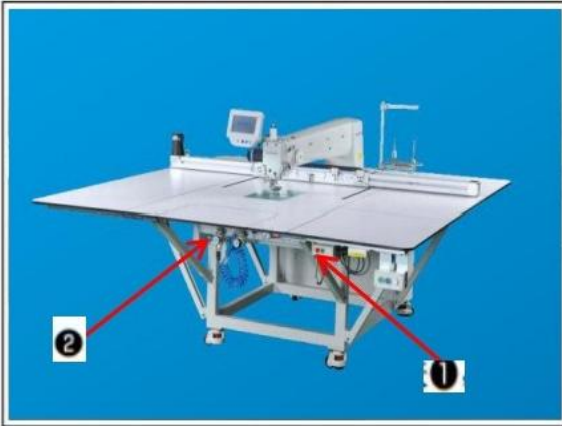

- 1) Open the main power switch
Press the **Open Import**, 打开 打开 打开 打开 ①
① ① ① ①
- 2) Open the main air source switch
Move the main air pump for left and right ②, Open the primary air source.



- 3) the reset of the device
If you press **Reset**, Let the device reset, the need to stop in
On the stop position, the tray foot pressure and the intermediate pressure will increase.

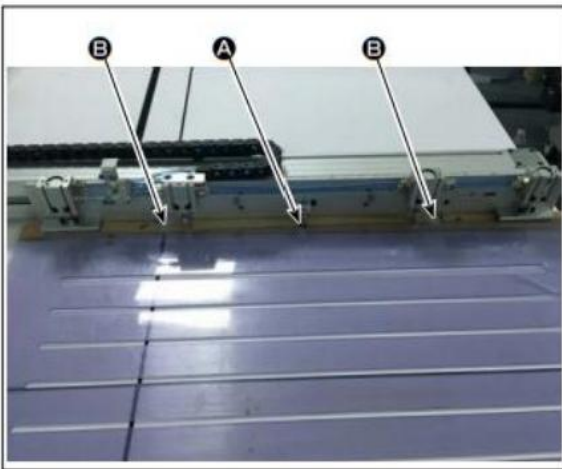

- 4) can be read by reading the pattern of wipes that wipe the sewing, or pass Operation panel directly edit the pattern data.
For details, please visit the electronic control system instructions.

- 5) Install the pattern
Let the empty pattern (not found in the fabric) move the movement of the pattern The position positioning hole on the positioning plate is hung on the positioning pin. Other two auxiliary positioning holes B Hanging position positioning slider Up and press to the bottom.

6) read the sewing pattern data

1. If it comes with a pattern on the pattern IC Card, the electronic scanning is started on the operation screen (see the number of references. Rely on electric installation automatic identification IC The match on the card sewing pattern.
2. If the pattern is not attached IC Card, the manual selection of the sewing pattern matching the pattern

4-21.縫紉准备

on the operation screenAccording to the

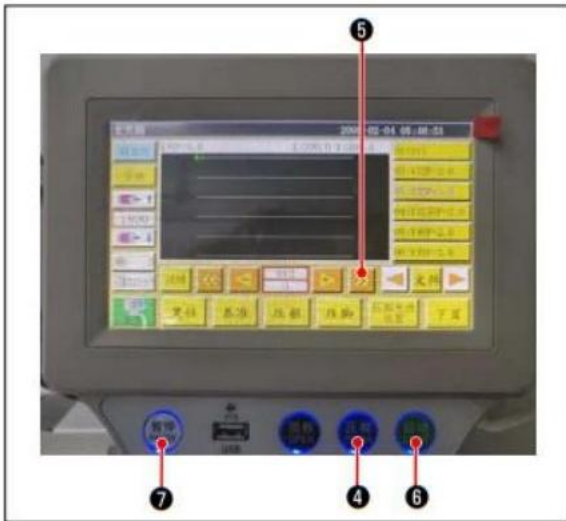

7) the choice of benchmark

In order to let the trajectory of the sewing pattern and the slot of the pattern alignment, must Set the benchmark, alignment. Specific matters according to the electricity system The scan operation is made of reference.

Enter the operation screen after the set reference. Press the button ⑥, The trajectory of the pattern is analyzed.

To run once, to confirm the trajectory and pattern of the sewing pattern Whether the groove is aligned. If no alignment is re-adjustable.

In the simulation run, when the run is running, press the button ②, Stop simulation run.

8) Upload sewing fabric

1. Remove the pattern

Let the pattern move to reset positions, press the clamp button on the operation panel, at this time, XT two cylinders on the linear module Placement, so the patterns should be taken out.

2. Upload fabric

The sewing fabric is uploaded on the pattern. When you are uploading, it should be confirmed whether the fabric is flat. In addition, rely on the compression method of the compliance pattern Press the cloth to prevent cloth to move. If there is a feather or cotton fabric, should be as much as possible in the air.

9) Set the reset, upload the pattern of the fabric, the reference

- Reset the steps according to 3).
- The process of loading the fabric is processed in step steps 5.
- Set the reference to the steps of 7).

10) start

Press the start button of the operator panel, ie, began to sew, will enter Automatic sewing mode.

11) Temporary stop

When the fault occurs, press the temporary stop button of the operator panel to stop running.

12) Restart

After the above troubleshooting, the temporary stop button ② is rotated. The button will promote and emergency stop mode The lifetime is released at this time if the press Start button ⑥, Will resume automatic sewing.

4-22.面板各部分的名称



A	Touch screen, liquid crystal display section	
Day	Pause key	Let the sewing temporary stop
O	Open key	Let the cylinder lift board up and down
⊙	Press key	Let the cartoon footsteps on the upper and lower movement
B	Start key	Start sewing
P	USBPort	



ⓐ	Reset button	Restart the panel
ⓑ	ComPort	RS232C

* This product does not have toWi-FiFunction.

The screen description of the panel

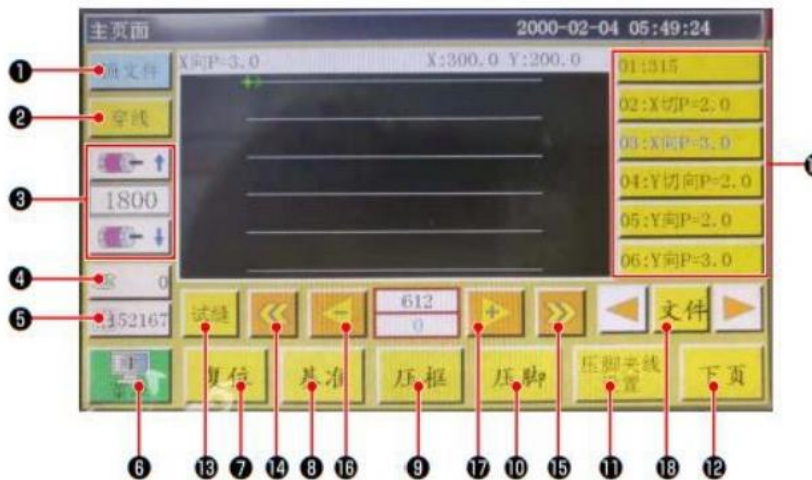

	Button, display	Contents
①	Lock key	Lock the sewing pattern.
②	Way to the wire	Let the silk by passing
⑧	Spindle speed change key	Change the spindle speed of the sewing machine.
4	Underline Utilization Key	Move the display of the wire feed usage and the screening screen.* 1
6	Sewing count key	Move to the display of the sewing count and the screening screen.* 1
6	Menu	Move to the menu screen.* 1
7	Preparation key	The origin reset of the sewing machine.
8	Benching key	Move to the reference setting screen.* 1
⑨	Dark box footer key	Let the cartoon press key action.
⑩	Pressure key	Let the foot press key.
①	Press the key setting key	Move to the presser setting screen.* 1
We	Page mobile key	Move to the test mode screen.* 1
B	Test key	Rely on the empty so that the sewing pattern is operated.
⑩	Line division reset key	Space to a previous continuous sewing start position.
D	Line dividing the key	Space to a previous continuous sewing start position.
⑩	Single needle reset key	Volume to be before the needle. If you continue to touch, will be faded.
①	Single needle delivery key	Volume to be before the needle. If you continue to touch, will be faded.
D	File key	Move to the sewing pattern selection screen.
	Select the sewing mode	Touch and select the sewing pattern used.

* 1 For details, please visit the Operator Panel Manual.

4-23.维护模式

The so-called maintenance mode refers to the extension of the sewing machine life, in the time to reach the period they must be done. Know the pattern. In the maintenance screen will be displayed on the panel. When the maintenance personnel is entered after the user password, the screen will disappear.



35;

- 1) The maintenance screen is displayed during the period where you must maintain. (About 3About or left or so

If you press the cancel button, Will return to the sewing screen. If itAfter 1 hour, the maintenance screen will be redist.



- 2) once preceding the buttonBack,if you have set the user with the firstCode, the user password input screen will be displayed.

3) Reference "5. Maintenance of sewing machineP.61,Apply grease.



- 4) Once the user password is entered, it will return to the sewing screen.

4-24. 参数一览

Parameter classification	Parameter name	Scope	Standard value	The meaning and comments of parameters	
Automatic processing	P1	After the automatic processing is complete, open the clampTight device.	Yes/ No	Yes	Continuous sewing ends 1 times to improve the cartridge clampDevice
	P2	End of the pressure pre-pin	0 ~ 8	2	Sewing start and sewing end of the intermediate pressure foot pressNext needle
	P3	After the automatic processing is completely cut	Yes/ No	Yes	Continuous sewing ends 1 times to cut wire
	P4	Automatic processing is complete after resetting the location	Original / secondary originalPoint	Origin	"Original" is absolute coordinate origin
					Whether the wire is loose in the space
	P5	Automatic processing is complete after resetting the location	Yes/ No	No	When the space is sent, the wire is open
	P173	Set the base bear	Yes/ No	No	Set the reference to the clamping footer On the "Main screen", when moving the shaft, pleaseKeep the state of the pressure. (Lift or down) OffIn the "main screen", the panel starts after the startPicture.
	P259	Operation of automatic clamping device	Yes/ No	No	Whether the seat is japonially set to the device
	P240	Manual delivery before the clamping device	Yes/ No	No	When you perform a manual conveyance, it is first lettingCartridge clamping device ON
	P6	Start the sewing repetitive number	OFF / 1/2	OFF	About "1" and "2" are, when the start is startedRepeat 1 to 2 or 2 for the initial pin position Slim sewing and then carry out the next needle positionSurface. Sets the number of pours for sewing start
					"OFF" Do not repeat sewing
	P7	Start sewing the release of the number of pins	0 ~ 255	0	The cloth is closed during the start of the sewing settingLoosen the device.
	P147	Sewing start pressure presser feet	0 ~ 4	0.5	The segment pressure height of the sewing start
	P148	Sewing end presser foot drop height	0 ~ 4	0.5	The segment pressure height at the end of the sewing
P161	Set the end pressure foot wild width	Normal / cutting oneSemi-semi/AddAdd	Normal		
P172	Reset the foot after rear of the operation	Yes/ No	Yes	The segment pressed the footer reset the sewing end	
P248	Is there a shaft before setting the base	Yes / no	Yes		

4-24.参数一览

	P252	Set the jaws when the reference beamError	Yes / no	No	
	P794	Operation end output 101	Yes / no	No	
	P796		High / Low	Low	
	P795	Operation End Output I02	Yes / no	No	
	P797		High / Low	Low	

Parameter classification		Parameter name	Scope	Standard value	The meaning and comments of parameters
Start sewing speed	P8	The first needle start speed (r /min)	100~3000	300	The first speed of the first
	P9	The second needle start speed (R /min)	100~3000	600	The speed of the second needle
	P10	The third pin start start rate (r /min)	100 ~3000	900	The speed of the third pin
	P11	Step 4 - needle start speed (r /min)	100 ~3000	1500	The speed of the fourth needle
	P12	The 5th needle start speed (R /min)	100~3000	2100	The speed of the fifth pin
	P170	Plotting rotation speed (r /min)	100 ~ 3000	1200	The speed of the dive
	P13	Whether it is open	Yes/ No	Yes	Is it a low speed
	P162	Is it beginning to sewing 2 needle low speed	Yes/ No	No	Is the second needle for a low speed
	P163	Is the sewing end 2 2 pin low speed	Yes/ No	No	The last two steps are slower
Speed parameter	P14	The maximum rotation number of the spindle (r /min)	100~ 3000	3000	The maximum rotation of the spindle
	P15	Air delivery speed(mm/min)	100~ 40000	35000	The speed of the space
	P16	Conveyance speed velocity (mm/min)	100~ 20000	5000	Fixed and the movement speed when making the pattern
	P160	The speed of the test sewing(mm/min)	100~ 60000	8000	Demo Speed
	P17	Button speed 1 (mm / min)	100 ~20000	500	Rely on manual move control box, collection of files,Copies in the 8 directions keys
					▶GraphsThe action speed of the standard
	P18	Button speed 2 (mm / min)	100~ 20000	1500	Copying 8 directions keys
					▶▶The speed of the action in the icon
	P19	Button speed 3 (mm / min)	100 ~20000	8000	Copying 8 directions keys
					▶▶The speed of the action in the icon
	P174	Head 2 speed(mm/ s)	0 ~ 2000	0	The speed of the XY axis when using a laser blade
	P175	Head 3 speed(mm/ s)	0 ~ 2000	0	The speed of the XY axis when using a laser blade
	P178	Continuous dynamic speed	ReduceLittle less/The mostSmall/Normal	Reduce	The movement speed when making a pattern
	P773	Reverse speed (r /min)	0 ~ 3000	0	The speed of the dive
P774	Sewing end of the speed limit of the number of pins	0 to 30	0	After the end of the graph, the first time from the last beginningThe speed of the needle is limited.	
P775	Segment end speed limit speed	100~ 1800	0	This parameter is used with P774 to be able to getSpecific limit speed value.	
Set the clampDe	P22	The sewing is prohibited when the clamping device rises	Yes/ No	Yes	The dark box box clamping device is ignored when sewing

vice	P25	Sewing starts the gray start angle	1 to 990	10	Sewing start of the grass on the angle
	P26	Sewing starts the width end angle	1 to 990	10	Sewing start of the grasight angle
	P27	Crossing the width of the start angle	1 to 990	15	Cross the widening angle of the wipe
	P28	Crossing the width of the angle	1 to 990	180	Cross the width of the width angle
	P781	A clamping device is required when moving	Yes / no	No	
	P743	The double clamping device opens the delayMS)	0~ 5000	0	
	P744	Double clamping device decline delayMS)	0 ~ 5000	0	
Set the curve	p29	Cylindrical state	License / prohibition	License	Cue wire deviceAllow
					Default state
	P30	Cue speed velocity (r /min)	100~4500	2200	Cylindrical speed
	P31	Set the rubic time (s)	1 to 63000	200	Set the rise time

Parameter classification		Parameter name	Scope	Standard value	The meaning and comments of parameters
Set reset	P30	When the reset is clamped	Yes/ No	No	When the origin is reset, the cartridge clamping device drops
	P264	Open the clamping device after manual reset	Yes/ No	Yes	Press the reset button, the origin is reset, the cartridgeThe clamping device rises
	P38	Original reset mode	XY at the same time / x excellentFirst/YSuchFirst	XY at the same time	"XYAt the same time "mean the beginning of the original pointSet, "X priority" means that the X-axis originally originally originallyPoint reset, then the Y-axis is replaced by the origin.
	P39	Original reset speed(mmm/min)	100 ~ 60000	15000	When the origin is resetXYShaft speed
	P756-P761	Set the output 10 before reset	Out1 ~ OUT6 /No	No	Set the reset before 10
	P762-P767		High levels of low waterFlat	High level	
	P649	Alerts issued when the error is bu	Yes/ No	No	
	P782-P787	Set the output i0 after the reset	Out1 ~ OUT6 /No	No	Set after reset 10
	P788 P793		High levels of low waterFlat	Low level	
Pause settings	P40	Cause the automatic shift when suspended	Yes/ No	Yes	
	P41	Stop the needle position	On the position / downBit	On the positioning	
	P45	Pause switch type	Self-lock / ordinary	Self-lock	"Self-lock" is not automatically populated after the switch is pressed. "Ordinary" can be pre-pressed after the preamble.
	P799	Pause the pressure feet does not increase	Yes/ No	No	
Statistics set	P49	Clean the bottom when the power is	Yes/ No	No	When the power is turned off, the wire is margin is in0
	P50	The lower wire is stopped after the operation	Yes/ No	Yes	"Yes"Refers to the wire up to use the length of the wholeStop after the long
	P51	The wire meter counter is valid	Yes/ No	Yes	"Yes"Refers to the automatic statistics of the following wireUse the length
	P46	Clear counter when the power is	Yes/ No	Yes	When the power is turned off, let the sewing counterIn 0
	P47	The counter is successful	Yes/ No	Yes	When the sewing counter reaches the set value, is itContinued operation
	P48	The counter setting is valid	Yes/ No	Yes	Whether to sew the counter counter
	P52	Operation time counter	Yes/ No	Yes	"Yes"Refers to let the processing time statisticsEffective.

	P779	Underwater count mode	In1 ~ In4/ By default	By default	Underwater scale statistics
	P780	The bottom margin adjustment value (mm)	0 ~ 600000	0	The bottom of the balance of the margin
Set the grasping	P54	Sewing start grasping position	0 to 200	0	The grasping position of the sewing start
	P236	Laser output i0	Yes/ No	No	Output laser
	P693	Let the automatic change hook is valid	Yes/ No	No	

Parameter classification	Parameter name	Scope	Standard value	The meaning and comments of parameters	
Check out the wire	P55	The wire is detected	Yes/ No	Yes	"Yes"Refers to the afterbound, after the stopOperation and prompted Broken test function
	P56	The automatic cutting of the wire	Have/No	Have	"Yes"Refers to the afterbit wire, after automaticCrossing. From the detection wire to start the cutting.
	P57	No visual sewing clock number	1 to 255	3	The initial set of pin numbers does not mean wire
	P58	When the wire is detected with the effective number of the reference	1 to 255	2	If a wire set is set to set the number of pin,To consider independent of the wire
	P237	Fire output i0	Yes/ No	No	
Set the cutting wire	P60	Crossing the main axis rotation speed (r /min)	10 ~ 500	260	Cross the spindle speed of the
	P61	Delayed Circle Start (S)	0.01 to 6.55	0.01	The delay time of the cutting start
	P62	Diamond (S)	0.01 to 6.55	0.15	Dial machine action time
	P63	Matching the foot of the screwdriver to the latency (s)	0.01 to 6.55	0.25	DialOFFDelay time
	P65	Whether the seal is automatically sent when the seal isSilk	Yes/ No	Yes	Whether the wire is shifted when the space
	P66	Whether to use a dial	Yes/ No	Yes	Whether to use the dial
	P169	Line relaxation start mode	CornerSection/YaoLate	Perspective	Close the way of the loose line of the way
	P168	Line relaxation angle	0 ~ 999	850	Close the angle of loose
Power setting	P70	Close the angle of loose	Yes/ No	Yes	When the power is turned on, the needle bar is above
	P71	When the power is applied to the origin	Yes/ No	No	When the power is turned on, the cartridge is automatically automatically, the origin resetAutomatic
	P73	Pass-off-foot pressure	Yes/ No	Yes	When the power is turned on, the foot pressure rises
Other settings	P74	Whether to check the pressure	Yes/ No	No	"Yes" to operate,Once the probe is optimizedLow will stop and alarm
	P75	Whether the repeat is operated	Yes/ No	No	"Yes"After starting the start, the beginning of the same fileCirculation processing
	P76	Repeat the time of time (min)	1 to 65535	1440	Circulation processing time total time and time Once the end,Will stop cycle processing.
	P77	Repeated processing interval (s)	0 to 20	2	After the loop processing, the end of the processing to the weightThe interval between the new start
	P78	Operation end position	BackTo0/Right/Start sewing position/MoleculeKeep	Back to 0	Back to 0: XY axis coordinates all 0 points,Sewing end, reset point Right side: the right side of the

					processing range
					Start sewing position: the original seam of processing files Number of sink
					Default: The processing stopped once again
	P395	Repeated processing interval (s)	Barcode / electronicTags	Electronic standard Signs	Press the document to be continuously encoded: Barcode identification mold Formula
					Press the file name: the identification mode of the electronic tag

Parameter classification		Parameter name	Scope	Standard value	The meaning and comments of parameters
Other settings	P81	Interface mode	ByCategory/SingleOne	Classic	Classic: assume the body's button Refreshing: flat button holder
	P685	Start the movement mode before operation	XY at the same time / x excellentFirst/YSuchFirst	XY at the same time	
	P755	Operation of the hollow mode	XSuchFirst/YSuchFirst/XY With the sameTime	X Preferred	The air movement mode
	P241	Connect to the extended screen	Yes/ No	No	"Yes"Can be used to display the operatorThe information such as the display is displayed in the external zoom displayOn the on
	P79	The main shaft is stopped back	0 ~ 160	0	
	P242	Sound tips	High/In the/Low/ OFF	OFF	Show "high" "" low "sound soundVolume size
	P21	Let the power outage memory are valid	Is the/No	Is the	After the power-up, the sewing before the power is carried outSustained sewing
	P194	The electronic tag is separated when the file is valid	Yes /No	No	

4-25. 错误编码一览

Failure code	Fault content	Cause caused by fault	Solution
E001	There is no reset	After the power is not reset or reset abnormal power	Click the "Reset" button to reset
E002	Did not find z zero signal	<ol style="list-style-type: none"> 1.x axis limit sensor bad or wiring bad 2. Sensor or blank screws, or machineryThe card causes the shipment from less than the sensor 3. Parameter error, such as X-axis reset direction, poleSexuality, plate size, etc. 	<ol style="list-style-type: none"> 1. Check the sensor wiring, manually trigger the sensor, and watch "inputTest the "x limit text change. No change replacement 2. Check the structure 3. Reset or revolve the parameters
E003	Did not find the z zero signal		Reference e002Error processing method
E004	Did not find z zero signal		Reference e002Error processing method
E005	Did not find U zero signal		ReferenceE002Error processing method
E006	Extended shaft infinite bit signal		ReferenceE002Error processing method
E007	Spindle No internal zero signal	<ol style="list-style-type: none"> 1. Spindle encoder wiring bad 2. Spindle encoder is damaged 3. Power supply board damage 4. Motor damage 	<ol style="list-style-type: none"> 1. Check the spindle encoder wiring 2. Replace the spindle motor 3. Replace the power board 4. Replace the motor
E020	X-axis drive overpressure	<ol style="list-style-type: none"> 1. Load over and the shorter speed is too fast to stopOver pressure 2. Motherboard or power board is damaged, X-axis detectionPress more than 92V 	<ol style="list-style-type: none"> 1. Reduce the mask speed 2. Screen - Menu - Auxiliary Settings - Drive Preview - Internal Drive Preview - look at the current voltage of XZ axis, if not between 80-92V, Indicates that the power board fails to replace the power supply board if there is a one in thisThe mestellar meter is called the motherboard.
E021	X-axis drive undervoltage	<ol style="list-style-type: none"> 1. The battery voltage is too low 2. Power board fault 	<ol style="list-style-type: none"> 1. Check whether the X-axis drive voltage is less than 180V, see the surrounding device Whether there are high power devices frequently start, stop the opposite regulator. 2. Replace the power board
E022	X-axis drive hardware overcurrent	<ol style="list-style-type: none"> 1.x axis motor or bad line break damage short circuit2. Main board is damaged 	<ol style="list-style-type: none"> 1. Replace the motor 2. Replace the motherboard
E023	X-axis drive software overcurrent	<ol style="list-style-type: none"> 1. Parameters are not pairs 2. Motors are stuck 3. District or bad motor line breakage short circuit 4. Power supply board damage 	<ol style="list-style-type: none"> 1. Reset or revolve the parameters 2. Check the machinery 3. Check the replacement motor 4. Replace the power board
E024	X-axis driver encoderBarrier	<ol style="list-style-type: none"> 1. When the empty is returned to the shorter speed of the shorter2. Encoder wire contact bad or damage 3. Mechanical cards resulted in motor turnover 4. Main board is damaged 5. Motor damage 	<ol style="list-style-type: none"> 1. Reduce the mask speed 2. Check the wiring or replace the motor 3. Check the machinery 4. Replace the motherboard 5. Replace the motor

4-25. 错误编码一览

E025	X-axis drive open	1. Motor plug is not plugged or exposed to bad 2. Motor line is disconnected or damaged 3. Main board damage	1. Check the wiring 2. Replace the motor 3. Replace the motherboard
E026	X-axis drive overload	X-axis load over	Reduce the load
E027	X-axis drive position width		* Reservation message *
E028	X-axis drive AD samplingFault	1. Power out of the abnormal 2. Main board is damaged	1. Re-boot 2. Replace the motherboard
E029	X-axis drive overheating	Drive overload	Drive weight loss

Failure code	Fault content	Cause caused by fault	Solution
E030	Y-axis drive overpressure		ReferenceE020Error processing method
E031	Y-axis drive undervoltage		ReferenceE021Error processing method
E032	Y-axis drive hardware overcurrent		ReferenceE022 faultMutual treatment method
E033	Y-axis drive software overcurrent		ReferenceE023Error processing method
E034	Y-axis drive encoderBarrier		Reference e024Error processing method
E035	Y-axis drive open		ReferenceE025Error processing method
E036	Y-axis drive overload		ReferenceE026Error processing method
E037	Y-axis drive position width		* Reservation message *
E038	Y-axis drive AD samplingFault		ReferenceE028Error processing method
E039	Y-axis drive overheating		ReferenceE029 faultMutual treatment method
E040	Z-axis drive overpressure		Reference e020 errorMutual treatment method
E041	Z-axis drive undervoltage		ReferenceE021Error processing method
E042	Z-axis drive hardware overcurrent		ReferenceE022Error processing method
E043	Z-axis drive software overcurrent		ReferenceE023 faultMutual treatment method
E044	Z-axis drive encoderBarrier		Refer to E024 error processing method
E045	Z-axis drive open		Reference E025Error processing method
E046	Z-axis drive overload		ReferenceE026Error processing method
E047	Z-axis drive position width		* Reservation message *
E048	Z-axis drive AD samplingFault		ReferenceE028 faultMutual treatment method
E049	Z-axis drive overheating		ReferenceE029Error processing method
E050	Scissors Line Axuror Value Overpressure		ReferenceE020 errorMutual treatment method
E051	Scissors Long Axurius Undervoltage	1. The battery voltage is too low 2. Power board fault	1, to see whether the crush line axis voltage is less than 180V, see the equipment Whether there is a high power device frequent start-up; as the ground supply The 2. Replace the power board
E052	Scissors Long Drive HardwareFlow		ReferenceE022Error processing method
E053	Scissors Long Drive SoftwareFlow		Reference e023 wrongMutual treatment method
E054	Scissors Line Axural EncoderFault		ReferenceE024 faultMutual treatment method

E055	Scissors line axis drive open	<ol style="list-style-type: none"> 1. Motor seat contact bad 2. Motor line is disconnected or damaged 3. Watch the line module bad 	<ol style="list-style-type: none"> 1. Check the wiring 2. Replace the motor 3. Replace the scissors module
E056	Scissors Line Axurle Veteror		Reference E026 Error processing method

Failure code	Fault content	Cause caused by fault	Solution
E057	Scissors Line Axular LocatorDifference		ReferenceE027Error processing method
E058	Scissors Long Axular ActSample failure		ReferenceE028Error processing method
E059	Scissors Long-axis drive overheating		ReferenceE029 faultMutual treatment method
E060	Spindle overpressure	1. The voltage of the city is too high 2. Power board fault	1. Check the internal drive preview spindle voltage is higher than 400V, check Whether the power supply voltage is abnormal fluctuations, see if the equipment aroundThere is a high power device frequency dropping stop; equipped with regulator. 2. Replace the power board
E061	Spindle undervoltage	1. The battery voltage is too low 2. Power board fault	1. Check the internal drive preview the spindle voltage is less than 180V, look Whether the equipment is equivalent to the power of the power supply: as the case Rapid regulator. 2. Replace the power board
E062	Spindle hardware overcurrent	1.x axis motor or bad line break damage short circuit2. Main board is damaged	1. Replace the motor 2. Replace the motherboard
E063	Spindle software overcurrent	1. Parameters are not pairs 2. Motors are stuck 3. District or bad motor line breakage short circuit 4. Power supply board damage	1. Reset or revolize the parameters 2. Check the machinery 3. Check the replacement motor 4. Replace the power board
E064	Spindle encoder fault	1. Encoder wiring bad 2. Encoder is damaged	1. Check the motor encoder wiring 2. Replace the spindle motor
E065	Spindle block	1. Load overload 2. Spindle electrical mechanism of the staggered	1, reduce the load 2. Check the machinery
E066	The spindle controller detects the blockTransfer	Spindle load is too large	Check whether the spindle mechanical structure has problems
E067	Y Servo Hardware Protection (* Note: Y servo represents oldSingle board servo, X2 servo tableNew X servo, Y2 serv Official means new Y servo)	1. District or bad motor damage short circuit 2. Motors are stuck 3.Y Servo board damage 4. Power supply board damage	1. Check the replacement motor 2. Check the machinery 3. Replace the Y servo board 4. Reset or revolize the parameters
E068	Y servo Hoc		* Reservation message *
E069	Y servo AD module initialCorrect fault		ReferenceE028Error processing method
E070	Y Servo parameter storage abnormality	Storage chip exception	Replace the chip
E071	Y Servo System Parameter Abnormality	Parameter configuration error	Check the parameter configuration

E072	Y servo AD sampling module Fault		ReferenceE028 fault Mutual treatment method
E073	Y Servo Encoder Disc Lack	1.Y Servo encoder contact bad or broken 2.Y Servo motor damage 3.Y Servo board damage	1. Check the servo encoder line 2. Replace the servo motor 3. Replace the Y servo board
E074	Y Servo Encoder AB Disturbance	1.Y Servo Board for the old version 2. Servo encoder contact bad or wire break	1. Look "on the internal drive" - "Y Servo" - "version number" for the1 means that the old version needs to return to the update program 2. Check the encoder line
E075	Y Servo Encoder Z Interference		ReferenceE074 Mutual treatment method

Failure code	Fault content	Cause caused by fault	Solution
E076	Y servo bush undervoltage		ReferenceE410 faultMutual treatment method
E077	Y servo bus overvoltage		* Reservation message *
E078	Y Servo software overcurrent		ReferenceE023 errorRating method
E079	Y servo motor overload		ReferenceE026 faultMutual treatment method
E080	Y servo drive overload		Reference E026Error processing method
E081	Y servo motor overheating	Motor overload	Motor weight loss
E082	Y servo drive overheating		ReferenceE029Error processing method
E083	Y servo fan exception		* Reservation message *
E084	Y servo speed	1. Cable and encoder cable wiring with fault 2. The pulse frequency of the controller output is too large 3. Electronic gear is too large to set up too much 4. Servo gain settings are too large	1. Servo motor power cable and encoder cable wiring is correct,There is no break 2. The pulse frequency of the controller output is too large 3. Reduce the electronic gear ratio 4. Try to re-use manually or automatic adjustment of servo gain
E085	Y servo position deviations are too large	1.Y Servo Board for the old version 2. Machinery stuck	1. Look at the "Internal Drive" - "Y Servo" - no version number indicatesOlder version needs to return to the update 2. Check the machinery
E086	Y Servo bus voltage lack	1. Motivation wiring 2. Motor damage 3.Y Servo board damage	1. Check the motor wiring 2. Replace the motor 3. Replace the Y servo board
E087	Y Servo Motor Pot Order Error	Wiring phase order error	Press the correct phase order
E088	Y Servo Drive ToolStream error input		* Reservation message *
E089	Y Servo Brake Resistor overload		* Reservation message *
E090	Y Servo Absolute Value EncoderOverhead		* Reservation message *
E091	Y servo battery voltage low	The battery is always fully	Replace the battery
E092	Y servo multi-loop location informationHas been lost		* Reservation message *
E093	Y servo drive and motorMismatch	Motor model does not match	Replace the servo motor
E094	Y servo origin return failed	1. Motivation wiring 2. Motor damage 3.Y Servo board damage	1, check the motor wiring 2. Replace the motor 3. Replace the Y servo board
E095	Y Servo main power supply power		* Reservation message *

E096	Y servo offset angle failed		* Reservation message *
E097	Y Servo power back	<ol style="list-style-type: none"> 1. Load is too large 2. Overheat protection 3. The screw or nut is damaged 	<ol style="list-style-type: none"> 1. Lifting and negative 2. Calibration treatment 3. Includes accessories
E098	Y Servo initialization LAN9252 error		* Reservation message *
E099	Y Servo DSP and ESCLetter of interrupts		* Reservation message *

Failure code	Fault content	Cause caused by fault	Solution
E100	Y servo through the network cable and the mainMachine communication interrupt		* Reservation message *
E101	Y Servo PDO communication parametersRead only		* Reservation message *
E102	Y servo PDO communication does not haveThe index to find		* Reservation message *
E103	Y servo PDO communication synchronizationT ime ultra-range		* Reservation message *
E104	Y Servo PDO communication dataSuper range		* Reservation message *
E105	Y servo UWW on the short-circuit	1. Potential error 2. Power supply voltage is too high	1. Adjust the phase order 2. Reduce the supply voltage
E106	Y servo inertia identification failed		* Reservation message *
E107	Y Servo Encoder EEPROMRead and write failed		* Reservation message *
E108	Y Servo position forward limit		* Reservation message *
E109	Y Servo Location Negative Limit		* Reservation message *
E110	Y servo electronic gear is ratioMisunderstanding		* Reservation message *
E111	Y Servo input pulse frequencyToo high		* Reservation message *
E112	Spindle hardware protection	1. District or bad motor damage short circuit 2. Motors are stuck 3. Power supply plastic spindle module damage	1. Check the replacement motor 2. Check the machinery 3. Replace the power board
E113	Spindle encoder break	1. Spindle encoder contact bad or broken2. Spindle motor damage	1. Check the spindle encoder line 2. Replace the spindle motor
E114	Spindle encoder AB interference	1. Power board program for older version 2. Spindle encoder contact bad or wire break	1. Look "on-in-drive" - "spindle" - "version number" for 1Indicates that the old version needs to return to the file update program 2. Check the encoder line
E115	Spindle encoder Z interference		ReferenceE114Error processing method
E116	Spindle multi-row data extensions		ReferenceE092Error processing method
E117	Spindle absolute value encoderHot		ReferenceE090Error processing method

E118	The spindle battery voltage is low		ReferenceE091Error processing method
E119	The spindle multi-position is lost		* Reservation message *
E120	Spindle motor overload		ReferenceE026Error processing method
E121	Spindle drive overload		Reference E026 wrongMutual treatment method
E122	Spindle brake resistor overload		ReferenceE089Error processing method
E123	Spindle motor overheating		ReferenceE415 errorMutual treatment method
E124	Spindle drive is overheated		Reference e416 wrongMutual treatment method
E125	Spindle bus undervoltage		ReferenceE410Error processing method

Failure code	Fault content	Cause caused by fault	Solution
E126	Spindle bus overvoltage		* Reservation message *
E127	Spindle main power supply power		* Reservation message *
E128	Spindle software overcurrent		Reference E412 Error processing method
E129	Spindle position forward limit		* Reservation message *
E130	Spindle position negative limit		* Reservation message *
E131	Spindle electronic gear ratio error		* Reservation message *
E132	Spindle input pulse frequency overHigh		* Reservation message *
E133	Spindle position deviation is too large	<ol style="list-style-type: none"> 1. The main shaft board is older 2. Machinery stuck 	<ol style="list-style-type: none"> 1. Look "On - in - drive" - "Spindle" - no version number indicates oldEdition to return to the update program 2. Check the machinery
E134	Spindle excessive	<ol style="list-style-type: none"> 1. Wiring error 2. Acceleration is too large 3. Power grid voltage is too low 4. The main shaft power is low 5. Spindle to the short circuit 	<ol style="list-style-type: none"> 1. Check the line 2. Reduce the acceleration 3. Check the input power supply 4. Use the spindle of the power level 5. Check the spindle to the short circuit
E135	The spindle origin return failed		* Reservation message *
E136	Spindle bus voltage lack		* Reservation message *
E137	Spindle motor phase sequence error	Puthen the contrast	Measure the use of multimeter and restore the correct phase order
E138	The spindle UWW is short-circuited		Reference E105 error processing method
E140	1 spindle hardware protection (* Note: 1 Spindle representsSpindle, 2 spindle representationS p i n d l e)		
E141	1 spindleHoc		
E142	1 Spindle AD module initialCorrect fault		
E143	1 Spindle parameter storage abnormality		
E144	1 Spindle system parameter abnormality		
E145	1 Spindle AD sampling moduleFault		
E146	1 Spindle encoder break		
E147	1 Spindle encoder AB dryDisturbance		

E148	1 Spindle encoder Z interference		
E149	1 spindle bus undervoltage		
E150	1 Spindle bus overvoltage		
E151	1 Spindle software overcurrent		
E152	1 Spindle motor overload		
E153	1 Spindle drive overload		

Failure code	Fault content	Cause caused by fault	Solution
E154	1 Spindle motor overheating		
E155	1 Spindle drive overheating		
E156	1 Spindle fan exception		
E157	1 Spindle excessive		
E158	1 Spindle position deviations are too large		
E159	1 Spindle bus voltage lack		
E160	1 Spindle motor phase order error		
E161	1 Spindle drive of electricityStream error input		
E162	1 Spindle brake resistor overload		
E163	1 Spindle absolute value encoderOverhead		
E164	1 Spindle battery voltage low		
E165	1 Spindle multi-position position informationHas been lost		
E166	1 Spindle drive and motorMismatch		
E167	1 Spindle origin return failure		
E168	1 Spindle main power supply power		
E169	1 Spindle offset angle failed		
E170	1 Spindle power back		
E171	1 Spindle initialization LAN9252 error		
E172	1 spindleDSPAnd withESCPingLetter of interrupts		
E173	1 Spindle through the network cable and the mainMachine communication interrupt		
E174	1 spindlePDOComm unication parametersRead only		

E175	1 spindlePDOCommunication is notThe index to find		
E176	1 spindlePDOCommunication synchronizationTime ultra-range		
E177	1 spindlePDOCommunication dataSuper range		
E178	1 Spindle UVW on the short-circuit		
E179	1 spindle inertia identification failed		
E180	1 Spindle Encoder EEPROMRead and write failed		
E181	1 Spindle position forward limit		

Failure code	Fault content	Cause caused by fault	Solution
E182	1 Spindle position negative limit		
E183	1 spindle electronic gear is ratioMisunderstanding		
E184	1 Spindle input pulse frequencyToo high		
E200	XY drive alarm	1. Drive wiring bad 2. Drive damage	1. Check the wiring 2. Replace the motherboard
E201	X drive alarm		ReferenceE200Error processing method
E202	Y drive alarm		ReferenceE200Error processing method
E203	Please reposition the spindle	1. Winding is normally working but used to work for the power board Software hardware is too old 2. The spindle is stuck 3. Parameters are not pair 4. Spindle encoder wires or bad adverse 5. Spindle motor is bad 6. Power board or motherboard hardware 7. Motherboard with power supply Line of the line of the line of the wireLiang	1. Look "On-Dilers Preview" - "Spindle" - "version number", If you are less than 2, you need to update the program 2. Manually rotate and check the machinery 3. Reset or revolize the parameters 4. Check the wiring; manually turn a circle of QQP to change a period of time, Look at the "spindle 0 level level" whether to change once, no changeEncoder usage or bad or bad board is bad. 5. Replace the spindle motor 6. Replace the power board or motherboard 7. Check the cable
E204	Main motor direction error	1. Main motor direction parameter setting error 2. Multi-report for the power board fault	1. Change the main motor direction parameter in the software or screen 2. Replace the power board
E205	The blockboard does not put down	The current preamble is lifted	Click the "Boot" button to put down the box
E206	Machine head fault	1. The headboard connector is bad 2. Damage of headquarters 3. Main board damage	1. Check the headboard connector 2. Replace the headboard 3. Replace the motherboard
E207	Enter IO Timeout Troubleshooting	1. Corresponding input i0 wiring or sensor bad2. The corresponding input i0 mechanism can not be triggered 3. Parameter or file settings 4. Correct with the 00 of the sensor or PCB	1. Detect wiring or sensor 2. Check the mechanical structure 3. Check or reverse the parameters with the processing file 4. Confirm that the corresponding IO can be triggered in the screen "input test"Can not be replaced
E208	Less of pressure	1. Less of pressure 2. Pressure detection device failure	1. Check for the normal air supply 2. Check the air pressure detection device
E209	Motor scissors do not reach the place	1. Parameter is not pairs, such as scissors polarity 2. Sitting linear sensor wiring bad or bad3. Sensor or motor coupling loosely offset 4. The scissors motor is stuck 5. Motor damage 6. Motor corresponds to the drive board damage	1. Reset the parameters 2. Check the wiring or replace the sensor 3. Check the machinery 4. Check the scissors motor 5. Replace the motor 6. Replace the corresponding drive board

E210	Motor presters are not in place	<ol style="list-style-type: none"> 1. zero-parameter setting error 2. If the zero bit is outside, the zero sensorWiring bad or damaged, or install loose 3. If the motor encoder zero, it is encodedThe bad line is bad or damaged 4. Press the motor test or cedar loose 5. Motor damage 6. Motor corresponds to the drive board damage 	<ol style="list-style-type: none"> 1. Change zero parameters P687 2. Check the wiring or replace the sensor 3. Check the encoder line or replace the motor 4. Check the mechanical structure 5. Replace the motor 6. Replace the corresponding drive board
------	---------------------------------	--	--

Failure code	Fault content	Cause caused by fault	Solution
E211	Circle the motor does not place		Check whether the zero signal is the normal signal
E212	Cutter is not in place	<ol style="list-style-type: none"> 1. Sensor wiring or damage 2. Sensor installation position deviation 3. Cutter motor can be held or loose 4. Parameter setting error 5. Control the cutter drive to make 10 exception or Valve fault 6. Motor damage 7. Controlling the bad or drive damage 	<ol style="list-style-type: none"> 1. Check the wiring or replace the sensor 2. Adjust the sensor mounting position 3. Check the cutter motor 4. Reset or revolve the parameters 5. Test cut into correspondence I0 features such as lift rotation 00 6. Replace the motor 7. Check the line, replace the drive
E213	Bread	<ol style="list-style-type: none"> 1. Sewing needle line is broken 2. Disturbing detection device failure 3. Parameter error 	<ol style="list-style-type: none"> 1. Reinterpipe the needle line 2. Check the disconnect device, confirm the passage in the "input test" interface Sensor 3. Reset the parameters
E214	The number of work members is full	<ol style="list-style-type: none"> 1. Processing statistics "Current value" of the "Top Top after the Total Captured 	<ol style="list-style-type: none"> 1. Realize the current value or the total number of campaigns 2. If you count the count statistics, you can close the counter in "statistics set" Features
E215	The bottom line has been finished	<ol style="list-style-type: none"> 1. Processing Statistics Interface "Bottom Line Length Length Bigly equal to "the bottom line length" 	<ol style="list-style-type: none"> 1. Requires the bottom line shuttle and reset the corresponding bottom line length 2. If you do not need to use the bottom line statistics, you can in the "statistics set" Close this function
E216	The file is too large	Graphic file pin is out of the maximum range	Need to change the small graphic file
E217	No working file	<ol style="list-style-type: none"> 1. Lock file, the electronic tag is not scanned to the There are graphic names, press to start 2. Screen with the motherboard file failure 	<ol style="list-style-type: none"> 1. Repet the scan or switch the graphic file 2. Check the line, upgrade the motherboard and the program
E218	Waiting for work data	<ol style="list-style-type: none"> 1. File is too large, processing motherboard waiting for the screen Output file 2. The wire contact is bad or broken 3. The line is bound together with a strong interference 4. The screen or motherboard is too old 5. Screen or motherboard hardware damage 	<ol style="list-style-type: none"> 1. When you wait for a while to automatically disappear 2. Check the line 3. Draw a line of wires and motor power lines such as the line 4. Upgrade the latest screen or motherboard program 5. Test can upgrade the motherboard program; in the "test transmission" interface Try to communicate normally, not normal replacement of hardware
E219	Electrical fault, please contact factory Home	Motherboard hardware abnormal	Contact device manufacturers
E220	Error upgrade file	<ol style="list-style-type: none"> 1. Upgrade file does not fit this system 2. Upgrade the file damage 	<ol style="list-style-type: none"> 1. Use the corresponding upgrade file, such as the BPO1 system can only blete BPO1 Program 2. Make sure the U-David file is damaged
E221	Upgrade file type error	Upgrade File Damage or Upgrade File Not Fastest System.	Need to select the corresponding type of upgrade file to upgrade
E222	Not verifying the upgrade system, Can not upgrade	Motherboard hardware abnormal	Contact device manufacturers

E223	Not the same OEM manufacturer Upgrade file	Upgrade file version does not match	The non-systematically acquires the genuine upgrade file
E224	The headboard can not be connected	1, headboard and motherboard connection wire break or access Mouth loose 2. Holder or motherboard hardware fault	1. Check the cable of the headboard 2. Replace the headboard or motherboard
E225	Is connecting the main control board	1. The screen interface loosen or damaged 2. Screen or motherboard hardware fault	1. Check whether the wire is negative or damaged 2. Replace the screen or motherboard

Failure code	Fault content	Cause caused by fault	Solution
E226	The current file is invalid	1. No elevation of the upgrade file is upgraded 2. Draw the file damage or type error 3. The disk is not compatible or damaged	1. Insert the U disk and select the upgrade file 2. Replace the correct file 3. The Replace the U disk
E227	File transmission failure	1. The screen interface loosen or broken 2. The screen or motherboard is too old 3. Screen or motherboard hardware fault 4. The line is bound together with a strong interference	1. Check the line 2. Upgrade the latest screen or motherboard program 3. Test can upgrade the motherboard program; in the "test transmission" interface Try to communicate normally, not normal replacement of hardware 4. Draw a line of wires and motor power lines such as the line
E228	Data is out of range	The current graphic file data exceeds the maximum web Limited range	Check the graphic data is abnormal
E229	This modification is too large	A single modified graph angle value is too large	Reduce the angle value of the modified
E230	Graphic data is loading	Process the necessary graphic data	Need to wait for a while, then
E231	Follow the pressed alarm	1. Press the foot press when the rotation is turned 2. Parameter setting error	1. Check whether the pressure footing motor is normal 2. Reset the parameters
E232	No U disk was detected	1. The disk is not inserted or damaged 2. Dip U-disc interface damage	1. Reinsert inserted U disk or replace the U disk 2. Insert the other U disk interface or switch
E233	File read and write errors	URD reads an error when reading	1. Replace the graphic file 2. Reinsert the U disk or replace the U disk
E234	Graphics or head offset	1. Document size is too large than the scope of the scope 2. Document small but offset out of the scope of processing 3. Headband offset 4. Parameter fault, such as platen size	1. Replace the small size of the smaller graphics 2. Reset the reference point position 3. Receive the header 2 or head 3 head offset value 4. Set the voltage division corresponding to the machine
E235	The file is not a processing file	File content or format error	Replace the identifiable graphics files
E236	Ferroelectric damage	The motherboard is bad	Replace the motherboard
E237	Please keep the management password	Set up the management password	A first-to-pass management is required
E238	This type does not support editing	Do not need to edit the instructions or files	Do not need to edit the instructions or files
E239	Please contact the manufacturers	Contact manufacturers	Contact manufacturers
E240	Communication fault 2	1. The wire contact bad or damage causes CAN pass Mail fault 2. The screen or motherboard is too old 3. Screen or the main panel	1. Check the line 2. Upgrade the latest screen or motherboard program 3. Replace the screen or motherboard
E241	Time exception	Current date time error	1. Time is illegal to modify 2. Main board battery is less inefficient

E242	No work IO	1. Work enable input signal IO signal exception 2. Parameter setting error	1. Check the corresponding IO 2. Close the "Working Enable input IO" function to set the parameter value to 0
E243	Waiting for input i0	1. Input file i0 signal in the file 2. Corresponding to the input i0 sensor contact bad or Damage or can not be triggered 3. Parameter or file settings	1. After detecting the corresponding IO automatically disappear 2. Check the sensor failure 3. Reset the parameters or processed files
E244	Is execution delay	1. Execute the delay instructions in the graphics file 2. Set the delay time too long	1. After the completion of the delayed automatic disappearance 2. As the reset delay
E245	The file name is too long	The file name of the write tag is written length more than 32Bytes (32 English or 16 characters)	Need to shorten the length of the file name and write

Failure code	Fault content	Cause caused by fault	Solution
E246	Please grail out his feet	Not lifting foot	Click the "Press" button to lift the footsteps
E247	The pressure box is not depressed	Uncrowded downbucks	Click the "Boot" button to put down the block
E248	The auxiliary pressure box is not depressed	1. Unbounded auxiliary pressure box 2. Parameter setting error	1. Click the corresponding IO button on the auxiliary flag box 2. Reset the parameters
E249	The pressure box and the auxiliary pressure box are not compressedUnder the next	1. Unbreeding the box and the auxiliary pressure box 2. Parameter setting error	1. Click the corresponding key to press the block and the auxiliary pressure box. 2. Reset the parameters
E250	Punching the material has been complete	Punching the material has been complete	Need to replace the new punching material
E251	Reset failed	Because of the various reasons caused by reset failure, as freeLot of the origin	Go to "Auxiliary Settings" - "Test Transfer" - "Alarm Log" ViewThe reset failed in the same time there are alarm, reference before the alarm faultTo solve these alarm reset.
E252	Rotating the motor fault	1, the rotating motor due to mechanical overload and other causing a rotationDrive alarm 2, the rotation of the motor line break, the connectionMotivation, motor and drive cable failure 3, rotating axis drive bad 4. Rotate the motor damage	1. Check the mechanical for the stuck 2. Check the corresponding wiring 3. Replace the drive of the shutter 4. Replace the motor
E400	Drive board can not connect	The motherboard circuit appears abnormal	To maintenance board circuit
E401	(0x) drive board hardwareProtecti on	1. District or bad motor damage short circuit 2. Motors are stuck 3. Drives damaged 4. Parameters are not pair	1. Check the replacement motor 2. Check the machinery 3. Replace the Y servo board 4. Reset or revolize the parameters
E402	(0x) drive board HOC		* Reservation message *
E403	(0x) drive board AD modeBlock initial correction fault		* Reservation message *
E404	(0x) drive board parametersStorage abnormalities	1. memory exception 2. memory is not enough	1. Maintenance memory 2. Extend the memory or clean up the data
E405	(0x) drive board systemParameter abnormalities	There is a problem with the drive	Update the drive
E406	(0x) drive board ADSample module fault		Reference e028Error processing method
E407	(0x) drive board codingDeterminati on of wire	1. Drive board encoder contact bad or broken2. Motor damage 3. Main board damage	1. Check the drive board encoder line 2. Replace the motor 3. Replace the motherboard
E408	(0x) drive board codingAB interference	1. Drive program for older 2. Servo encoder contact bad or wire break	1. Look "on the internal drive" - "Y Servo" - "version number" for the1 means that the old version needs to return to the update program 2. Check the encoder line

E409	(0x) drive board codingZZ interference		ReferenceE408Error processing method
E410	(0x) drive board busUndervoltage	<ol style="list-style-type: none"> 1. Voltage reduction 2. Bus load overweight 3. Transformer fault 	<ol style="list-style-type: none"> 1. Run the voltage 2. Reduced operation 3. Repair or replace the transformer
E411	(0x) drive board busOvervoltage		* Reservation message *

Failure code	Fault content	Cause caused by fault	Solution
E412	(OX) drive board softwareOvercurrent		ReferenceE023Error processing method
E413	(0x) drive board motorOverload		ReferenceE026Error processing method
E414	(OX) Drive board driverOverload overload	1. friction of the weight load load 2. Power is not insufficient or internal parameters to adjust the improper	1. Looping oil 2. Adjust the gain or adjustment parameters
E415	(0x) drive board motorOverhead		* Reservation message *
E416	(OX) Drive board driverThe superheat is overheat		Refer to E029 error processing method
E417	(OX) Drive board fanAbnormal		* Reservation message *
E418	(0x) drive board over-speed	1. Wiring error 2. Acceleration is too large 3. Power grid voltage is too low 4. Drive low power 5. Drives on the short-circuit	1. Check the line 2. Reduce the acceleration 3. Check the input power supply 4. Use the power level of the power level 5. Check the drive short circuit
E419	(0x) drive plate positionThe deviation is too large	1. Location deviation parameters are set up2. Servo unit circuit board fault 3. Servo motor U \ v \ w wiring is not normal(The defaults) 4. Adjustment of the servo unit Adjustment 5. The frequency of the position instruction pulse is too high 6. Load condition and motor specifications are not	1. Reset the correct parameters 2. Replace the servo unit 3. Correct the motor (encoder) wiring 4. Radial speed gain, position loop gain 5. Reduce the location command frequency; add smoothing function: re-commentEvaluation of electronic gear ratio 6. Reevaluate the load or motor volume
E420	(OX) Drive board busVoltage shortage		ReferenceE086 wrongMutual treatment method
E421	(0x) drive board motorPotential phase	Puthen the contrast	Measure the use of multimeter and restore the correct phase order
E422	(OX) Drive plate ratingCurrent input error		* Reservation message *
E423	(OX) Drive brake brakeResistor overload		ReferenceE089Error processing method
E424	(0x) drive board absolutelyThe value encoder is overheated		ReferenceE090 faultMutual treatment method
E425	(OX) drive board batteryVoltage is low		ReferenceE091 faultMutual treatment method

E426	(OX) Drive plate multi-circleLocation information is lost	Battery-absolute encoder voltage is too low	Replace the battery
E427	(OX) Drive board driverThe machine and the motor do not match	Do not match the motor with motor power	The servo drive uses a limit current; limit the torque to 50%
E428	(0x) drive board originReturn to failure		Reference e094 Error processing method
E429	(0x) drive board main powerSource power out	1. Voltage is too low 2. Power failure	1. Improve the voltage 2. Increase the power supply

Failure code	Fault content	Cause caused by fault	Solution
E430	(0x) drive board offsetCorner learning failed		* Reservation message *
E431	(0x) drive board power outRestart		Reference E097 Error processing method
E432	(0x) drive board initialLAN9252 error		* Reservation message *
E433	(0x) drive board DSP andESC communication interrupt		
E434	(OX) drive board throughCable and host communication interrupt		* Reservation message *
E435	(0x) drive board PDO passThe letter parameters read only		* Reservation message *
E436	(0x) drive board PDO passLetter does not find the index		* Reservation message *
E437	(0x) drive board PDO passSynchronous time ultra-range		* Reservation message *
E438	(0x) drive board PDO passThe data is ultra-range		* Reservation message *
E439	(0x) drive board UWW pairModing short		Reference E105 Error processing method
E440	(0x) drive plate inertialIdentify failed		* Reservation message *
E441	(0x) drive board codingEEPROM read and write failed		* Reservation message *
E442	(0x) drive plate positionPrimary limit		* Reservation message *
E443	(OX) drive board positionNegative limit		* Reservation message *
E444	(0x) drive board electronicGear is more than the error		Reference e110 Error processing method
E445	(0x) driver board inputPulse frequency is too high		Reference e132 Error processing method

E446	(0x) drive board motorOverheating warning		ReferenceE081 faultMutual treatment method
E447	(0x) drive board driverOverhead warning		ReferenceE081 faultMutual treatment method
E448	(0x) drive board motorOverload warning		ReferenceE026 faultMutual treatment method
E449	(0x) drive board driverOverload warning		Reference e026 wrongMutual treatment method
E450	(0x) drive plate positionDeviation too large warning		ReferenceE419Error processing method

Failure code	Fault content	Cause caused by fault	Solution
E451	(0x) drive board brakeOverload warning		ReferenceE026WrongMutual treatment method
E452	(OX) Drive board forwardHarbor warning	More than the system settings for the set of soft setting settings	Modify the set parameter or reset
E453	(OX) Drive board reverseHarbor warning	More than the set target trip	Press the reset key reset
E470	(0x) drive board overpressure	Regulator failure	Maintenance regulator
E471	(0x) drive board undervoltage	1. Vacuum voltage, the external input voltage is too low2. Harmonic interference	1. Replace the power supply or the regulator 2. Need to add the servo drive input in the servo drive inputEnd-dedicated filter to solve
E472	(0x) drive board hardwareOvercurrent	1. Power supply voltage is too large 2. Dissipheries that hardware are caused by resistance	1. Stepmapraption 2. Replace the hardware
E473	(0x) drive board softwareOvercurrent		ReferenceE023Error processing method
E474	(OX) Drive plate codeFault failure		ReferenceE024Error processing method
E475	(OX) drive board open		ReferenceE025Error processing method
E476	(OX) drive board overload		ReferenceE026Error processing method
E477	(OX) drive board positionSuper poor		Reference e027Error processing method
E478	(OX) Drive plateADTakeSample failure		ReferenceE028 faultMutual treatment method
E479	(0x) drive board overheating		Reference e029Error processing method

5. 缝纫机的维修保养

△ Warning

In order to prevent sudden start to cause personal accident Power and then proceed.
In addition, before running the sewing machine, please remove the remote shrouds to the original site.

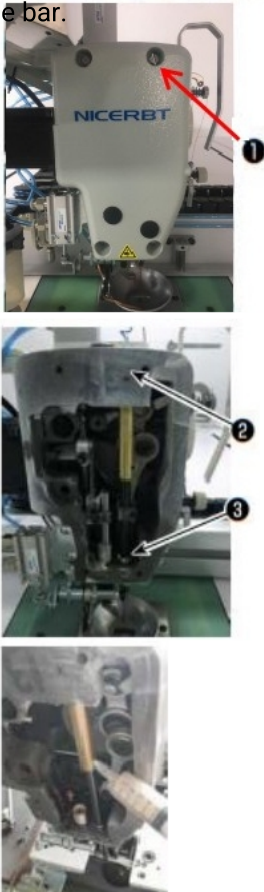
Numbering	Parts	Description	Operating hours
1	<p>Next area, container peripheral area, spinningShort box and internal, cutting parts, needle barDomain, inner and outer pressure foot area, electronic control box suctionExhaust port, solar fiber, wire, and otherThe residual material is easy to accumulate the part.</p> 	<p>Please use air jet guns and other tools to mechanicalThe surface is cleared. Especially the above-mentioned broken filamentsAnd the contents of the wire, and other residual substances easilyAccumulated part, please pay attention.</p>	8 hours
2	<p>The corn is injected into the needle bar.</p> 	<ol style="list-style-type: none"> 1. Loosen the panel screws ①, remove the panel. 2. Loosen the screws of the metal pieces above the needle ②, the needle below the metal pieces of the screw 8, And removed. 3. Let the grease-based on-demand oils on the needleThe metal welded hole and injection of the lubricationSelf-grease. (Refer to Figure 1, Figure 2) 4. Oil improver is not less than 0.5cm³. 5. After oil, Please tighten the screws of the metal pieces on the needle bar, Let the panel reset. Tighten the screws of the panel. 6. About greases should be lithium series 2No. should not be mixed with other greases. 	Running 720 hours

5. 缝纫机的维修保养

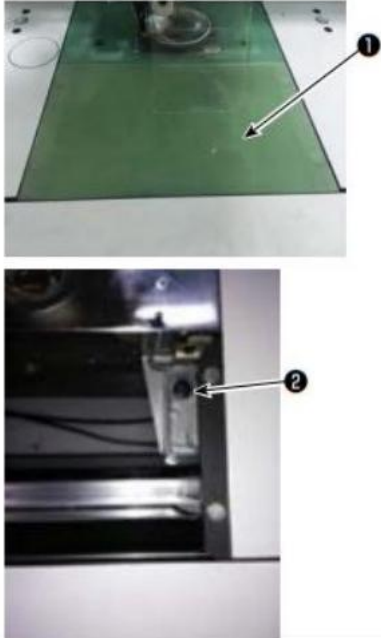

Figure 2

Numbering	Parts	Description	Operating hours
3	<p data-bbox="202 203 505 229">Oil to the container tank oil.</p> 	<ol style="list-style-type: none"> <li data-bbox="609 203 915 229">1. Remove the safety cover. <li data-bbox="609 236 988 292">2. Remove the rubber thread of the tank. <li data-bbox="609 298 958 422">3. Pot the aerial pan of the tank with the subsidence (or Specifies the lubricating oil. <li data-bbox="609 428 929 526">4. If the oil reaches the top scale of the tank, Stop the oil. <li data-bbox="609 532 953 588">5. Remove the rubber thread to keep the safety hood. 	<p data-bbox="998 203 1258 395">When the oil tank is less than the lower Please add affiliated as a square (Or specified) of the lubricating oil.</p>

Numbering	Parts	Description	Operating hours
4	<p data-bbox="201 209 594 265">Pet the lubricating oil to the gear box.</p> 	<ol style="list-style-type: none"> <li data-bbox="608 209 981 401">1. Remove the four screws ①, remove the container Full cover. Remove the six screws ⑧, remove the gear box Safety cover ④ and gasket. <li data-bbox="608 416 981 472">2. Slowly operate the gear box to the white gear box Silhouette. <li data-bbox="608 486 981 609">3. When the oil scale of the oil reaches the upper scale B When stopping, oil is stopped. <li data-bbox="608 623 981 706">4. Square gear box safety cover pads, security Cover, container safety hood reset, tighten the screws. 	<p data-bbox="995 209 1266 368">When the oil scale is lower than the lower square Section A When you please add No. 32 White lubricants.</p>

5-1.缝制时的故障、原因和对策

NowLike	The originalDue	YesCountermeasure
1. Start the time outline.	<ul style="list-style-type: none"> ① always jumping the needle. ② tangent length after the tangent length. ③ bottom line is too short. ④ the first line of the line tension high. ⑤ The first pin is the small pinch size. 	<ul style="list-style-type: none"> O adjust the needle and the gap of the container. O Sets the soft start when the seat is set. o Weaken the tension of the first line of tension. O Enhance the pick-up spring. O Weakened bottom line tension. O To meet the gap of the needle and the fixed knife. O Weake the first line of the upper tension, to extend the AT action when the lifting.O increases the sewing pin of the first needle. O Reduces the line tension of the first needle.
2. Regularly broken. Fluid filament pull.	<ul style="list-style-type: none"> ① shock, suspension hook has scars. ② pinhole guide has scars. ③ the line into the tachwrough of the hopper. ④ uplink tension too strong ⑤ pick-up spring too strong. ⑥ fiber-type hot and break. ⑦ up the pull line, the tip to the sewing machine line. 	<ul style="list-style-type: none"> O Remove the shock, smooth with fine grinding or rasp.O with a crestatting a pinhole guide or replacement. O Remove the hopper and clear the line. O Weak the tension. O Weaker the balloon. O Use the optional needle cooling device. O Confirm whether the needle is observed. O Use the ball pin.
3. Run dispensets.	<ul style="list-style-type: none"> ① needle bend. ② the needle to touch the foot. ③ the needle is too thick. ④ the gap between the machine and the hopper. 	<ul style="list-style-type: none"> O Replace the needle. O Adjust the position of the foot pressure. O Opid the appropriate needle according to the sewing. O adjust the needle and the spot of the gap.
4. Cancel continues to. (Only bottom line)	<ul style="list-style-type: none"> ① fixed knife is not fast. ② low pressure of the fixed knife. ③ fixed fixture is not good. ④ final needle jumper. ⑤ bottom line tension low. ⑥ fabric suture. 	<ul style="list-style-type: none"> O Replace the fixed knife. O Adjust the pressure of the fixed knife. O Adjust the fixed knife position. O adjust the needle and the hopping synchronization. O Improve the bottom line tension. O drops the height of the presser.
5. Regular jump.	<ul style="list-style-type: none"> ① The gap between the machine and the hopper is not good. ② the suspension hook relative to the position of the needle is not good.③ needle bend. ④ tangent line is too long. 	<ul style="list-style-type: none"> O adjust the needle and the spot of the gap. O adjust the position of the hobbit position hook relative to the needle. O Replace the needle. o Weaker the balloon. O Enhances the tension of the first line of tension.
6. Online from the cloth of the clothOut of.	<ul style="list-style-type: none"> ① tight line tight is not good. ② tangent line is too long. 	<ul style="list-style-type: none"> O Weak the tension. O Enhances the tension of the first line of tension.
7. Bread when the tangent is broken	<ul style="list-style-type: none"> ① knife position is not good. 	<ul style="list-style-type: none"> O adjust the knife position.
8. On the surface of the fabric, the first 1The pin is exposed.	<ul style="list-style-type: none"> ① first needle jump. ② use the needle and line compared to the internal diameter of the pipeline and the line is too thick.③ middle pressure and the needle different. ④ air drums are not good, disk feet can not be pressedStitch the needle on the line. 	<ul style="list-style-type: none"> O long length of the line after the tangent tangent. O Replace the large-scale pressure in the diameter. O adjust the needle and the median feet deviation, the machine is filled in the middle footCenter. O adjust the air blowing in the sewing direction, so that the disc foot can beTo press the online on the needle.
9. Online winding to the ZunjunBit hook.	<ul style="list-style-type: none"> ① the closure of the hut closure and the spin shuttle is too small. 	<ul style="list-style-type: none"> O Adjust the shot closure hook and the hopping clip in the use of the line of the lineThe gap.

5-1.缝制时的故障、原因和对策

10. Site starts the second needleBottom line tail exposed tableFace.	① hopper cylinder is too large. ② bottom line tension low. ③ the first line of the line tension is too strong.	o adjust the hole of the shuttle to prevent the height of the idling spring. O Enhance the bottom line tension. O Reduces the line tension of the first needle.
--	--	---

5-2. 电池的废弃



On the operating panel, due to power supply OFF When the clock is also allowed, there is a built-in battery. About the absence of battery, please be implemented correctly according to national laws.

■ The demolition of the battery



1) Locking the back of the sewing machine or side of the door ① After the unlock is open.

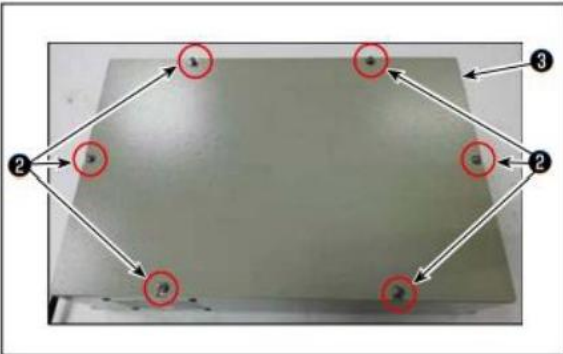

2) inside the battery pack ⑥ protective plate screw ② remove the battery, Protective plate removed.

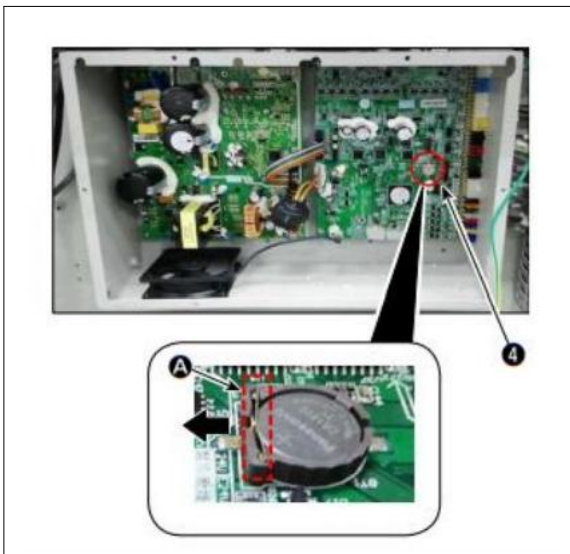

3) battery ④ The core splice slides along the direction of the arrow and the battery ④ Remove.