

SIRUBA

電控參數說明書

ELECTRONIC CONTROL PARAMETER MANUAL

■ C007LQT

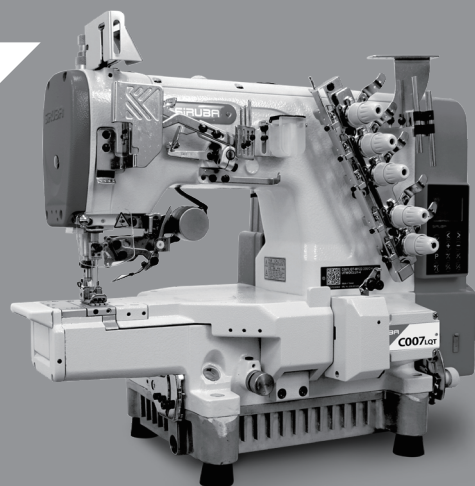

C007LQT 步進款使用說明書

User manual of Siruba C007L stepper Motor

前言

Foreword

歡迎使用本公司產品，製衣行的正確投資選擇！

Welcome to use our products, it is the right investment choices in garment industry!

本說明書為本公司新研發的“繡縫機自動剪線”產品做對照參考手冊，請認真閱讀此手冊以便更好的運用本公司產品！

The User manual is for our newly developed “W1500 Auto-Trimmer servo Motor system” products Reference Manual, Please read this manual carefully, hope it can give you useful help.



閱讀本說明前以下要求說明請注意

Before reading the manual, Please note the following requirements

- 1、用戶使用作業前必須可靠接地，保證人身安全！
The user must be grounded before operations to ensure safety
- 2、非專業人士請勿拆卸控制箱
non-professionals do not disassemble the control box
- 3、控制箱與電機遠離強磁高輻射環境
The control box and motor away from the magnetic high radiation environment
- 4、不要在過熱環境中作業
Do not work in hot environments
- 5、不要在過於潮濕環境中作業
Do not work in humid environments too
- 6、使用者保證供電電壓的穩定（210V~240V）
Users to ensure stable supply voltage (210V ~ 240V)

安全叮囑：Safety requirement

- 1、電機接通時請不要把腳放在腳踏板上
Do not put your feet on the pedals when the motor is switched on
- 2、本產品請專業人士安裝調試
Let professionals to install and debug this product
- 3、嚴禁在通電時打開控制箱與電機端蓋
Do not open the control box and the motor cover when energized
- 4、換針，穿線或更換底線時請關閉電源
Please turn off the power when changing the needle, threading or replacing the bottom line
- 5、安裝，拆卸維修時請關閉電源
During installation and removal service, please turn off the power
- 6、翻抬縫紉機時請關閉電源
Please turn off the power when turn lift sewing machine

保修策略：Warranty Policy

- 1、本產品自購買起免費保修 2 年，終身維護。保修期內除人為損壞外出現任何品質問題可免費修
Since from the purchase of this product, we give 2-year warranty for free, Lifetime Maintenance. during the warranty period ,Any quality problems the product will be free repaired, Except artificial damage.
- 2、未經本公司同意自行拆卸，改裝造成損壞將不給於保修。
without our consent disassemble or modify, the damaged will not give in warranty
- 3、但凡出現無法解決的問題可以聯繫本公司
Whenever find the problem can not be solved, you can contact the company

目錄

Contents

電控介紹

Servo System Introduction

一：顯示幕常用操作介紹

Introduction of display screen common Operation

二：如何進入參數與如何修改參數

How to enter parameters and how to modify the parameters

三：指令引數說明表

Operating Parameter Description Table

四：控制箱埠說明

The control box Port Description

五：錯誤代碼解析

Error code analysis

一：顯示幕常用操作介紹



Introduction of display screen common Operation









1、顯示幕介紹如下：The display screen is described as follows



2. 功能介紹：Function introduction



序號 Serial No.	按鍵圖示 Button Icons	功能說明 Function Description	
1		參數確定保存鍵 Parameter determines the Save button	
2		慢啟動功能鍵 ※：短按進入慢啟動開啟或關閉。 Slow start function key ※：Press to turn on or off the function of slow start	向左鍵（在進入參數項時游標向左移） Left key (when adjusting items)

3		機頭 LED 燈開關鍵 ※：亮度 0-5, 0 表示機頭 LED 關閉 1-5 檔時 機頭 LED 開啟 Machine head LED light On or Off key ※：luminance value 0-5, 0 means the LED light off. 1-5 means the LED light on	向右鍵（在進入參數項時游標向右移） Left key (when adjusting items)
4		“+” 鍵（修改參數時加），處於主介面時按一下加 50 速度 “+” button (modify the parameters plus), increase 50RPM when pressing the key for once time on the host interface	
5		“-” 鍵（修改參數時減），處於主介面時按一下減 50 速度 “-” button (modify the parameters minus) , decrease 50RPM when pressing the key for once time on the host interface	
6		按 P 鍵同時按+，進入用戶參數。 按 P 鍵同時按-，輸入密碼，進入系統參數。 Press P and +, enter the user parameters. Press P and -, enter the system parameters with password.	
7		剪線自動抬壓腳模式（剪線後自動抬起壓腳） ※：開啟或關閉 Auto- trimmer and auto-foot lifter function(after auto-trimmer, the foot lifter automatically) ※：turn on or off	
8		剪線模式： 按 OK 進入後重複按此鍵開啟或關閉剪線模式 壓腳模式： 按 OK 進入後 半後踏抬壓腳 開啟/關閉 中途抬壓腳 開啟/關閉 Trimming mode: Press OK key to enter, repeat the key to turn on/off the trimming function Presser foot mode: Press OK to enter, turn on/off the function of the half backward presser foot lifting, turn on/off the function of the halfway presser foot lifting	
9		多段縫/自由縫紉模式 Multi-part sewing mode/ Free sewing mode	
10		針位調節 上陣位/下針位 Needle position adjusting Up needle position/ Down needle position	速度調節 Speed adjusting
11		剪線後撥線： 開啟/關閉 Hoking the thread after trimming Turn on/ off	





二、如何進入參數與如何修改參數



How to enter parameters and how to modify the parameters

系統參數進入解析：

1. 按 () 鍵同時按 () ，進入用戶參數，用 () () 選擇參數，用 () ()

鍵調整參數值，按 () 鍵確認。

2. 按 () 鍵同時按 () ，輸入密碼 2014，進入使用者參數，用 () () 選擇參數數值，用

() () 鍵調整參數值，按 () 鍵確認。





注：以上是進入方法，具體參數號代表的參數意思詳情如下 “3.指令引數說明表”

System parameters entering analysis:

1. Press () and () key to enter the user parameter, select the parameter with () ()

key, adjust the value with () and () and key, confirm with () key.

2. Press () and () key to enter the user parameter, enter the parameter with password 2014, select

the parameter with () () key, adjust the value with () and () and key, confirm with

() key.

Note: the upper is entry method, specific parameters No. on behalf of the parameters meaning as follows: “三：Operating Parameter Description Table”

三：操作參數說明表： Operating Parameter Description Table

菜單號 System parameter list	功能說明 Function Description	電磁鐵 款	氣動款	步進款	步幅	範圍	參數說明
P1	最大縫紉速度 MAX Sewing speed	3000	3000	3000	100	200~6500	轉 / 分鐘 Round / Minute
P2	起縫速度 Start sewing speed	250	250	250	50	150~800	轉 / 分鐘 Round / Minute
P3	踏板加速曲線 Pedal acceleration curve	85	85	85	1	10-100	
P10	剪線速度 Trimming speed	350	350	350	10	150~600	
P11	慢啟動選擇 Slow Start Selection	0	0	0	1	0~1	0：禁用 1：啟用 0: Disable 1: Enabled
P12	慢啟動針數 Slow start Stitches number	2	2	2	1	0~30	針數 Stitch number
P13	慢啟動速度 Slow start speed	400	400	400	50	200~800	轉 / 分鐘 Round / Minute
P20	加速靈敏度 Acceleration sensitivity	4	4	4	1	1~6	
P21	恢復出廠設置 Restore factory settings	0	0	0	1	0~3	
P22	電機驅動方向 Motor drive orientation	1	1	1	1	0~1	0：逆時針 1：順時針 0: Counterclockwise 1: Clockwise
P23	顯示當前速度 Displays the current speed	0	0	0	1	0~9999	顯示當前的電機轉速 Displays the current motor speed
P24	顯示調速器電壓 Display foot controller voltage	0	0	0	1	0~9999	顯示調速器輸出電壓 Display foot controller output voltage
P25	自動磨合運行 Automatic running-in operation	0	0	0	1	0~1	0：關閉 1：啟動 0：OFF 1: ON
P26	後踏復位W縫 Backward to reset W sewing	0	0	0	1	0~1	
P27	自動 W 縫觸發方式 Auto W sewing touch off mode	0	0	0	1	0~3	
P28	自動找針位 Finding the needle position automatic	1	1	1	1	0~2	
P34	上停針角度 The angle of upper needle stop position	0	0	0	1	-30~30	
P35	下停針角度 The angle of down needle stop position	150	150	150	1	150-300	
P36	剪刀動作延時啟動時間	20	25	0	1	0~2000	毫秒 Millisecond

	Delayed start time for knife action						
P37	剪刀動作時間（全功率+維持功率） Knife action time (full power + maintain power)	110	90	10	1	10~2000	毫秒 Millisecond
P38	剪刀動作全功率時間 Full power scissors action time	80	80	80	1	10~990	毫秒 Millisecond
P39	剪線動作全功率時功率 Trimmer action full power	90	100	80	1	20~100	
P40	剪刀動作維持功率調整 maintain power adjustment for knife action	60	60	60	1	10~100	百分比 Percentage
P41	剪刀動作釋放保護時間 Knife action release the protection time	10	10	10	1	1~800	毫秒 Millisecond
P42	剪刀保護時間 Trimming protection time	1	1	1	1	0~5	秒 Second
P43	剪刀動作重定開關使能 Scissors action reset switch enable	1	1	1	1	0~1	0：禁用 1：啟用 0: Disable 1: Enabled
p44	下剪刀手動動作模式 Cutting manual action mode	0	0	0	1	0~1	0：禁用（縫製過程中結束或者用手轉動機器後，後踏不剪線） 1：啟用（縫製過程中結束或者用手轉動機器後，後踏可以剪線） 0: Disable 1: Enabled
P45	預留(剪線觸發模式) Reservation(trimming touch off mode)	1	1	1	1	0~1	
P46	撥線動作延時啟動時間 Wiper action delayed start time	70	70	145	1	0~2000	毫秒 Millisecond
P47	撥線動作時間（全功率+維持功率） Wiper action time (full power + maintain power)	55	55	55	1	10~2000	毫秒 Millisecond
P48	撥線動作全功率時間 Wiper action time at full power time	45	45	45	1	10~990	毫秒 Millisecond
P49	撥線動作全功率時功率 Wiper action full power	90	90	90	1	20~100	
P50	撥線動作維持功率調整 Wiper action time at maintain power adjustment	50	50	50	1	10~100	百分比 Percentage
P51	撥線動作釋放保護時間 Wiper action release the protection time	25	25	25	1	1~800	毫秒 Millisecond

P52	撥線動作保護時間 Wiper action protection time	3	3	3	1	1~5	秒 Second
P53	撥線動作保護開關使能 Wiper action protection switch enable	0	0	0	1	0~1	
P54	撥線動作模式 Wiper action mode	0	0	0	1	0~2	
P55	吹氣模式 Blow mode	10	10	10	1	5~3000	0：普通掃線 normal Sweep thread 1:剪一次吹一次 cut one time blow one time 2：每次抬壓腳都吹 Blow for each foot lifter 3：長吹 Long blowing 4：斷吹 break blow
P56	壓腳動作延時啟動時間 Foot-lifter action delayed start time	110	110	1	1	0~2000	毫秒 Millisecond
P57	壓腳動作時間（全功率+維持功率） Foot-lifter action time (full power + maintain power)	260	260	260	1	100~2000	毫秒 Millisecond
P58	壓腳動作全功率時間 Foot-lifter action time at full power time	160	160	160	1	100~990	毫秒 Millisecond
P59	壓腳全功率時功率 Presser foot full power	100	100	100	1	60~100	
P60	壓腳動作維持功率調整 Foot-lifter action time at maintain power adjustment	50	50	50	1	1~90	百分比 Percentage
P61	壓腳動作釋放保護時間 Foot-lifter action release the protection time	65	65	65	1	1~800	毫秒 Millisecond
P62	壓腳抬起後自動放下時間 Automatic presser foot lifter down time	10	10	10	1	1~120	秒 Second
P63	壓腳保護開關使能(步進原點檢測) Presser foot protection switch enable(stepper origin point detection)	1	1	1	0	0~1	
P64	壓腳動作模式 Presser foot action mode	0	0	0	1	0~1	
P65	半後踏抬壓腳延時啟動時間 Half-back step pedal foot lifter delay start time	150	150	150	1	0~2000	毫秒 Millisecond
P67	關閉掉電和過壓檢測 Low voltage and over voltage detection off	0	0	0	1	0~3	
P69	剪線釋放功率	0	0	0	1	0~55	

	Trimming releasing power						
P70	電機最大電流限制 Motor max electric current	350	350	350	10	50~600	
P71	最高速度鎖定 Maximum speed lock	4200	4200	4200	50	200~5500	轉 / 分鐘 Round / Minute
P72	系統密碼 System Password	2014	2014	2014	1	0~9999	
P73	語音音量 Voice volume	25	25	25	1	0~30	
P74	語言選擇 Language selection	0	0	0	1	0~1	0 中文 1 English
P76	吹氣動作延時啟動時間 Air-suction action delay starting time	140	140	140	1	0~2000	
P77	吹氣動作維持時間 Air-suction action maintain time	20	20	20	1	1~600	
P78	吹氣動作全功率時間 Air-suction action full power time	160	160	160	1	10~990	
P79	吹氣動作全功率時功率 Air-suction action full power	100	100	100	1	20~100	
P80	吹氣動作維持功率 Air-suction action maintain power	80	80	80	1	1~100	
P81	吹氣動作釋放時間 Air-suction action releasing time	45	45	45	1	1~800	
P82	吹氣動作保護時間 Air-suction action protection time	1	1	1	1	1~120	
P83	吹氣保護開關使能 Air-suction protection switch enable	0	0	0	1	0~1	
P84	吹氣動作 Air-suction action	0	0	0	1	0~4	0：關閉； 1：長吹； 2：斷吹，先吹後斷； 3：斷吹，和2相反； 4：抬壓腳吹 0: off; 1: long blowing; 2: blow at intervals: first blow 3: blow at intervals: first stop 4: blow after presser foot lifting
P85	吹氣模式	0	0	0	1	0~2	0：抬壓腳立即吹氣； 1：吹一次 2：吹二次 3：吹三次 4：吹四次 0：blowing after presser foot lifting 1: blow once 2: blow twice 3: blow three times 4: blow four times
P86	斷吹 ON 針數 Blow at intervals ON needle numbers	10	10	10	1	1~250	

P87	斷吹 OFF 針數 Blow at intervals OFF needle numbers	30	30	30	1	1~250	
P88	繡縫機機型選擇 Interlock machine mode selection	C007L 電動	C007L 氣動	C007L 步進	1	0~2	
P89	剪線計數 Trimming count	0	0	0	1	0~1	
P90	主介面顯示資料 Display on the main interface	0	0	0	1	0~4	0：關閉 1：計數 2：速度 3：腳控電壓 4：電壓 0: off 1:number count 2: speed 3: pedal voltage 4: voltage
P91	老化運行時間 Aging running time	5	5	5	1	1~60	
P92	老化運行停止時間 Aging running stop time	2	2	2	1	0~60	
P93	老化運行速度 Aging running speed	4500	4500	4500	100	200~5500	
P94	速度鎖定 Speed lock	5000	5000	5000	100	200~5500	
P95	虛擬速度 Virtual speed	100	100	100	50	0~5000	
P99	顯示幕版本號 Display version	1	1	1	1	0~9999	
P100	主控版本號 Controller version	505	505	505	1	0~9999	
P101	步進方向 Step direction	1	1	1	1	0~1	
P102	步進原點偏移量 Step origin offset	32	32	32	1	0~400	度
P103	步進原點功率 Step origin power	2	2	2	1	0~50	
P104	步進剪線功率 Step thread cutting power	85	85	85	1	5~95	
P105	步進剪線角度 Step thread cutting angle			900	1	1~1200	
P106	步進進刀速度 Step forward knife speed			800	1	1~1200	
P107	步進退刀速度 Step backward knife speed			500	1	1~1200	
P108	步進進刀力度 Step forward knife power			1	1	1~5	
P109	步進退刀力度 Step backward knife power			1	1	1~5	
P110	步進抬壓腳角度 Step motor presser foot lift angle			1500	1	1~1800	
P111	步進抬壓腳速度 Step motor presser foot lift speed			500	1	1~1200	

	Step motor presser foot lift speed						
P112	步進放壓腳速度 Step motor release presser foot speed			600	1	1~1200	
P113	步進抬壓腳力度 Step motor presser foot lift power			2	1	1~5	
P114	步進放壓腳力度 Step motor release presser foot power			1	1	1~5	
P115	05 型功能 05 mode function						
P116	05 型定針縫開關 05 mode fix needle sewing switch			0	1	0~1	
P117	05 型送料速度 05 mode feeding material speed			390			
P118	剪線開始減速行程 Trimming starting slow down itinerary			80	1	5~600	
P119	剪線開始減速速度 Trimming starting slow down speed			500	1	100~950	
P120	剪線回位元減速速度 Trimming back slow down speed			350	1	100~950	
P131	抬壓腳減速行程 Presser foot lifting slow down itinerary			100	1	5~1000	
P132	抬壓腳減速速度 Presser foot lifting slow down speed			200	1	100~1200	
P133	放壓腳減速行程 Presser foot releasing slow down itinerary			300	1	5~1000	
P134	放壓腳減速速度 Presser foot releasing slow down speed			100	1	100~1200	
P135	兩段式抬壓腳開關 Two paragraphs presser foot lifting switch			1	1	0~1	
P136	兩段式剪線開關 Two paragraphs trimming switch			0	1	0~1	

系統參數清單： System parameter list

四：控制箱埠說明：

The control box Port Description :

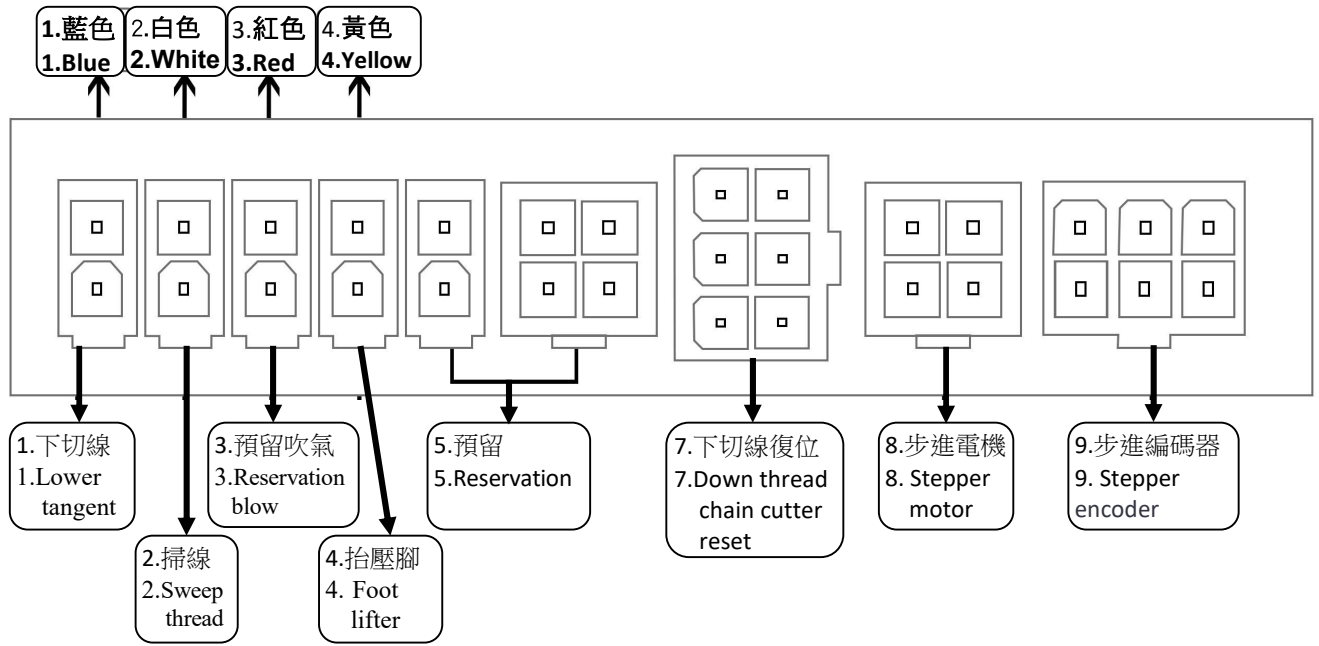

埠序號 The port number	埠連接的器件名稱 Port device name for the connection	埠說明 Port instruction		
1	下剪刀埠 Blow air port		2:1	2:霍爾輸入信號 hall input Signal 1:5V
2	撥線埠 Upper and lower scissors		2:1	2:吹氣輸出 blow output (800-2) 1:34V
3	安全開關 Presser foot output port		3:2:1	3:GND 2:霍爾輸入信號 hall input Signal 1:5V
4	步進電機埠 Safety switch		2:1	2:霍爾輸入信號 hall input Signal 1:5V
			3:2:1	3:GND 2:霍爾輸入信號 hall input Signal 1:5V

五：錯誤代碼解析 : Error code analysis

顯示的錯誤碼 Display error code	錯誤碼意思 Error code meaning	錯誤的產生 Various possible for the erro	解決錯誤 Solution
ER-01	找不到停針位 Not find needle position	1:手輪和電機靠的不夠近 2:手輪上磁鋼脫落 3:手輪磁鐵極性裝反 4:九針端子頭接觸不良 5:電機霍爾損壞,跟換電機 1: Hand wheel and motor 2 : Hand wheel magnet off 3: Hand wheel magnet polarity reversal 4: Nine-pin terminal head Poor contact 5: Motor hall damaged, with the change motor	1: 檢查電機信號線有無鬆動 2: 更換手輪 3: 更換電機 1: check whether the motor signal line is loose 2:replace the wheel 3: replace the motor
ER-02	腳踏板信號錯誤 Foot controller signal error	1: 開機時沒插調速器 2: 調速器插反 3: 調速器線斷開 4: 調速器損壞 1: Not plugged foot controller into control box 2: foot controller inserted upside 3: foot control box line broken 4: foot controller damage	1: 檢查調速器信號線 2: 更換調速器 3: 更換控制器 1: check the foot controller signal line 2: change the foot controller 3: replace the foot controller
ER-03	電機相位信號錯誤 Motor phase signal error	1: 九針插頭接觸不良 2: 電機安裝時霍爾和轉子存在大偏差 3: 電機霍爾壞 1: Nine-pin terminal plug Poor connect 2: Hall and rotor has large deviations when the motor is mounted 3: Motor hall damage	1: 打開電機上的橡皮蓋通過孔看電機轉子與定子是否在同一平面保障誤差不超過1MM 2: 更換電機 3: 更換控制器 1: open the rubber cover on the motor through the hole to see whether the motor rotor and stator in the same surface to ensure the error is not more than 1MM 2:replace the motor 3: replace the control box
ER-04	電機堵轉保護 Motor stall protection	1: 縫紉機過重或堵死 2: 電機超載 3: 電機 4 線驅動線沒連接好或插反 1: Sewing machine overweight or blocked 2: Motor overload 3: 4-wire motor drive cable is not connected or inserted upside	1: 檢查電機 4P 線 2: 檢查縫紉機是否過重 3: 更換控制器 1: check motor 4P line 2: check whether the sewing machine is too heavy 3: replace the controller
ER-05	硬體過流保護 Hardware over current	1: 縫紉機過重或堵死 2: 電機超載 3: 電機相位信號線沒連接好 4.功率管損壞 1: Sewing machine overweight or blocked 2: Motor overload 3: Motor phase signal line is not	

		connected 4: Power tube damage	
ER-07	串口通訊超時 Serial communication timeout	1：顯示幕連接主機板線連接不良 2：主機板晶片損壞 1: Display bad cable connection Motherboard 2: Motherboard chip damage	1：檢查顯示幕與控制器連接線 2：檢查控制器是否還可運行，如不能運行就是控制器損壞 3：檢查機器旁是否有高頻機器干擾 4：更換顯示幕 1:Check the connection line between the display screen and the control box. 2: check whether the controller run well, if not, controller damage 3: check whether there is a high frequency machine near the machine interference 4: change the display panel
ER-09	記憶體不良 Poor memory	1:主機板記憶體損壞或不良 1: Motherboard memory corruption or bad	1：控制器損壞 1: control box damage
ER-12	剪刀沒有復位報警 Knife is not reset the alarm	1：復位檢測器壞了 2：剪刀卡住沒復位 1: Reset the detector is broken 2: knife stuck not reset	1：檢查霍爾是否損壞 2：檢查感應磁鐵是否沒有感應到 3：檢查感應磁鐵磁極是否裝反 3. 更換電控 1： check the hall is damage or not 2:check whether the induction magnet is detected or not 3: check induction magnet pole is installed in reverse or not 4. change the control box
ER-15	編碼器故障 the motor board error		
ER-16	過壓 Over load	1.電機驅動電源電壓過高，220V 電源電壓超過限定值（AC310V），或負載慣性過大導至再生電壓超過限定值(DC440V),或電壓檢測回路故障。（110V 控制系統電源電壓超過限定值（AC155V），或負載慣性過大導至再生電壓超過限定值(DC220V)。 1. The motor drive power supply voltage is too high, the 220V power supply voltage exceeds the limit value(AC310V), or the load inertia is too large to the regenerative voltage exceeds the limit value(DC440V), or the voltage detection circuit fails.Note:(110V control system power supply voltage exceeds limit value(AC155V), or load inertia is too large to regeneration voltage exceeds limit value(DC220V).	
ER-20	欠壓故障 Under voltage error	1.電機驅動電源電壓過低，220V 電源電壓低於限定值（AC91V），或電機驅動電源電壓低於限定值（DC130V）,或電壓檢測回路故障。 注：（110V 電源電壓低於限定值（AC45.5V），或電機驅動電源電壓低於限定值（DC65V）） 1. The motor drive power supply voltage is too low, the 220V power supply voltage is lower than the limit value(AC91V), or the motor drive power supply voltage is lower than the limit value(DC130V), or the voltage detection circuit fails. Note:(110 V power supply voltage is below the limit(AC45.5 V), or motor drive power supply voltage is below the limit(DC 65V))	
ER-22	控速器故障 Speed controller error	前踩控速器開機 Step forward the speed controller when booting on	重新前踏解除 Troubleshooting with stepping forward the speed controller again.

		控速器故障 Speed controller failure	進入參數P24，查看腳控數值是否正常（200±15%），數值異常更換腳控 Enter the parameter P24, check the value of the speed controller if it is 200±15%, change a new one if the value abnormal.
ER-35	步進電機硬體過流保護 Stepper motor hardware over current	1:縫紉機過重或堵死 2:電機超載 3:電機相位信號線沒連接好 4:功率管損壞 1:Sewing overweight or blocked 2:Motor overload 3:Motor phase signal line is not connected 4:Power tube damage	1:檢查步進電機連接線 2:檢查步進電機是否卡死 3:更換電控 1:check stepper motor connection 2:check whether the stepper motor stuck or not 3:replace the controller
ER-37	A 相電流檢測故障 A phase current detection error	更換電控 Change a controller box	
ER-38	B 相電流檢測故障 A phase current detection error	更換電控 Change a controller box	
ER-39	B 相電流檢測故障 A and B phase current detection error	更換電控 Change a controller box	
ER-45	步進電機編碼器故障 Stepper motor encoder error	更換步進電機編碼器 Change the encoder of the stepper motor	
ER-46	步進電機開機原點未復位 The starting point of stepper motor is not reset	檢查步進結構有無安裝錯誤，松掉固定螺絲後，重啟電源是否繼續報警 Check if the stepper structure installing mistake or not, if it still shows error when releasing the fixed screw.	

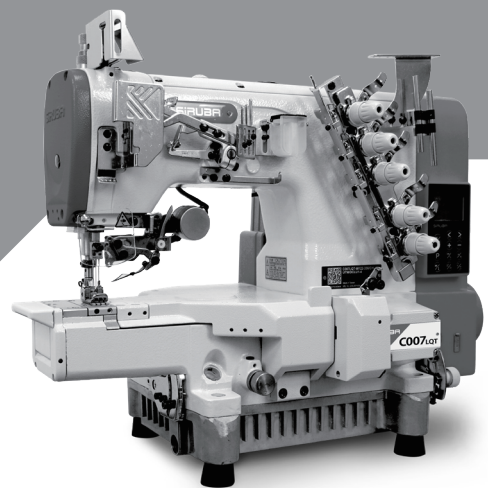

高林股份有限公司
KAULIN MFG. CO., LTD.

由於對產品的改良及更新，本產品使用說明書中與零件圖之產品及外觀的修改恕不事先通知！
The specification and/or the equipment described in the instruction book and parts list
are subject to change because of modification with out previous notice
C007LQT.SEP.2023