

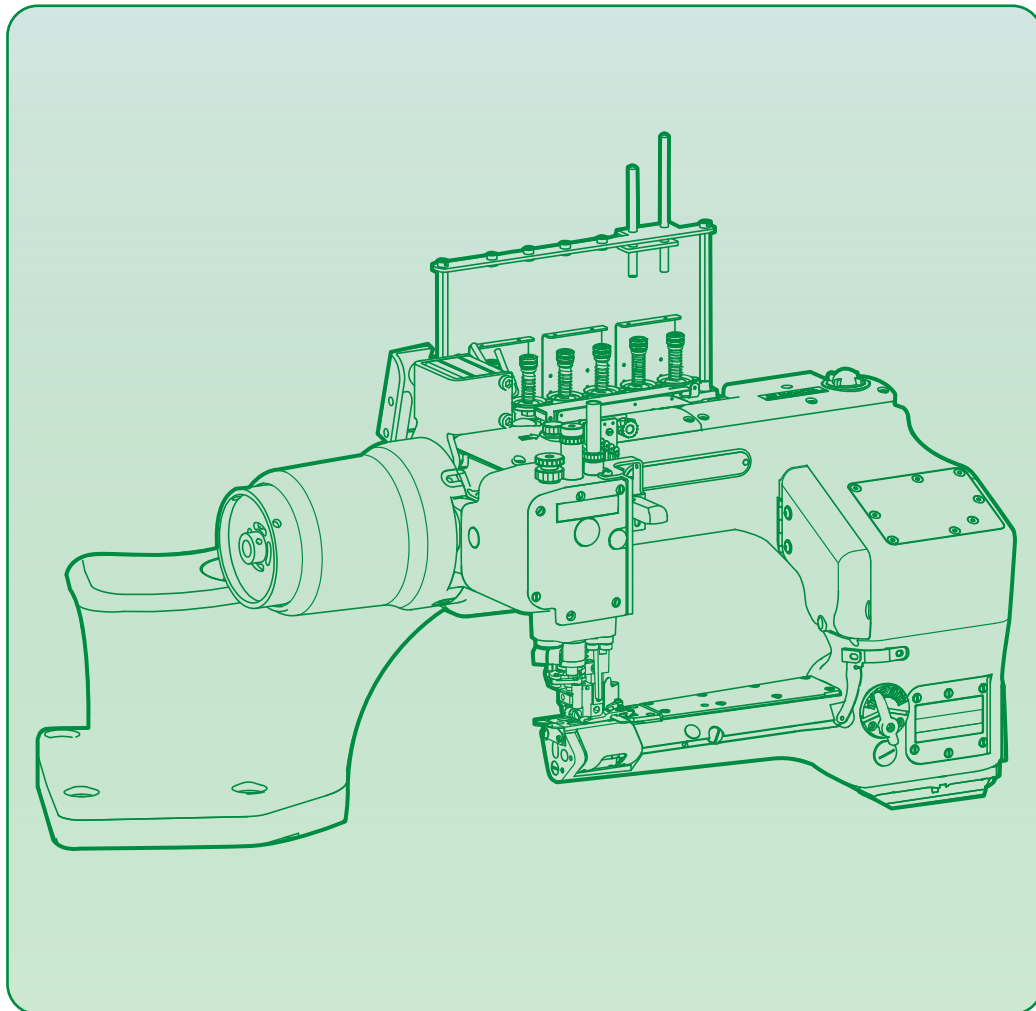

**MEGASEW**

Industrial sewing machine



# MJ101TX

## 使用 & 維修手冊

## INSTRUCTION BOOK

名匠縫紉機股份有限公司

MING JANG SEWING MACHINE CO.,LTD.

# CONTENTS

Safety introduction

i-iv

<b>1. Name of each part</b>	<b>各部份名稱</b>	<b>1</b>
<b>2. Installation</b>	<b>安裝</b>	<b>2</b>
2.1 Installation	安裝	2
2.1.1 Tabletop type	桌板尺寸	2
2.1.2 Installing machine head	車頭安裝	3
2.2 Adjusting Presser foot lift	調整抬壓腳	4
2.2.1 Presser foot lift	抬壓腳	4
2.2.2 Tension release unit	過線組	6
2.3 Other parts	其它部份	7
<b>3. Sewing speed and direction of hand wheel</b>	<b>馬達轉速&amp;手輪轉動方向</b>	<b>8</b>
<b>4. Lubrication</b>	<b>潤滑</b>	<b>9</b>
4.1 Lubricating oil	潤滑油	9
4.2 Lubricating	潤滑系統	9
4.3 Refilling oil	補充油	10
4.4 Changing oil	更換油	11
<b>5. Proper operation</b>	<b>使用說明</b>	<b>12</b>
5.1 Needle system	車針系列	12
5.2 Installing needle	針的安裝	13
5.3 Threading	穿線	14
5.4 Thread tension	線鬆緊	15
5.5 Pressure of presser foot	調整壓腳壓力	15
5.6 Up-and-down position of presser foot	調整壓腳高低	16
5.7 Adjusting differential feed dog	調整差動	17
5.8 Adjusting stitch length	調整針距	18
5.9 Adjusting lapped width of upper fabric	調整切布刀	19
5.10 Sp device	過線油組	20
5.11 Use of lap former	導布器	21

# CONTENTS

---

<b>6. Adjustments</b>		<b>調節裝置</b>	<b>22</b>
6.1	Needle thread tension	打線組	22
6.2	Looper thread tension	下底線	24
6.3	top cover thread tension	上網線	25
6.4	Height of needle	針位高度	26
6.5	Looper	下勾針	27
6.6	Needle guard (front)	前針檔	29
6.7	Needle guard (rear)	後針檔	30
6.8	Top cover thread carrier and hook	上撥線架	31
6.9	Height of feed dog	勾齒高度	32
6.10	Replacing presser foot	置換壓腳	34
6.11	Replacing presser foot spring plate	置換壓腳彈片	37
6.12	Replacing and adjusting knives	置換和調整刀片位置	38
<b>7. Specifications</b>		<b>規格</b>	<b>40</b>

# 1. Name of each part

# 各部份名稱

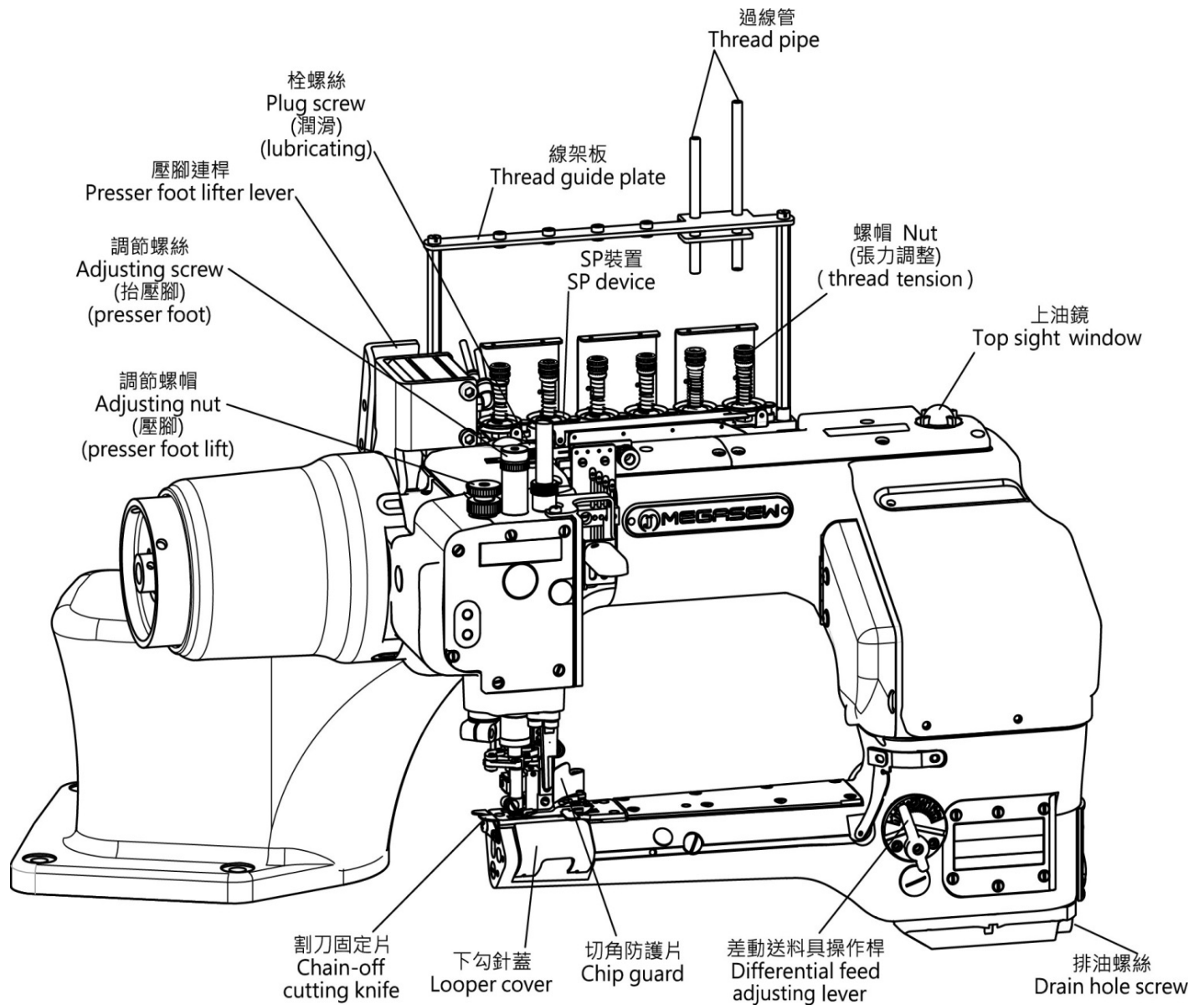

Fig. 1

## 2.1 Installation

### 2.1 安裝

#### 2.1.1 Tabletop type

##### 2.1.1 桌板尺寸

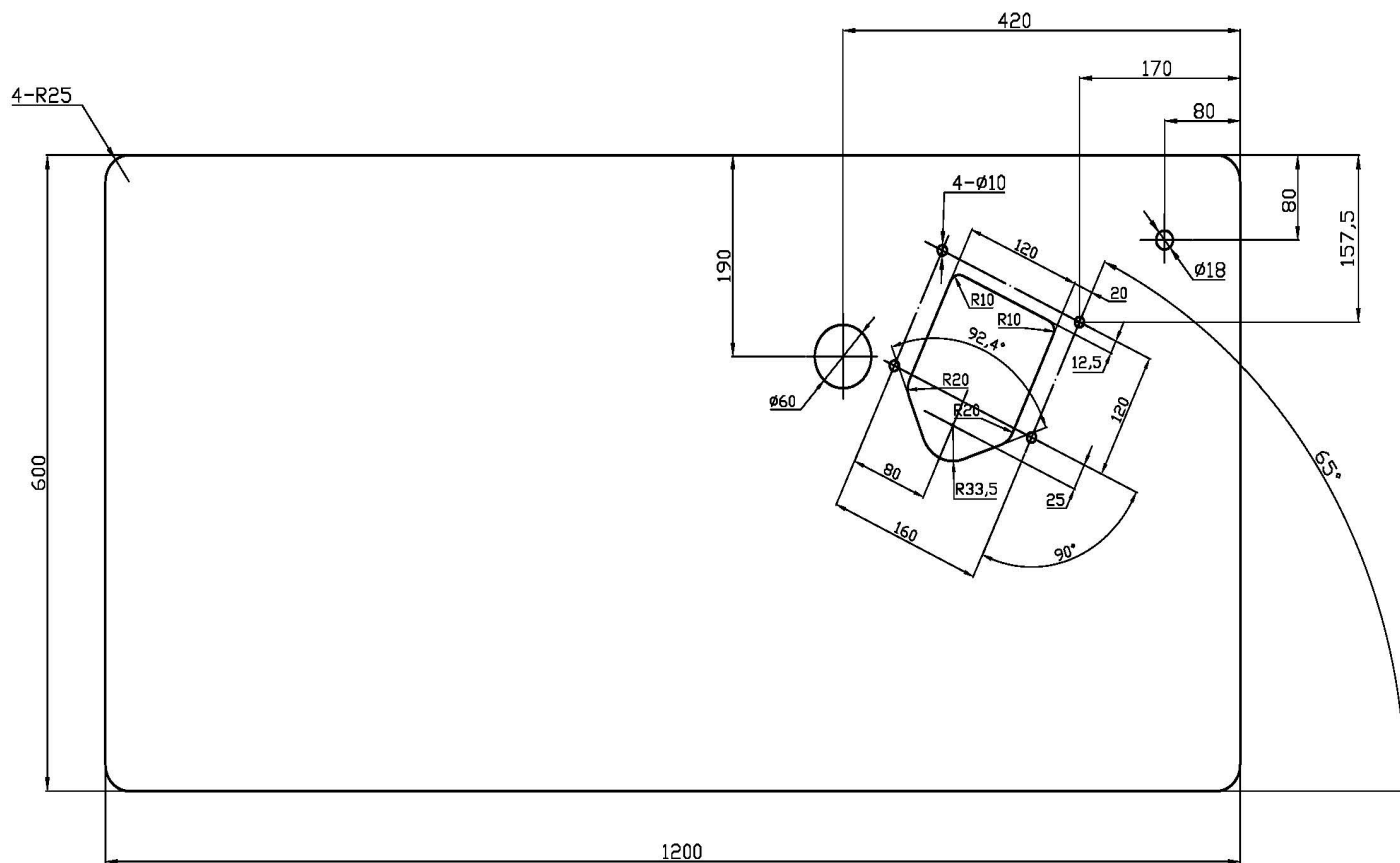

Fig. 2

### 2.1.2 Installing machine head

#### 2.1.2 車頭安裝

Install a sewing machine on the sewing machine supporting block with two screws. (Fig.3)

組裝縫衣機到支撐塊上面要用2顆螺絲。(圖3)

## WARNING

If the machine falls down or turns over, damage will occur.

Always arrange two persons or more to install the machine.

## 注意

如果機器翻倒，它會發生損害。避免機器的損壞  
安裝機器時必需2人以上。

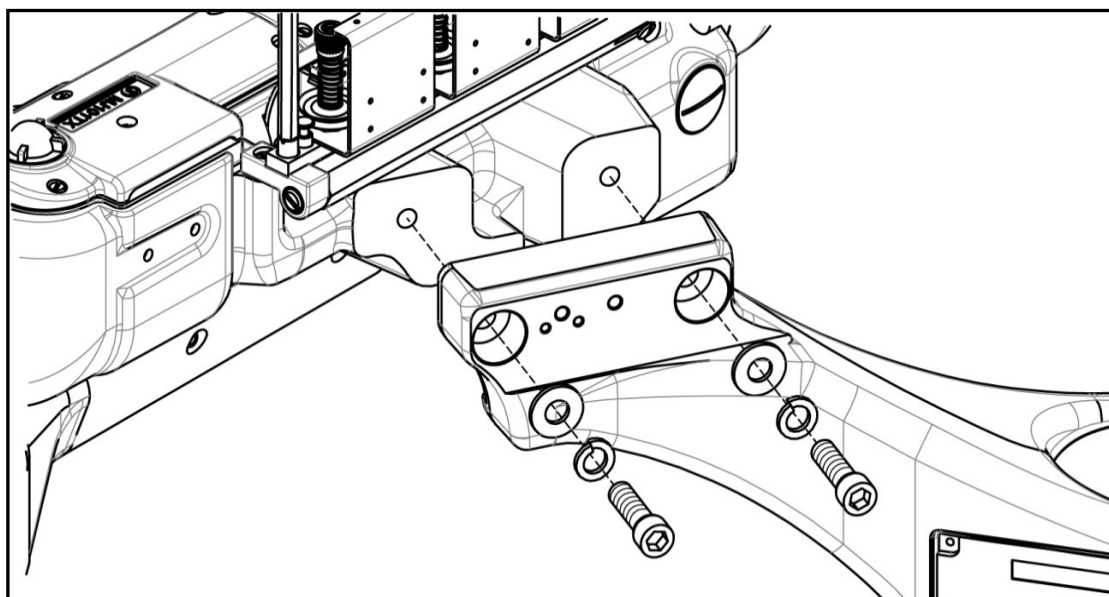

Fig. 3

When installing the machine, use 2 screws, 2 flat washers and 2 spring washers to fix. (Fig. 4)

安裝縫紉機時，用2顆螺絲及墊片固定。(圖4)

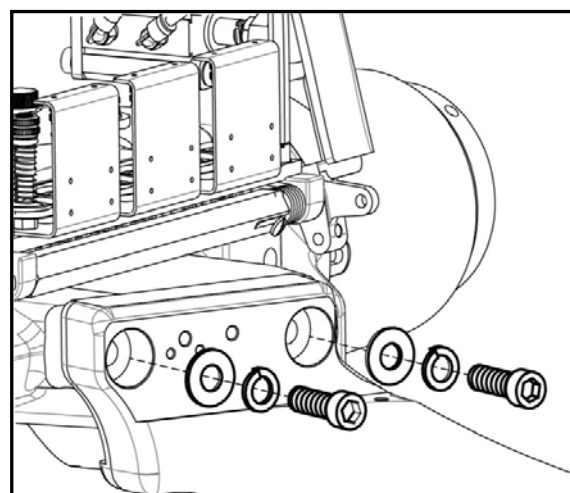

Fig. 4

## WARNING

Before starting operation, unplug the motor's power cord from the outlet.

## 注意

操作前，請先關閉電源。

## 2.2 Adjusting presser foot lift

### 2.2 調整抬壓腳

#### 2.2.1 Presser foot lift

##### 2.2.1 抬壓腳

1. Make sure to leave a clearance between the presser bar lifter lever ① and the presser bar connecting bracket ② to 1 mm when the presser foot closely touches the stitch plate. (Fig. 5)

Note: The clearance between the body of the presser foot and presser foot spring plate is 0.3mm.

1. 當壓腳緊貼在針板上時，在抬壓腳連接軸 ① 跟壓腳連接托架 ② 留1mm的間隙。(圖5)  
註：壓腳主體跟壓腳彈片之間要有0.3mm的間隙。

#### Adjusting :

- (1) Remove the seal plugs ③ and ④ to check the above-said clearance. (Fig. 6)
- (2) Loosen the screw ⑤ of the presser foot lifter lever link (long).(Fig. 7)
- (3) Move the presser foot lifter lever link (long) ⑥ right or left to adjust the clearance.(Fig. 7)

#### 調整：

- (1) 移除油塞③ ④才可以檢查間隙。(圖 6)
- (2) 放鬆壓腳連接桿螺絲 ⑤。(圖7)
- (3) 左右移動壓腳連接桿(長)⑥去調整間隙。(圖 7)

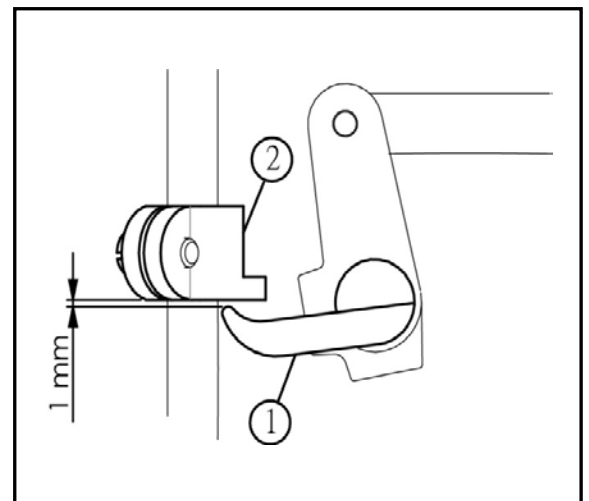

Fig. 5

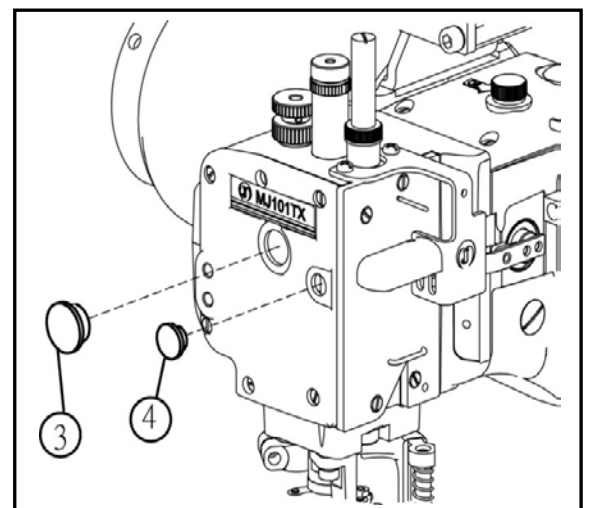

Fig. 6

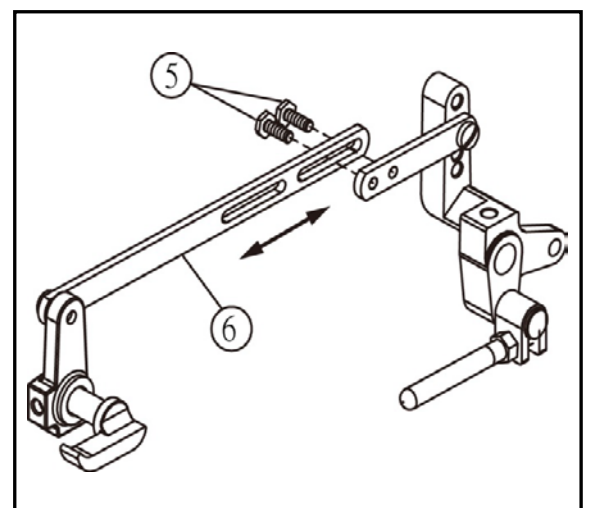

Fig. 7

## CAUTION

After adjusting the clearance of the presser bar lifter lever ①, adjust the presser foot lift when presser bar is located at the lowest position.

If this is not adjusted, damage can probably be caused to top cover thread hook. (Fig. 8)

## 注意

在調整抬壓條連接軸 ① 之後，調整抬壓腳在壓腳的最低位置。

如果此項調整沒作，會導致上網線勾損壞。

(圖8)

2. Make sure to keep a clearance between the notch of the needle clamp ① and the top cover thread hook ② at 0.3mm when the needle bar is at the lowest point, and the presser foot is fully raised by pressing foot pedal. (Fig. 9)

2. 當針柱在最低位置和壓腳完全抬舉時，針鉗 ① 和上網線勾 ② 需留間隙 0.3mm。(圖 9)

## Adjusting :

- (1) Loosen the lock nut ③ .
- (2) Move the preseer foot lifter stop plunger ④ in or out to adjust the clearance. (Fig. 10)

## 調整：

- (1) 放鬆螺母 ③。
- (2) 移動抬壓腳固定插銷 ④ 往內或往外來調整間隙。(圖 10)

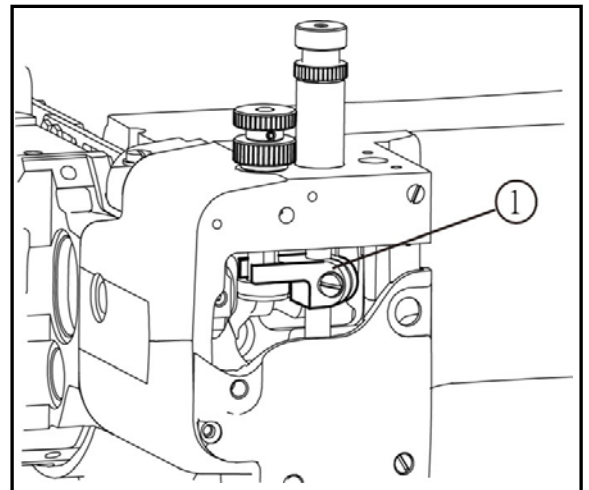

Fig. 8

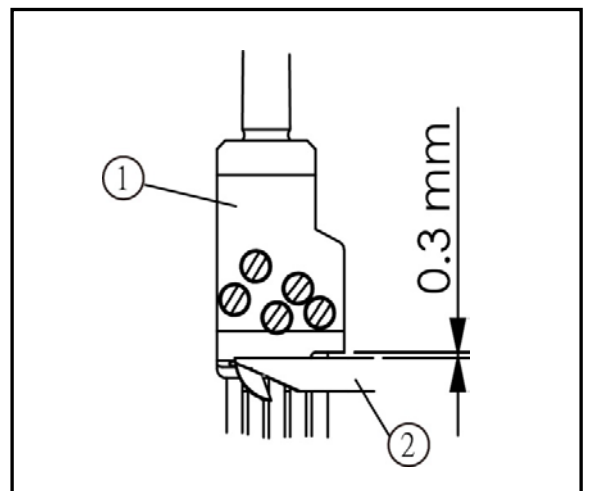

Fig. 9

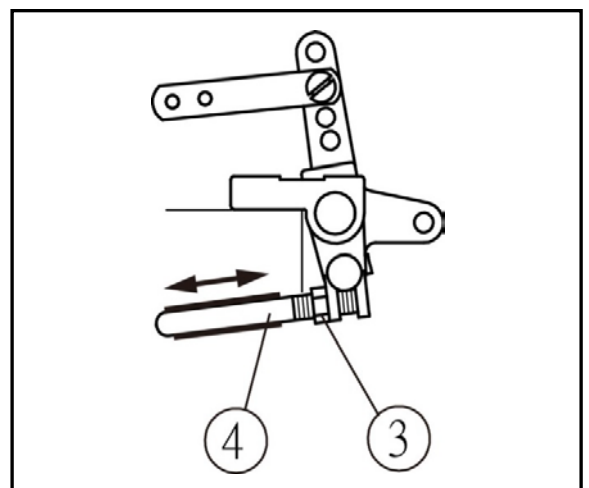

Fig. 10



## 2.2.2 Tension release unit

### 2.2.2 過線組

Make sure to keep a clearance between the tension release pins ① and the tension release shaft ③ at 0.5mm when six tension release pins ① are pushed up slightly and the upper thread tension disc ② starts parting from the lower thread tension disc without pressing the presser foot pedal. (Fig. 11)

不踩踏板時凸線器 ① 和凸線器座 ③ 之間要有 0.5mm 的間隙。

當踩下踏板時，六個凸線器 ① 會向上推，然後夾線片 ② 開始離開下夾線片。(圖11)

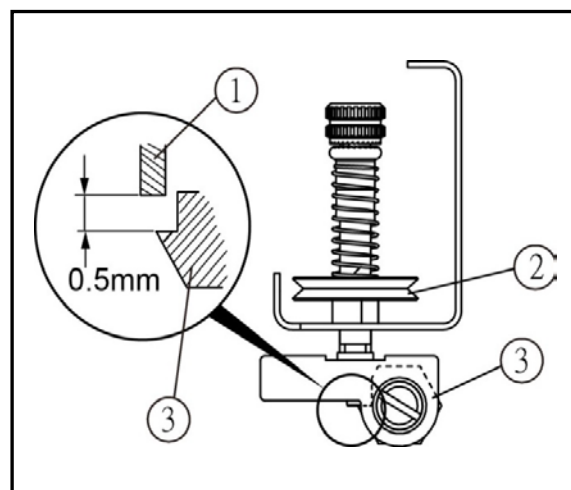

Fig. 11

### Adjusting :

- (1) Loosen the screw ④ of the presser bar lifter lever (large).(Fig. 12)
- (2) Turn the tension release shaft ③ with a screwdriver. (Fig. 11)

- Turn it clockwise to reduce the clearance.
- Turn it counterclockwise to increase the clearance.

### 調整：

- (1) 放開提昇擺臂(大)的螺絲 ④。(圖12)
- (2) 翻轉凸線器座 ③ 用螺絲起子。(圖 11)

- 順時針旋轉去減少間隙。
- 逆時針旋轉去增加間隙。

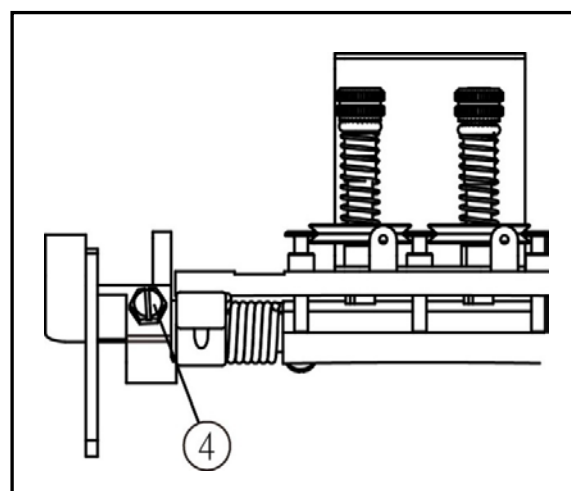

Fig. 12

## 2.3 Other parts

### 2.3 其它部份

#### Setting thread eyelets :

Place the thread guide plate supports ③ on the thread tension support ⑦ and fix the thread guide plate ④ on the supports ③ with the screws ⑤.

Adjust the thread pipes ⑥ to make sure threads get through smoothly without being entangled. (Fig. 13)

#### 安裝機頭線架：

將線架支柱 ③ 裝在線架固定座 ⑦，再將過線架 ④ 用螺絲 ⑤ 鎖在線架支柱 ③ 調整過線管 ⑥，使穿線平順，不致於線會糾結在一起。(圖13)

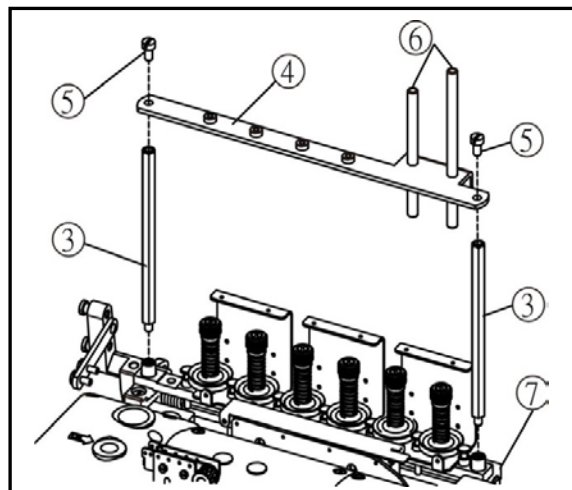

Fig. 13

### 3. Sewing speed and direction of hand wheel

#### 馬達轉速和手輪輪轉動方向

3000 RPM is regular sewing speed, and 4000 RPM is maximum sewing speed.

Run a new machine at a speed of 15-20 % lower than maximum sewing speed during the first 200 hours (for about one month) so that the machine can last longer in good condition.

The rotation of the motor pulley (hand wheel) ① is in clockwise direction from the operator side. (Fig.14)

機器轉速平常使用3000轉，而4000轉為最高速。新機器在前200個小時(約一個月左右)使用2650 - 2800的轉速，這樣可以延長機器使用壽命。

手輪 ① 的運轉方向從作業員的角度是順時針。(圖14)

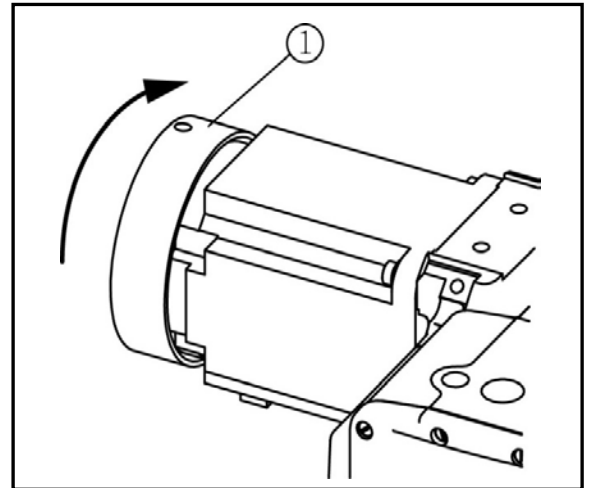

Fig. 14

#### CAUTION

**If rotating in reverse direction, oil can not be provided properly, and the machine will be probably damaged.**

#### 注意

如果運轉方向相反，油無法供應，會造成機器損壞。

## 4.1 Lubricating oil

### 4.1 潤滑油

#### CAUTION

NEVER add additives to the oil.

If added, it can cause the deterioration of the oil and damage to the machine.

#### 注意

絕對不要在油內再加人任何添加物(劑)，否則將惡化油的品質並損害機器。

## 4.2 Lubricating

### 4.2 潤滑系統

Remove the plug screws ① and ② indicated " OIL " and pour in oil.

From the plug screw ①, pour in oil until the oil indicator ③ reaches the upper line. Form the plug screw ②, pour oil in until the oil level reaches the upper line in the oil sight gauge ④.

Check the oil level between the lines in the oil sight gauges ③ and ④ before running a machine.

If the oil level is under the lower line, refill oil.

Check the oil splashes from the nozzle inside the oil sight gauge top windows ⑤ and ⑥ when starting to run a machine. (Fig. 15 & 16)

旋開油塞螺絲 ① 和 ② 然後加油。

從油孔 ① 加油直到油量到 ③ 最上方的紅線，  
從 ② 加油直到油量到 ④ 最上面的紅線。

使用機器前檢查油水平。如果沒到水平線要加油。  
當機器在使用中時，檢查油有無供應從油鏡 ② 和 ⑤。(圖15 & 16)

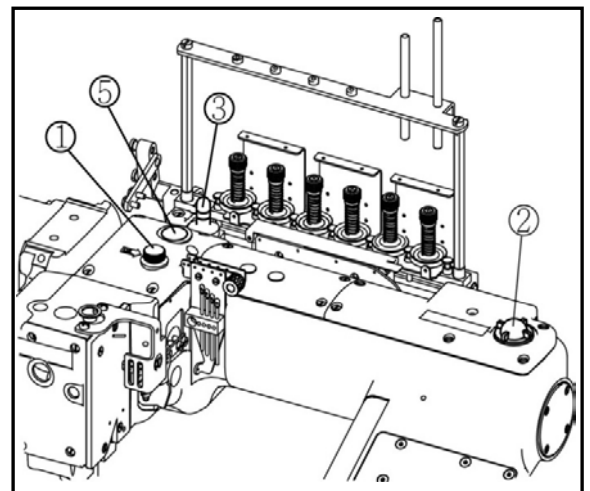

Fig. 15

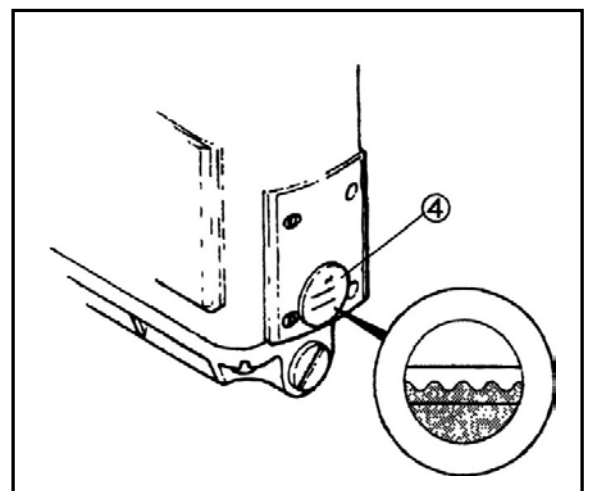

Fig. 16

**CAUTION**

Too much oil or not enough oil can cause oil leakage and/or damage to machine . Be sure to keep the oil level between two red lines.

**注意**

太多或太少的油會造成機器漏油和機器故障。維持油的水平在2條線之間。

**4.3 Refilling oil****4.3 補充油**

Replenish with an oiler a drop of oil at the points indicated with arrows.

If excessive oil left around the presser foot and the upper knife, material can be stained unexpectedly. Be sure to wipe it out completely. (Fig. 17, 18 & 19)

用油壺在箭頭處滴一滴油來潤滑。但如果使用過多，而讓油滴濺在壓腳和上刀周圍，會導致布受油染汙。要確實把多餘的油擦乾淨。(圖17,18 & 19)

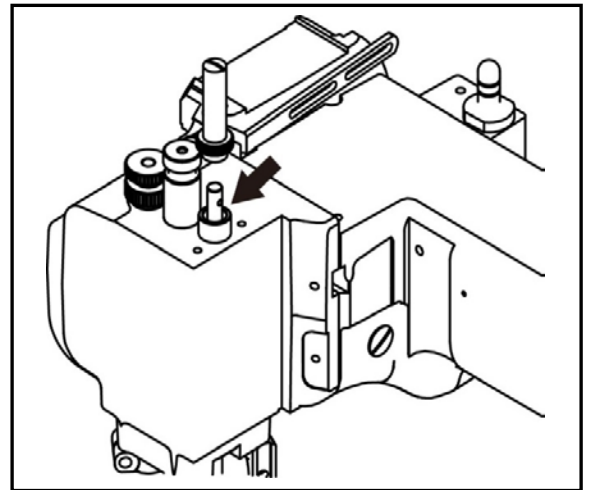

Fig. 17

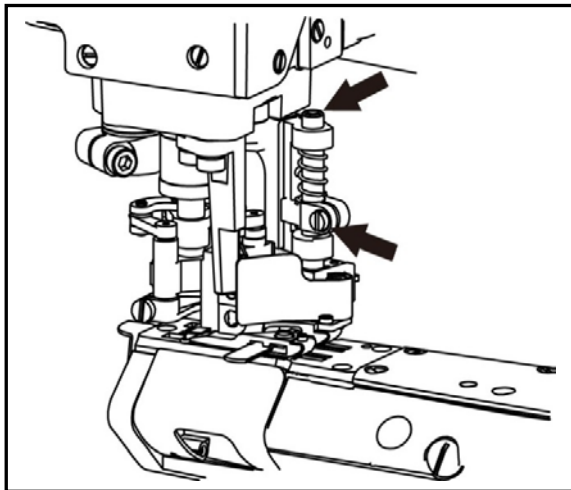

Fig. 18

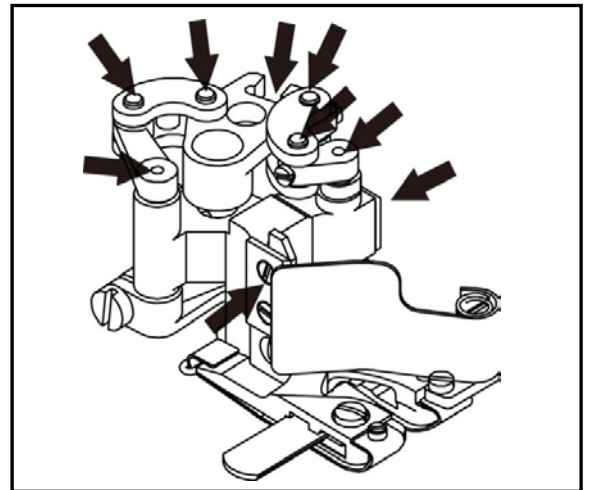

Fig. 19

**CAUTION**

If too much oil lubrication is applied, material can be stained.

**注意**

太多的潤滑油會使布料沾汙。

## 4.4 Changing oil

### 4.4 更換油

#### Period of changing :

When using a new machine, change the lubricating oil after running for 200 hours (for about one month). After that, change the oil once or twice a year.

#### 換油時機：

新機使用200小時(約使用一個月)後，要更換新油，之後，每年換新油1~2次。

#### Procedure for changing :

- (1) Put oil containers under the screws ① and ②.
  - (2) After removing screws ① and ②, drain oil respectively.
  - (3) Reset the screws ① and ②.
  - (4) Refill the new oil. (See "4.2 Lubrication")
- (Fig. 20 & 21)

#### 換油程序：

- (1) 分別在螺絲 ① ② 下面放置接油容器。
  - (2) 拆下螺絲 ① 和 ② 後，讓舊油完全流出。
  - (3) 裝回螺絲 ① 和 ②。
  - (4) 注入新油。(參考"4.2 潤滑系統")
- (圖20 & 21)

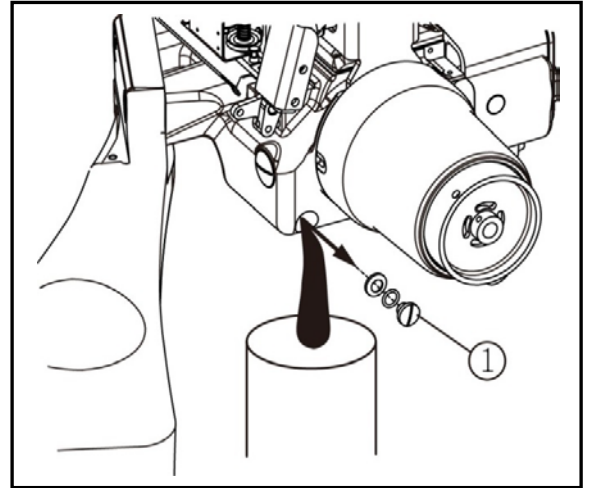

Fig. 20

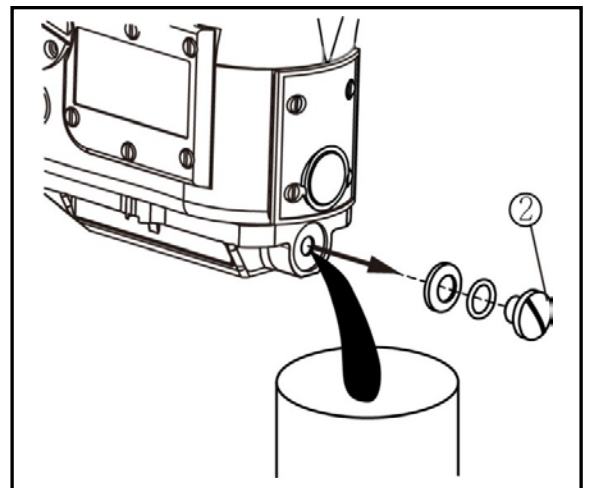

Fig. 21

## 5.1 Needle system

### 5.1 車針系列

#### Sewing needle :

TNC	FLX118GCS
Organ	FLX118GCS
Groz-Beckert	UY118GKS

Select the proper-sized sewing needle depending on thickness and type of fabrics. (Table 2)

<b>Japanese Standard</b> 日本規格	8	9	10	11	12	-	14
<b>Metric Standard</b> 公制規格	60	65	70	75	80	-	90

Table 2

Note : Some needles are not available in size.

Check the size in needle manufacturer's catalog.

提醒：有些尺寸的車針並沒有販售，請查核針供應商之目錄上來確認尺寸。

#### 縫紉機用針：

德富牌	FLX118GCS
風琴牌	FLX118GCS
格洛茲貝克牌	UY118GKS

針對不同的布料材質及厚薄選用適合的車針。  
(表2)

#### Retainer needle :

One retainer needle is used together with four sewing needles.

TNC	FLG-2, FLG-1, FLG-8 (with scarf)
Organ	FLG-2, FLG-1, FLG-8 (with scarf)
Groz-Beckert	36211, 36211A (with scarf)

Select the proper-sized retainer needle depending on thickness and type of fabrics. (Table 3)

<b>Japanese Standard</b> 日本規格	8	9	10	11	12
<b>Metric Standard</b> 公制規格	60	65	70	75	80

Table 3

Note : Some retainer needles are not available in size.

Check the size in needle manufacturer's catalog.

提醒：有些尺寸的車針並沒有販售，請查核針供應商之目錄上來確認尺寸。

#### 假針：

一支假針配合四支針。

德富牌	FLG-2, FLG-1, FLG-8
風琴牌	FLG-2, FLG-1, FLG-8
格洛茲貝克牌	36211, 36211A

針對不同的布料的性質及厚薄來選擇適合的假針。  
(表3)

## 5.2 Installing needle

### 5.2 針的安裝

#### WARNING

Before installing the needles, ALWAYS turn OFF the power switch and check that the motor has already stopped.

#### 注意

安裝針之前，一定要先把電源關掉，並確認馬達已完全停止不動。

Insert needles into the inmost point of the needle clamp, and tighten screws ①. (Fig. 22)

將針插到針鉗的最頂端然後鎖緊螺絲 ①。  
(圖22)

#### Replacing needle :

- (1) Rotate the handwheel to raise the needles to the highest point.
- (2) Loosen the screws ① and pull the needles down.
- (3) Make the flat part of Needles face to the front, insert new needles into the needle clamp ② as far as they can go. Tighten screws ① securely. (Fig. 22)

#### 替換針：

- (1) 旋轉手輪將針抬到最高點。
- (2) 放鬆螺絲 ① 把針拔下來。
- (3) 將車針平面朝前，再將新針放入針鉗 ② 孔內最頂端，然後鎖緊螺絲①。(圖22)

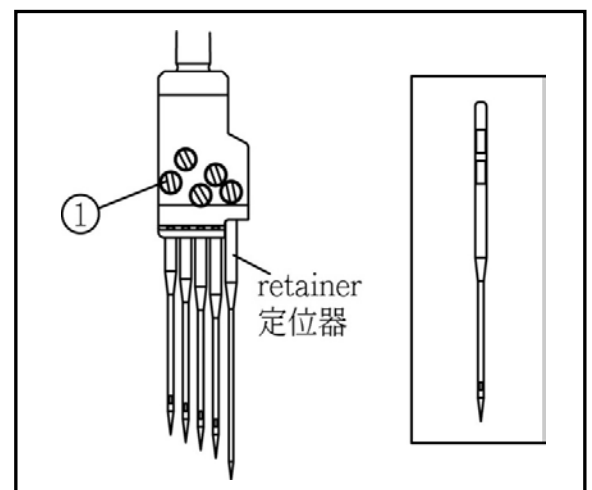

Fig. 22

#### WARNING

Before threading, ALWAYS turn OFF power switch and make sure the motor has already stopped.

#### 注意

穿線前，一定要先把電源關掉以及確認馬達完全停止不動。



## 5.3 Threading

### 5.3 穿線

Refer to Fig. 23 to conduct threading correctly.

A, B, C, D Needle threads ... When threading, pull the thread out until they reach the needle clamp. Then cut off the thread knot and rethread through needle eye.

E : Top cover thread When threading up here, cut off the thread knot and conduct the threading.

F : Lower looper thread

正確穿線，參考圖23

A, B, C, D 針線 先用易穿的線從ABCDEF孔穿至針鉤前，然後結上要用的線拉到針前把結剪掉。

E : 上打網線

F : 下勾針線

當穿線至此時，把線結剪掉，再穿入針孔。

### TIP

When raising presser foot, thread tension will be evenly released, and threading through take up can be smoother.

### 小提醒

當抬起壓腳時，線架組會平穩的放開，如此穿線至凸輪會順暢些。

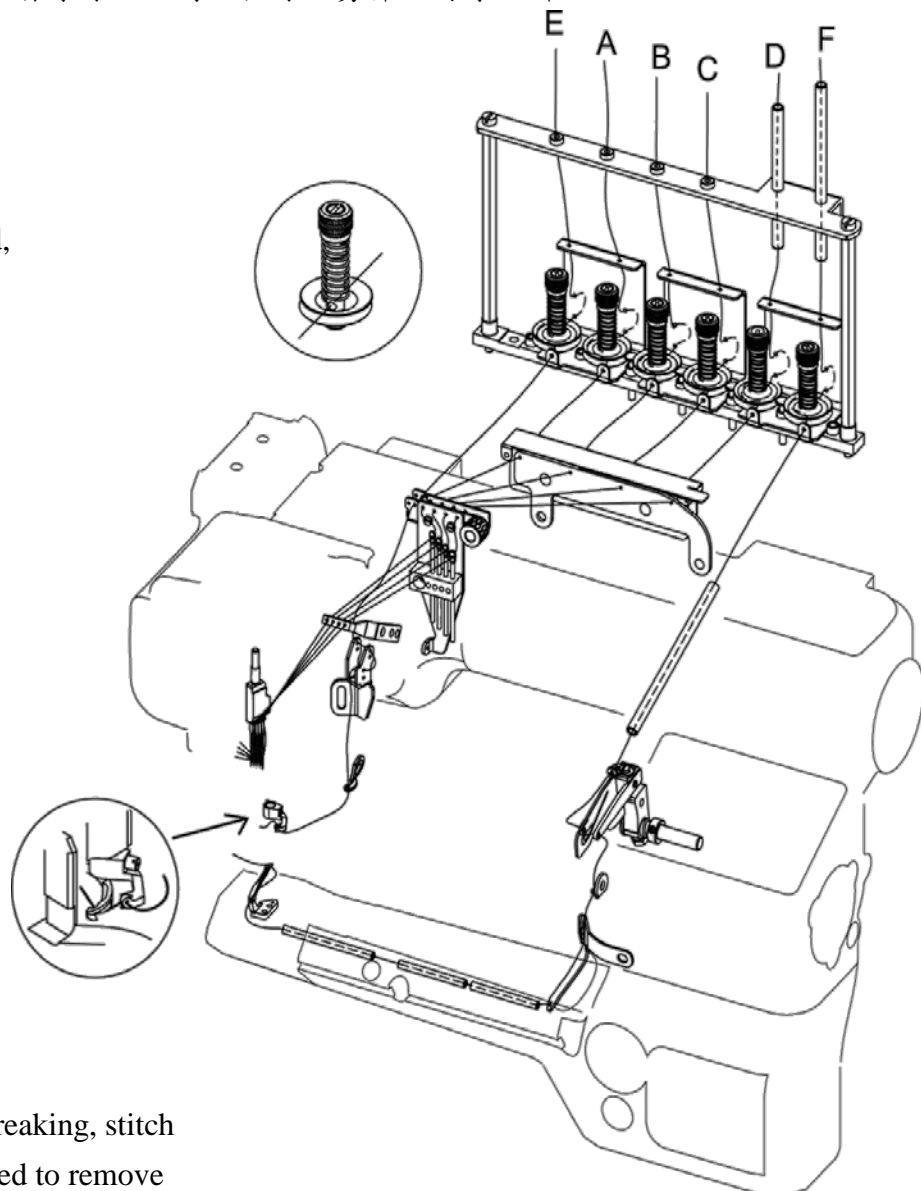

Fig. 23

### NOTE

Inproper threading can cause thread breaking, stitch skipping, and uneven stitching. No need to remove needle plate when conducting lower looper threading.

提醒：不當的穿線會導致斷線、跳針、線跡不整。穿下鉤針線時不須把針板拆掉。

## 5.4 Thread tension

### 5.4 線鬆緊

Thread tension can be adjusted through the tension nuts ① - ⑥ depending on the material of fabric and the type of thread, seam width, stitch length, and other sewing conditions. (Fig. 24)

① - ④ : needle threads

(① : right needle, ④ : left needle)

⑤ : top cover thread

⑥ : looper thread

● To tighten the thread tension, turn the nuts ① - ⑥ clockwise.

● To loosen the thread tension, turn the nuts ① - ⑥ counter-clockwise.

● 如果調緊線時以順時間方向調下 ① - ⑥ 螺絲。

● 如果調鬆線時以逆時間方向調上 ① - ⑥ 螺絲。

調整線架上的鬆緊度是靠螺母 ① - ⑥ 取決於布及線之材質、針寬、針距和其它車縫狀況。(圖24)

①-④：針的線

(①：右針，④：左針)

⑤：上網線

⑥：下網線

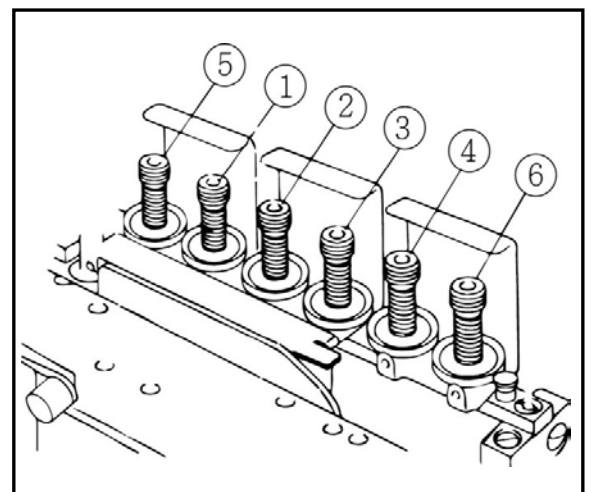

Fig. 24

## 5.5 Pressure of presser foot

### 5.5 調整壓腳壓力

Loosen the lock nut ⑦ and turn the adjusting screw ⑧ to adjust the pressure. (Fig. 25)

● To increase the pressure, turn the adjusting screw ⑧ clockwise.

● To reduce the pressure, turn the adjusting screw ⑧ counterclockwise.

Keep the pressure as low as possible for stable and smooth stitching.

儘可能保持壓腳壓力在最鬆的狀態使布在針板上更加平穩。

放鬆螺母 ⑦ 然後用壓腳柱螺帽 ⑧ 來調壓力。(圖25)

● 欲增加壓腳壓力時，順時間調整螺帽 ⑧。

● 欲減少壓腳壓力時，逆時間調整螺帽 ⑧。

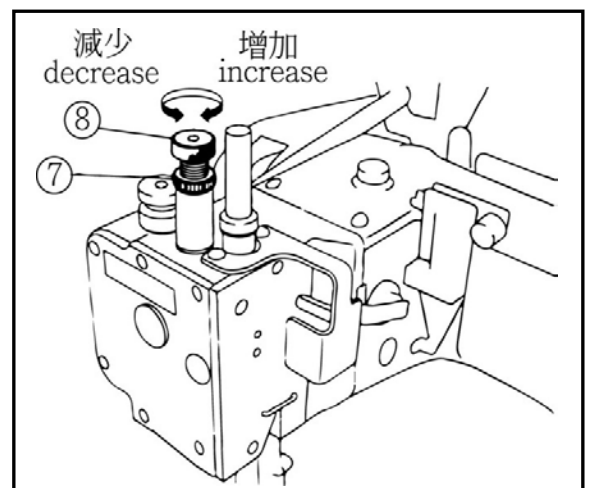

Fig. 25

## 5.6 Up-and-down position of presser foot

### 5.6 調整壓腳高低

Following effects can be obtained by slightly raising or lowering the presser foot.

輕微的調高或降低壓腳都會下列明顯的成效。

- To avoid fabric jam
- To avoid feed scratch mark
- To enhance durability of presser foot spring plate
- To increase or reduce presser foot pressure
- To reduce vibration and noise
- For fine adjustment of lapped fabric width

- (1) Position the needle at the lowest point.
- (2) Loosen the lock nut ① and turn the adjusting nut ② counterclockwise to raise the presser foot.
- (3) Adjust the clearance between the bottom ④ of the presser foot and the presser foot spring plate ③ to 0.3-0.5 mm.
- (4) Tighten the lock nut ① securely. (Fig. 26 & 27)

- 預防布料糾結
- 預防勾齒抓痕
- 改善壓腳彈片的耐久度
- 增減壓腳彈簧片的壓力度
- 減少噪音和振動
- 可細微的調整針織的寬度

- (1) 針在最底點的位置。
- (2) 鬆開螺絲 ① 然後逆時旋轉調整螺母 ② 抬起壓腳。
- (3) 在壓腳 ④ 和壓腳彈片 ③ 之間調整出口 0.3-0.5 mm 的間隙。
- (4) 把螺母 ① 鎖回去。(圖26 & 27)

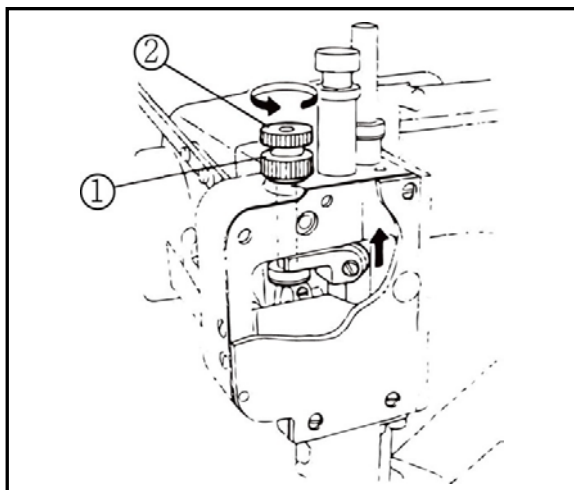

Fig. 26

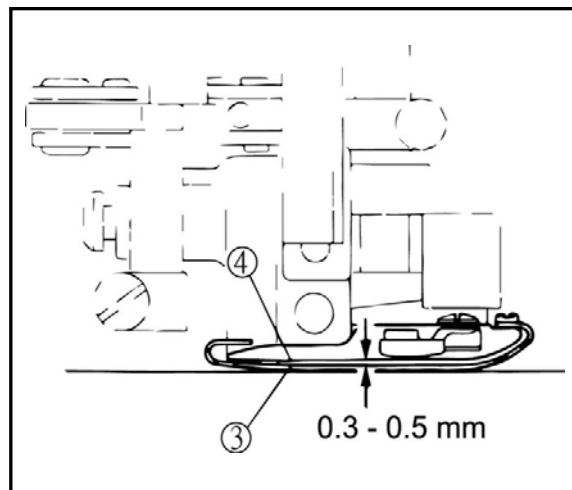

Fig. 27

## 5.7 Adjusting differential feed dog

### 5.7 調整差動

Move the main and / or the differential ratio feeding lever

⑤ right or left to adjust the feeding ratio.

移動調整桿 ⑤ 向右或左去調整差動行程大小。

When the lever ⑤ is set between the scale "4" and scale "5", the movement of the main feed dog and the differential feed dog will be equal. (Fig. 28)

差動比調整桿 ⑤ 定位在刻度"4"與"5"之間時，主牙與差動牙的運作相同。(圖28)

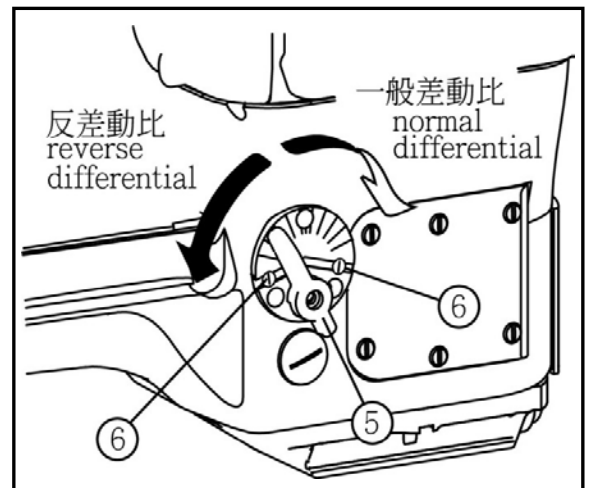

Fig. 28

### Adjusting Main Feeding Ratio (Fig.29)

● To increase main feeding ratio, move the lever ⑤ backward to scale "1".

● To decrease main feeding ratio, move the lever ⑤ forward to scale "9".

### 調整主齒差動 (圖. 29)

● 增加主齒差動時將調整桿 ⑤ 往刻度"1"的方向。

● 減少主齒差動時將調整桿 ⑤ 往刻度"9"的方向。

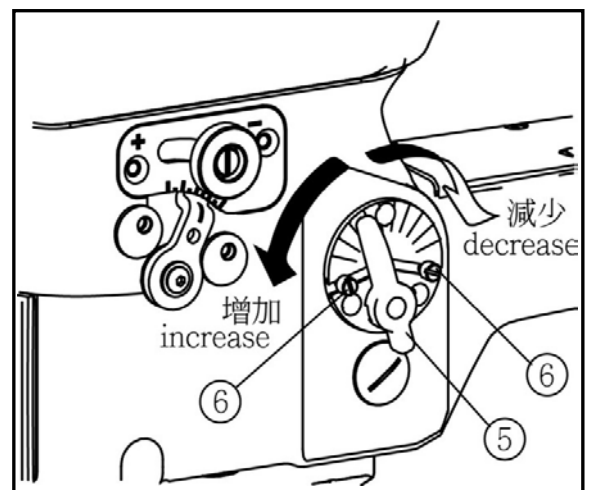

Fig. 29

\* The screw ⑥ is for fixing the position of lever ⑤ and helping the differential movement remain unchanged after adjustment is completed.

\* 螺絲 ⑥ 是用來固定調整桿⑤和保持差動的多或少。

## WARNING

Before adjusting, ALWAYS turn OFF the power switch and check that the motor has stopped.

## 注意

在調整機器之前，一定要先把電源關掉還有確定馬達完全停止。

## 5.8 Adjusting stitch length

### 5.8 調整針距

The standard of stitch length ranges 1.6 - 2.5 mm and can still be adjustable.

粗細針的範圍1.6-2.5mm是標準但  
但可以調整至更大。

#### Adjusting : (Fig. 30)

(1) Loosen the screw ① to adjust the stitch length.

● To increase stitch length, move the screw ① in the direction to "+".

● To decrease stitch length, move the screw ① in the direction to "-".

(2) Tighten the screw ① securely.

#### 調整：(圖30)

(1) 放鬆螺母 ① 去調整粗細針。

● 增加針距時將螺母 ① 往 "+" 方向調整。

● 減少針距時將螺母 ① 往 "-" 方向調整。

(2) 調完成後鎖緊螺母 ①。

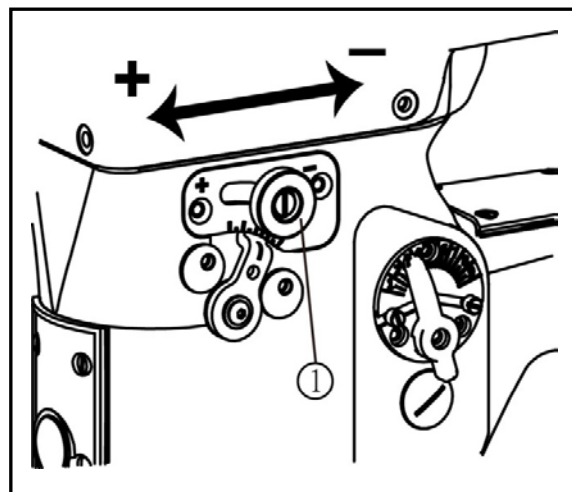

Fig. 30

Table 4 indicates the number of stitches per inch (25.4mm), or per 30 mm.

圖表4 針距大小使用1英吋表示說每英吋或每30mm的距離有幾針。

Stitch length (mm) 針距	Number of stitch (per 1 inch) (25.4mm) 針數	Number of stitch (per 30 mm) 針數
2.5	10	12
2.1	12	14
1.8	14	16.5
1.6	16	19
1.2	21	25
1	25	30

Table 4

#### Adjustment advice

Always adjust stitch length after changing differential feed dog.

#### 調整建議

在每次更換差動狗齒之後要調整粗細針。

## 5.9 Adjusting lapped width of upper fabric

### 5.9 調整切布刀

The standard position of the lower knife ① is to keep a distance between the tip of lower knife ① and the edge of lower knife clamp ② at 0 - 0.5 mm. (Fig. 31)

底刀 ① 的標準位置是要在底刀 ① 尖端和鎖底刀座 ② 之間留 0-0.5 mm 之間隙。(圖31)

The standard position of the upper knife ③ is to overlap between the upper knife ③ and lower knife ① by 0.5 mm when the upper knife ③ is at the extreme left. (Fig. 32)

上刀的轉接位置當上刀 ③ 在最左邊時，上刀 ③ 和底刀 ① 要有 0.5 mm 的重疊。(圖32)

In order to move the fabric edge right or left, fix the position of the lower knife ①, and move the upper knife to overlap lower knife to keep a gap at 0.5 mm in between.

Loosen the screws ④ and ⑤ to adjust the lower and upper knives respectively. (Fig. 32 & 33)

移動刀口到左或右底刀 ① 的位置，然後移動上刀使其跟底刀有 0.5 mm 的間隙。

放鬆螺絲 ④ 和 ⑤ 去調整上刀和底刀。

(圖32 & 33)

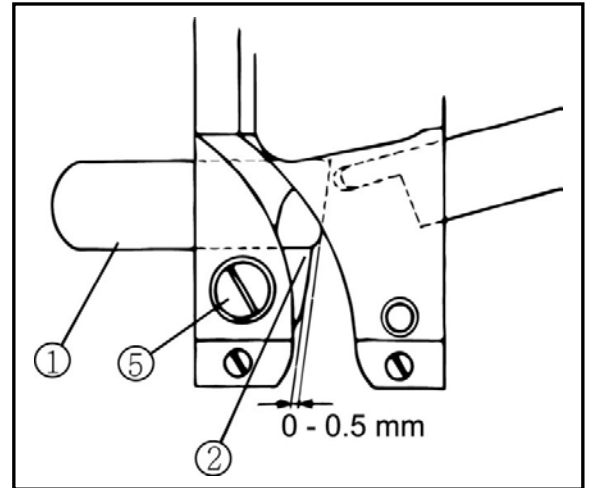

Fig. 31

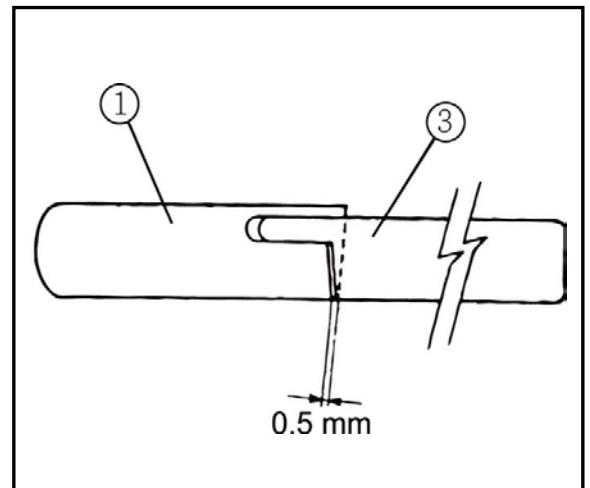

Fig. 32

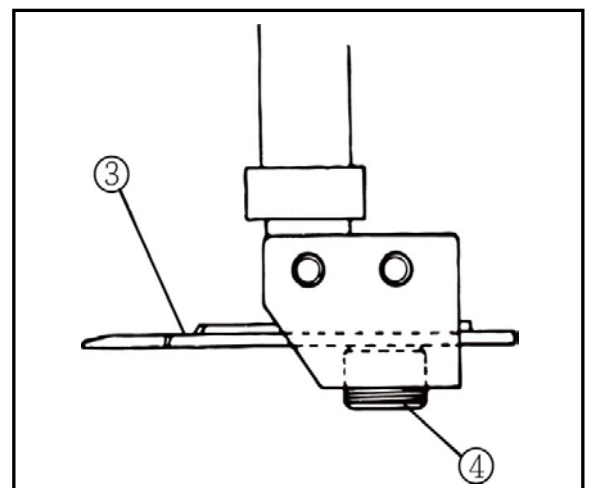

Fig. 33

## 5.10 SP device

### 5.10 過線油組

SP device, for needle thread oiling, is equipped to prevent thread from breaking and stitch from skipping when a machine is running at a high speed or using synthetic thread and/or synthetic fabric.

Fix the felts ①, including accessories, into the SP tank ②. (Fig. 34)

當機器在高速運轉或使用特殊線或特殊纖維時，矽油壺組是標準配備，以防止斷線跳針。當使用機器時，將毛氈 ① 放入矽油壺 ② 內。(圖34)

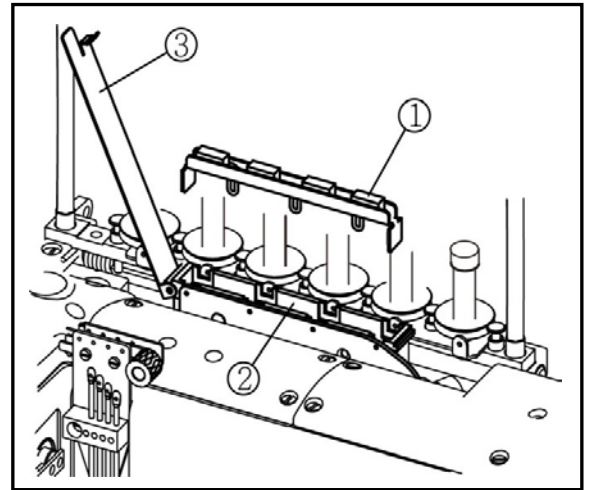

Fig. 34

### CAUTION

1. When SP device is not used, remove the felts ①.  
If not removed, irregular condition may occur during sewing.
2. If the silicone oil is stucked to the parts other than SP device, the parts may be damaged.  
Be sure to wipe silicone oil away.

Use dimethyl silicone oil.

Open the oil cup lid ③ and check the oil amount.

If not enough, supply oil into the SP tank ②. (Fig. 34)

使用乙烷樹脂

打開油壺蓋 ③，檢查油量。如果不夠，添加油於油壺 ②。(圖34)

### 注意

1. 當不使用矽油壺組時，要取出毛氈①。不然可能在車縫時發生不正常情況。
2. 當矽油沾到其他零件時，可能引起機器損傷。故要將油擦乾淨。

## 5.11 Use of lap former

### 5.11 導布器

#### Standard left-and-right position :

Align the point A of the lap former ① with the center point of four needles. (Fig. 36)

#### 調整左右邊的標準位置：

導布器 ① 上的A點要跟4支針的中間成一直線。(圖36)

Depending on lapped edges of the fabrics or fabric feeding, loosen the screws ④ and adjust the position.

鬆開螺絲 ④ 和調整位置視刀的邊緣和刀齒。

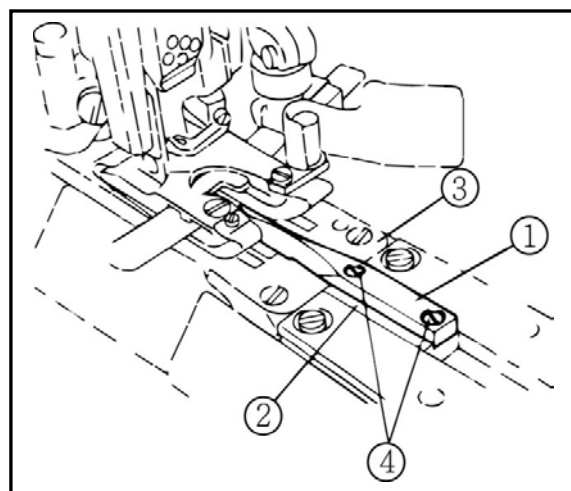

Fig. 35

#### Standard front-and-rear position :

Set the position where the lap former slide block ② touches and stops in the front of the stitch plate ③. (Fig.35)

#### 調整前後的標準位置：

設定滑塊 ② 停止的位置在針板 ③ 前。(圖35)

Depending on fabric thickness, adjust the position of lap former slightly.

視布厚去輕微的調整位置。

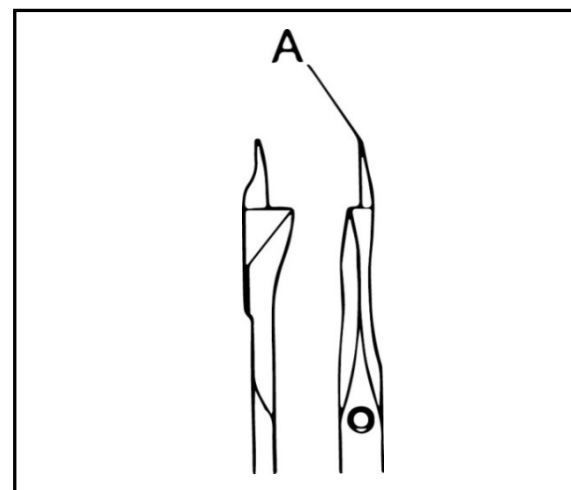

Fig. 36

## WARNING

Before adjusting, ALWAYS turn OFF the power switch and check the motor has already stopped.

## 注意

在調整機器之前，一定要先把電源關掉還有確定馬達完全停止。



## 6.1 Needle thread tension

### 6.1 針線鬆緊

#### Needle thread strike-off pin:

Each of four needles has the needle thread strike-off pin through which the thread tension can be adjusted respectively.

- (1) Set the needle thread take-up ① at the lowest point.
- (2) Set the top of pin ② at the same horizon as the thread of the fourth right needle.
- (3) Set the pin ③ 3.2 mm higher than the pin ②.
- (4) Set the pin ④ 1.6 mm higher than the pin ②.
- (5) Set the pin ⑤ 0.8 mm higher than the pin ②.
- (6) Tighten the screws ⑥ securely.

Note: Check the surfaces of the pin tops are horizontal.

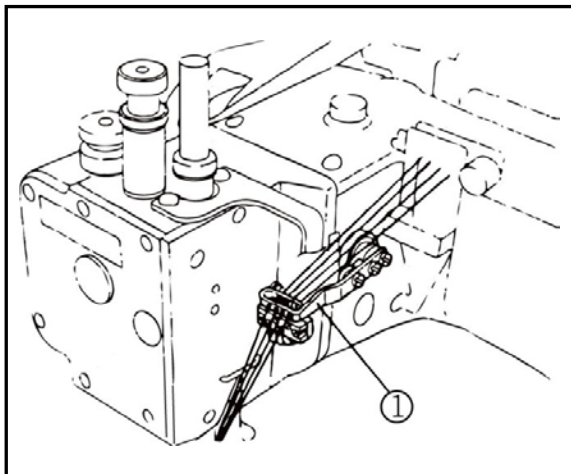

Fig. 37

Loosen the screws ⑥ and move the pins up or down to adjust the needle thread loop.

- To make the loop larger, move the pins in the direction to "L".
- To make the loop smaller, move the pins in the direction to "S".

#### 針線線圈調整片：

4支針各有自己的過線片可以調整線圈的鬆緊。

- (1) 抬線架 ① 轉到最低位置。
- (2) 第一片 ② 要跟右邊第四針的線平齊。
- (3) 設定第四片 ③ 離第一片 ② 的高度為 3.2 mm。
- (4) 設定第三片 ④ 離第一片 ② 的高度為 1.6 mm。
- (5) 設定第二片 ⑤ 離第一片 ② 的高度為 0.8 mm。
- (6) 對準後鎖緊螺絲 ⑥。

註：檢查線片頂端面呈水平。

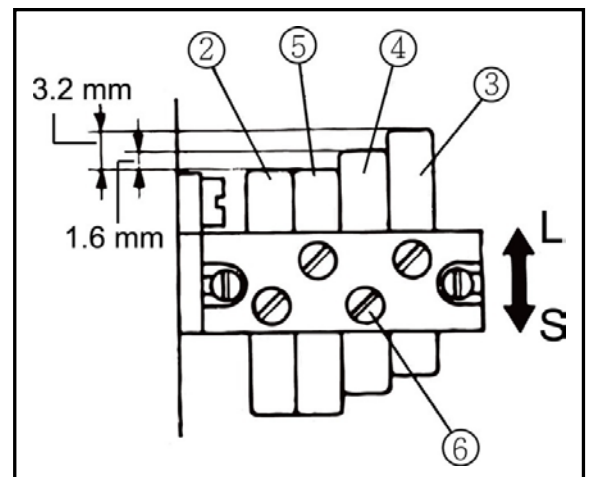

Fig. 38

放鬆螺絲 ⑥ 調整過線片高低然後調整線圈大小。

- 要把線圈變大，需把過線片往"L"上移。
- 要把線圈變小，就把過線片往"S"下移。

**Needle thread eyelet :**

- (1) Make the height of the right needle thread eyelets ① align their eyes with the eyes ③ of the needle thread eyelet holder ②.
- (2) Set the eyelet ④ 5 mm lower than the eyelet ①.
- (3) Set the eyelet ⑤ 9 mm lower than the eyelet ①.
- (4) Set the eyelet ⑥ 15 mm lower than the eyelet ①.

**針線孔：**

- (1) 右邊最高的過線孔 ① 要跟線孔 ③ 成水平直線。
- (2) 設定過線孔 ④ 比 ① 低 5 mm。
- (3) 設定過線孔 ⑤ 比 ① 低 9 mm。
- (4) 設定過線孔 ⑥ 比 ① 低 15 mm。

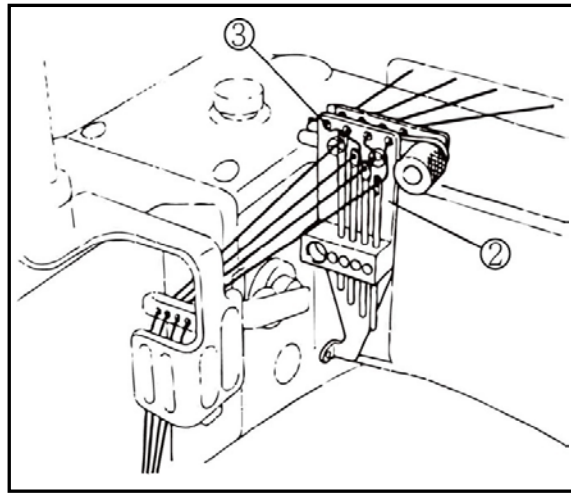

Fig. 39

- Loosen screws ⑦ to adjust the needle thread tension.  
Move eyelets down or up to tighten or loosen threads.
- To tighten needle thread, move the eyelets in the direction of "T".
  - To loosen needle thread, move the eyelets in the direction of "L".

- 放鬆螺絲 ⑦ 可調線鬆緊。  
藉由調整過線片之高低來調整線鬆緊。
- 過線片往 "T" 下移，線就會變緊。
  - 過線片往 "L" 上移，線就會變鬆。

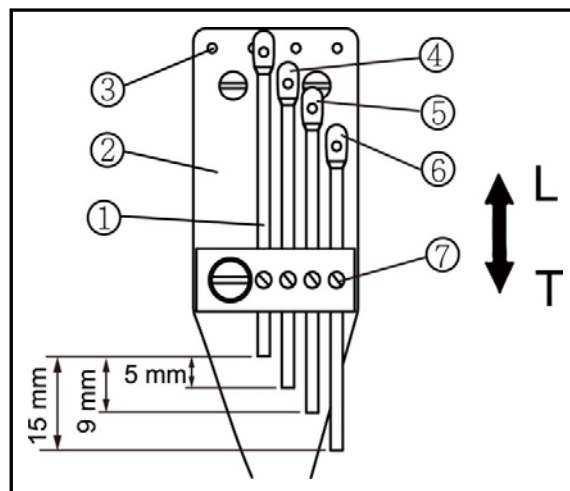

Fig. 40

## 6.2 Looper thread tension

### 6.2 下底線

Check Fig. 41 to see Top looper thread take-up  
調整底線鬆緊請看圖41。

#### Position of looper thread take-up guide :

Align the right side of the looper thread take-up guide  
① with the eyelet supporting plate ②.

#### 底線鬆緊位置的指南：

底線導板 ① 和支稱板 ② 要成一直線。

#### Timing of looper thread take-up :

The correct position of the looper thread take-up ④ is  
when the needle bar ③ moves down from the highest  
point by 2.8 mm, looper thread passes point A.  
Loosen the screws ⑤ to adjust it. (Fig. 41 & 42)

#### 底線收緊時機：

正確的凸輪 ④ 位置是當針柱桿 ③ 最高的位置  
下移2.8 mm 時線通過 A 點。放鬆螺絲 ⑤ 去調整。  
(圖41 & 42)

- To increase the looper thread take-up amount, hasten the timing.

- To decrease the looper thread take-up amount, slow down the timing.

- 增加底線的鬆度，把線凸輪調快。

- 減少底線的鬆度，把線凸輪調慢。

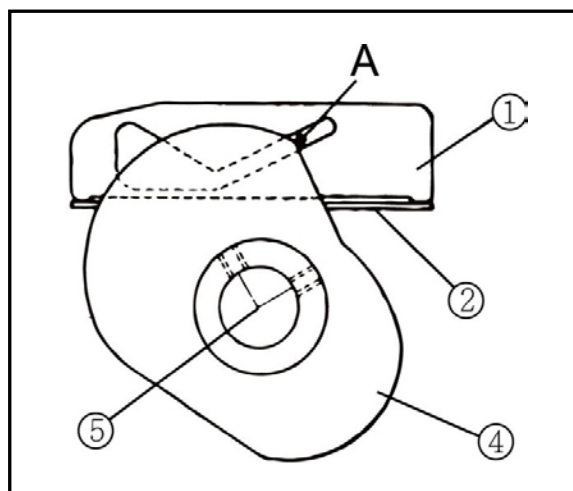

Fig. 41

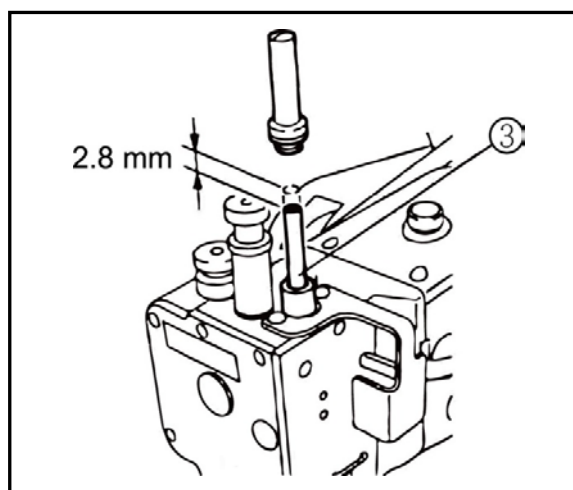

Fig. 42

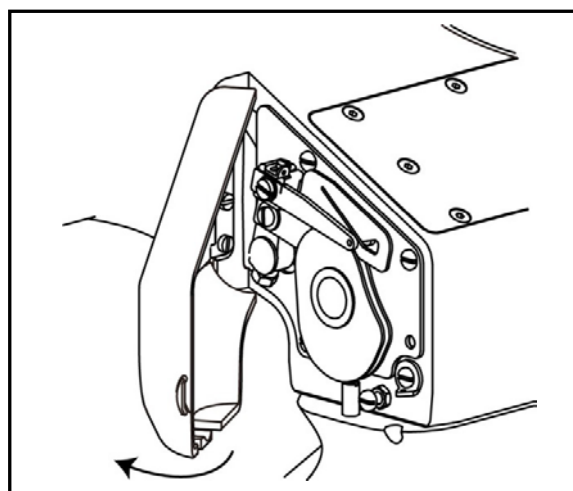

Fig. 43

**CAUTION**

If the timing of the looper thread take-up exceeds the adjustable range, stitch skipping will occur.

**注意**

如果時間差調超過，會造成跳針。

**6.3 Top cover thread tension****6.3 上網線**

Check Fig. 44 to see the top cover thread take-up

調整上網線的鬆緊請看圖44。

- To increase the top cover thread take-up amount, move the eyelet ① upward.
- To decrease the top cover thread take-up amount, move the eyelet ① downward.
- 增加線量時，將過線片 ① 往上移。
- 減少線量時，將過線片 ① 往下移。

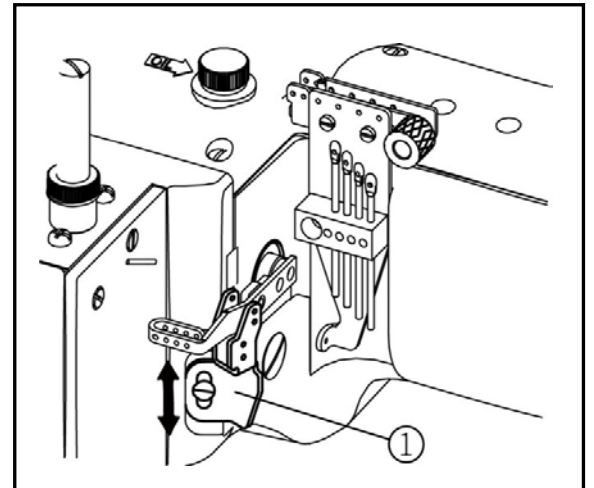

Fig. 44

**WARNING**

Before adjusting, ALWAYS turn OFF the power switch and check the motor has already stopped.

**注意**

在調整機器之前，一定要先把電源關掉還有確定馬達完全停止。

## 6.4 Height of needle

### 6.4 針位高度

Make height "N" of the needle from the surface of the stitch plate to the tip of the fourth needle when the needle is at the highest point.

第一支針跟針板的距離為"N"的高度，但針距大小高度就不同如表所示。

Needle distance	Height(N)
R : 5.2 mm	13.5mm
S : 6.0 mm	12.7 mm

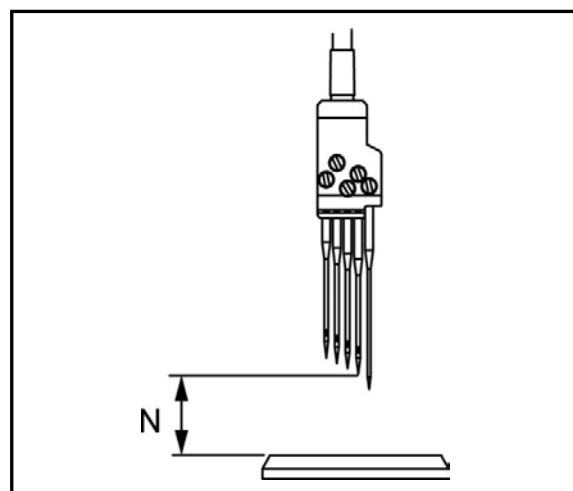

Fig. 45

#### Adjusting height of Needles (Fig. 46) :

- (1) Remove the seal plug ①.
- (2) Loosen the screw ②.
- (3) Move the needle bar ③ up or down to adjust the height.

Check the alignment of Needles (Fig. 47)

- (4) Tighten the screw ② securely.
- (5) Reset the seal plug ①.

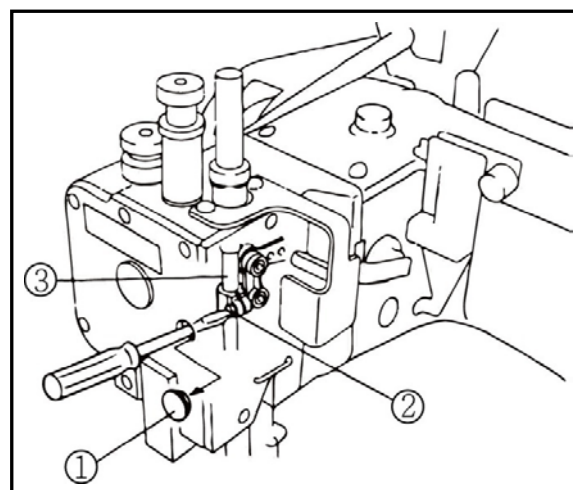

Fig. 46

#### 調整高度(圖46) :

- (1) 移開油塞 ①。
- (2) 鬆開螺絲 ②。
- (3) 上下移動針柱 ③ 去調整度。

檢查調整如圖47

- (4) 鎖緊螺絲重新裝上油塞螺絲 ②。
- (5) 裝回油塞 ①。

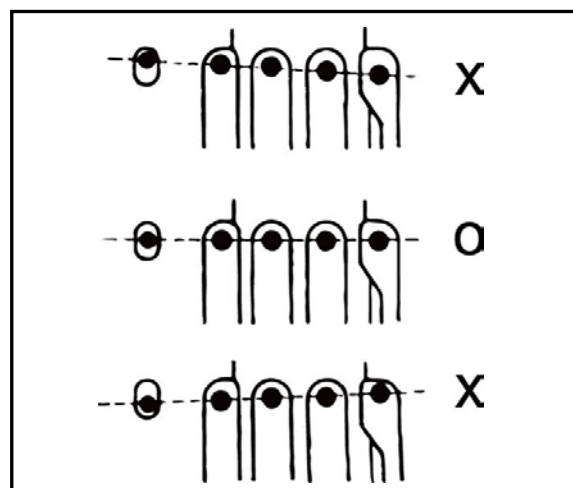

Fig. 47

**WARNING**

Before adjusting, ALWAYS turn OFF the power switch and check the motor has already stopped.

**注意**

在調整機器之前，一定要先把電源關掉還有確定馬達完全停止。

**6.5 Looper****6.5 下勾針****Height :**

Insert the looper ① into the inmost position of the hole of the looper holder ⑥ and tighten the screw ② securely.

**高度：**

裝下勾針 ① 到下勾針座上 ⑥ 然後鎖緊螺絲 ②。

**Angle :**

Fix the flat surface A of the looper at 90° to the looper rocker shaft ③.

Loosen the screw ② to adjust it. (Fig. 48)

**角度：**

下勾針固定座平面 A 要和下勾針柱 ③ 成90度。  
放鬆螺絲 ② 去調整下勾針。(圖48)

**Distance between looper and needle :**

Keep a standard distance 4.2 - 4.8 mm between the looper tip and the center of the left needle when the looper ① is at the extremest left.

Loosen the screw ④ to adjust it.

**下勾針和針的距離：**

當下勾針在最左邊的時後，下勾針 ① 和針的標準距離 4.2 -4.8 mm。

放鬆螺絲 ④ 去調整。

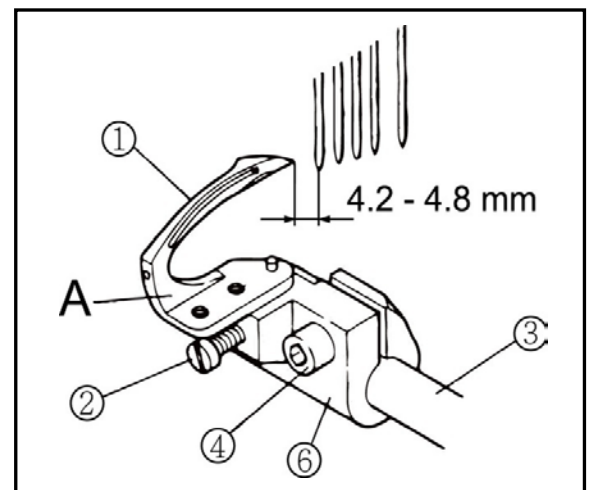

Fig. 48

**Front-and-rear position of looper and needle:**

When the looper ① moves from the left to the right, it passes behind the needle.

Adjust the position to make the looper come close to the needle with the clearance of 0 mm but without touching when the looper tip comes at the center of the left needle.

Loosen the screw ④ and turn the adjusting screw ⑤ to adjust it.

- To move forward, turn the screw ⑤ clockwise.
- To move backward, turn the screw ⑤ counterclockwise. After adjusting, check the distance and tighten the screw ④ securely.

**下勾針的前後位置：**

當下勾針 ① 移動從左到右會在針的後面。調整其位置使下勾針更接近針間隙 0 mm，但不能碰到針，當下勾針的尖端在左針的中間時，放鬆螺絲 ④ 轉動螺絲 ⑤ 調整前後位置。

- 順時間旋轉螺絲 ⑤ 會往前。
  - 逆時間旋轉螺絲 ⑤ 會往後。
- 調整之後檢查間隙和鎖緊螺絲 ④。

When Looper ① moves to the right side to the 4<sup>th</sup> Needle, the bottom edge of the Looper will align with the upper edge of the 4<sup>th</sup> Needle hole. At this moment, make sure the Looper tip passes over the 4<sup>th</sup> Needle by 0.5~0.8mm.

當勾針 ① 往右移動至第四根針時，當勾針下沿對齊針孔上沿時，勾針尖露出第四針 0.5~0.8mm。

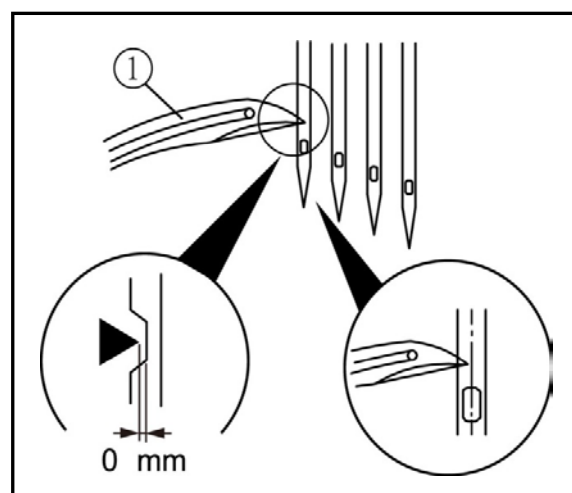

Fig. 49

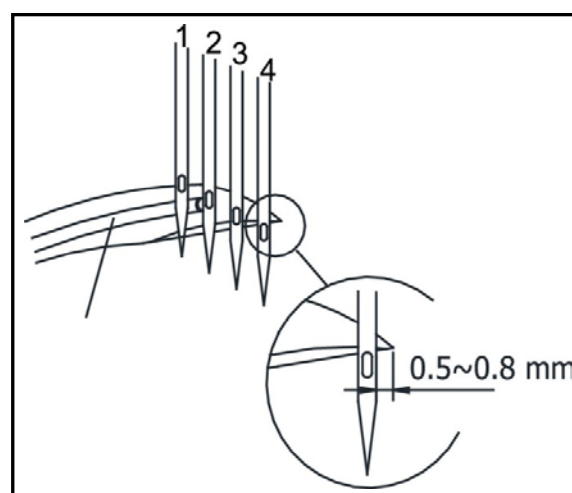

Fig. 50

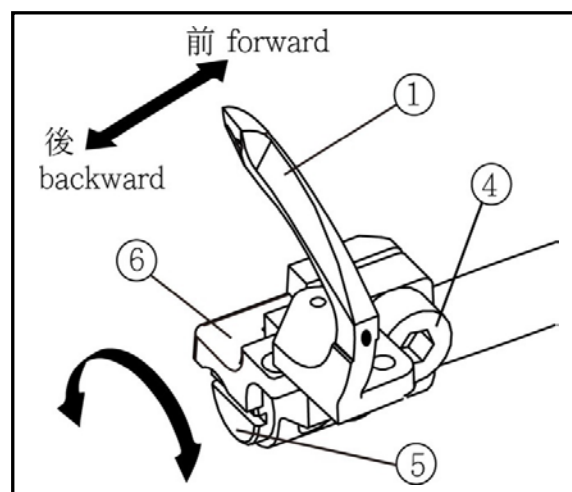

Fig. 51



## 6.6 Needle guard (front)

### 6.6 前針檔

Push the needle guard (front) ① so that the clearance between the needle and the needle guard (front) is 0 mm when the looper tip comes at the center of the left needle.

Loosen the screw ② to adjust it.

Check the looper tip touches the back of the needle and does not swing to the right when the looper ③ moves from the left to the right while rotating the handwheel.

當針在左針中間時推前針檔 ①，使針和前針檔的間隙為 0 mm。放鬆螺絲 ② 去調整它。

當下勾針左移到右時，檢查下勾針 ③ 有無碰到針的後面，看針有無向右移動。

When Looper ③ moves to the center of right needle (4), front needle guard ① pushes needles forward to keep a clearance 0- 0.05 mm from looper. Front needle guard height should be lower by 0.8 ~1mm than needle tip.

Loosen screw ④ to adjust it. (Fig. 52 & 53)

當針移到右針(4號)中間時，前針檔 ① 將針往前推至與勾針間隙為 0- 0.05 mm。前檔針高度應低於針尖 0.8 - 1 mm。

放鬆螺絲 ④ 去調整它。

(圖52 & 53)

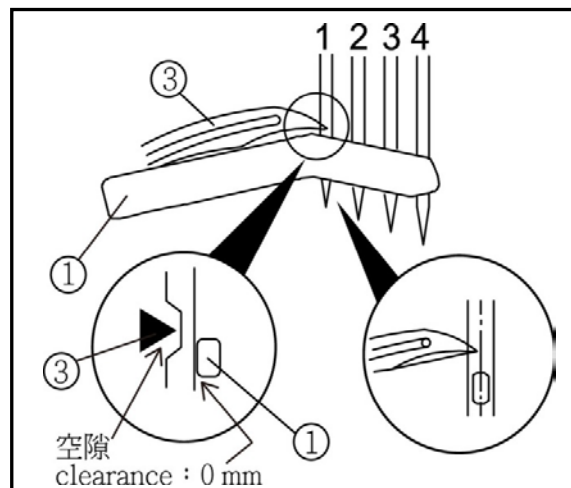

Fig. 52

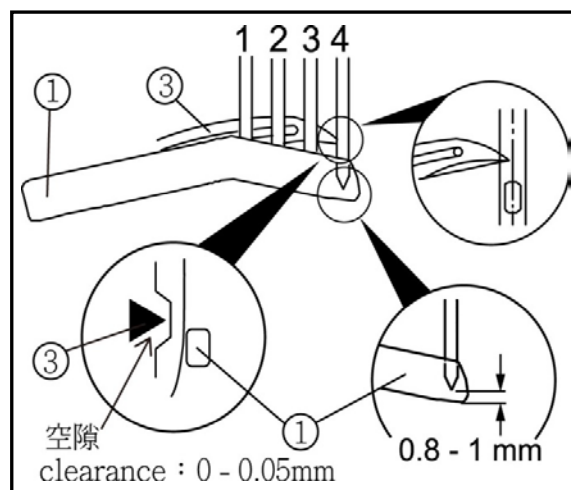

Fig. 53

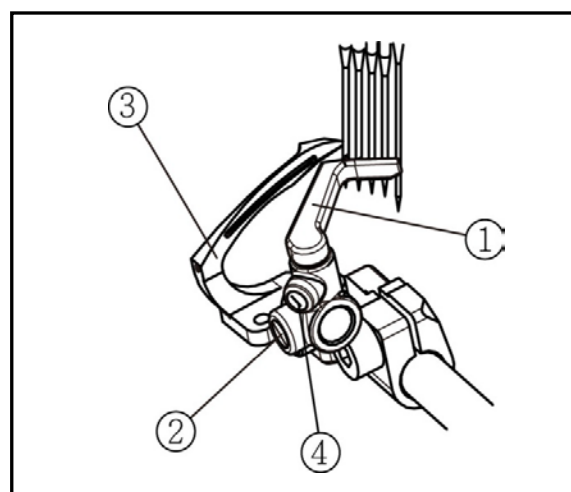

Fig. 54



## 6.7 Needle guard (rear)

### 6.7 後針檔

Make the standard clearance between the needle guard (rear) ④ and the left needle to 0.05 - 0.1 mm when they meet most closely.

Open the looper cover and loosen the screw ⑤ to adjust it. Check the needle does not swing to the right when the looper moves from the left to the right while rotating the handwheel. (Fig.55)

當後針檔 ④ 和針最靠近的時候要有 0.05-0.1 mm 的間隙。放鬆螺絲 ⑤ 去調整。

當下勾針從左移到右時，後針檔不能碰到針。  
(圖55)

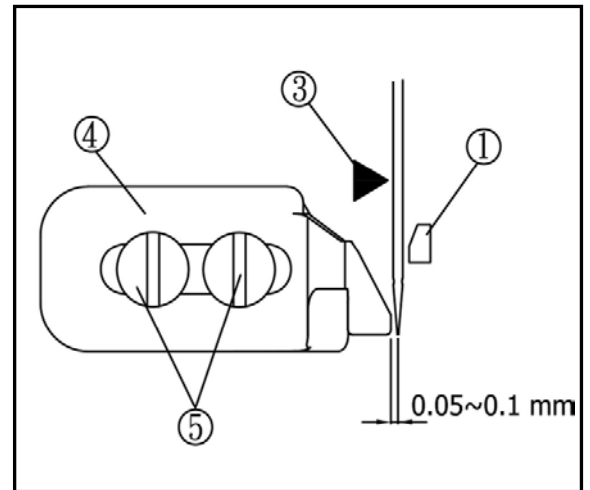

Fig. 55

### Height adjustment of Rear Needle Guard

Stitch width 5.2 mm : (Fig.56)

A Line mark should align with the hole center of the 3<sup>th</sup> Needle.

Stitch width 6.0 mm : (Fig.57)

Line mark should align with the hole center of the 2<sup>th</sup> Needle.

### 護針片高度調整位置

針寬 5.2 mm : (圖56)

針桿在最下死點時，護針片上的 A 線，剛好對準 3號針洞中間。

針寬 6.0 mm : (圖57)

針桿在最下死點時，護針片上的 A 線，剛好對準 2號針洞中間。

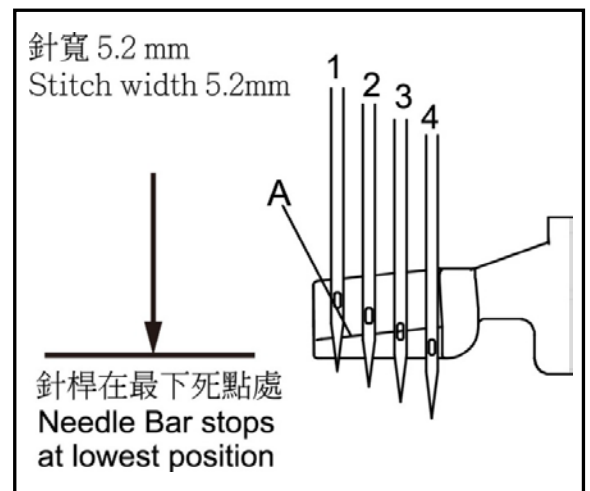

Fig. 56

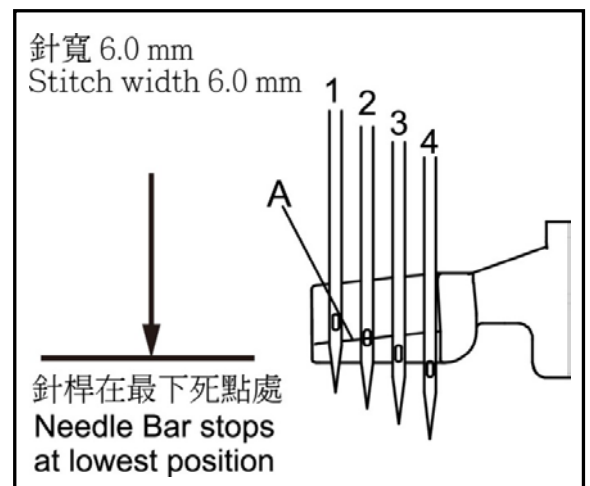

Fig. 57

## 6.8 Top cover thread carrier and hook

### 6.8 上勾針

#### Top cover thread carrier :

Position the top cover thread carrier ① so that top cover thread loop is formed with the hook behind the first and the second needles from the left when the carrier ① comes most nearly to the needle.

Loosen the screw ④ to adjust it.

#### 上網線的時間點：

調整上勾針的位置形成線圈，使第一針和第二針插入線圈內，放鬆螺絲 ④ 調整上勾針 ①。

#### Top cover thread hook :

When the top cover thread hook ② comes most nearly to the top cover thread carrier ③, make the clearance between them to 0.4 -0.7 mm during one rotation.

When the hook ② moves at the extremest right, make the clearance between the hook ② and the retainer ③ to 0.5mm . Loosen the screw ⑤ to adjust them.

#### 上勾針(大)：

當(大)上勾針 ② 和小上勾針 ① 最接近時的間隙為0.4 -0.7 mm。

當(大)上勾針 ② 停在最右邊的時後，和假針 ③ 要有0.5 mm 的間隙。

放鬆螺絲 ⑤ 去調整。

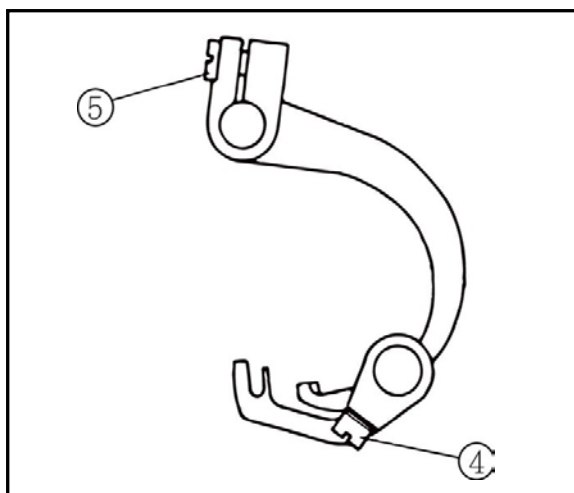

Fig. 61

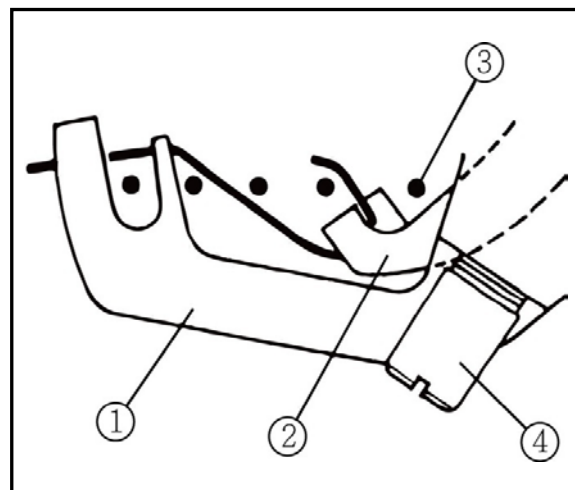

Fig. 58

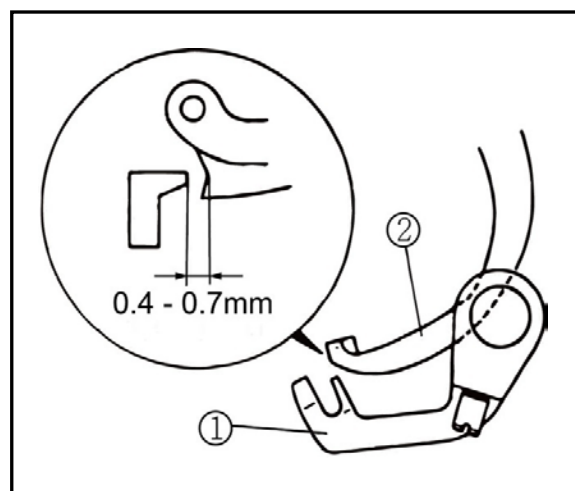

Fig. 59

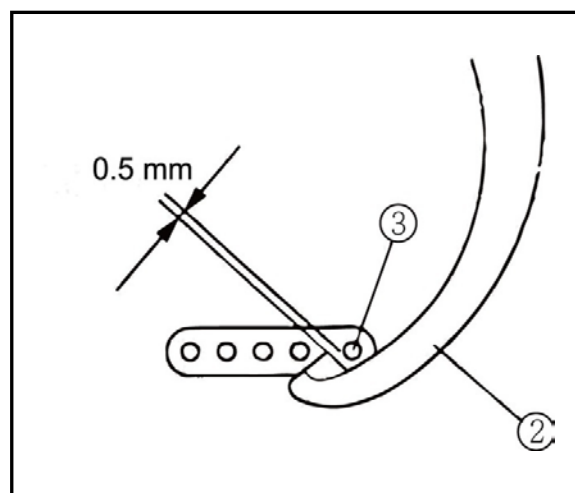

Fig. 60

Note : Be sure not to lift presser foot up and down during adjusting.

註：要調整時，不要上下抬壓腳。

**CAUTION**

When stitch length is changed, the needle guard (rear) ③ needs to be readjusted.

**注意**

當有調整針距時，注意後針檔 ③ 要重新調整。

**6.9 Height of feed dog****6.9 勾齒高度****Fixing :**

Fix the differential feed dog ① and main feed dog ③ with the screws ② and ④ respectively.

**安裝：**

固定差動齒 ① 和主齒 ③ 用螺絲 ② 和 ④ 固定。

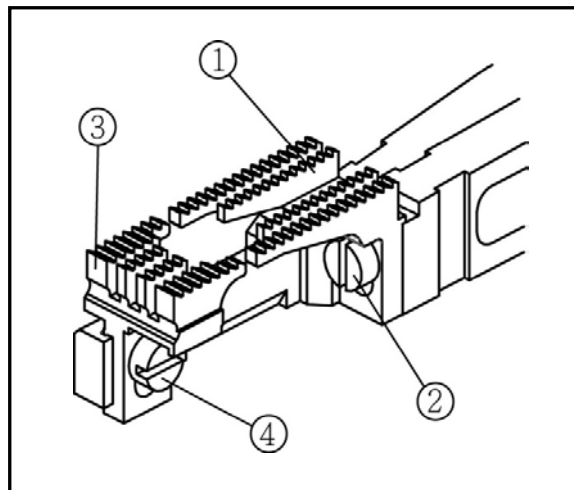

Fig. 62

**Height :**

Adjust the height from the top of the stitch plate to the point A of the main feed dog ③ to 1.2-1.5 mm when the feed dog is at the highest point.

Align the differential feed dog even with the main feed dog.

**高度：**

當勾齒在最高點 - A點，主勾齒 ③ 和針板的高度為1.2-1.5 mm。

前後勾齒必須保持一樣的高度。

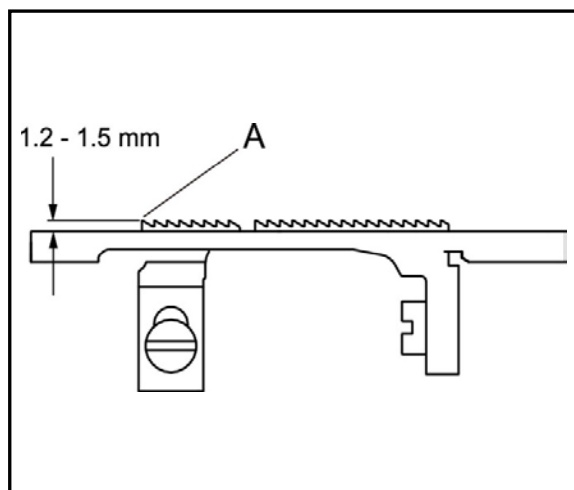

Fig. 63

**Fine adjustment of height :**

Make fine adjustment of height of the main and differential feed dogs with the eccentric pin ⑧ near the center of the cylinder.

Loosen the screw ⑦ and move the pin ⑧ to adjust it.

- To lower the feed dog, turn the pin ⑧ clockwise.
- To raise the feed dog, turn the pin ⑧ counterclockwise.

**高度微調：**

勾齒的高度微調要旋轉偏心銷 ⑧ 來控制。  
放鬆螺絲 ⑦ 然後調整偏心銷 ⑧ 的高低。

- 順時針旋轉偏心銷 ⑧ 降低勾齒。
- 逆時針旋轉偏心銷 ⑧ 調高勾齒。

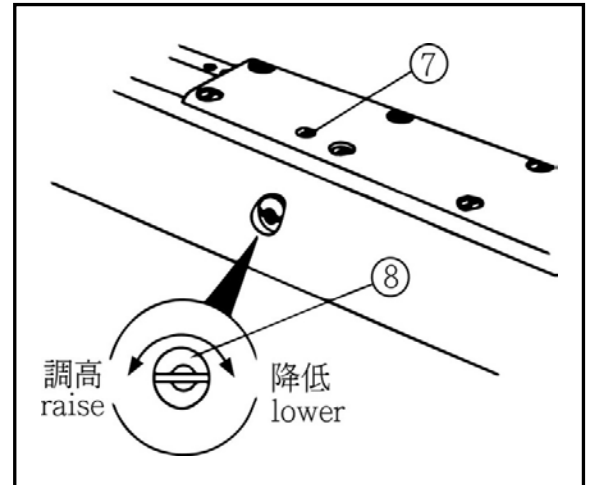

Fig. 64

**Advice on adjustment**

Set the groove of the eccentric pin ⑧ horizontally and loose the screw ⑦ before fixing the height of main and differential feed dogs

**調整建議：**

裝上前後狗齒前先調整偏心銷 ⑧ 成水平，鬆開螺絲 ⑦ 才能同時移動前後狗齒的高低。

**Easy to use**

When only removing the stitch plate, turn the eccentric pin ⑧ to the left to lower the feed dogs.

**簡易方法：**

要拆掉針板時，先把偏心銷 ⑧ 向左旋轉一點，使前後狗齒同時調低，好讓針板容易拆下。

## 6.10 Replacing presser foot

### 6.10 置換壓腳

#### Removing :

- (1) Remove all needles and the seal plug ①.
- (2) Loosen the adjusting screw ② and then the screw ③ of the presser bar connecting bracket.
- (3) Loosen the screw ④ of the knife holder guide collar to be free the complete set including the upper knife, the knife holder, and the knife holder shank.
- (4) Loosen two screws ⑦ of the knife holder bracket ⑥ to remove the knife holder guide collar, c. set ⑤ and the upper knife.
- (5) Loosen the screw ⑧ on the back of the presser foot.
- (6) Rotate the handwheel to raise the needle at the highest point. Remove the adjusting screw ② and keep the presser bar ⑨ and the presser spring ⑩ upward as they come off from the presser foot.
- (7) Remove the carrier/hook driving segment ⑪ from the lever ⑫ on the carrier/hook driving sleeve.
- (8) Turn the presser foot, c. set to the left and remove it through the presser foot guides(left) and (right) backward.

#### 調動方法：

- (1) 移開所有的針和油塞 ①。
- (2) 放鬆調整螺帽 ② 然後才鬆開螺絲 ③。
- (3) 鬆開刀台的螺絲 ④ 讓整組刀架鬆開。
- (4) 鬆開刀座連桿 ⑥ 的兩顆螺絲 ⑦ 去移除上刀座 ⑤ 和上刀。
- (5) 放鬆壓腳螺絲 ⑧，鬆開螺絲 ⑭ 移除檔柱 ⑬。
- (6) 將針轉到最高點然後移除調整螺帽 ② 和抽出壓腳柱 ⑨ 和壓腳彈簧 ⑩ 向上出來。
- (7) 推開上勾針馬達驅動片 ⑪ 從帶動桿 ⑫ 脫離。
- (8) 向左轉拆下整組壓腳穿過左邊壓腳檔。

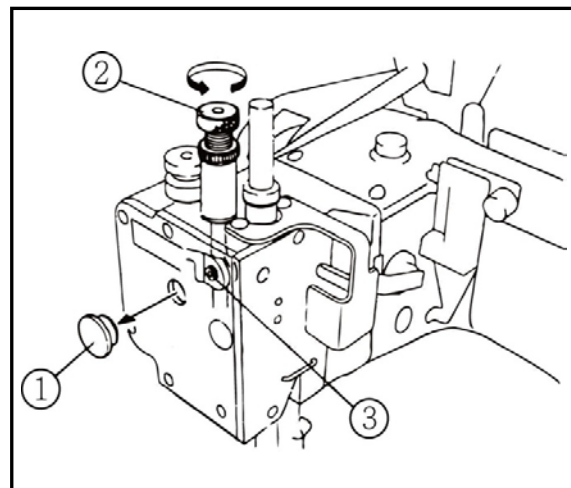

Fig. 65

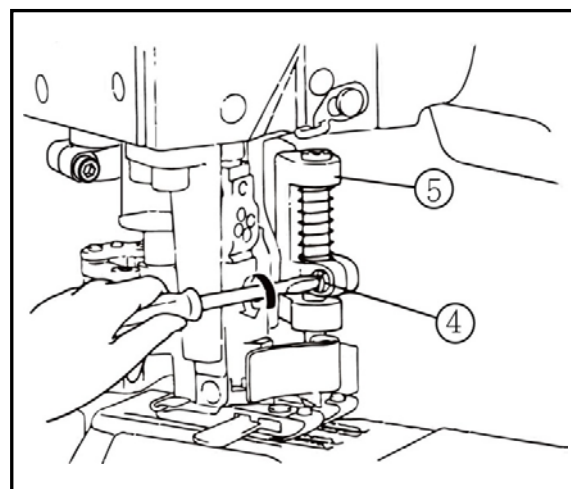

Fig. 66

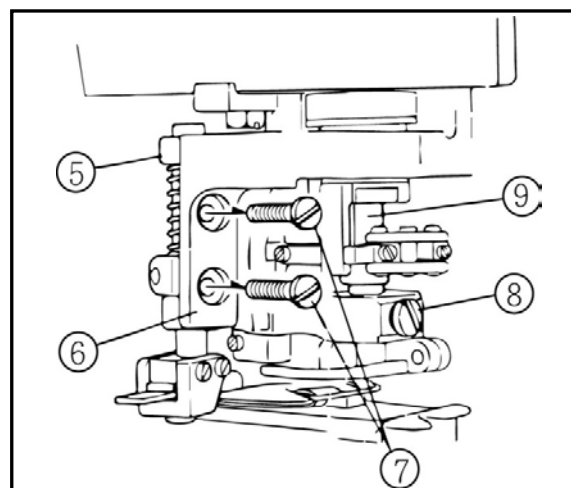

Fig. 67

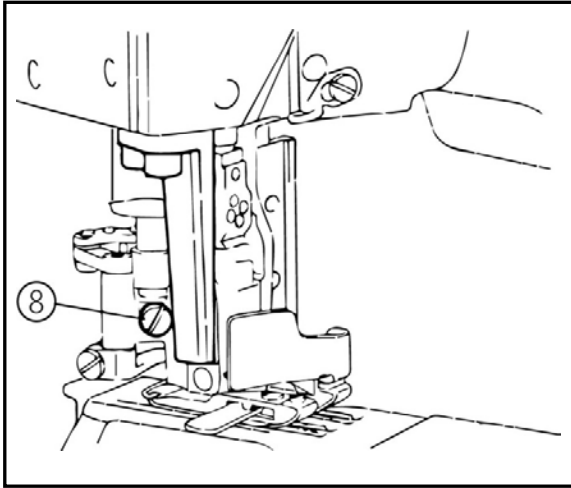

Fig. 68

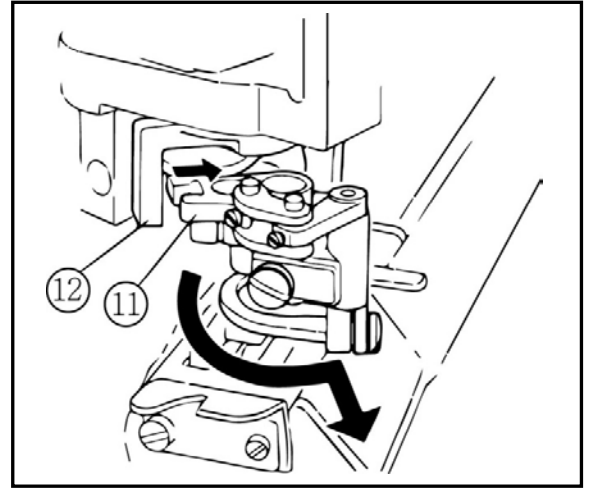

Fig. 71

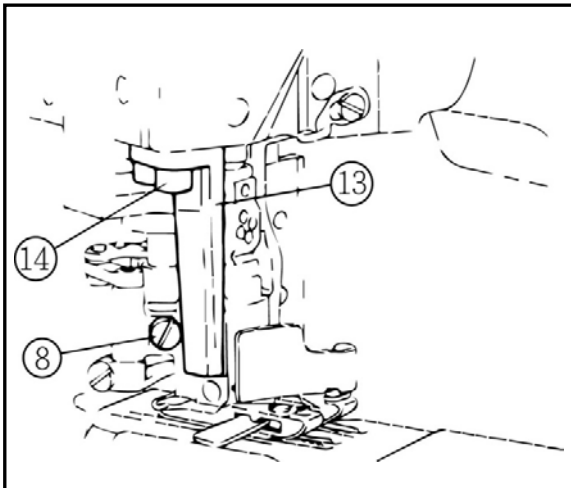

Fig. 69

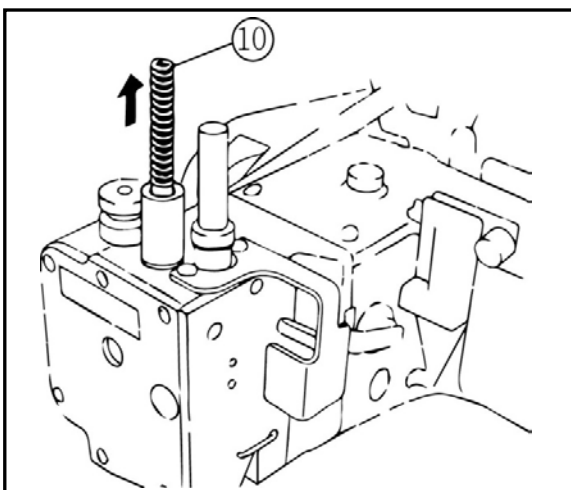

Fig. 70

## WARNING

Before adjusting, ALWAYS turn the motor switch OFF and check that the motor has already stopped.

## 注意

在調整機器之前，一定要先把電源關掉還有確定馬達完全停止。

**Resetting :**

Refer to Figs. 65-71 for resetting.

- (1) Remove all needles. Reset the presser foot, c. set between the presser foot guides(left) and (right) while turning it to the right diagonally from the back.
- (2) Reset the carrier/hook driving segment ⑪ on the lever ⑫ on the carrier/hook driving sleeve.
- (3) Insert the presser bar into the carrier/hook driving segment ⑪ and tighten the screw ⑧ on the back of the presser foot.
- (4) Check the presser foot moves smoothly without play right and left. If not, loosen the screw ⑭ of the presser foot guide(left) ⑬ to adjust it.
- (5) Reset the knife holder guide collar, c. set ⑤ and the upper knife on the knife holder bracket ⑥ with two screws.
- (6) Adjust the positions of the knife holder guide collar and the upper knife when the needle is at the lowest point. (See "6.12 Replacing and adjusting knives" )
- (7) Reset the adjusting screw ② when the needle is at the lowest point and the presser foot touches closely on the stitch plate. Then tighten the screw ③ of the presser bar connecting bracket while pushing slightly down.
- (8) Reset the seal plug ①.
- (9) Reset all needles.

**重排：**

將圖65-71重新安裝

- (1) 拆掉全部的針重新裝上壓腳在左右壓腳檔之間，向右旋轉，放正壓腳。
- (2) 重新裝上上勾針驅動片 ⑪ 到帶動桿 ⑫ 裡面。
- (3) 安裝壓腳柱插入上勾針驅動片 ⑪ 後鎖上壓腳後面的螺絲 ⑧。
- (4) 檢查壓腳是否順暢沒有左右晃動，如果有卡住，鬆開左壓腳檔 ⑬ 的螺絲 ⑭ 去調整。
- (5) 重新裝上刀台 ⑤ 固定在刀座 ⑥ 支撐架上。
- (6) 調整刀台和上刀的位置，當針在最低點的時候。(參考"6.12 置換和調整位置")
- (7) 當壓腳緊貼在針板上和針在最低點時重新裝上調整螺帽 ② 然後輕微的壓下螺絲 ③ 並鎖上。
- (8) 裝回油塞 ①。
- (9) 裝回所有的針。

**WARNING**

**Before adjusting, ALWAYS turn the motor switch OFF and check that the motor has already stopped.**

**注意**

在調整機器之前，一定要先把電源關掉還有確定馬達完全停止。

## 6.11 Replacing presser foot spring plate

### 6.11 置換壓腳彈簧片

#### Removing :

- (1) Remove the screws ①.
- (2) Remove the presser foot spring plates ② from the presser foot.
- (3) Remove each plate ② from the spring plate holder ③.

#### 調動方法：

- (1) 拆掉螺絲 ①。
- (2) 拆掉壓腳彈片 ②。
- (3) 移開彈簧片勾 ③ 才能拿掉彈簧片 ②。

#### Resetting :

- (1) Reset each presser foot spring plate ② with the spring plate holder ③.
- (2) Reset the plates ② parallel each other on the presser foot ②.
- (3) Tighten the screws ① securely.

#### 重排：

- (1) 重新裝上壓腳彈片 ② 和壓腳彈片勾 ③。
- (2) 每片彈簧片 ② 要對齊壓腳座。
- (3) 鎖上螺絲 ①。

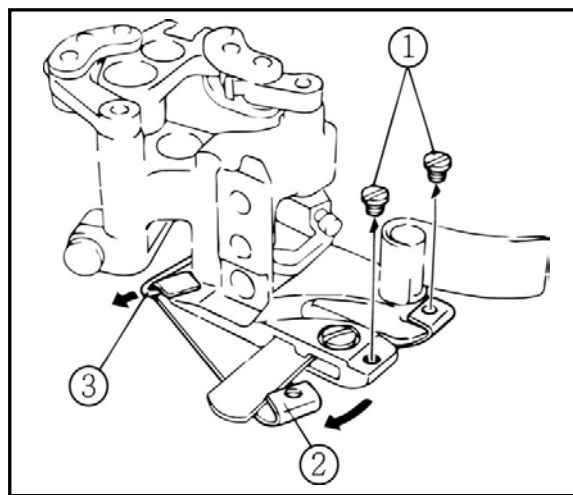

Fig. 72



## 6.12 Replacing and adjusting knives

### 6.12 置換和調整位置

#### Pressure of upper knife :

When the needle is at the highest point and the upper knife ① is at the extreme left, the presser foot touches the stitch plate, and the upper knife ① touches the lower knife ② closely.

The standard clearance between the bearing of the knife holder shank support ③ and the knife holder guide collar ④ is 1.0 mm .

#### 上切刀的壓力：

當針在最高點，上切刀在左邊時壓腳要貼著針板上，上切刀 ① 刀刃要貼合下切刀 ② 的刀刃。  
刀座 ③ 和壓力彈簧軸環 ④ 之間的標準間隙為 1.0mm。

Loosen the screw ⑤ and move the knife holder collar ④ to adjust the pressure.

- To increase the pressure, move the collar ④ upward.
- To decrease the pressure, move the collar ④ downward.

鬆開螺絲 ⑤ 和移動軸環 ④ 調整壓力。

- 增加壓力往上移動彈簧軸環 ④。
- 減少壓力往下移動彈簧軸環 ④。

Note : When the front sides of the upper ① and lower ② knives align each other, the upper knife can not touch presser foot.  
After checking, fix the knife holder guide collar ④.

註：上刀 ① 和下刀 ② 成一直線時，上刀不能碰到壓腳壁。調正確後，固定彈簧軸環 ④。

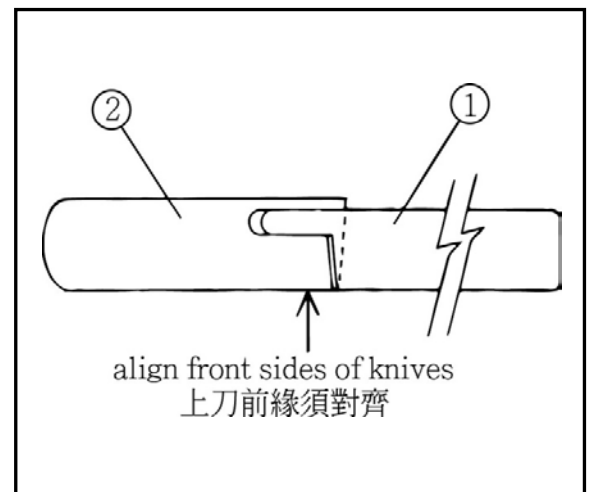

Fig. 73

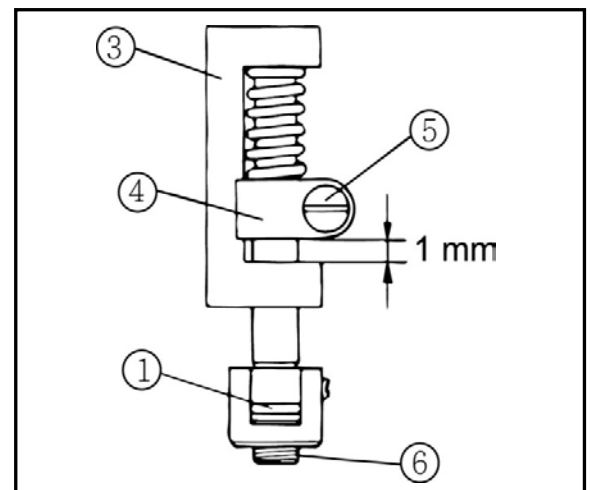

Fig. 74

**Removing :**

- (1) Loosen the screws ⑤ and ⑥ to remove the upper knife ①.
- (2) Loosen the screw ⑦ to remove the lower knife ②.

**調動方法：**

- (1) 放鬆螺絲 ⑤ 和 ⑥ 才能拆掉上切刀 ①。
- (2) 放鬆螺絲 ⑦ 才能拆掉下切刀 ②。

**Resetting :**

- (1) Reset the lower knife ② with the screw ⑦.
- (2) Reset the upper knife ① with the screw ⑥.  
See "5.9 Adjusting lapped width of upper fabric" for engagement of the knives.
- (3) Adjust the knife holder guide collar ④, referring to above "Pressure of upper knife".

**重排：**

- (1) 重新安裝下切刀 ② 要鎖緊螺絲 ⑦。
- (2) 重新安裝上切刀 ① 要鎖緊螺絲 ⑥。安裝方法請看 "5.9 調整切布刀"。
- (3) 調整軸環 ④ 請依前面幾項說明的方法來調整。

**Engaging angle of upper knife to lower knife**

Remove the parts ① - ⑤ in order and turn the screw ⑥ to adjust it.

When resetting, check the screw ⑦ is not out from the bottom of the knife support ⑤. Then insert it into the bracket hole ⑧ to tighten.

**上切刀角度之調整**

拆掉 ① - ⑤ 的部份，螺絲 ⑥ 去調整刀的角度。重新安裝時要注意插銷 ⑦ 有無對準刀座 ⑧ 上的孔。

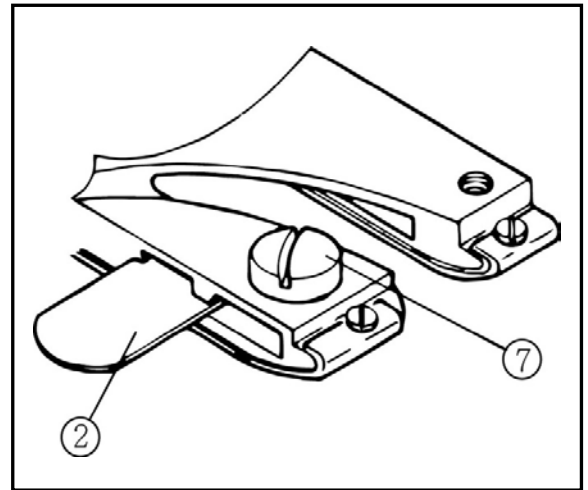

Fig. 75

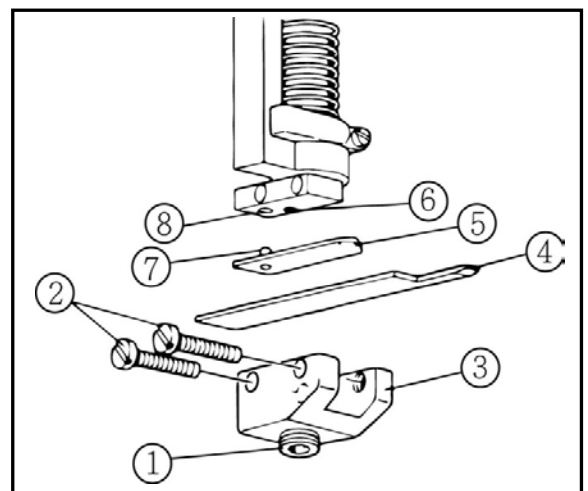

Fig. 76

# 7. Specifications

規格

Description 說明	Four-needle and six-thread feed-off-the-arm model industrial interlock sewing machine 曲臂型四針六線拼縫機
Dimensions 體積	530mm(L) X 270mm(W) X 410mm(H) 530mm(長) X 270mm(寬) X 410mm(高)
Circumference of Cylinder 圓週	148mm at needle drop 針棒下緣最小圓週148 mm
Working Space 工作空間	Cylindrical shape of 210 mm in front of needle drop 圓週210 mm 是本機的操作範圍
Weight 重量	26kg (machine head only) 26公斤 (頭部)
Sewing Speed 車縫速度	RPM (Working) 3500 , RPM (MAX.) 3800 正常工作轉速最快可達：3500rpm，極速3800rpm
Stitch Length 縫距	1.6-2.5 mm. The number of stitches 10-16 stitches per inch(25.4 mm) 12-19 stitches per 30 mm. 16-25 mm。 每英寸10-16針(25.4mm)。每30mm 12-19針。
Needle System 針型	Sewing needle : TNC、Organ FL X 118GCS , Groz-Beckert UY118GKS Retainer needle : TNC、Organ FLG-2 , FLG-1 , FLF-8 (with scarf) Groz-Beckert 36211, 36211A (with scarf) 真針：TNC、Organ FL X 118GCS , Groz-Beckert UY118GKS 假針：TNC、Organ FLG-2 , FLG-1 , FLF-8 (with scarf) Groz-Beckert 36211 , 36211A (with scarf)
Needle Distance 針距	R : 5.2 mm (13/64 inches) S : 6.0 mm (15/64 inches)
Presser Foot Lift 抬壓腳	01 : Max. 8 mm, 02 : Max. 6 mm at the highest point of needle clamp 01 : 最大 8 mm, 02 : 最大 6 mm 最高針位
Feed Regulation 送料方式	By lever 桿槓原理
Differential Ratio 差動比	Max. normal differential : 1.0 : 1.5 Max. reverse differential : 1.0 : 0.7 最大 一般差動比：1.0 : 1.5 最大 反差動比：1.0 : 0.7
Differential Feed Regulation 差動送料規則	By dial 轉盤
Knives of Fabric Cutting 切布刀	Both upper and lower knives made of special steel 上下刀都用特殊鋼製造的

Lubrication 潤滑	Automatically by gear pump 自動齒輪幫浦
Lubricating Oil 潤滑油	SF OIL No.68
Capacity of Oil Reservoir 油槽容量	Frame : about 100 cc      Cylinder : about 100 cc 框：約100 cc      筒：約100 cc
Compliance with Regulation 符合規定	Compliant with the PL Law and the CE Marking 符合 PL 法律與 CE 標誌

  
名匠縫紉機股份有限公司

經銷商：

2021.09