

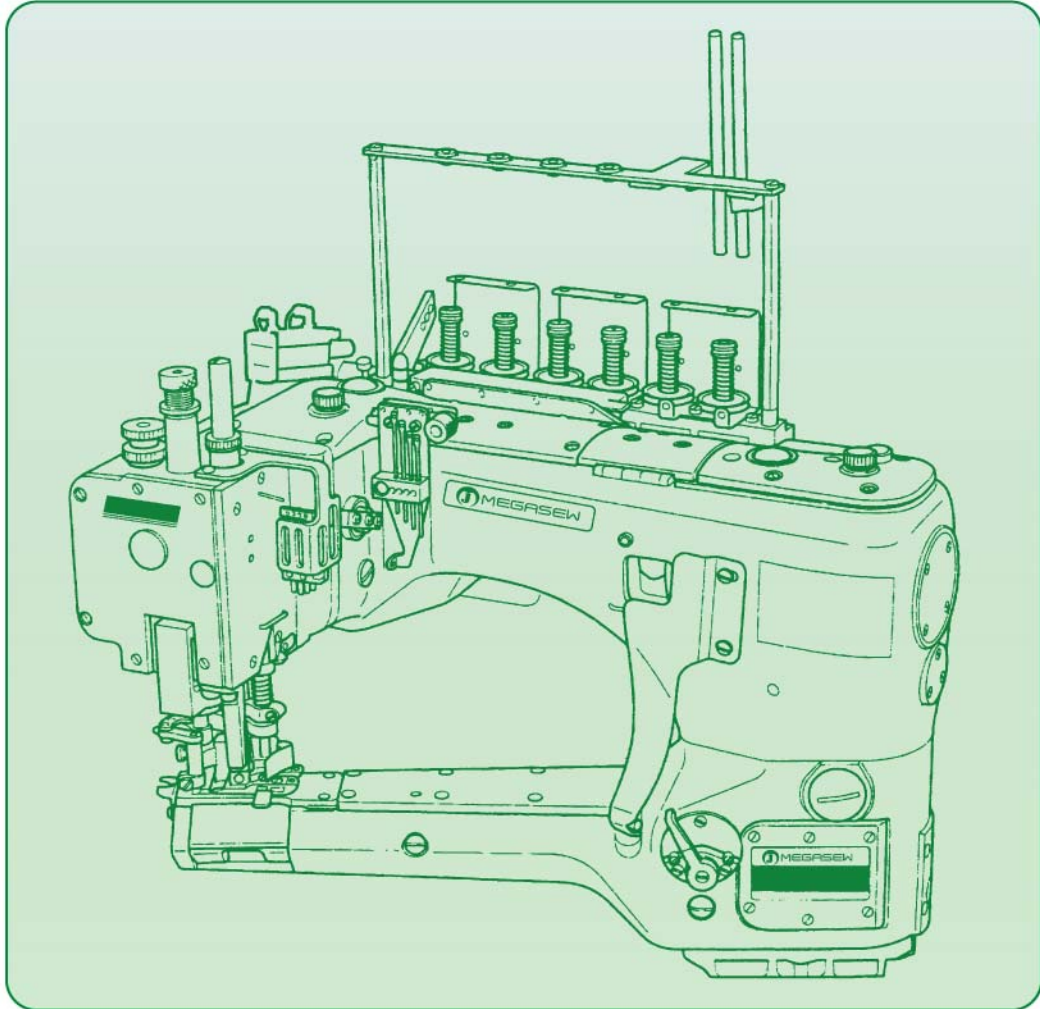

MEGASEW
Industrial sewing machine



MJ62G(GX)&MJ62D(DX)

使用&維修手冊

INSTRUCTION BOOK

名匠縫紉機股份有限公司

MING JANG SEWING MACHINE CO.,LTD.

CONTENTS

Safety introduction

i-iv

1. Name of each part	各部份名稱	1
2. Installation	安裝	2
2.1 Installation	安裝	2
2.1.1 Motor table top type	桌板尺寸	2
2.1.2 Installing machine head	車頭安裝	3
2.2 Adjusting Presser foot lift	調整抬壓腳	4
2.2.1 Presser foot connecting lever	壓腳連接桿	4
2.2.2 Presser foot lift	抬壓腳	5
2.2.3 Tension release unit	過線組	7
2.3 Motor and belt	馬達&皮帶	8
2.4 Hanging belt	皮帶鬆緊	9
2.5 Belt cover	皮帶護蓋	10
2.6 Other parts	其它部份	11
3. Sewing speed and rotating direction of pulley	馬達轉速&皮帶輪轉動方向	12
4. Lubrication	潤滑	13
4.1 Lubricating oil	潤滑油	13
4.2 Lubricating	潤滑系統	13
4.3 Priming oil	啟動注油	14
4.4 Priming	補充油	14
4.5 Changing oil	更換油	16
5. Proper operation	使用說明	17
5.1 Needle system	車針系列	17
5.2 Installing needle	針的安裝	18
5.3 Threading	線	19
5.4 Thread tension	線鬆緊	20
5.5 Pressure of presser foot	調整壓腳壓力	20
5.6 Up-and-down position of presser foot	調整壓腳高低	21
5.7 Adjusting differential feed dog	調整差動	22
5.8 Adjusting stitch length	調整針距	23
5.9 Adjusting lapped width of upper fabric	調整切布刀	25
5.10 Sp device	過線油組	26
5.11 Use of lap former	導布器	27

CONTENTS

6. Adjustments	調節裝置	28
6.1 Needle thread tension	打線組	28
6.2 Looper thread tension	下底線	31
6.3 top cover thread tension	上網線	33
6.4 Height of needle	針位高度	35
6.5 Top cover thread carrier and hook	上撥線架	36
6.6 Looper	下勾針	38
6.7 Needle guard(front)	前針檔	40
6.8 Needle guard(rear)	後針檔	40
6.9 Height of feed dog	勾齒高度	41
6.10 Replacing presser foot	置換壓腳	43
6.11 Replacing presser foot spring plate	置換壓腳彈片	47
6.12 Replacing and adjusting knives	置換和調整位置	48
7. Specifications	規格	51

1. Name of each part

各部份名稱

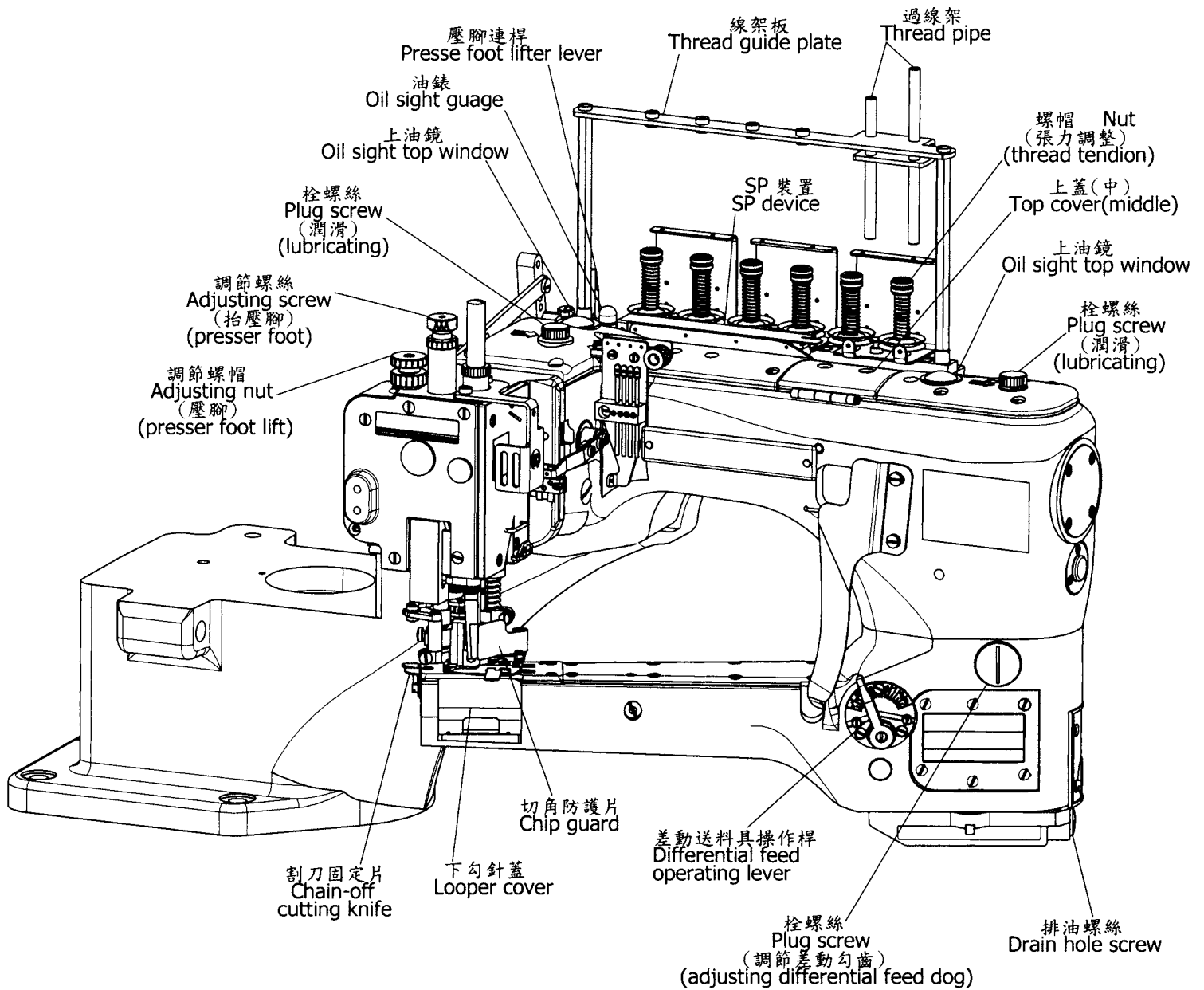

Fig. 1

2.1 Installation

2.1 安裝

2.1.1 Motor table top type

2.1.1 桌板尺寸

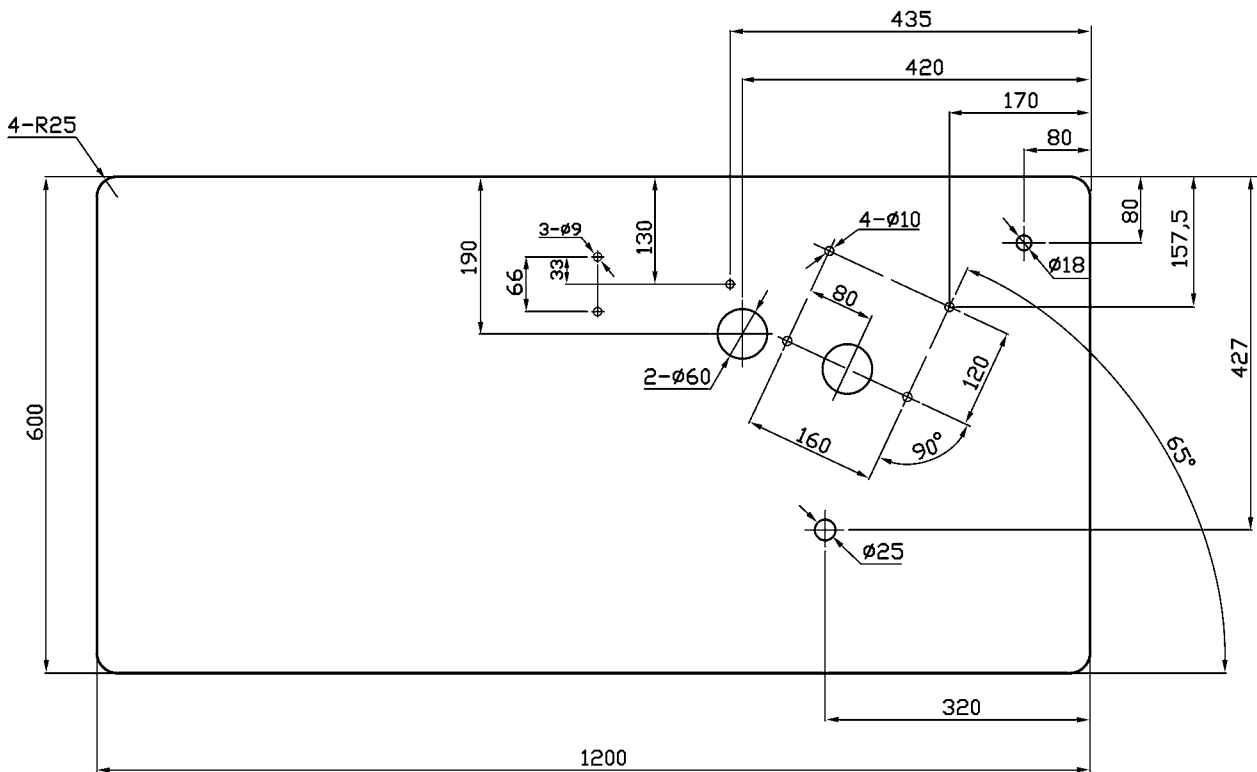

Fig. 2

2.1.2 Installing machine head

2.1.2 車頭安裝

Install a sewing machine on the sewing machine supporting block with two screws. (Fig.3)

組裝縫衣機到支撐塊上面要用2顆螺絲。

WARNING

If the machine is feld down, it can occur injury and machine damage.

Always install the machine with two persons or more.

注意

如果機器翻倒，它會發生損害。避免機器的損壞
安裝機器時必需2人以上。

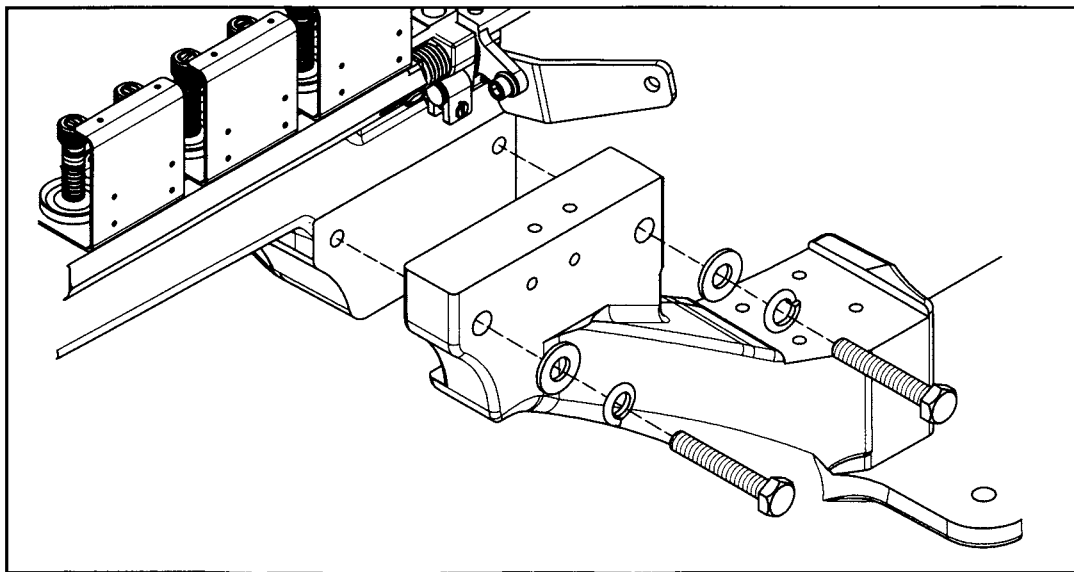

Fig. 3

When using the pedestal, install a sewing machine on the pedestal with two screws. (Fig. 4)

安裝縫紉機時，用2顆螺絲及墊片固定。

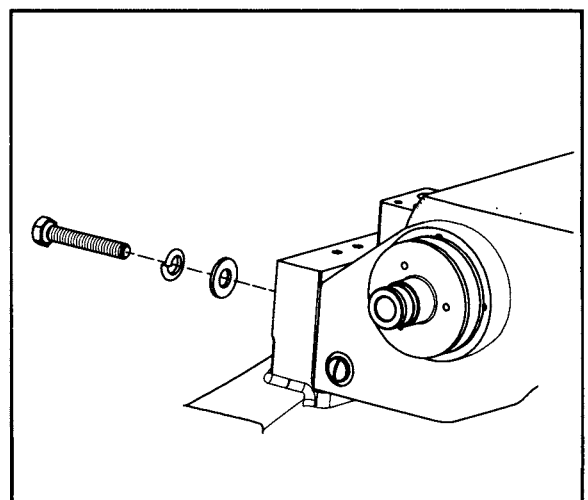

Fig. 4

WARNING

Before operation, unplug the motor's power cord from the outlet.

注意

操作前，請先關閉電源。

2.2 Adjusting presser foot lift

2.2 調整抬壓腳

2.2.1 Presser foot connecting lever

2.2.1 抬壓腳連接桿

Set the persser foot connecting lever ① with the screw ② and the washer ③ . (Fig.5)

設置壓腳連接軸①專用螺絲②和墊片③。

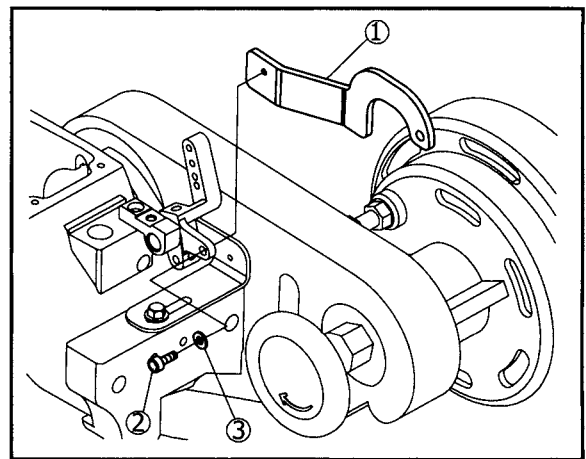

Fig. 5

2.2.2 Presser foot lift

2.2.2 抬壓腳

1. As standard, make the clearance between the presser bar lifter lever ① and the presser bar connecting bracket ② to 1 mm when the presser foot touches the stitch plate closely.(Fig. 6,7)

Note: The clearance between the body of the presser foot and presser foot spring plate has 0.3mm

1. 當壓腳緊貼在針板上時，在抬壓腳連接軸 ① 跟壓腳連接托架 ② 留 1mm 的間隙。(Fig. 6,7)
- 註：壓腳主體跟壓腳彈片之間要有 0.3mm 的間隙。

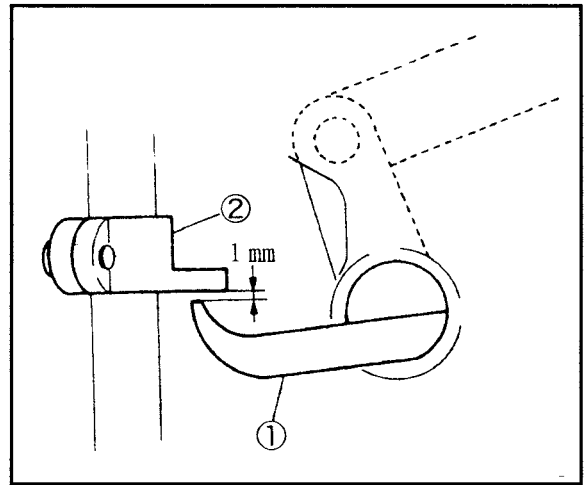

Fig. 6

Adjusting :

- (1) Remove the seal plugs ③ ④ to check the clearance. (Fig. 8)
- (2) Loosen the screw ⑤ of the presser foot lifter lever link (long).
- (3) Move the presser foot lifter lever link (short) ⑥ right or left to adjust the clearance.(Fig. 9)

調整：

- (1) 移除油塞 ③ ④ 才可以檢查間隙。(Fig. 8)
- (2) 放鬆壓腳連接桿螺絲 ⑤。
- (3) 移開壓腳連接桿(短) ⑥ 右邊或左邊去調整間隙。(Fig. 9)

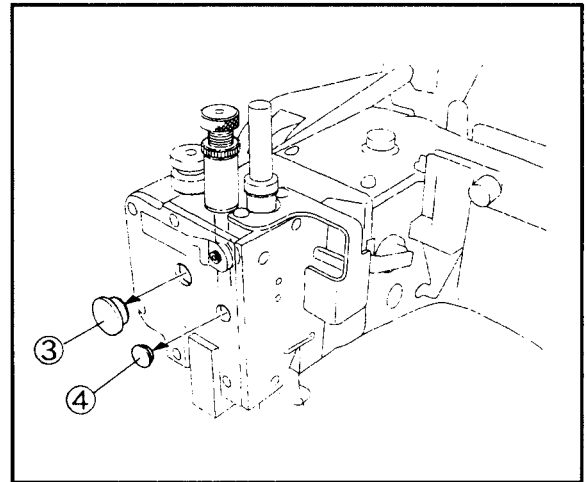

Fig. 7

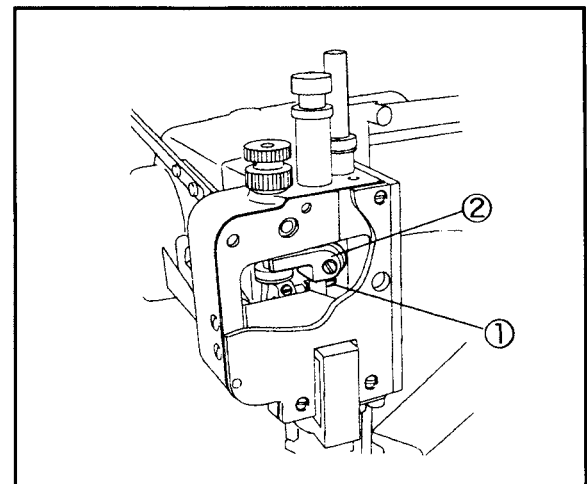

Fig. 8

CAUTION

After adjusting the clearance of the presser bar lifter lever ①, adjust the presser foot lift at the lowest point of the presser bar.

If not adjusted, it can cause damage to the top cover thread hook.

注意

在調整抬壓條連接軸①之後，調整抬壓腳在壓腳的最低位置。

如果沒有調整會導致上網線勾損壞。

2. As standard, make the clearance between the notch of the needle clamp ① and the top cover thread hook ② to 0.3mm when the needle bar is at the lowest point and the presser foot is raised by pressing the presser foot pedal fully. (Fig. 10)

當針柱在最低位置和壓腳完全抬舉時，針鏹和上網線勾需留間隙 0.3mm。(Fig. 10)

Adjusting :

- (1) Loosen the lock nut ③ .
- (2) Move the presser foot lifter stop plunger ④ in or out to adjust the clearance. (Fig. 11)

調整：

- (1) 放鬆螺母③。
- (2) 移動抬壓腳停止插銷④或再調整外面間隙。(Fig. 11)

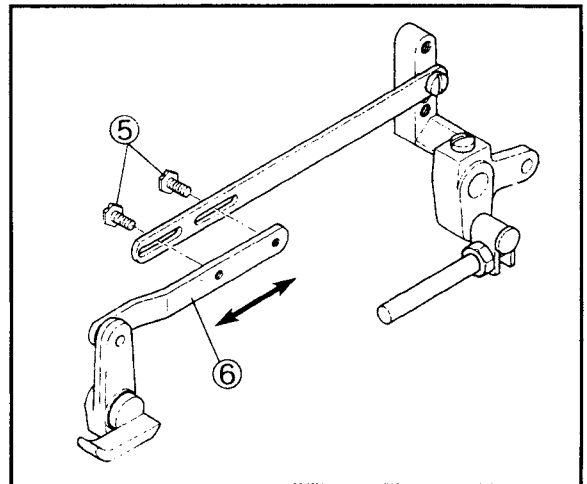

Fig. 9

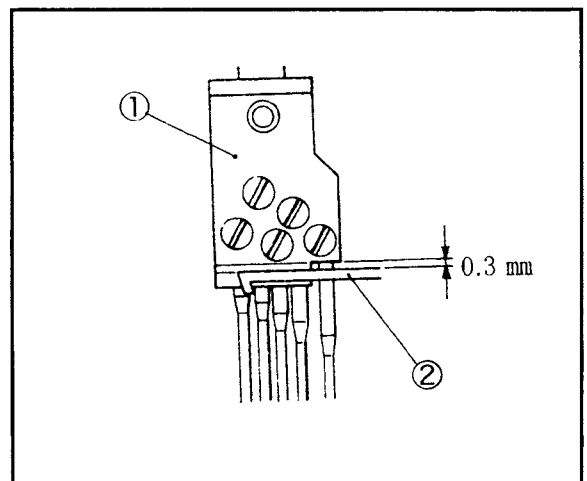

Fig. 10

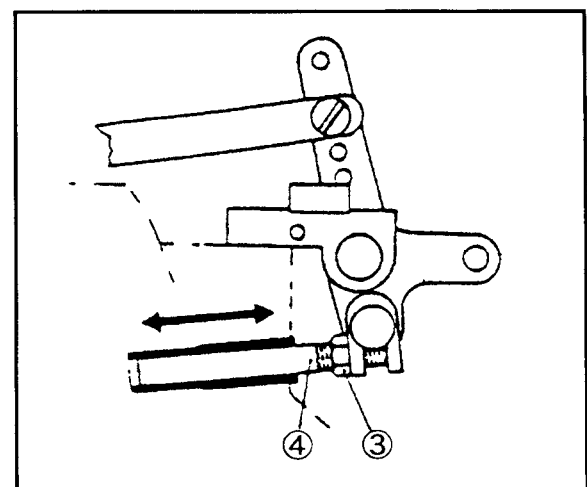

Fig. 11

2.2.3 Tension release unit

2.2.3 過線組

As standard, make the clearance between the tension release pins ① and the tension release shaft ③ to 0.5 mm when six tension release pins ① are pushed up slightly and the upper thread tension disc ② starts leaving from the lower thread tension disc without pressing the presser foot pedal. (Fig. 12)

不踩板時凸線器①和凸線器座③之間要有0.5mm的間隙。

當踩下踏板時，六個凸線器①會向上推，然後夾線片②開始離開下夾線片。(Fig. 12)

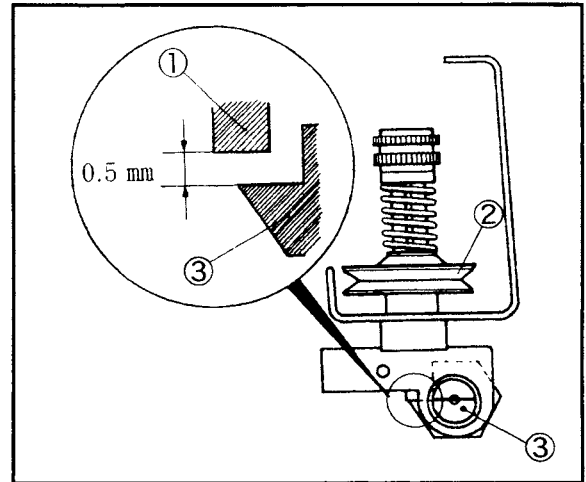

Fig. 12

Adjusting :

- (1) Loosen the screw④of the persser bar lifter lever (large).(Fig. 13)
- (2) Turn the tension release shaft③with a screwdriver. (Fig. 12)

- To decrease the clearance, turn it clockwise.
- To increase the clearance, turn it counterclockwise.

調整：

- (1) 放開提昇擺臂(大)的螺絲④。(Fig. 13)
- (2) 翻轉凸線器座③用螺絲起子。(Fig. 12)

- 順時針旋轉去減少間隙。
- 逆時針旋轉去增加間隙。

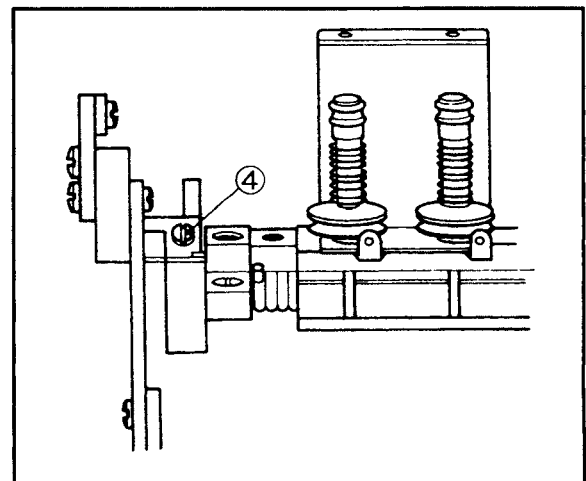

Fig. 13

2.3 Motor and belt

2.3 馬達和皮帶

See the instruction manual for the motor to be used and install the motor properly.

To install the clutch motor, align the center of the machine pulley with that of the motor pulley when the motor pulley shifts to the left with toeing down the pedal.

(Fig. 14)

正確的使用方式和安裝方式，請看說明書。

安裝馬達時，機器皮帶和馬達皮帶輪的中心線需成一直線。(Fig. 14)

NOTE :Table 1 shows the outside diameter of the motor pulley, rpm of the machine, and size of the belt when using the clutch motor of 3-phase, 2-pole, 400W(1/2HP).

The outside diameter on the table shows the nearest size to the calculated values based on the commercial pulleys at intervals of 5 mm.

提醒：表格1顯示縫紉機和馬達皮帶輪之外徑對照表，當使用第3個階段，2-皮帶輪的尺寸適合400W的離合器馬達(1/2HP)。

皮帶輪每增大尺寸間隔為5mm。

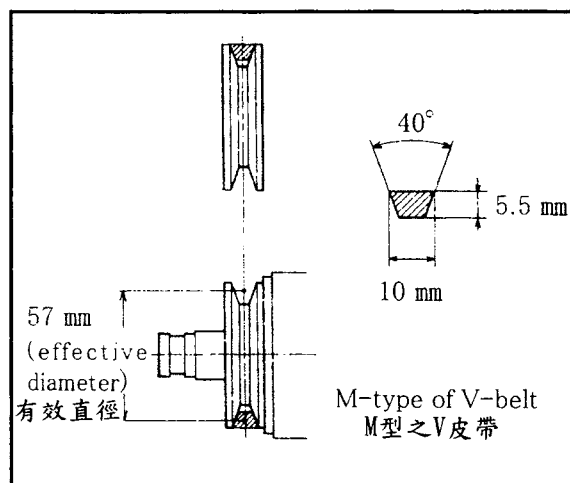

Fig. 14

Outside diameter of pulley (mm) 皮帶輪外徑	rpm of machine 機器轉數		Size of belt 皮帶尺寸 Table top type	
	50Hz	60Hz	clutch motor 控制馬達	servo motor 伺服馬達
45		2600	M32	M31
50		2900	M32	M31
55	2700	3200	M32	M31
60	2900	3500	M33	M32
65	3150	3800	M33	M32
70	3400	4100	M33	M32
75	3650		M34	M33
80	3900		M34	M33
85	7500		M34	M33

Table 1

CAUTION

Use only those motor pulleys applicable to the machine. If not, the sewing speed will be over maximum and it can cause the machine damage.

注意

只可使用適合之皮帶輪。如果使用速度超過最大上限機器會有損壞的可能性。

2.4 Hanging belt

2.4 皮帶鬆緊

WARNING

Before hanging belt, ALWAYS turn the motor switch OFF and check that motor has already stopped.

注意

掛上皮帶前要先關掉馬達，確定馬達完全停止運轉，然後配合手轉動皮帶輪，使之掛上皮帶。

Use the M-type of V-belt. (Fig. 15)

- (1) Hang the belt ① on the machine pulley ②, and then on the motor pulley while rotating the machine pulley.
- (2) Adjust the belt tension so that the belt has 10-20mm slack when its center is pushed with 10 N(1.02 kgf).
- (3) Fix the motor with the adjusting bar.

使用M型之V皮帶 (Fig. 15)

- (1) 掛上皮帶①到機器皮帶輪上面②然後轉一下皮帶輪。
- (2) 調整皮帶鬆緊使皮帶有10-20 mm的鬆緊度，當對皮帶中點施10 N 的力。(1.02 kgf)
- (3) 校正馬達。

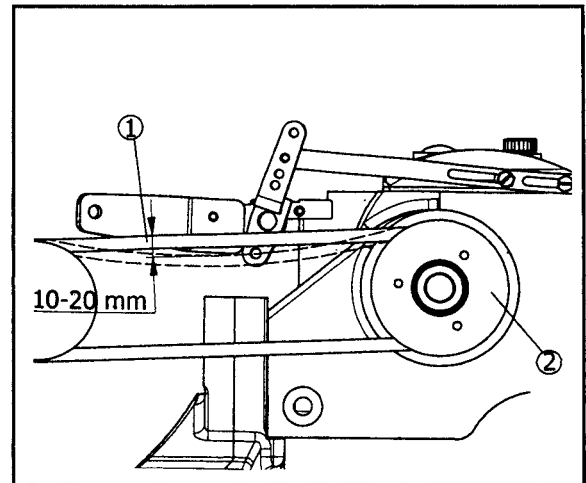

Fig. 15

2.5 Belt cover

2.5 皮帶護蓋

WARNING

Be sure to install belt cover to prevent you from injuring and a material from being caught by the belt.

注意

確實裝好皮帶護蓋，以免受傷，並避免皮帶碰觸機身。

Table top tpye-CL (Fig. 16)

- (1) Set the belt cover①on the sewing machine supporting block②with the screw④and the washer⑤.
- (2) Fix the belt cover①on the sewing machine supporting block③with the screw⑥and the washer⑦.

桌上型皮帶護蓋-CL普通馬達 (Fig. 16)

- (1) 安裝皮帶護蓋①到支稱塊②要用螺絲④墊片⑤鎖緊。
- (2) 固定皮帶護蓋①到支稱塊③要用螺絲⑥墊片⑦鎖緊。

Table top tpye-SV

- (1) Set the belt cover⑧on the sewing machine motor cover⑩with the screw⑬and the washer⑭.
(Fig. 17)
- (2) Fix the belt cover⑧on the sewing machine motor cover⑨with the screw⑪and the washer⑫.
(Fig. 18)

桌上型皮帶護蓋-SV伺服馬達

- (1) 安裝皮帶護蓋⑧到馬達蓋座⑩要用螺絲⑬和墊片⑭鎖緊。(Fig. 17)
- (2) 固定皮帶護蓋⑧到馬達蓋座⑨要用螺絲⑪和墊片⑫鎖緊。(Fig. 18)

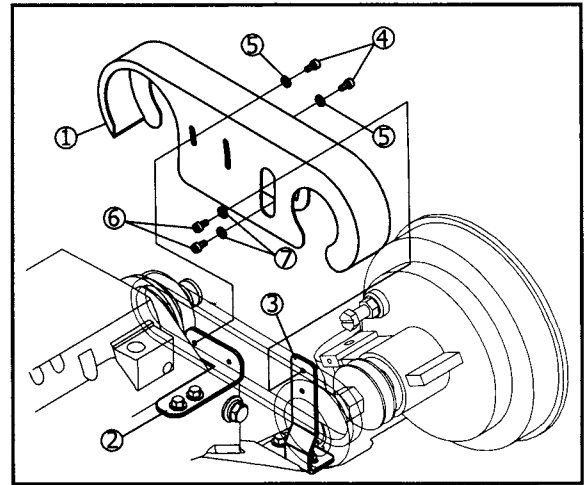

Fig. 16

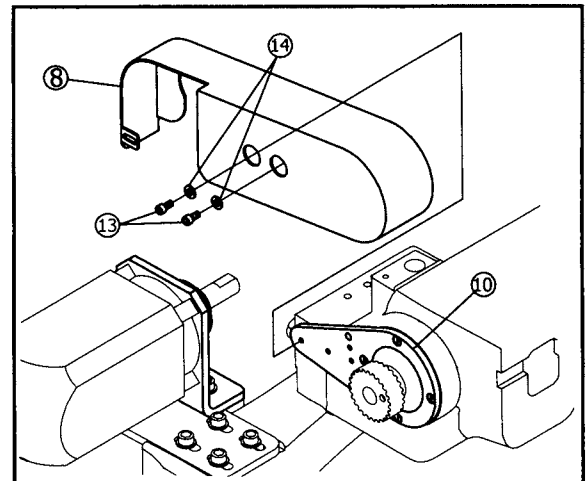

Fig. 17

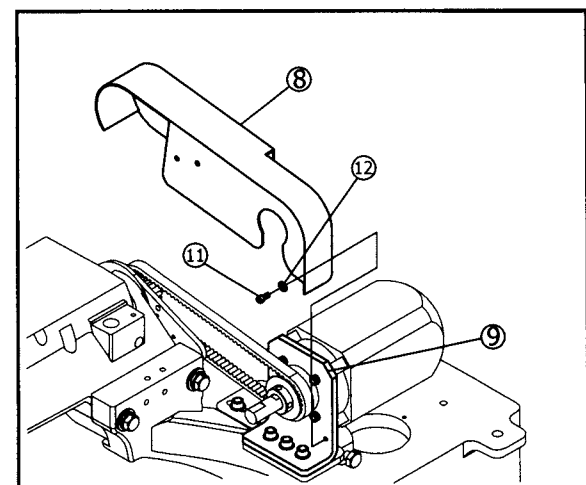

Fig. 18

2.6 Other parts

2.6 其它部份

Setting thread eyelets :

Stand the thread guide plate supports③on the thread tension support⑦and fix the thread guide plate④on the supports③with the screws⑤.

Adjust the thread pipes⑥to thread smoothly without entangling. (Fig. 19)

安裝機頭線架：

將線架支柱③裝在線架固定座⑦，再將過線架④用螺絲⑤鎖在線架支柱③調整過線桿⑥，使穿線平順，不致於線會糾結在一起。(Fig. 19)

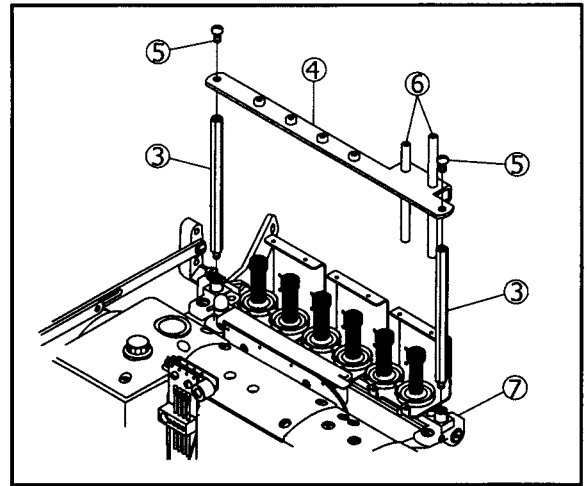

Fig. 19

Handwheel

Table top type :

Fix the motor pulley①with the handwheel shaft②. Fix the handwheel③to the handwheel shaft②. (Fig. 20)

手輪

桌上型：

將馬達皮帶輪①裝在手輪軸②。再將手輪③裝在手輪軸②。(Fig. 20)

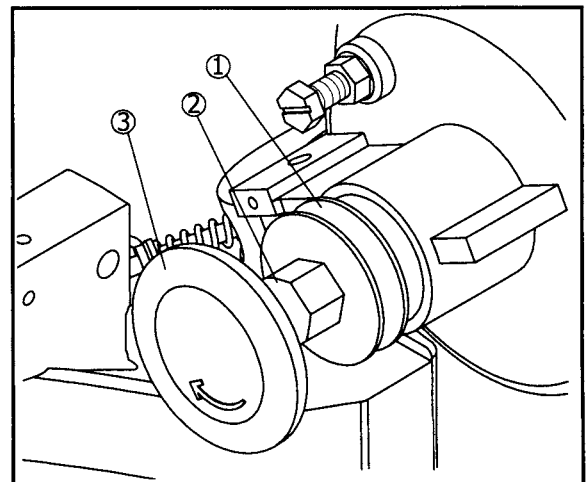

Fig. 20

3. Sewing speed and rotating direction of pulley

馬達轉速和皮帶輪轉動方向

The sewing speed is 4200 rpm at the maximum and 3800 rpm is usual.

Run a new machine at a speed of 15-20 % lower than maximum sewing speed during the first 200 hours (for about one month) so that the machine can offer a long service life in good condition.

The rotating direction of the motor pulley① and the machine pulley② is clockwise from the operator side.

機器轉速4200為最高速，平常使用3800轉。
在前200個小時(約一個以月)使3000-3360轉左右的速度，這樣機器使用時間可以延長。

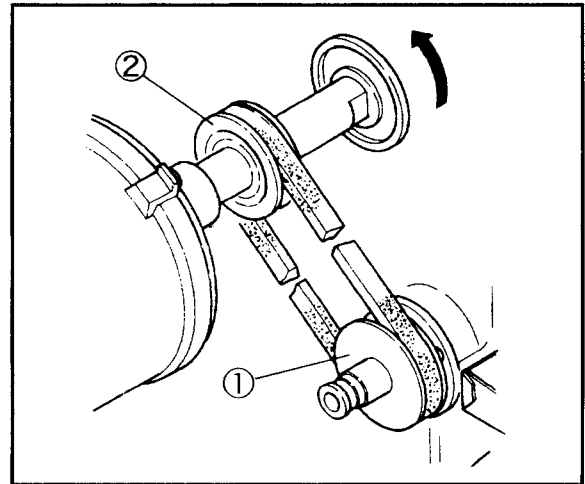

Fig. 21

皮帶輪①和機器皮帶輪的運轉方向是順時針。

CAUTION

If rotating in reverse direction, oil can not be supplied properly. It can cause the machine damage.

注意

如果運轉方向相反，油無法供應，會造成機器損壞。

4.1 Lubricating oil

4.1 潤滑油

CAUTION

NEVER add additives to the oil.

If added, it can cause the deterioration of the oil and the machine damage.

注意

絕對不要在油內再加人任何添加物(劑)，否則將惡化油的品質並損害機器。

(使用32T系數之油品)

4.2 Lubricating

4.2 潤滑系統

Remove the plug screws①and②indicated " OIL " and supply oil.

From the plug screw①, supply oil until the oil level indicator top reaches the upper line in the oil sight gauge③. Form the plug screw②, supply oil to the upper line in the oil sight gauge④.

Check the oil level between the lines in the oil sight gauges③and④before running a machine.

If it is under the lines, supply oil.

Check the oil splashes from the nozzle inside the oil sight top windows⑤and⑥when starting to run a machine.

旋開油塞螺絲①和②然後加油。

從油孔①加油直到油量到③最上方的紅線，從②加油直到油量到④最上面的紅線。

使用機器前檢查油水平。如果沒到水平線要加油。當機器在使用中時，檢查油有無供應從油鏡⑤和⑥。

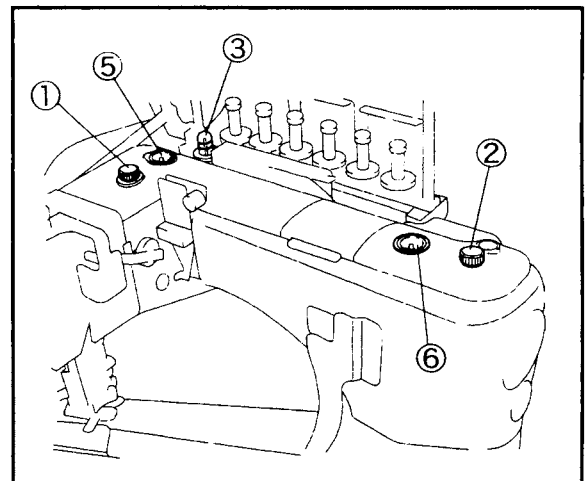

Fig. 22

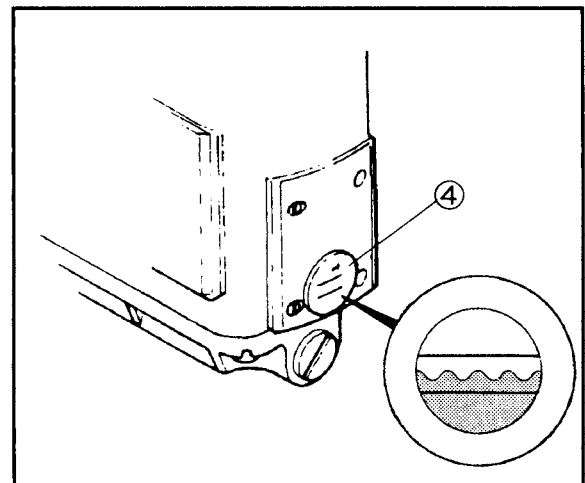

Fig. 23

CAUTION

Too much oil not enough oil can cause oil leakage and machine trouble. Be sure to keep the oil level between the lines.

太多或太少的油會造成機器漏油和機器故障。維持油的水平在2條之間。

4.3 Priming oil

4.3 啟動注油

Prime oil if oil does not circulate completely when installing a new machine or running a machine which has not been used for a while.

Remove the plug screws① of the pump driven gear to prime oil. Run a machine after resetting them①. (Fig. 24)

如果油沒有循環完整，在裝新機器或使用久未使用的機器。

移除幫浦上的油塞螺絲①注入油後裝回螺絲再使用機器。(Fig. 24)

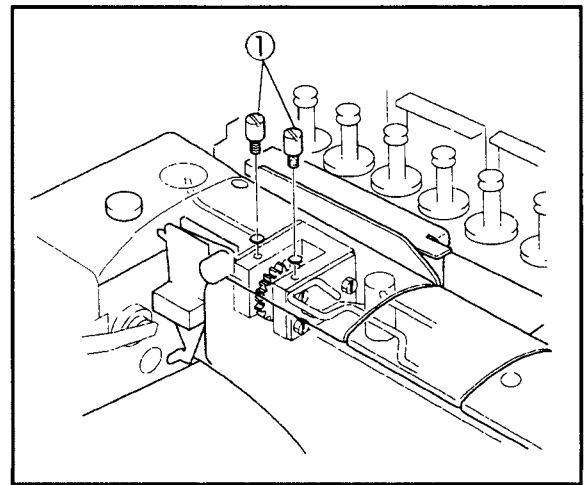

Fig. 24

4.4 Replenishing oil

4.4 補充油

Replenish a drop of oil from the points indicated arrows with an oiler (accessories) if needed.

If oil leaks around the presser foot and the upper knife, it can cause oil stain on the material. Be sure to wipe it completely. (Fig. 25)

在箭頭處需滴一些油潤滑。如果漏油在壓腳和上刀周圍會導致沾汙布，要確實的把油擦乾淨。(Fig. 25)

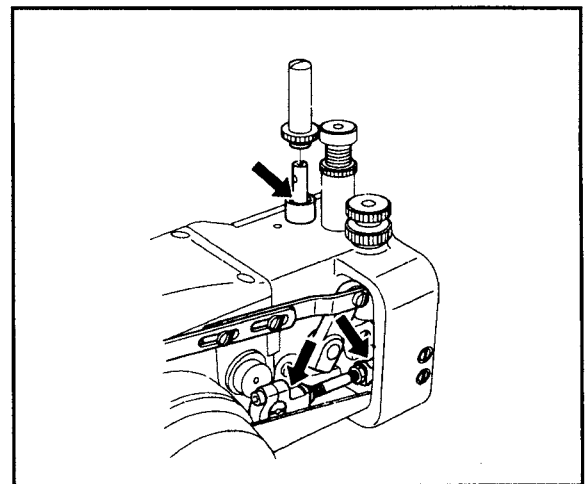

Fig. 25

CAUTION

Too much lubrication can cause oil scatter and material stain.

注意

太多的潤滑油會使布料沾汙。

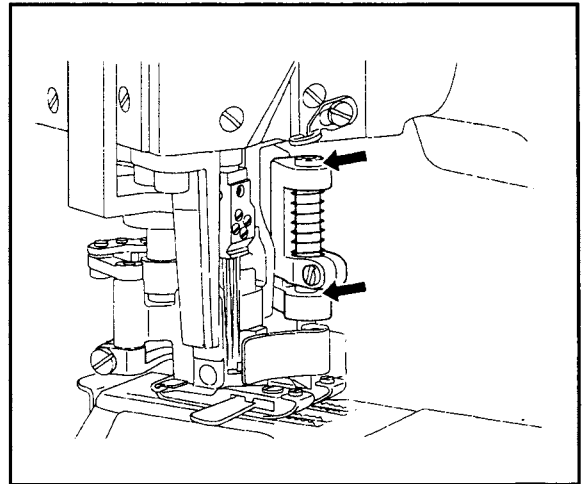

Fig. 26

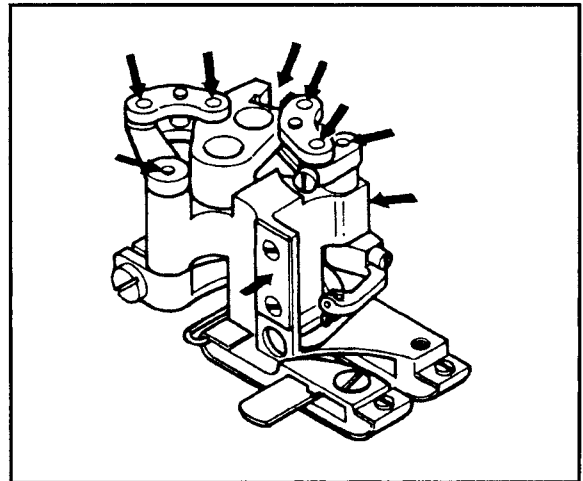

Fig. 27

4.5 Changing oil

4.5 更換油

Period of changing :

When using a new machine, change the lubricating oil after running for 200 hours (for about one month). After that, change the oil once or twice a year.

換油時機：

新機使用200小時(約使用一個月)後，要更換新油，之後，每年換新油1~2次。

Procedrue for changing :

- (1) Remove the belt cover. (See page 10)
- (2) Set containers received the oil under the screws① and②respectively.
- (3) After removing screws①and ②, the oil is drained.

換油程序：

- (1) 拆開皮帶蓋。(如第10頁)
- (2) 分別在螺絲①②下面放置接油容器。
- (3) 拆下螺絲①和②後，油流出。

NOTE

Be careful not to soil the V-belt and the machine pulley with the oil.

注意

勿將油弄髒皮帶以及機器轉輪。

- (4) Reset the screws①and ②.
- (5) Fill the new oil. (See "4.2 Lubrication")
- (6) Reset the belt cover.
- (4) 裝回螺絲①和②。
- (5) 注入新油。(參考"4.2 潤滑系統")
- (6) 裝好皮帶蓋。

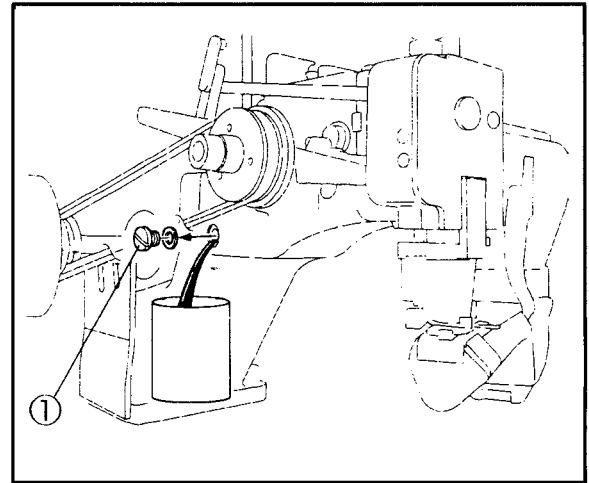

Fig. 28

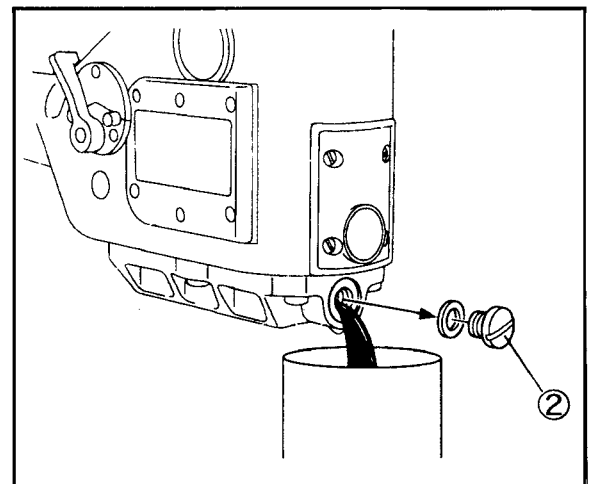

Fig. 29

5.1 Needle system

5.1 車針系列

Sewing needle :

Groz-Beckert UY118GKS

Organ FLX118GCS

Select the proper sewing needle in size depending on thickness and type of material.

縫紉機用針 :

格洛茲貝克牌 UY118GKS

風琴牌 FLX118GCS

選用適合的針給不同的材料。

Retainer needle :

One retainer needle is used with four sewing needles.

Groz-Beckert 36211, 36211A (with scarf)

Organ FLG-1, FLG-8 (with scarf)

Select the proper retainer needle in size depending on thickness and type of material.

假針 :

一支假針配合四支針。

格洛茲貝克牌 36211, 36211A

風琴牌 FLG-1, FLG-8

選擇適合的假針去使用不同的材料。

Japanese standard 日本規格	8	9	10	11	12	-	14
Metric standard 公制規格	60	65	70	75	80	-	90

Table 2

Note : Some needles have not been sold in size.

Check the size in a manufacturer's catalog.

提醒：有些尺寸並沒有販售，請從目錄上確認尺寸。

Japanese standard 日本規格	8	9	10	11	12
Metric standard 公制規格	60	65	70	75	80

Table 3

Note : Some needles have not been sold in size.

Check the size in a manufacturer's catalog.

提醒：有些尺寸並沒有販售，請從目錄上確認尺寸。

5.2 Installing needle

5.2 針的安裝

WARNING

Before installing the needles, ALWAYS turn the motor switch OFF and check that the motor has already stopped.

注意

安裝針之前一定要先把馬達關掉和確定馬達不會動。

The shank of the needle includes the flat parts. Insert needles into the inmost point of the needle clamp, and tighten them with the screws①. (Fig. 30)

將針插到針鑷的最頂端然後鎖緊用螺絲①。(Fig. 30)

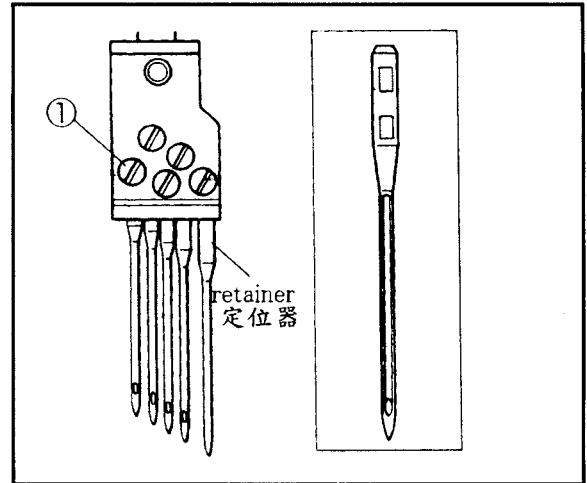

Fig. 30

Replacing needle :

- (1) Rotate the handwheel to raise the needles at the highest point.
- (2) Loosen the screws①and pull the needles down.
- (3) Face the flat parts front, insert new needles into the needle clamp②as far as they will go. Tighten them with the screws①securely.

替換針：

- (1) 旋轉轉輪將針抬到最高點。
- (2) 放鬆螺絲①把針拔下來。
- (3) 平面擺在前方將新針放入針鑷②內最頂端，然後鎖緊螺絲。

WARNING

Before threading, ALWAYS turn the motor switch OFF and check that the motor has already stopped.

注意

穿線前，一定要先把電源關掉還有確定馬達完全停止。

5.3 Threading

5.3 線

Thread correctly, referring to Fig. 31.

A, B, C, D : Needle thread ... When threading, pull the thread out until it is in front of the needles.
Then cut off the knot before needle eye to rethread.

E : Top cover thread When threading, pull the thread out until the knot is out.

F : Lower looper thread Then cut off the knot.

正確穿線，參考圖31

A, B, C, D : 針線 先用易穿的線從ABCDEF孔穿至針鐮前，然後結上要用的線拉到針前把結剪掉。

E : 上蓋線 當穿線時把線結剪掉，再穿入針孔。

F : 下輪線

Easy to use

When raising presser foot,
thread tension will be released
to take up smoothly.

簡易方法

當抬起壓腳時，
線架組會平穩的放開。

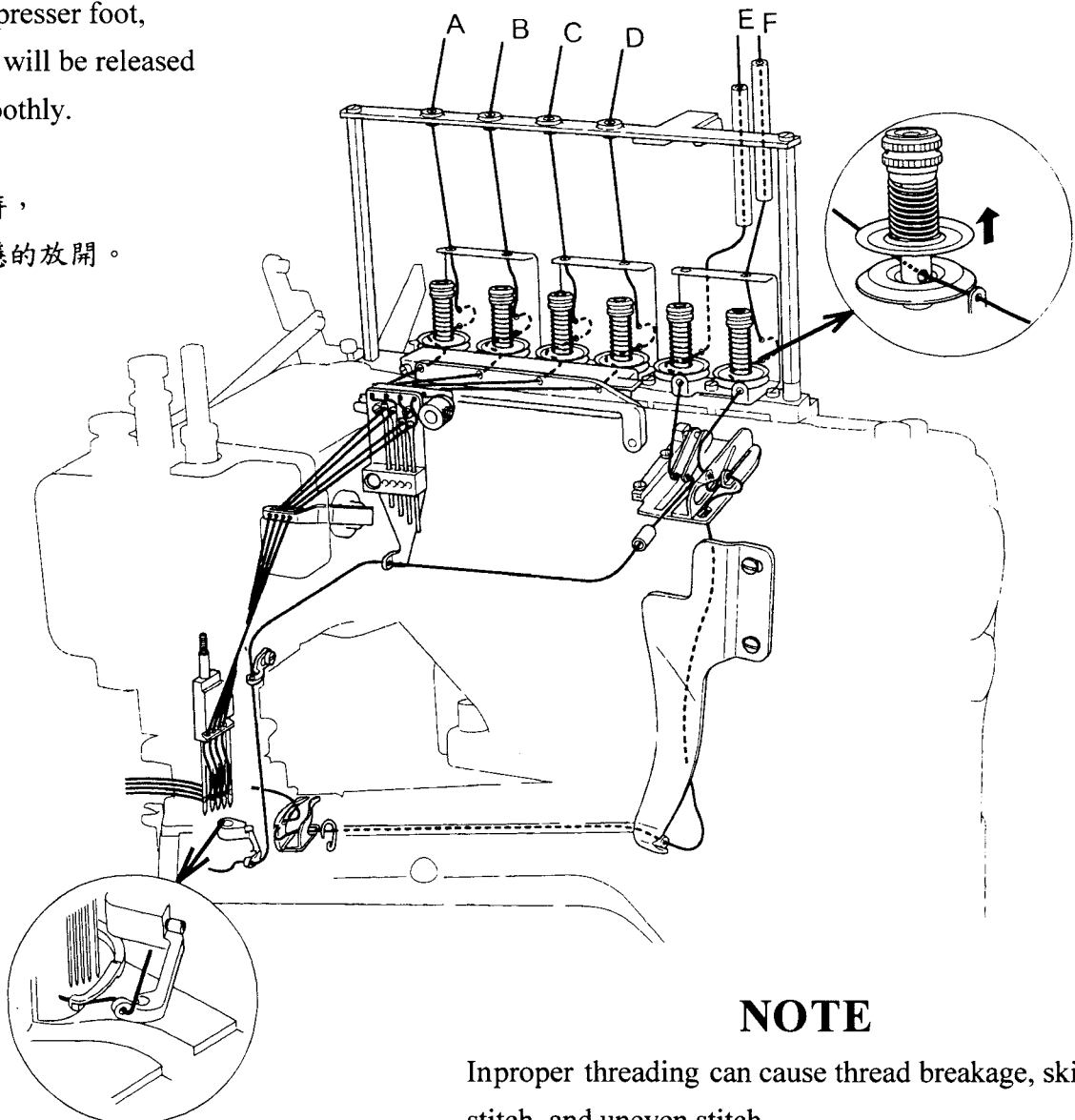

NOTE

Inproper threading can cause thread breakage, skip stitch, and uneven stitch.

提醒：穿下鉤針線時不須把針板拆掉。

Fig. 31

5.4 Thread tension

5.4 線鬆緊

Adjust the thread tension with the tension adjusting nuts ①-⑥ depending on fabric type, thread type, seam width, stitch length, and other sewing conditions.

① - ④: needle threads

(①: right needle, ④: left needle)

⑤: top cover thread

⑥: looper thread

調整線架上的鬆緊度是靠螺母①-⑥取決於布線寬度和其它狀況。

①-④: 針的線

(①: 右針, ④: 左針)

⑤: 上網線

⑥: 下網線

- To tighten the thread tension, turn the nuts clockwise.
- To loosen the thread tension, turn nuts counterclockwise.
- 如果調緊線時以順時間方向調下①-⑥螺絲。
- 如果調鬆線時以逆時間方向調上①-⑥螺絲。

5.5 Pressure of presser foot

5.5 調整壓腳壓力

Loosen the lock nut ⑦ and turn the adjusting screw ⑧ to adjust the pressure.

放鬆螺母⑦然後用壓腳柱螺帽⑧來調壓力。

- To increase the pressure, turn the adjusting screw ⑧ clockwise.
- To decrease the pressure, turn the adjusting screw ⑧ counterclockwise.
- 增加壓腳壓力時，順時間調整螺帽⑧。
- 減少壓腳壓力時，逆時間調整螺帽⑧。

Keep the pressure as low as possible for stable stitches.
儘可能保持壓腳壓力在最鬆的狀態使布在針板上更加平穩。

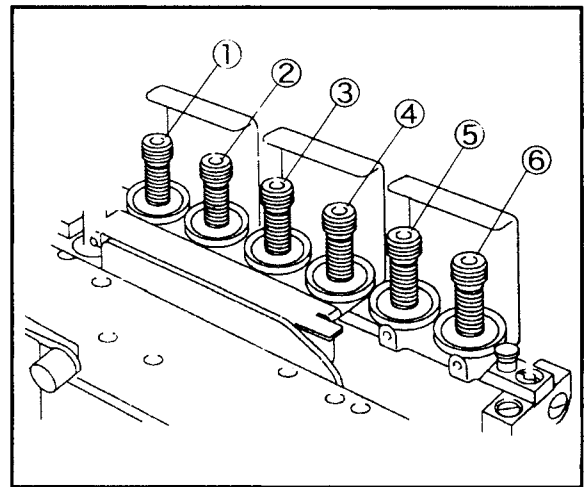

Fig. 32

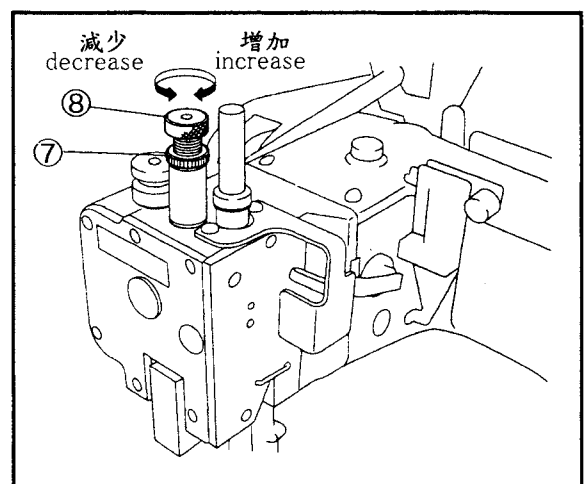

Fig. 33

5.6 Up-and-down position of presser foot

5.6 調整壓腳高低

Following effective points will be obtained by slightly raising the presser foot.

輕微的調高或降低壓腳都會有明顯的成效。

- Prevention of fabric jam
- Prevention of feed scratch mark
- Improvement of durability of presser foot spring plate
- Reduction of vibration and noise
- Available for fine adjustment of lapped fabric width
- 預防勾齒抓痕
- 改善壓腳彈片的耐久度
- 增減壓腳彈簧片的壓力度
- 減少噪音和振動
- 可細微的調整針織的寬度

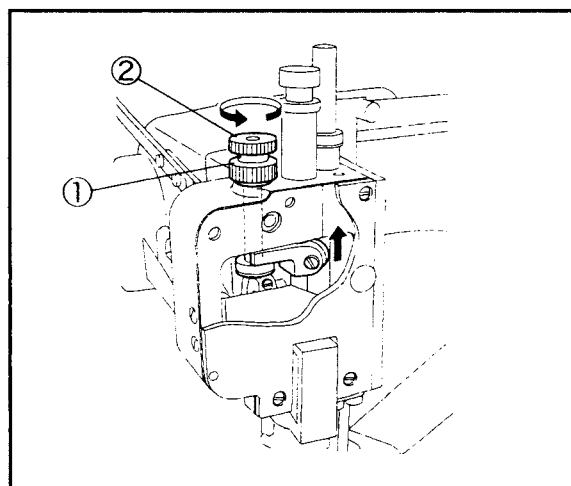

Fig. 34

- (1) Position the needle at the lowest point.
- (2) Loosen the lock nut①and turn the adjusting nut ②counterclockwise to raise the resser foot.
- (3) Adjust the clearance between the bottom④of the presser foot and the presser foot spring plate③to 0.3-0.5 mm.

- (4) Tighten the lock nut①securely.

- (1) 針在最底點的位置。
- (2) 鬆開螺絲①然後逆時旋轉調整螺母②抬起壓腳。
- (3) 在壓腳④和壓腳彈片③之間調整出口0.3-0.5 mm的間隙。
- (4) 把螺母①鎖回去。

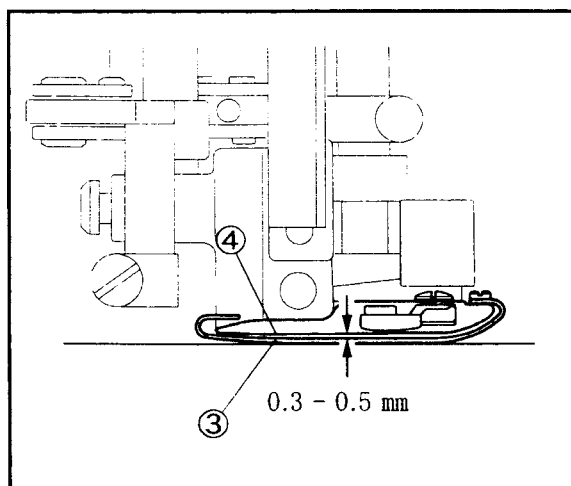

Fig. 35

5.7 Adjusting differential feed dog

5.7 調整差動

Move the differential feed operating lever⑤right or left to adjust differential feed dog.

移動調整桿向右或左去調整差動整桿⑤在刻度"4"和刻度"5"之間是相同的動作和差動。

The lever⑤between the graduations "4" and "5" makes the equal movement of the main and the differential feed dogs.

差動比調整桿⑤定位在刻度"4"與"5"之間時，主牙與差動牙的運作相同。

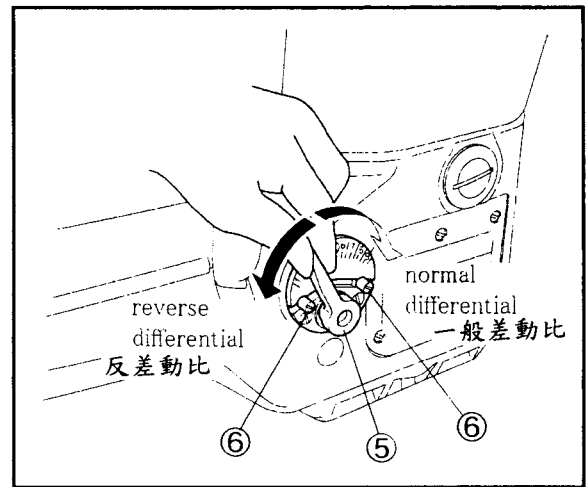

Fig. 36

- To make normal differential, move the lever⑤to "9".
- To make reverse differential, move the lever⑤to "1".
- 一般差動比調整桿⑤調到刻度"9"的位置。
- 反差動比調之桿⑤調到刻度"1"的位置。

* The screw⑥is for fixing the lever⑤and keeping the differential movement adjusted.

* 螺絲⑥是用來固定調整桿⑤和保持差動的多或少。

WARNING

Before adjusting, ALWAYS turn the motor switch OFF and check that the motor has already stopped.

注意

在調整機器之前，一定要先把電源關掉還有確定馬達完全停止。

5.8 Adjusting stitch length

5.8 調整針距

Stitch length ranges 1.6 - 2.5 mm as standard and can be adjustable infinitely.

粗細針的範圍1.6-2.5mm是標準但可以調整至更大。

Adjusting : (Fig.38)

- (1) Loosen the screw①and move the needle guard (rear)②most rearward. Then tighten it slightly.
 - * This is skipped when decreased the stitch length.
- (2) Remove the plug screw③.
- (3) Loosen the screw④to adjust the stitch length.
 - To increase stitch length, move the screw④upward.
 - To decrease stitch length, move the screw④downward.
- (4) Tighten the screw④securely and reset the plug screw③.

調整：(圖38)

- (1) 放鬆螺絲①，移動針檔②(後)到最後面。然後輕微鎖緊。
 - * 當在減少針寬時可以省略。
- (2) 退掉油塞螺絲③。
- (3) 放鬆螺絲④去調整粗細針。
 - 增加針距時將螺絲④向上調整。
 - 減少針距時將螺絲④向下調整。
- (4) 鎖緊螺絲④和重新裝上油塞螺絲③。

Adjusting : (Fig.38GX)

- (1) To increase stitch length, moves the lever④ to the direction of scale "1".
- (2) To decrease stitch length, moves the lever④ to the direction of scale "9".

調整：(圖38GX)

- (1) 增加針距時將調整桿④往刻度"1"的方向。
- (2) 減少針距時將調整桿④往刻度"9"的方向。

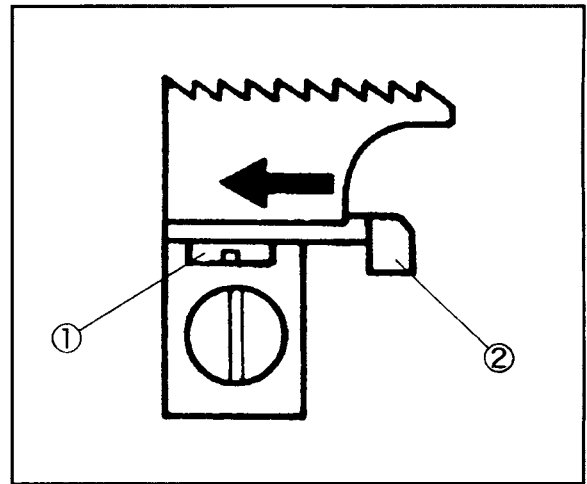

Fig. 37

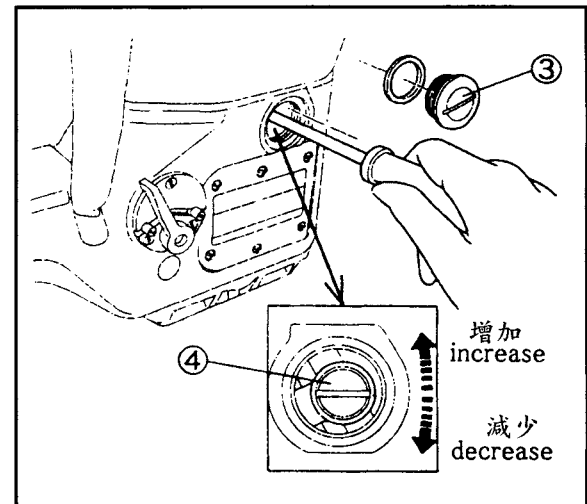

Fig. 38

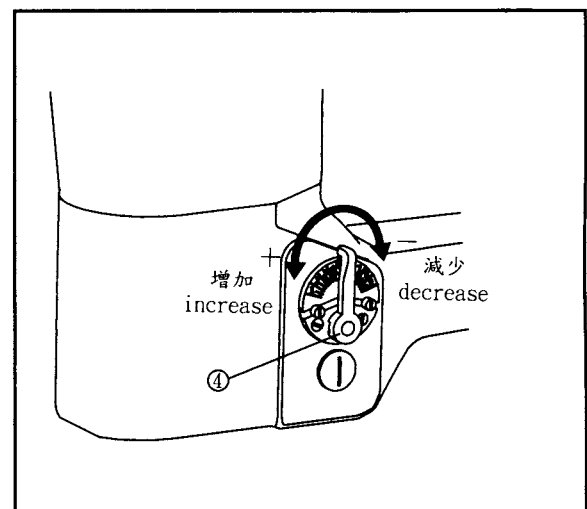

Fig.38GX

(5) Adjust the position of the needle guard(rear)②and tighten the screw①securely. See "6.8 Needle guard (rear)"

(5) 調整針檔②位置然後鎖緊螺絲①。參考"6.8後針檔"。

Table 4 shows the number of stitches per inch (25.4mm) and 30 mm converted stitch length.

圖表4針距大小使用1英吋表示說每英吋減每30mm的距離有幾針。

CAUTION

Be sure to adjust needle guard(rear) after changing stitch length to prevent breakage of the parts.

注意

調整針距時必須注意後針檔的位置。

Advice adjustment

Always adjust stitch length after changing differential feed dog.

調整建議

在每次更換不同的勾齒之後要調整粗細針。

Stitch length (mm) 針距	Number of stitch (per 1 inch) (25.4mm) 針數	Number of stitch (per 30mm) 針數
2.5	10	12
2.1	12	14
1.8	14	16.5
1.6	16	19
1.2	21	25
1	25	30

Table 4

WARNING

Before adjusting, ALWAYS turn the motor switch OFF and check that the motor has already stopped.

注意

在調整機器之前，一定要先把電源關掉還有確定馬達完全停止。

5.9 Adjusting lapped width of upper fabric

5.9 調整切布刀

For the standard position of the lower knife①, make the distance between the lower knife①tip and the lower knife clamp②to 0 -0.5 mm. (Fig. 39)

底刀①的標準位置要留距離在底刀①尖端和鎖底刀座②之間0-0.5 mm。(Fig. 39)

For the standard position of the upper knife③, engage between the upper knife③and lower knife①to 0.5 mm when the upper knife③is at the extreme left. (Fig. 40)

上刀的轉接位置當上刀③在最左邊時，上刀③和底刀①要有0.5 mm的重疊。(Fig. 40)

To move the fabric edge right or left, position the lower knife①, and then move the upper knife to engage between the knives to 0.5 mm.

Loosen the screws④and⑤to adjust the lower and upper knives respectively.

移動刀口到左或右底刀①的位置，然後移動上刀使其跟底刀有0.5 mm的間隙。

放鬆螺絲④和⑤去調整上刀和底刀。

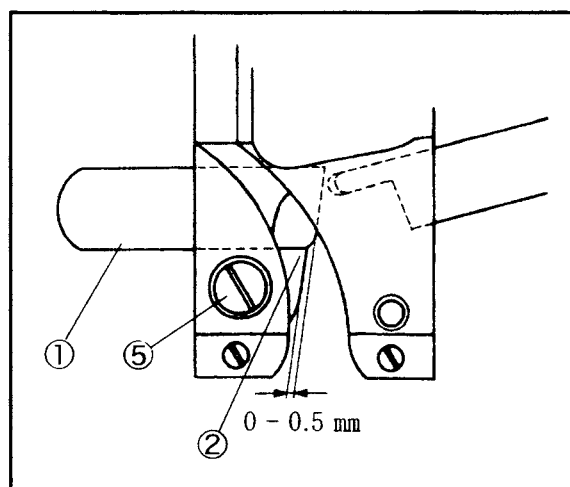

Fig. 39

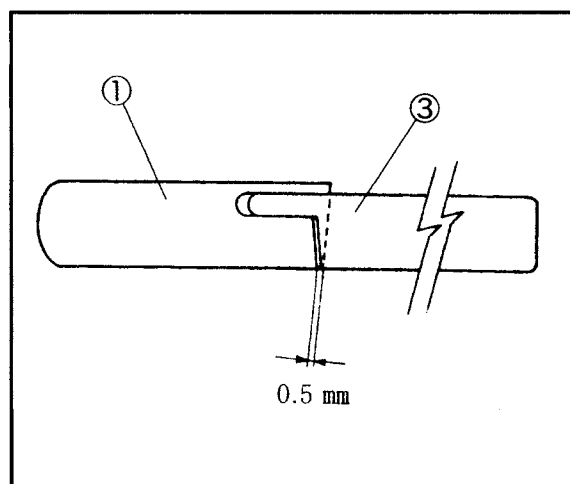

Fig. 40

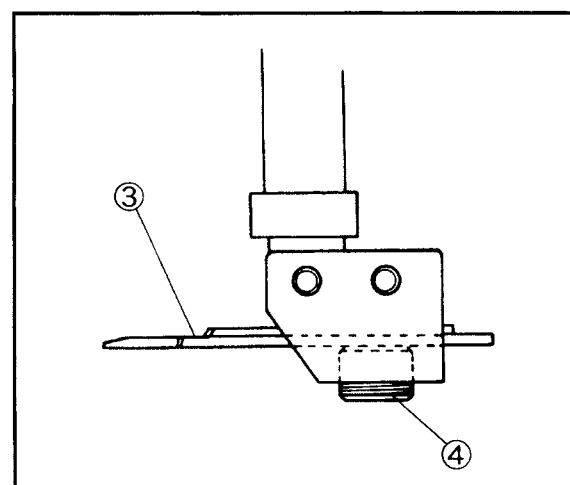

Fig. 41

5.10 SP device

5.10 過線油組

SP device (needle thread oiling) is equipped as standard to prevent thread breakage and skip stitch when running a machine at high speed or using synthetic thread and/or synthetic fabric.

Fix the felts①included accessories into the SP tank② when using.

當機器在高速運轉或使用特殊線或特殊纖維時，矽油壺組是標準配備，以防止斷線跳針。

當使用機器時，將毛氈①放入矽油壺②內。

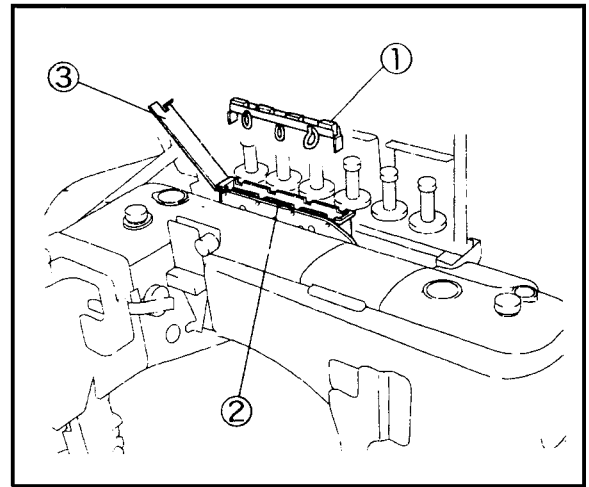

Fig. 42

CAUTION

1. When not using SP device, remove the felts①. If not, it may occur irregular condition during sewing.
2. If the silicone oil sticked to the parts other than SP device, it can cause the machine damage. Be sure to wipe it away.

注意

1. 當不使用矽油壺組時，要取出毛氈①。不然可能在車縫時發生不正常情況。
2. 當矽油沾到其他零件時，可能引起機器損傷。故要將油擦乾淨。

Use dimethyl silicone oil.

Open the oil cup lid③and check the oil amount.

If not enough, supply oil into the SP tank②.

使用乙烷樹脂

打開油壺蓋③，檢查油量。如果不夠，添加油於油壺②。

5.11 Use of lap former

5.11 導布器

Standard left-and-right position :

Align the point A of the lap former①with the center of four needles.

調整左右邊的標準位置：

導布器上的A點要跟4支針的中間成一直線。

Depending on lapped edges of the fabrics or fabric feeding, loosen the screws④and adjust the position.

鬆開螺絲④和調整位置視刀的邊緣和刀齒。

Standard front-and-rear position :

Set the position where the lap former slide block②touches and stops in the front of the sitich plate③.

調整前後的標準位置：

設定滑塊②停止的位置在針板③前。

Depending on fabric thickness, adjust the position slightly toward the operator.

視刀厚去輕微的調整位置。

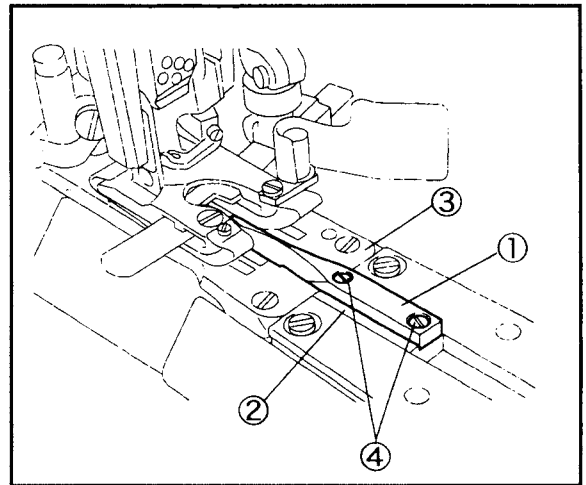

Fig. 43

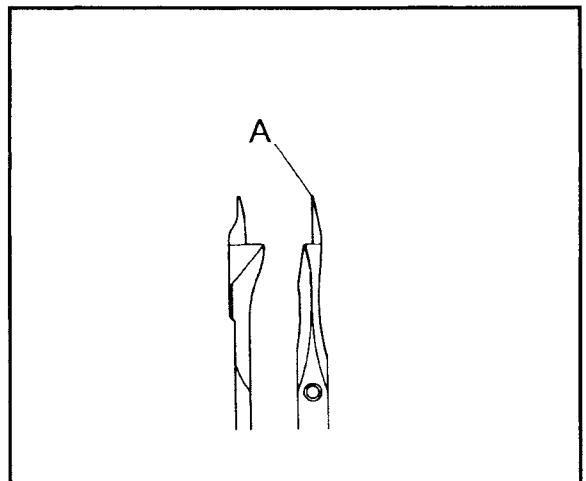

Fig. 44

Part No.	Applicable model
零件號碼	適用機型
P27-36	MJ62-02

WARNING

Before adjusting, ALWAYS turn the motor switch OFF and check that the motor has already stopped.

注意

在調整機器之前，一定要先把電源關掉還有確定馬達完全停止。

6.1 Needle thread tension

6.1 針線鬆緊

Needle thread strike-off pin:

Each of four needles has the needle thread strike-off pin which adjusts the thread tension respectively.

針線線圈調整片：

4支針各有自己的過線片可以調整線圈的鬆緊。

- (1) Position the needle thread take-up ① at the lowest point.
- (2) Set the top of pin ② even with the needle thread as the fourth right needle.
- (3) Set the pin ③ 3.2 mm higher than the pin ②.
- (4) Set the pin ④ 1.6 mm higher than the pin ②.
- (5) Set the pin ⑤ even with or 0.8 mm higher than the pin ②.
- (6) Tighten the screws ⑥ securely.

Note: Check the tops of the pins are horizontally.

- (1) 抬線架①轉到最低位置。
- (2) 第一片②要跟右邊第四針的線平齊。
- (3) 設定第四片③離第一片②的高度為3.2 mm。
- (4) 設定第三片④離第一片②的高度為1.6 mm。
- (5) 設定第二片⑤離第一片②的高度為0.8 mm。
- (6) 對準後鎖緊螺絲⑥。

註：檢查最上面那片的水平。

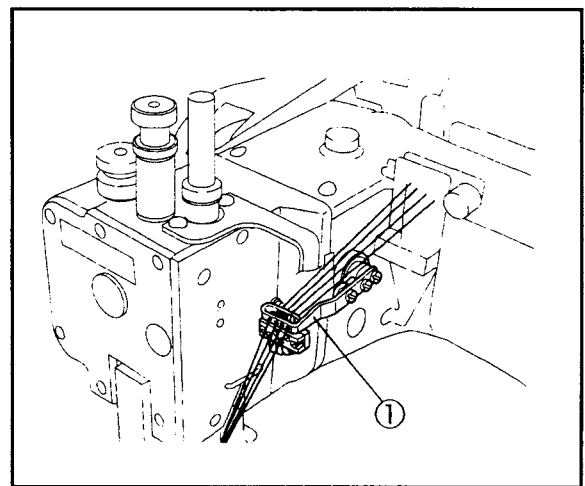

Fig. 45

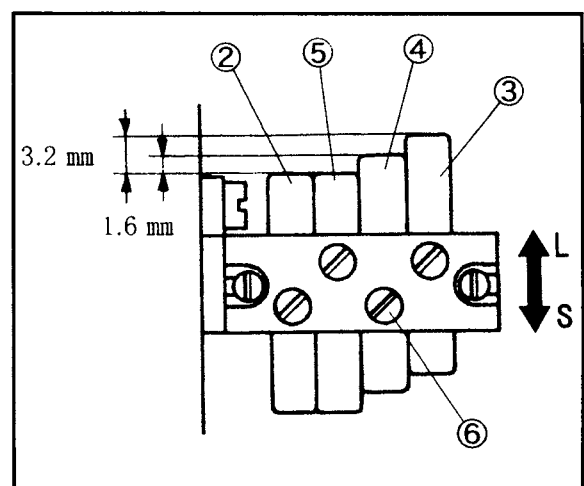

Fig. 46

Loosen the screws⑥and move the pins up or down to adjust the needle thread loop.

- To make the loop larger, move the pins in the direction "L".
- To make the loop smaller, move the pins in the direction "S".

放鬆螺絲⑥調整過線片高低然後調整線圈大小。

- 要把線圈變大就把過線片往上移"L"。
- 要把線圈變小就把過線片往下移"S"。

WARNING

Before adjusting, ALWAYS turn the motor switch OFF and check that the motor has already stopped.

注意

在調整機器之前，一定要先把電源關掉還有確定馬達完全停止。

Needle thread eyelet :

- (1) Make the height of the right needle thread eyelets① to align their eyes with the eyes③ of the needle thread eyelet holder②.
- (2) Set the eyelet④ 5 mm lower than the eyelet①.
- (3) Set the eyelet⑤ 9 mm lower than the eyelet①.
- (4) Set the eyelet⑥ 15 mm lower than the eyelet①.

針線孔：

- (1) 右邊最高的過線孔①要跟線孔③成一直線。
- (2) 設定過線孔④比①低 5 mm。
- (3) 設定過線孔⑤比①低 9 mm。
- (4) 設定過線孔⑥比①低 15 mm。

Loosen the screws⑦ to adjust the needle thread tension.

- To tighten needle thread, move the eyelets in the direction "T".
- To loosen needle thread, move the eyelets in the direction "L".

放鬆螺絲⑦調整線鬆緊。使線變緊移動過線孔向下。

- 過線片往下移，線就會變緊。
- 過線片往上移，線就會變鬆。

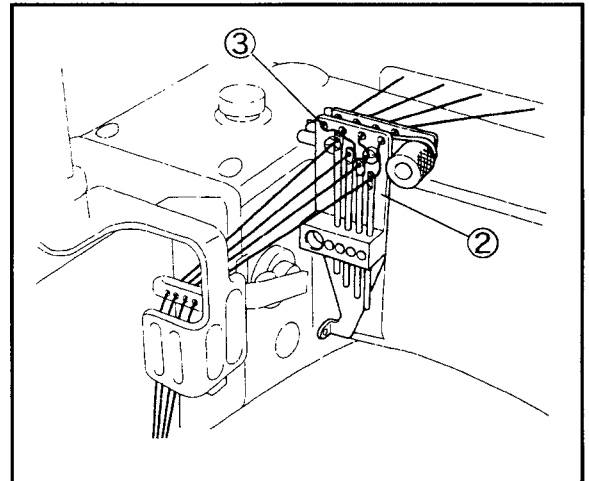

Fig. 47

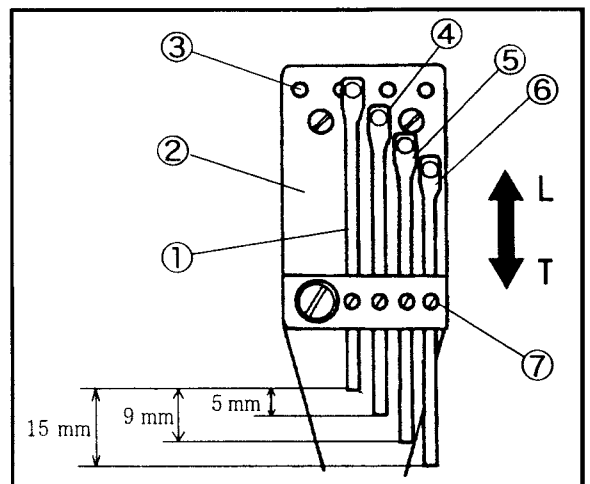

Fig. 48

WARNING

Before adjusting, ALWAYS turn the motor switch OFF and check that the motor has already stopped.

注意

在調整機器之前，一定要先把電源關掉還有確定馬達完全停止。

6.2 Looper thread tension

6.2 下底線

Top looper thread take-up is seen from the front in Fig. 49
調整底線鬆緊請看圖49。

Position of looper thread take-up guide :

Align the right of the looper thread take-up guide①with that of the eyelet supporting plate②.

底線鬆緊位置的指南：

底線導板①和支稱板②要成一線。

Timing of looper thread take-up :

Position the looper thread take-up④as standard so that looper thread passes at the point A when the needle bar③is lowered 2.8 mm from the highest point. Loosen the screws⑤to adjust it.

底線收緊時機：

正確的凸輪④位置是當針柱桿③最高的位置下移 2.8 mm 時線通過 A 點。放鬆螺絲⑤去調整。

- To increase the looper thread take-up amount, hasten the timing.
- To decrease the looper thread take-up amount, delay the timing.
- 增加底線的鬆度，把線凸調快。
- 減少底線的鬆度，把線凸調慢。

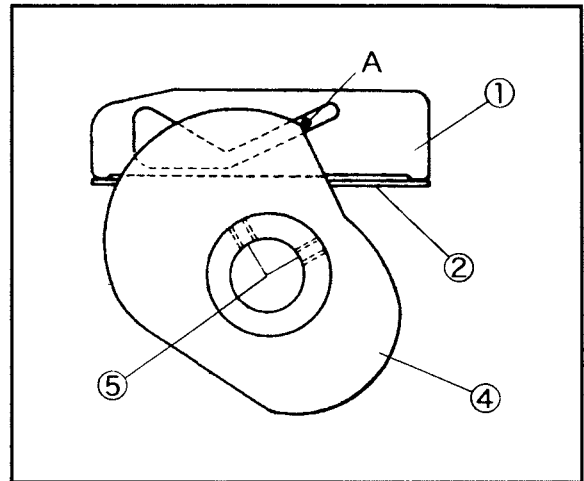

Fig. 49

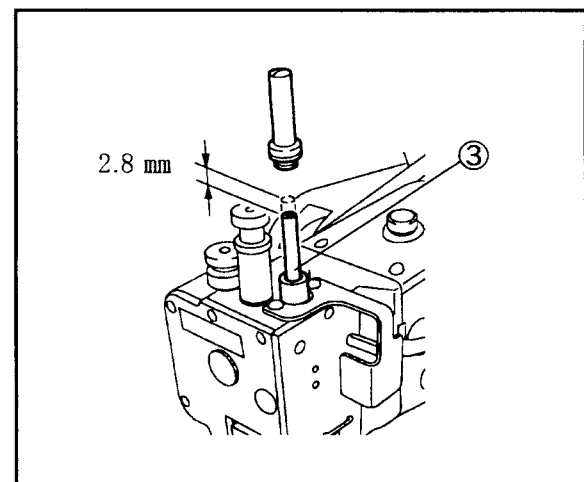

Fig. 50

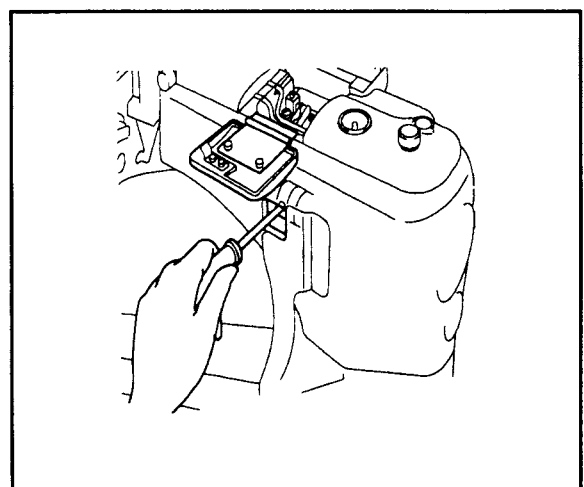

Fig. 51

Note : When adjusting take-up④, face both bosses of the take-up④and the top cover thread take-up without shifting the front-and-rear position.

註：當調整凸輪④時面向凸輪④凸出的地方和上線抬起時不用調整前後位置。

CAUTION

If the timing of the looper thread take-up exceeds the adjustable range, it may occur skip stitch.

注意

如果時間差，調超過會造成跳針。

Position of looper thread take-up eyelet :

Set the looper thread take-up eyelets⑥and⑦at the extreme right as standard.

Loosen the screws⑧and⑨, and move them right or left to adjust it.

下勾針凸輪的位置：

底線過線片在標準最右邊。

放鬆螺絲⑧和⑨左右移動去調整。

- To increase the looper thread take-up amount, move them in the direction "L".
- To decrease the looper thread take-up amount, move them in the direction "S".
- 增加底線的量，將過線片往"L"的方向移動。
- 減少底線的量，將過線片往"S"的方向移動。

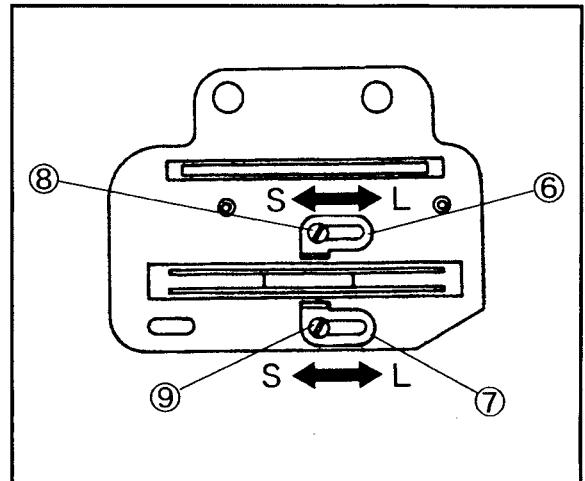

Fig. 52

WARNING

Before adjusting, ALWAYS turn the motor switch OFF and check that the motor has already stopped.

注意

在調整機器之前，一定要先把電源關掉還有確定馬達完全停止。

6.3 Top cover thread tension

6.3 上網線

The top cover thread take-up is seen from the front in Fig. 53

調整上網線的鬆緊請看圖53。

Position of thread take-up eyelet :

Make the standard distance from the top the eyelet supporting plate②to the thread take-up eyelet①eye to 4.4 mm.

Loosen the screw③and move the eyelet①up or down to adjust it.

- To increase the top cover thread take-up amount, move the eyelet①downward.
- To decrease the top cover thread take-up amount, move the eyelet①upward.

線孔位置：

支稱板②和過線片①的標準距離是4.4 mm。

放鬆螺絲③再上下調整移動線孔。

- 增加線量時，將過線片①往下移。
- 減少線量時，將過線片①往上移。

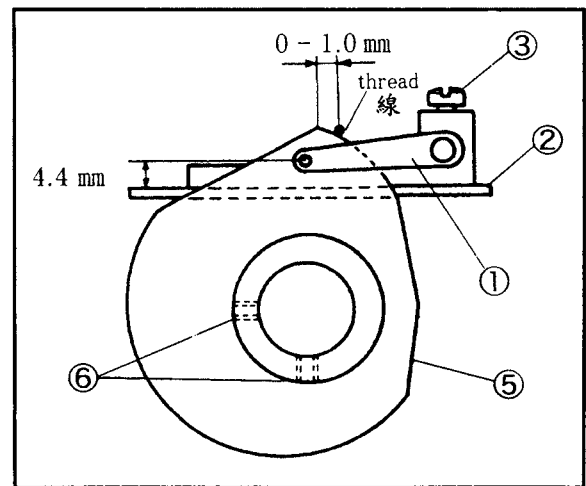

Fig. 53

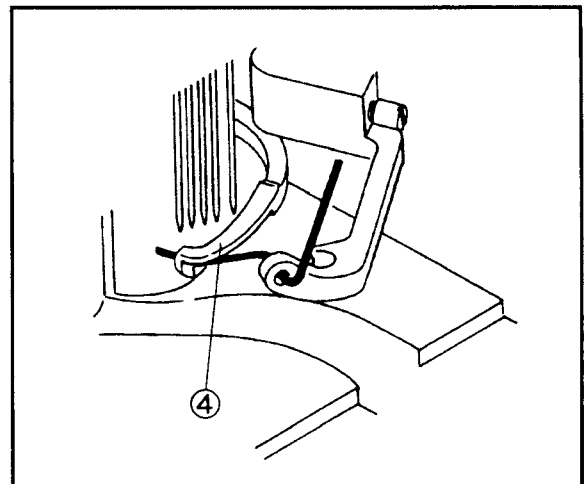

Fig. 54

Timing of top cover thread take-up :

The moment the top cover thread is hooked with the top cover thread hook④ (Fig. 54), the thread is held at the point 0 - 1.0 mm apart from the top of the take-up⑤.

Loosen the screws⑥to adjust it.

調整上網線的時機：

當大的上勾針④勾到小勾針上的線時間(如圖54)網線和凸輪的尖端距離為0 -1.0 mm 之間，調整凸輪⑤時鬆開螺絲⑥。

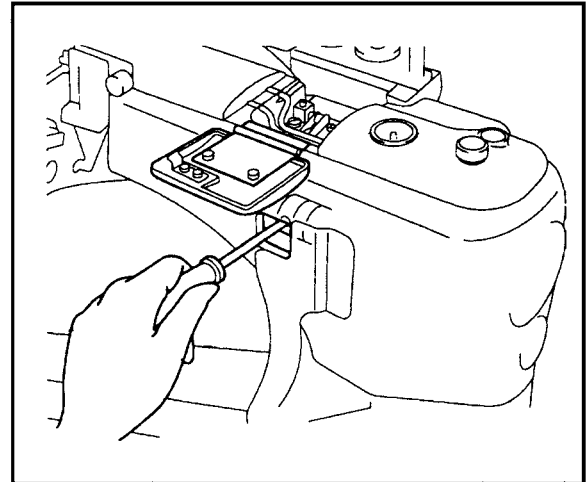

Fig. 55

Note : When adjusting take-up⑤, face both bosses of the take-up⑤and the looper thread take-up without shifting the front-and-rear position.

註：調整好凸輪⑤時，勾線時間和凸輪⑤時間正確後，不必再前後調整。

WARNING

Before adjusting, ALWAYS turn the motor switch OFF and check that the motor has already stopped.

注意

在調整機器之前，一定要先把電源關掉還有確定馬達完全停止。

6.4 Height of needle

6.4 針位高度

Make height "N" of the needle from the top of the stitch plate to the tip of the fourth needle from the left when the needle is at the highest point.

第一支針跟針板的距離為"N"的高度，但針距大小高度就不同如表所示。

Needle distance	Height(N)
R : 5.2 mm	13.49mm
S : 6.0 mm	12.7 mm

Adjusting height :

- (1) Remove the seal plug①.
- (2) Loosen the screw②.
- (3) Move the needle bar③up or down to adjust the height.

Check the alignment in Fig. 58.

- (4) Tighten the screw②securely.
- (5) Reset the seal plug①.

調整高度：

- (1) 移開油塞①。
- (2) 鬆開螺絲②。
- (3) 上下移動針柱③去調整度。

檢查調整如圖58

- (4) 鎖緊螺絲重新裝上油塞螺絲②。
- (5) 裝回油塞①。

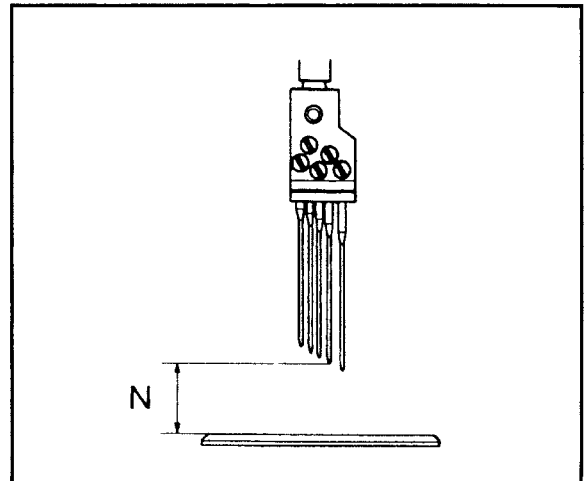

Fig. 56

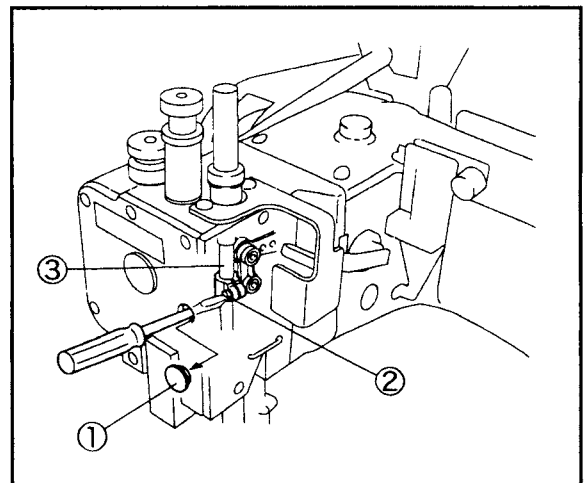

Fig. 57

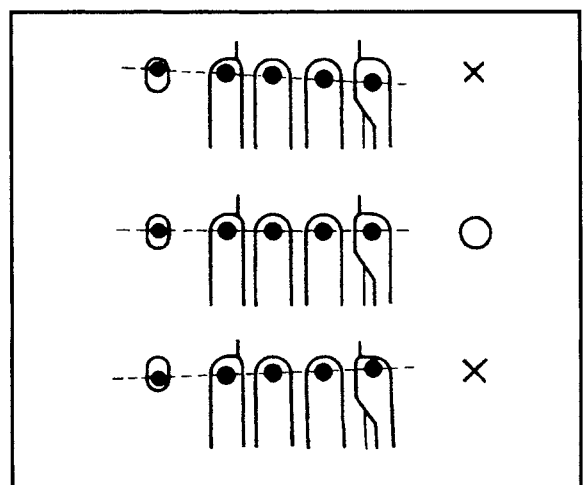

Fig. 58

WARNING

Before adjusting, ALWAYS turn the motor switch OFF and check that the motor has already stopped.

注意

在調整機器之前，一定要先把電源關掉還有確定馬達完全停止。

6.5 Top cover thread carrier and hook

6.5 上勾針

Top cover thread carrier :

Position the top cover thread carrier①so that top cover thread loop formed with the hook behind the first and the second needles from the left when the carrier①comes most nearly to the needle.

Loosen the screw⑤to adjust it.

上網線的時間點：

調整上勾針的位置形成線圈，使第一針和第二針插入線圈內，放鬆螺絲⑤調整上勾針①。

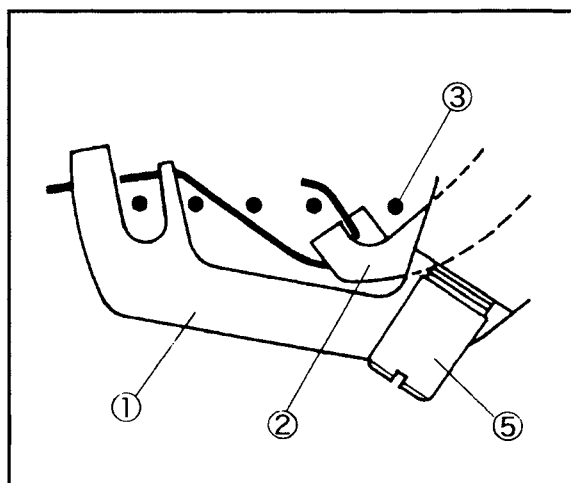

Fig. 59

Top cover thread hook :

When the top cover thread hook②comes most nearly to the top cover thread carrier①, make the clearance between them to 0.4 -0.7 mm during one rotation.

When the hook②moves at the etreme right, make the clearance between the hook②and the retainer③to 0.5 mm .

Loosen the screw⑥to adjust them.

上勾針(大) :

當(大)上勾針②和小上勾針①最接近時的間隙為 0.4 -0.7 mm 。

當(大)上勾針②停在最右邊的時後，和假針③要 0.5 mm 的間隙。

放鬆螺絲⑥去調整。

Note : Be sure adjust them without play up and down.

註：要調整時，不要抬壓腳的上下。

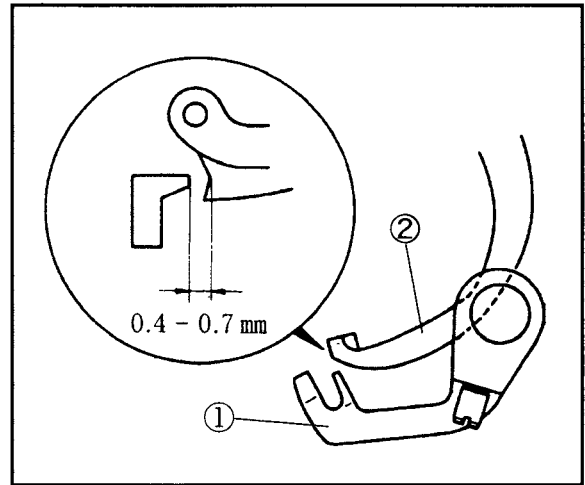

Fig. 60

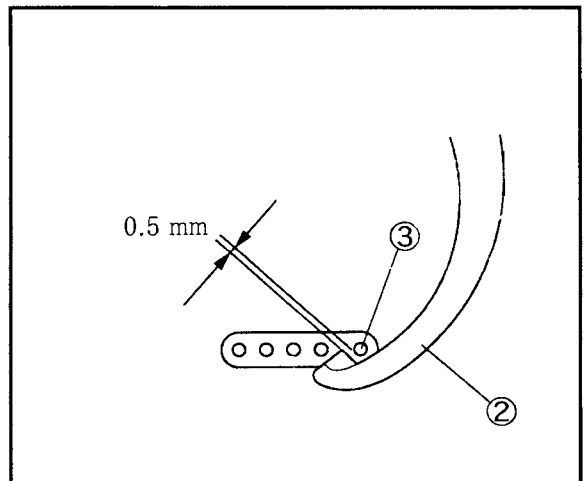

Fig. 61

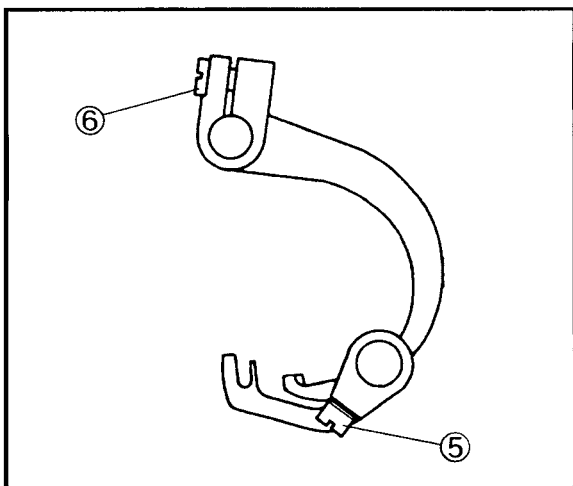

Fig. 62

WARNING

Before adjusting, ALWAYS turn the motor switch OFF and check that the motor has already stopped.

注意

在調整機器之前，一定要先把電源關掉還有確定馬達完全停止。

6.6 Looper

6.6 下勾針

Height :

Insert the looper①into the hole of the looper holder⑥ in most position and tighten the screw②securely.

高度：

裝下勾針①到下勾針座上⑥然後鎖緊螺絲②。

Angle :

Fix the surface A of the looper at 90° to the looper rocker shaft③.

Loosen the screw④to adjust it.

角度：

下勾針固定座平面 A 要和下勾針柱成90度。

放鬆螺絲②去調整下勾針。

Distance between looper and needle :

Make standard distance between the looper tip and the center of the left needle to 4.2 - 4.8 mm when the looper ① is at the extreme left.

Loosen the screw④to adjust it.

下勾針和針的距離：

當下勾針在最左邊的時候，下勾針和針的標準距離 4.2 - 4.8 mm。

放鬆螺絲④去調整。

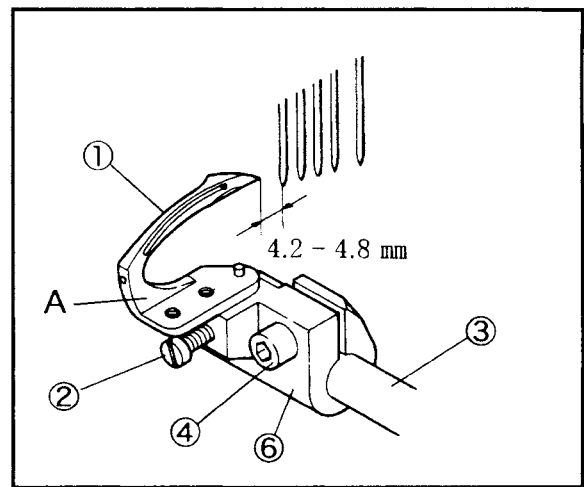

Fig. 63

Front-and-rear position of looper and needle:

When the looper① moves from the left to the right, it passes behind the needle.

Adjust the position so that the looper comes closely to the needle with the clearance of 0 - 0.05 mm but without touching them when the looper tip comes at the center of the left needle.

Loosen the screw④ and turn the adjusting screw⑤ to adjust it.

- To move forward, turn the screw⑤ clockwise.
- To move backward, turn the screw⑤ counterclockwise.

After adjusting, check the distance and tighten the screw④ securely.

下勾針的前後位置：

當下勾針①移動從左到右會在針的後面。調整其位置使下勾針更接近針間隙 0 - 0.05 mm，但不能碰到針，當下勾針的尖端在左針的中間時，放鬆螺絲④轉動螺絲⑤調整前後位置。

- 順時間旋轉螺絲⑤會往前。
 - 逆時間旋轉螺絲⑤會往後。
- 調整之後檢查間隙和鎖緊螺絲④。

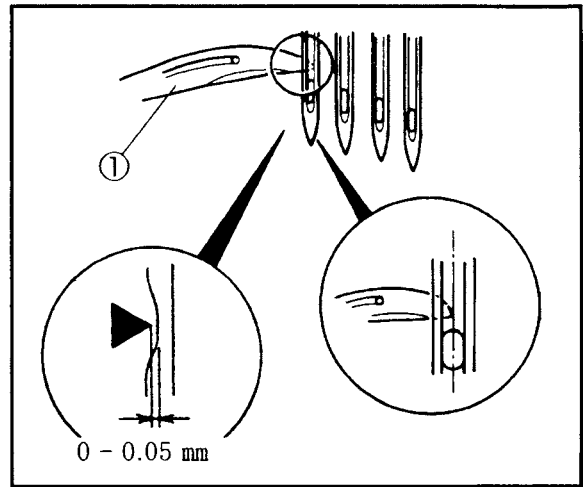

Fig. 64

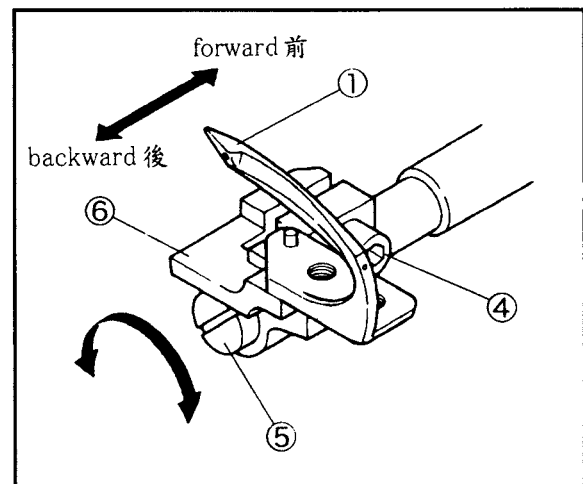

Fig. 65

WARNING

Before adjusting, ALWAYS turn the motor switch OFF and check that the motor has already stopped.

注意

在調整機器之前，一定要先把電源關掉還有確定馬達完全停止。

6.7 Needle guard (front)

6.7 前針檔

Push the needle guard(front)① so that the clearance between the needle and the looper is 0 mm when the looper tip comes at the center of the left needle.

Loosen the screw② to adjust it.

Check the looper tip touches the back of the needle and does not swing to the right when the looper③ moves from the left to the right while rotating the handwheel.

當針在左針中間時推前針檔①，使針和下勾針的間隙為0 mm。放鬆螺絲②去調整它。

當下勾針左移到右時檢查下勾針③有無碰到針的後面，看針有無左右移動。

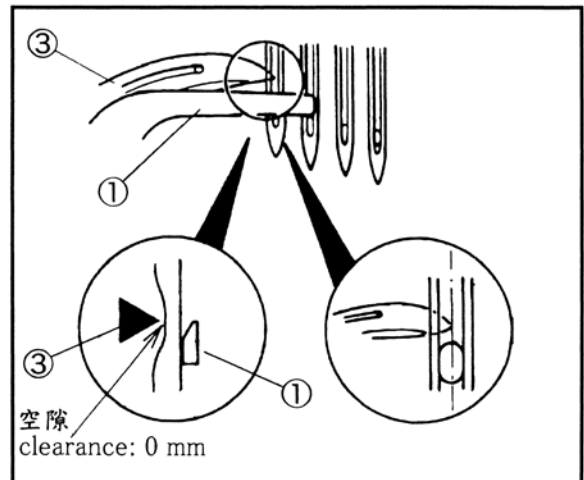

Fig. 66

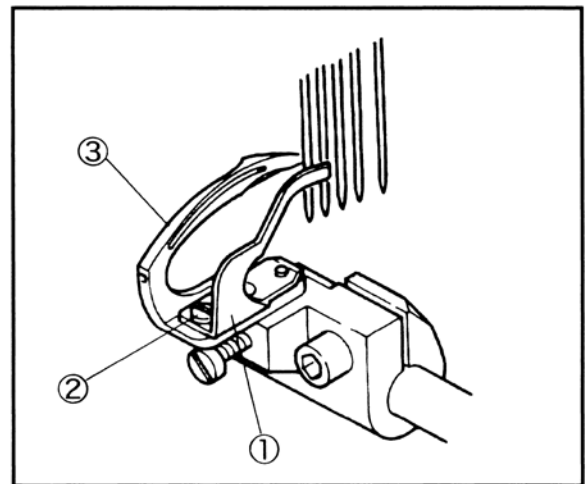

Fig. 67

6.8 Needle guard (rear)

6.8 後針檔

Make the standard clearance between the needle guard (rear)④ and the left needle to 0.05 - 0.1 mm when they meet most closely.

Open the looper cover and loosen the screw⑤ to adjust it.

Check the needle does not swing to the right when the looper moves from the left to the right while rotating the handwheel.

當後針檔④和針最靠近的時候要有0.05-0.1mm的間隙。放鬆螺絲⑤去調整。

當下勾針從左移到右時，後針檔不能碰到針。

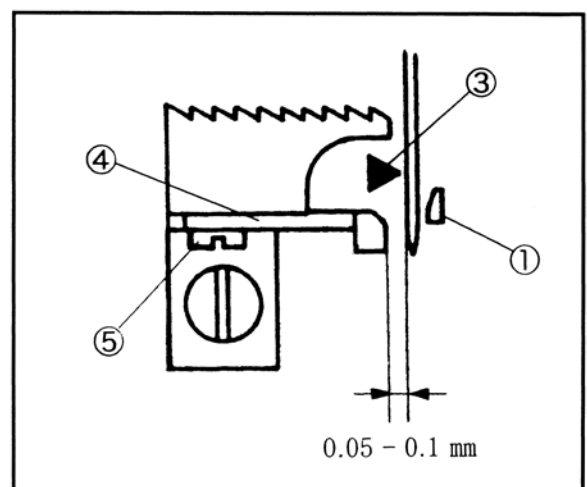

Fig. 68

CAUTION

After changing stitch length, the clearance changes between the needle guard(rear)③set on the main feed dog and the needle.

Readjust the position of the needle guard(rear)③ after changing stitch length.

注意

當有調整針距時，注意後針檔③要重新調整。

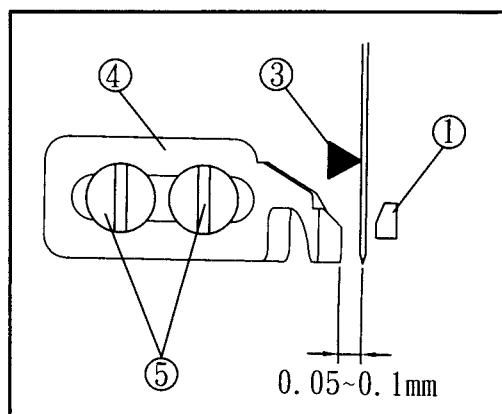

Fig.68GX

WARNING

Before adjusting, ALWAYS turn the motor switch OFF and check that the motor has already stopped. 在調整機器之前，一定要先把電源關掉還有確定馬達完全停止。

注意**6.9 Height of feed dog****6.9 勾齒高度****Fixing :**

Fix the differential feed dog①and main feed dog③with the screws②and④respectively.

Fix the needle guard(rear)⑤on the main feed dog and tighten it at the most rear position with the screw⑥slightly.

Note : See "6.8 Needle guard(rear)" to adjust it.

安裝：

固定差動的勾齒和主要勾齒③用螺絲②和④固定後針檔⑤在主要勾齒上調整時，鬆開螺絲⑥。

註：參考 "6.8 後針檔" 的調整方法。

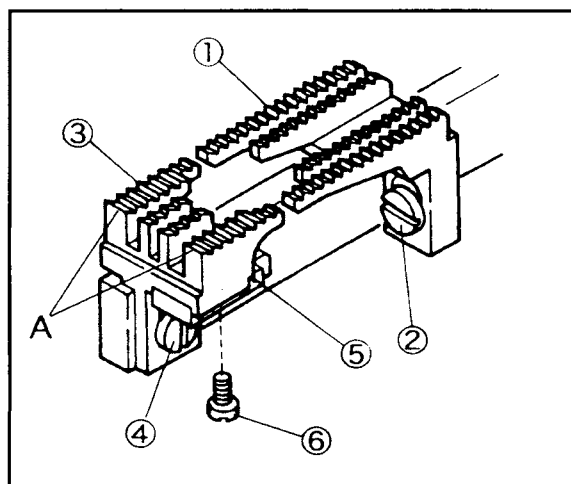

Fig. 69

Height :

Adjust the height from the top of the stitch plate to the part A of the main feed dog③to 1.2-1.5 mm when the feed dog is at the highest point.

Align the differential feed dog even with the main feed dog.

高度：

當勾齒在最高點時，主勾齒③和針板的高度為 1.2-1.5 mm 前後勾齒必須保持一樣的高度。

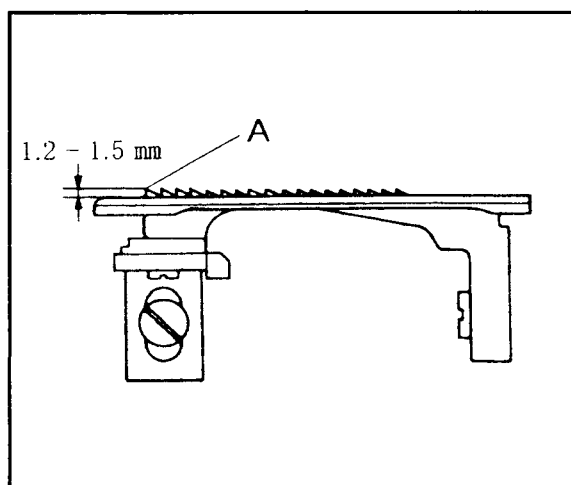

Fig. 70

Fine adjustment of height :

Make fine adjustment of height of the main and differential feed dogs with the feed bar eccentric pin⑧near the center of the cylinder.

Loosen the screw⑦and move the pin⑧to adjust it.

- To lower the feed dog, turn the pin⑧clockwise.
- To raise the feed dog, turn the pin⑧counterclockwise.

高度微調：

勾齒的高度微調要旋轉偏心銷⑧來控制。

放鬆螺絲⑦然後調整偏心銷⑧的高低。

- 順時針旋轉偏心銷⑧降低勾齒。
- 逆時針旋轉偏心銷⑧調高勾齒。

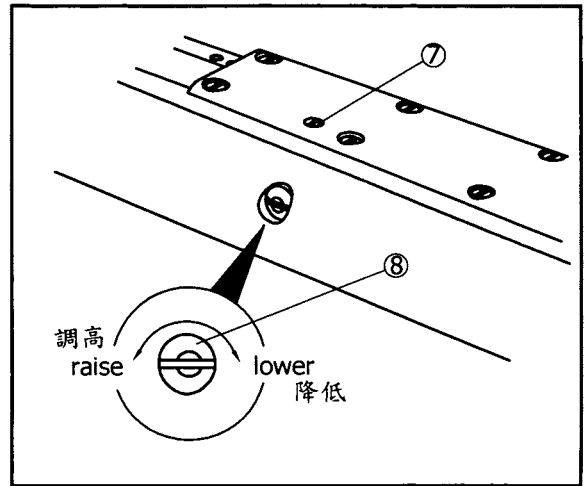

Fig. 71

Advice on adjustment

Set the groove of feed bat eccentric pin⑧horizontally with the screw⑦before fixing the main and differential feed dogs.

This is to adjust the equal movemnt of them.

調整建議：

裝上前後勾齒前先調整偏心銷⑧成水平，鬆開螺絲⑦才能同時移動前後勾齒的高低。

Easy to use

When only removing the stitch plate, turn the feed bar eccentric pin⑧to the left to lower the feed dogs.

簡易方法：

要拆掉針板時，先把偏心銷⑧向左旋轉一點，使勾齒同時調低，好讓針板容易折下。

WARNING**注意**

Before adjusting, ALWAYS turn the motor switch OFF and check that the motor has already stopped. 在調整機器之前，一定要先把電源關掉還有確定馬達完全停止。

6.10 Replacing presser foot**6.10 置換壓腳****Removing :**

- (1) Remove all needles and the seal plug①.
- (2) Loosen the adjusting screw②and then the screw③ of the presser bar connecting bracket.

調動方法：

- (1) 移開所有的針和油塞①。
- (2) 放鬆調整螺帽②然後才鬆開螺絲③。
- (3) Loosen the screw④of the knife holder guide collar to be free the complete set including the upper knife, the knife holder, and the knife holder shank.
(3) 鬆開刀台的螺絲④讓整組刀架鬆開。
- (4) Loosen two screws⑦of the knife holder bracket⑥to remove the knife holder guide collar, c. set⑤and the upper knife.
- (5) Loosen the screw⑧on the back of the presser foot.
(Fig. 74)
- (4) 鬆開刀座連桿⑥的兩顆螺絲⑦去移除上刀座⑤和上刀。
- (5) 放鬆壓腳螺絲⑧。(圖74)

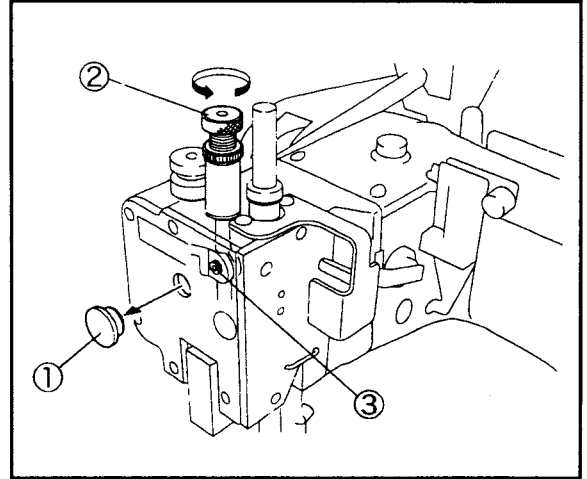

Fig. 72

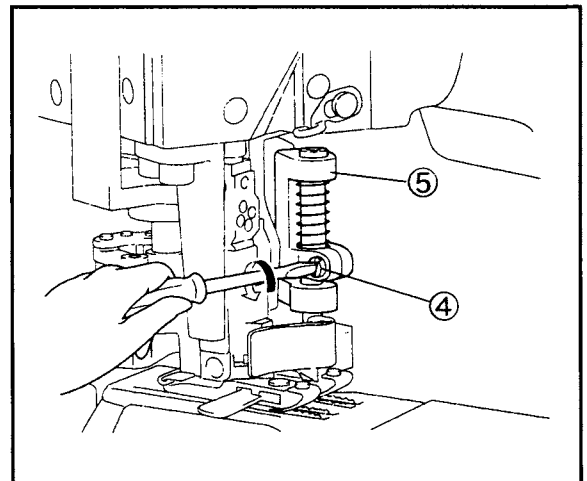

Fig. 73

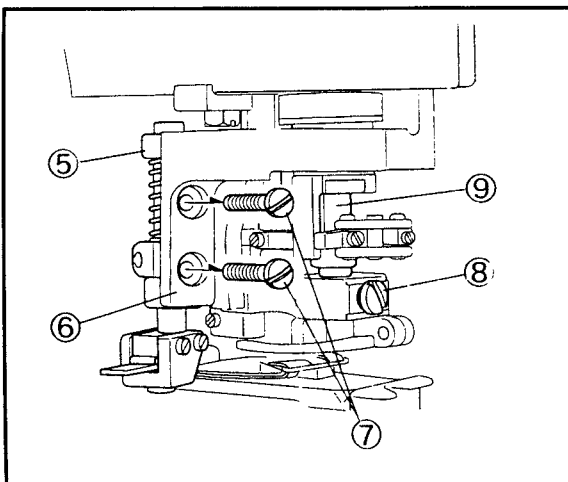

Fig. 74

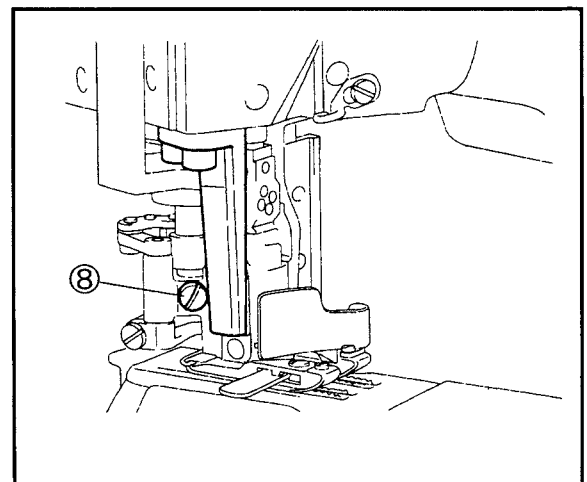

Fig. 75

(6) Rotate the handwheel to raise the needle at the highest point. Remove the adjusting screw②and keep the presser bar⑨and the presser spring⑩upward as they come off from the presser foot.

(6) 將針轉到最高點然後移除調整螺帽②和抽出壓腳柱和壓腳彈簧向上出來。

(7) Remove the carrier/hook driving segment⑪from the lever⑫on the carrier/hook driving sleeve.

(7) 推開上勾針驅動片⑪從帶動桿⑫脫離。

(8) Turn the presser foot, c. set to the left and remove it through the presser foot guides(left) and (right) backward.

(8) 向左轉拆下整組壓腳穿過左邊壓腳檔。

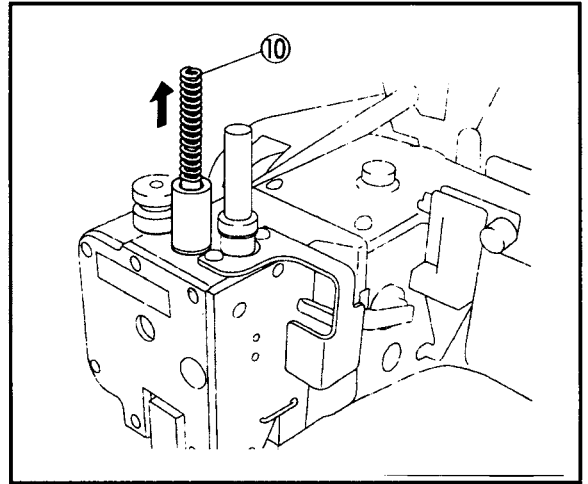

Fig. 76

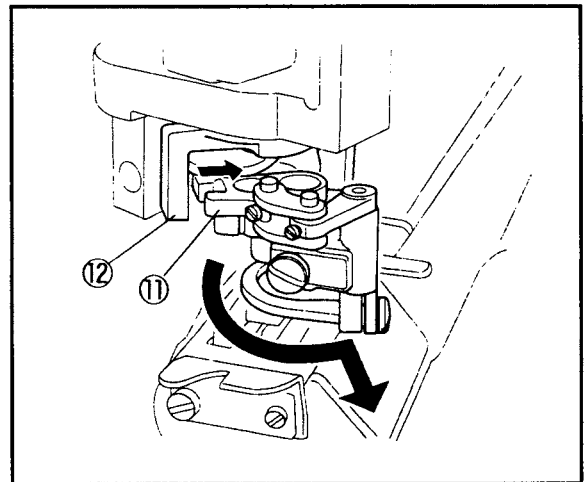

Fig. 77

WARNING**注意**

Before adjusting, ALWAYS turn the motor switch OFF and check that the motor has already stopped. 在調整機器之前，一定要先把電源關掉還有確定馬達完全停止。

Resetting :

Refer to Figs. 72-77 for resetting.

- (1) Remove all needles. Reset the presser foot, c. set between the presser foot guides(left) and (right) while turning it to the right diagonally from the back.

重排：

將圖72-77重新安裝

- (1) 拆掉全部的針重新裝上壓腳在左右壓腳檔之間，向右旋轉，放正壓腳。
- (2) Reset the carrier/hook driving segment⑪on the lever ⑫on the carrier/hook driving sleeve.
- (2) 重新裝上上勾針驅動片⑪到帶動桿⑫裡面。
- (3) Insert the presser bar into the carrier/hook driving segment⑪and tighten the screw on the back of the presser foot.
- (3) 安裝壓腳柱插入上勾針驅動片⑪後鎖上壓腳後面的螺絲。
- (4) Check the presser foot moves smoothly without play right and left. If not, loosen the screw⑭of the presser foot guide(left)⑬to adjust it.
- (4) 檢查壓腳是否順暢沒有左右晃動，如果有卡住，鬆開左壓腳檔⑬的螺絲⑭去調整。
- (5) Reset the knife holder guide collar, c. set⑤and the upper knife on the knife holder bracket⑥with two screws.
- (5) 重新裝上刀台⑤固定在刀座⑥支撐架上。
- (6) Adjust the positions of the knife holder guide collar and the upper knife when the needle is at the lowest point. (See "6.12 Replacing and adjusting knives" .)
- (6) 調整刀台和上刀的位置，當針在最低點的時候。(參考"6.12 置換和調整位置")

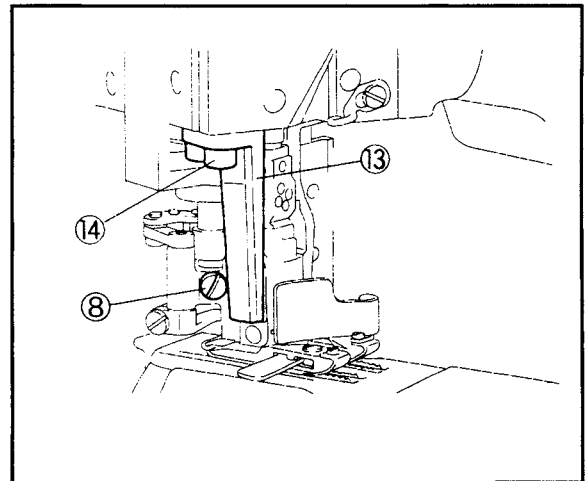

Fig. 78

(7) Reset the adjusting screw②when the needle is at the lowest point and the presser foot touches closely on the stitch plate. Then tighten the screw③of the presser bar connecting bracket while pushing slightly down.

(7) 當壓腳緊貼在針板上和針在最低點時重新裝上調整螺帽②然後輕微的壓下螺絲③並鎖上。

(8) Reset the seal plug①.

(8) 裝回油塞。

(9) Reset all needles.

(9) 裝回所有的針。

WARNING**注意**

Before adjusting, ALWAYS turn the motor switch 在調整機器之前，一定要先把電源關掉還有確定馬
OFF and check that the motor has already stopped. 達完全停止。

6.11 Replacing presser foot spring plate**6.11 置換壓腳彈簧片****Removing :**

- (1) Remove the screws①.
- (2) Remove the presser foot spring plates②from the presser foot.
- (3) Remove each plate②from the spring plate holder③.

調動方法：

- (1) 拆掉螺絲①。
- (2) 拆掉壓腳彈片②。
- (3) 移開彈簧片勾③才能拿掉彈簧片②。

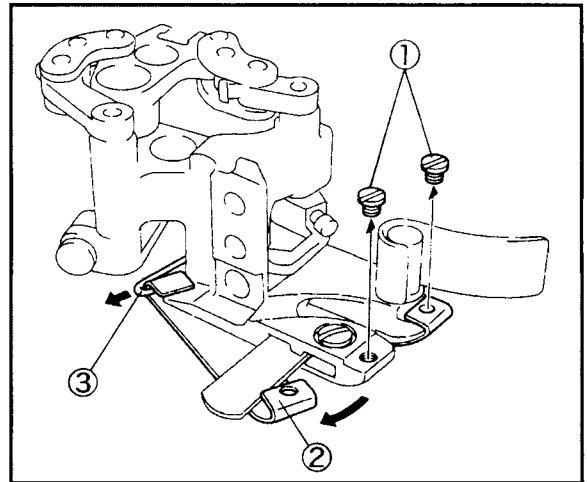

Fig. 79

Resetting :

- (1) Reset each presser foot spring plate②with the spring plate holder③.
- (2) Reset the plates②parallel each other on the presser foot②.
- (3) Tighten the screws①securely.

重排：

- (1) 重新裝上壓腳彈片②和壓腳彈片勾③。
- (2) 每片彈簧片②要對齊壓腳座。
- (3) 鎖上螺絲①。

WARNING**注意**

Before adjusting, ALWAYS turn the motor switch 在調整機器之前，一定要先把電源關掉還有確定馬 OFF and check that the motor has already stopped. 達完全停止。

6.12 Replacing and adjusting knives**6.12 置換和調整位置****Pressure of upper knife :**

When the needle is at the highest point and the upper knife ① is at the extreme left, the presser foot touches the stitch plate, and the upper knife ① touches the lower knife ② closely.

The standard clearance between the bearing of the knife holder shank support ③ and the knife holder guide collar ④ is 1.0 mm .

上切刀的壓力：

當針在最高點，上切刀在左邊時壓腳要貼著針板上，上切刀 ① 刀刀要貼合下切刀 ② 的刀刀。

刀座 ③ 和壓力彈簧軸環 ④ 之間的標準間隙為 1.0mm。

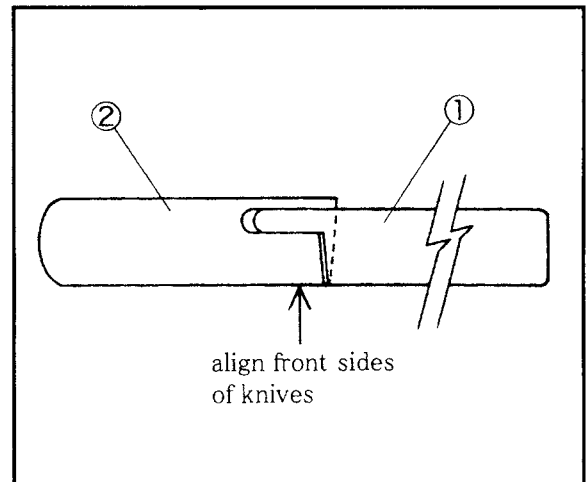

Fig. 80

Loosen the screw ⑤ and move the knife holder guide collar ④ to adjust the pressure.

- To increase the pressure, move the collar ④ upward.
- To decrease the pressure, move the collar ④ downward.

鬆開螺絲 ⑤ 和移動軸環 ④ 調整壓力。

- 增加壓力往上移動彈簧軸環 ④。
- 減少壓力往下移動彈簧軸環 ④。

Note : Align the front sides of the upper ① and lower ② knives without touching the upper knife to the presser foot.

After check them, fix the knife holder guide collar ④ with the screw.

註：上刀 ① 和下刀 ② 成一直線時，上刀不能碰到壓腳壁，正確後固定彈簧軸環 ④。

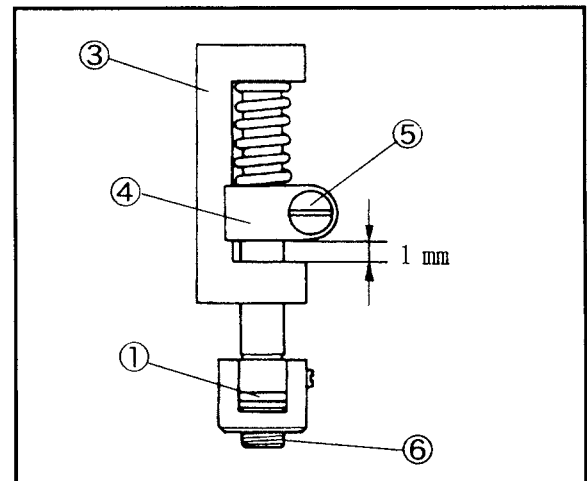

Fig. 81

Removing :

(1) Loosen the screws⑤and⑥to remove the upper knife
①.

(2) Loosen the screw⑦to remove the lower knife②.

調動方法：

(1) 放鬆螺絲⑤和⑥才能拆掉上切刀①。

(2) 放鬆螺絲⑦才能拆掉下切刀②。

Resetting :

(1) Reset the lower knife②with the screw⑦.

(2) Reset the upper knife①with the screw⑥.

See "5.9 Adjusting lapped width of upper fabric" for engagement of the knives.

(3) Adjust the knife holder guide collar④, referring to above "Pressure of upper knife".

重排：

(1) 重新安裝下切刀②要鎖緊螺絲⑦。

(2) 重新安裝上切刀①要鎖緊螺絲⑥。安裝方法請看 "5.9 調整切布刀"。

(3) 調整軸環④請依前面幾項說明的方法來調整。

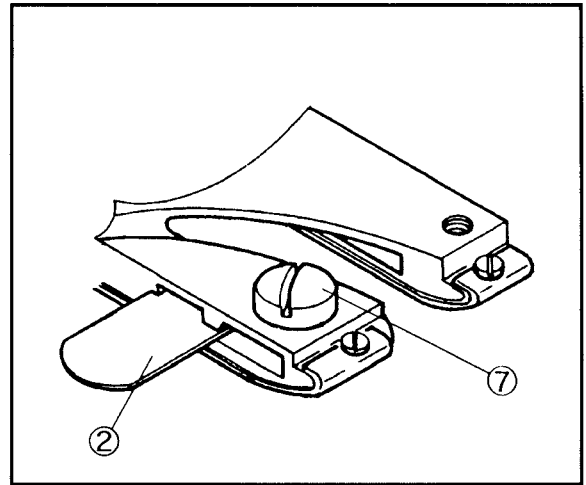

Fig. 82

Engaging angle of upper knife to lower knife

Remove the parts①-⑤in order and turn the screw⑥to adjust it.

When resetting, check the screw⑦is not out from the bottom of the knife support⑤. Then insert it into the bracket hole⑧to tighten.

上切刀角度之調整

拆掉①-⑤的部份，螺絲⑥去調整刀的角度。

重新安裝時要注意插銷⑦有無對準刀座⑧上的孔。

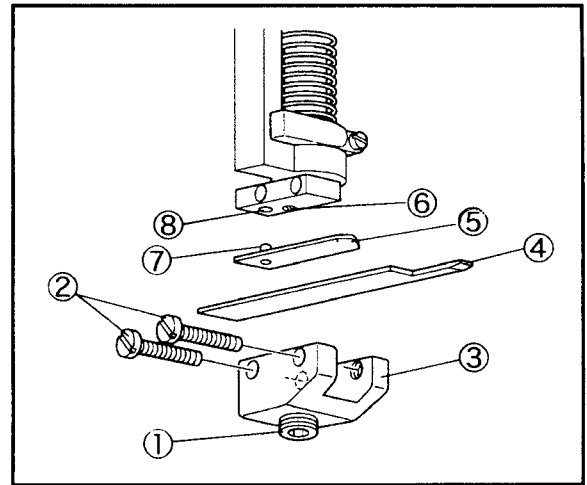

Fig. 83

7. Specifications

規格

Description 說明	Four-needle and six-thread feed-off-the-arm model industrial interlock sewing machine 曲臂型四針六線拼縫機
Dimensions 體積	420mm(L) X 300mm(W) X 410mm(H) 420mm(長) X 300mm(寬) X 410mm(高)
Circumference of Cylinder 圓週	148mm at needle drop 針棒下緣最小圓週148 mm
Working Space 工作空間	Cylindrical shape of 210 mm in front of needle drop 圓週210 mm 是本機的操作範圍
Weight 重量	23kg (machine head only) 23公斤 (頭部)
Sewing Speed 車縫速度	Up to 4200 rpm, 3800 rpm in usual 最高每分鐘4200轉，普通每分3800轉
Stitch Length 縫距	1.6-2.5 mm. The number of stitches 10-16 stitches per inch(25.4 mm) 12-19 stitches per 30 mm. 16-25 mm。 每英吋10-16針(25.4mm)。每30mm 12-19針。
Needle System 針型	Sewing needle : Organ FL X 118GCS, Groz-Beckert UY118GKS Retainer needle : Organ FLG-1, FLF-8 (with scarf) Groz-Beckert 36211, 36211A (with scarf) 針車 : Organ FL X 118GCS, Groz-Beckert UY118GKS 假針 : Organ FLG-1, FLF-8 (with scarf) Groz-Beckert 36211, 36211A (with scarf)
Needle Distance 針距	R : 5.2 mm (13/64 inches) S : 6.0 mm (15/64 inches)
Presser Foot Lift 抬壓腳	01 : Max. 8 mm, 02 : Max. 6 mm at the highest point of needle clamp 01 : 最大。 8 mm, 02 : 最大。 6 mm 最高針位
Feed Regulation 送料方式	By lever 桿槓原理
Differential Ratio 差動比	Max. normal differential : 1.0 : 1.5 Max. reverse differential : 1.0 : 0.7 最大 一般差動比 : 1.0 : 1.5 最大 反差動比 : 1.0 : 0.7
Differential Feed Regulation 差動送料規則	By dial 轉盤
Knives of Fabric Cutting 切布刀	Both upper and lower knives made of special steel 上下刀都用特殊鋼製造的

Lubrication 潤滑	Automatically by gear pump 自動齒輪幫浦
Lubricating Oil 潤滑油	SF OIL No.68
Capacity of Oil Reservoir 油槽容量	Frame : about 100 cc Cylinder : about 100 cc 框：約100 cc 筒：約100 cc
Compliance with Regulation 符合規定	Compliant with the PL Law and the CE Marking 符合 PL 法律與 CE 標誌

名匠縫紉機股份有限公司

經銷商：

2012.08